

# BAD BOY

---

## BANDIT

# 550cc - 750cc SERVICE MANUAL



## FOREWORD

---

### **Brief introduction to maintenance handbook of 550UTV/750UTV**



The handbook is edited by Technical Center of Chongqing Huansong Science And Technology Industrial Co.,Ltd, and is supplied to dealers and technicians as document of technique. Mainly, the handbook gives methods to check, maintain and repair utility terrain vehicles (UTV) , and supplies some relevant technique and performance data. Some techniques and method inside may be used to check, maintain and repair other models of UTV, although it is mainly for 550UTV/750UTV.

Please read the handbook through and fully understand it; otherwise, any improper repairing and amounting would bring you problems, and accident may occur in your use.

Proper use and maintenance can guarantee UTV being driven safely, reduce its malfunction, and help the vehicle remain its best performance.

The standards, performances and specifications mentioned in interpretation are based on the sample in design, and they are subject to changes according to the product's improvement without prior notice.

First version ,November, 2014

Published by Chongqing Huansong Science And Technology Industrial Co.,Ltd

Chongqing Huansong Science And Technology Industrial Co.,Ltd holds the copy right.

No publishing and reprinting without permission.

# CONTENT

## CHAPTER 1 GENERAL INFORMATION

<b>GENERAL INFORMATION</b> .....	1
<b>WARNINGS, CAUTIONS AND NOTES</b> .....	1
<b>DESCRIPTION</b> .....	2
<b>IDENTIFICATION CODE</b> .....	4
Frame No. ....	4
Engine No. ....	4
<b>SAFETY</b> .....	5
Handling gasoline safely.....	5
Cleaning parts.....	6
Warning labels.....	6
<b>SERIAL NUMBERS</b> .....	7
<b>FASTENERS</b> .....	7
Torque specifications .....	7
Self-locking fasteners.....	7
Washers.....	7
Cotter pins.....	8
Snap rings and E-clips .....	8
<b>SHOP SUPPLIES</b> .....	9
Lubricants and Fluids.....	9
Engine oils.....	9
Greases.....	9
Brake fluid.....	10
Coolant.....	10
Cleaners, Degreasers and solvents .....	10
Gasket sealant.....	10
Gasket remover .....	11
Thread locking compound.....	11
<b>BASIC TOOLS</b> .....	11
Screwdrivers.....	12
Wrenches .....	12

Adjustable wrenches .....	13
Socket wrenches, ratchets and handles .....	13
Impact drivers .....	14
Allen wrenches.....	14
Torque wrenches.....	14
Torque adapters .....	15
Pliers.....	16
Snap ring pliers.....	16
Hammers .....	17
Ignition grounding tool.....	17
<b>PRECISION MEASURING TOOLS .....</b>	<b>17</b>
Feeler gauge .....	17
Calipers.....	18
Micrometers.....	19
Adjustment .....	19
Care .....	20
Metric micrometer.....	20
Standard inch micrometer.....	21
Telescoping and small bore gauges.....	22
Dial Indicator.....	22
Compression gauge.....	23
Multimeter.....	23
Cltp-on ammeter.....	23
Magneto puller.....	24
<b>ELECTRICAL SYSTEM FUNDAMENTALS.....</b>	<b>24</b>
Voltage .....	24
Resistance.....	24
Amperage.....	24
<b>BASIC SERVICE METHODS.....</b>	<b>25</b>
Removing frozen fasteners.....	26
Removing broken fasteners .....	26
Repairing damaged threads .....	27
Stud Removal/Installation .....	27
Removing hoses .....	27

Bearings.....	28
Removal.....	28
Installation.....	29
Interference fit .....	29
Seal replacement.....	31
<b>STORAGE</b> .....	31
Storage area selection.....	31
Preparing the motorcycle for storage .....	31
Returning the UTV to service.....	32
<b>TROUBLESHOOTING</b> .....	32
<b>ENGINE PRINCIPLES AND OPERATING REQUIREMENTS</b> .....	33
<b>STARTING THE ENGINE</b> .....	33
Engine is cold .....	34
Engine is warm.....	34
Flooded engine.....	34
<b>ENGINE WILL NOT START</b> .....	35
Identifying the problem .....	35
Spark test.....	36
The starter cannot work repeatedly or can only work slowly.....	37
<b>POOR ENGINE PERFORMANCE</b> .....	37
The engine starts slowly or difficultly.....	37
Engine backfires, cuts out or misfires during acceleration.....	37
The engine is not idling or cannot idle stably.....	38
Poor fuel mileage.....	38
Engine will not idle or idles roughly .....	38
Low engine power .....	38
Poor idle or low speed performance.....	40
Poor high speed performance .....	40
<b>FUEL SYSTEM</b> .....	40
Rich mixture.....	41
Lean mixture.....	41
<b>ENGINE</b> .....	41
Engine smoke.....	41
Black smoke .....	41

Blue smoke.....	41
White smoke or steam.....	42
Low engine compression .....	42
High engine compression .....	42
Engine overheating (cooling system) .....	42
Engine overheating (engine).....	43
The ignition advance angle is too large.....	43
Detonation.....	43
Power loss .....	43
engine noises.....	44
<b>ENGLNE LUBRICATION.....</b>	<b>45</b>
<b>HIGH OIL CONSUMPTION OR EXCESSIVE.....</b>	<b>45</b>
Exhaust smoke.....	45
Low oil pressure .....	45
High oil pressure .....	45
No oil pressure.....	45
Oil level too low.....	45
Oil contamination.....	46
<b>CYLINDER LEAK DOWN TEST.....</b>	<b>46</b>
<b>ELECTRICAL TESTING.....</b>	<b>48</b>
Preliminary checks and precautions .....	48
Intermittent problems.....	49
Electrical component replacement .....	50
Test equipment .....	50
Ammeter .....	50
Self-powered test light .....	50
Ohmmeter .....	50
Jumper wire.....	51
<b>TEST PROCEDURES.....</b>	<b>52</b>
Voltage test.....	52
Voltage drop test.....	52
Peak voltage test.....	53
Continuity test.....	53
Testing for a short with a self-powered test light or ohmmeter.....	53

Testing for a short with a test light or voltmeter.....	54
<b>BRAKE SYSTEM.....</b>	<b>54</b>
Soft or spongy brake lever or pedal.....	54
Brake drag.....	55
Hard brake lever or pedal operation.....	56
Brake Grabs.....	56
Brake squeal or chatter .....	56
Leaking brake caliper .....	56
Leaking master cylinder.....	56

## **CHAPTER 2 SPECIFICATIONS**

<b>HOW TO CONVERSION TABLE OF UNIT.....</b>	<b>58</b>
How to use conversion table.....	58
Definition of unit .....	58
<b>GEBERAR SPECIFICATIONS .....</b>	<b>59</b>
<b>ENGINE SPECIFICATIONS .....</b>	<b>62</b>
<b>CHASSIS SPECIFICATIONS.....</b>	<b>68</b>
<b>ELECTRICAL SPECIFICATIONS.....</b>	<b>70</b>
<b>LUBRICATION PIONTS AND LUBRICANT TYPES.....</b>	<b>72</b>
Engine.....	72
Chassis.....	73
<b>HYDROGRAPHIC CHART.....</b>	<b>74</b>
<b>LUBRICATION OIL WAY.....</b>	<b>75</b>

## **CHAPTER 3 MAINTENCE AND ADJUSTMENT OF THE UTV**

<b>MAINTENANCE SCHEDULE.....</b>	<b>76</b>
<b>ENGINE</b>	
Adjusting the valve clearance.....	78
Idle adjustment .....	80
Adjusting the throttle cable.....	81

Checking the spark plug.....	82
Checking the ignition timing.....	83
Measuring the compression pressure.....	84
Changing the engine oil.....	86

## **CHASSIS**

Cleaning the air filter.....	89
Checking the coolant level .....	90
Changing the coolant.....	91
Checking the coolant temperature warning light .....	94
Checking the v-belt.....	95
Cleaning the spark arrester .....	96
Adjusting the brake pedal.....	97
Checking the brake fluid level .....	98
Checking the front brake pads.....	99
Checking the rear brake pads.....	99
Checking the brake hoses and brake pipes .....	100
Bleeding the hydraulic brake system .....	100
Adjusting the select lever shift rod .....	101
Checking the final gear oil level.....	103
Changing the final gear oil.....	103
Checking the differential gear oil.....	104
Checking the constant velocity joint dust boots.....	105
Checking the steering system.....	106
Adjusting the toe-in .....	107
Adjusting the front and rear shock absorbers.....	108
Checking the tires .....	110
Checking the wheels.....	111
Checking and lubricating the cables .....	112

## **ELECTRICAL**

Checking and charging the battery.....	113
Checking the fuses .....	119
Adjusting the headlight beam.....	121
Changing the headlight bulb.....	121
Changing the tail/brake light bulb .....	122



## **CHAPTER 4 ENGINE**

<b>ENGINE NOTE</b> .....	123
<b>ENGINE REMOVAL</b> .....	124
<b>CYLINDER HEAD AND CYLINDER HEAD COVER</b> .....	127
<b>ROCKER ARMS VALES AND CAMSHAFT</b> .....	130
<b>VALVES AND VALVE SPRINGS</b> .....	134
<b>CYLINDER AND PISTON</b> .....	139
<b>ENGINE LEFT CRANKCASE COVER AND A.C. MAGNETO</b> .....	143
<b>BALANCER GEARS AND OIL PUMP GEARS</b> .....	148
<b>PRIMARY AND SECONDARY SHEAVES</b> .....	151
Primary and secondary sheaves.....	151
Primary sheaves.....	152
Secondary sheaves.....	153
<b>CLUTCH</b> .....	158
<b>CRANKCASE</b> .....	162
Starter motor and oil filter.....	162
Crankcase.....	164
Crankcase bearings.....	167
<b>CRANKCASE AND OIL PUMP</b> .....	171
Crankcase and oil pump.....	171
Oil pump.....	172
<b>TRANSMISSION</b> .....	175
Transmission.....	175
Drive axle assembly.....	176
<b>MIDDLE GEAR</b> .....	180
Middle drive shaft.....	181

## **CHAPTER 5 CHASSIS**

<b>MALFUNCTION INSPECTION</b> .....	187
-------------------------------------	-----

## **PANEL AND CARGO BED**

Front panel.....	190
Side cover.....	193
Cargo bed 1.....	196
Cargo bed 2.....	199
Head shed frame.....	202

## **DIRECTION SYSTEM**

Steering wheel part.....	206
Steering mechanism part.....	209

## **BRAKE SYSTEM.....**

Disk brake components.....	215
----------------------------	-----

## **FOOTREST PART .....**

235

## **WHEEL AND TYRE PARTS .....**

239

Front wheels.....	239
-------------------	-----

Rear wheels.....	240
------------------	-----

## **TRANSMISSION SYSTEM.....**

244

C.V axle, front axle.....	244
---------------------------	-----

Front bridge.....	245
-------------------	-----

C.V axle, rear axle.....	253
--------------------------	-----

Rear bridge reducer.....	254
--------------------------	-----

## **SHIFT OPERATING SYSTEM .....**

259

## **SUSPENSION.....**

266

Front swing arm.....	266
----------------------	-----

Front suspension.....	267
-----------------------	-----

Rear suspension.....	272
----------------------	-----

## **COOLING SYSTEM.....**

278

Water and oil radiator.....	278
-----------------------------	-----

## **SEAT .....**

285

## **FUEL TANK.....**

291

## **CHAPTER 6**

### **ELECTRICAL COMPONENTS**

## **ELECTRICAL SYSTEM MALFUNCTION INSPECTION .....**

294

## **ELECTRICAL.....**

295

<b>ELECTRICAL COMPONENTS</b> .....	295
Checking the switch.....	299
Checking the switch continuity.....	300
Checking the bulbs and bulb sockets .....	302
<b>IGNITION SYSTEM</b> .....	302
Circuit diagram.....	302
Troubleshooting.....	303
<b>ELECTRIC STARTING SYSTEM</b> .....	306
Circuit diagram.....	306
Troubleshooting.....	307
<b>STARTER MOTOR</b> .....	310
<b>CHARGING SYSTEM</b> .....	311
Circuit diagram.....	311
Troubleshooting.....	312
<b>LIGHTING SYSTEM</b> .....	313
Circuit diagram.....	313
Troubleshooting.....	314
Checking the lighting system.....	315
<b>SIGNALING SYSTEM</b> .....	316
Circuit diagram.....	316
Troubleshooting.....	317
Checking the signal system.....	318
<b>COOLING SYSTEM</b> .....	324
Circuit diagram.....	324
Troubleshooting.....	325
<b>2WD/4WDSELECTINGSYSTEM</b> .....	327
Circuit diagram.....	327
Troubleshooting.....	328

## **CHAPTER 7**

### **ENGINE MANAGEMENT SYSTEM**

#### **INTRODUCTION**

Ems (engine management system) .....	330
--------------------------------------	-----

Typical components of EMS.....	331
Layout of EMS components.....	332
<b>COMPONENTS OF EMS</b>	
Electronic control unit .....	332
Multec 3.5 injectors .....	333
Throttle body assembly(with stepper motor) .....	337
Engine coolant temperature sensor .....	339
Intake air pressure and temperature sensor .....	339
Oxygen sensor .....	340
Ignition coil.....	340
Fuel pump module.....	344
<b>EMS FAULT DIAGNOSIS</b>	
EME fault diagnosis .....	350
Fault code list.....	350

## CHAPTER 8 TROUBLESHOOTING

<b>STARTING FAILURE/HARD STARTING.....</b>	<b>352</b>
Fuel system .....	352
Electrical system .....	352
Compression system .....	353
<b>POOR IDLE SPEED PERFORMANCE .....</b>	<b>353</b>
Poor idle speed performance.....	353
<b>POOR MEDIUM AND HIGH-SPEED PERFORMANCE .....</b>	<b>354</b>
Poor medium and high-speed performance.....	354
<b>FAULTY GEAR SHIFTING.....</b>	<b>354</b>
Shift lever does not move .....	354
Jumps out of gear.....	354
<b>ENGINING OVERHEATING.....</b>	<b>355</b>
Overheating.....	355
<b>FAULTY BRAKE.....</b>	<b>355</b>
Poor braking effect.....	355
<b>SHOCK ABSORBER MALFUNCTION.....</b>	<b>356</b>

Loss of damping function.....	356
<b>UNSTABLE HANDLING</b> .....	356
Unstable handling.....	356
<b>LIGHTING SYSTEM</b> .....	356
Head light is out of work.....	356
Bulb burnt out.....	357
Error display of meter.....	357

## CHAPTER 9

### 750UTV SERVICE MANUAL

<b>750UTV SPECIFICATIONS</b> .....	359
General specifications.....	359
<b>MAINTENANCE AND ADJUSTMENT OF THE 750UTV ENGINE</b> .....	360
Adjusting the valve clearance.....	360
Idle adjustment .....	362
Adjusting the throttle.....	363
Checking the spark plug.....	364
Checking the ignition timing.....	365
Measuring the compression pressure.....	366
Changing the engine oil level.....	367
Changing the engine oil.....	368
<b>750UTV ENGINE</b>	
<b>ENGINE NOTE</b> .....	371
<b>ENGINE REMOVAL</b> .....	372
<b>CYLINDERHEAD</b> .....	375
<b>VALVE SWING ARM COMP&amp;VALVE</b> .....	381
<b>VALVES AND VALVE SPRINGS</b> .....	388
<b>CYLINDER AND PISTON</b> .....	394
<b>ENGINE COOLING FAN AND A.C. MAGNETO</b> .....	398
<b>BALANCER GEARS AND OIL PUMP GEARS</b> .....	403
<b>PRIMARY AND SECONDARY SHEAVES</b> .....	406
<b>PRIMARY SHEAVE</b> .....	407
<b>SECONDARY SHEAVE</b> .....	408

<b>CLUTCH</b> .....	413
<b>CLUTCH HOUSING</b> .....	414
<b>CRANKCASE STARTER MOTOR AND OIL FILTER</b> .....	418
<b>CRANKCASE</b> .....	419
Crankcase bearings.....	422
<b>CRANKCASE AND OIL PUMP</b> .....	426
Oil pump.....	427
<b>TRANSMISSION</b> .....	430
Drive axle assembly.....	431
<b>MIDDLE GEAR</b> .....	435
Middle drive shaft.....	436

## **CHAPTER 10 WIRING DIAGRAM**

<b>750UTV/550UTV WIRING DIAGRAM</b> .....	442
---	-----

## GENERAL INFORMATION

---

### GENERAL INFORMATION

The text provides complete information on maintenance, tune-up repair and overhaul, Hundreds of photographs and illustrations created during the complete disassembly of four wheel utility terrain venires (UTV) guide the reader through every job, All procedures are in step-by-step format and designed for the reader who may be working on the UTV for the first time.

### WARNINGS, CAUTIONS AND NOTES

The terms **WARNING**, **CAUTION** and **NOTE** have specific meaning in this manual.

**WARNING:** *emphasizes areas where injury or even death could result from negligence.*

*Mechanical damage may also occur. WARNINGS are to be taken seriously*

**CAUTION:** emphasizes areas where equipment damage could result. Disregarding a **CAUTION** could cause permanent mechanical damage. though injury is unlikely.

**NOTE:** provides additional information to make a step or procedure easier or clearer. Disregarding a **NOTE** could cause inconvenience. but would not cause equipment damage or injury.

# GENERAL INFORMATION

## DESCRIPTION

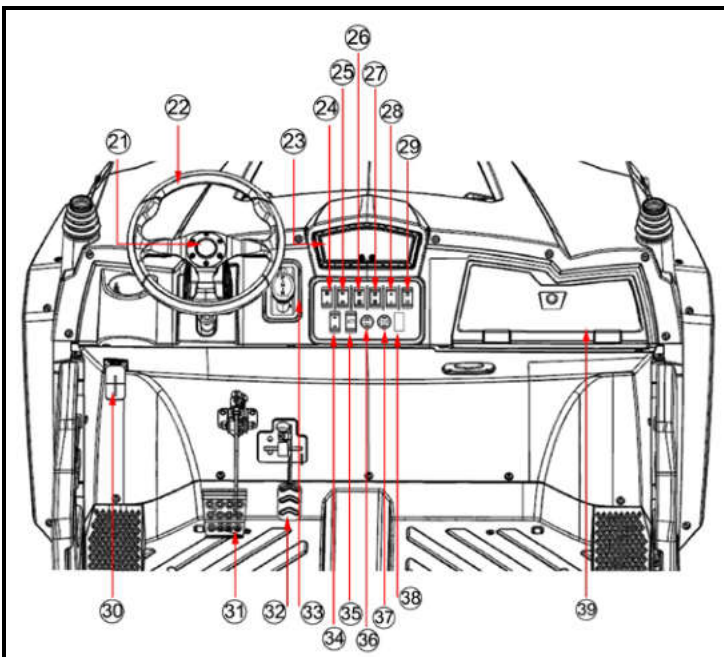
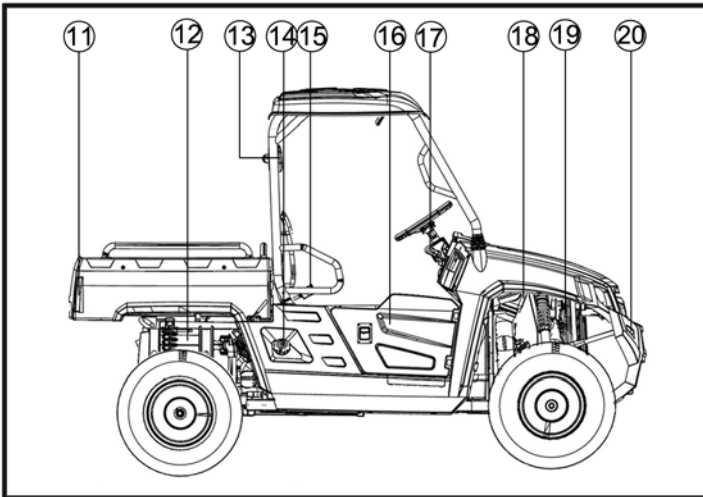
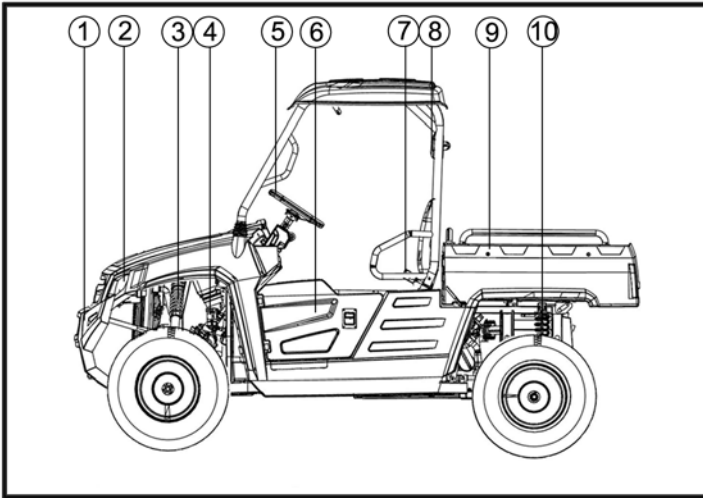

1. Front bumper assy.
2. Headlights
3. Front shock absorber
4. Brake pump
5. Steering wheel
6. Left door comp.
7. Driver seat belt
8. Driver seat headrest
9. Cargo bed
10. Rear shock absorber
11. Tail lights
12. Muffler
13. Passenger seat headrest
14. Fuel tank cap
15. Passenger seat belt
16. Right door comp.
17. Drive select lever
18. Air filter case (engine and air intake duct)Rear brake fluid reservoir
19. Water cooler
20. Front turning lights
21. Horn
22. Steering wheel
23. Gauges
24. Light switch
25. High/low beam lights
26. 2/4 WD
27. Front locking differential
28. Emergency light
29. Winch control
30. Parking
31. Brake pedal
32. Accelerator pedal
33. Gear shift
34. Left/right turning switch
35. Reserved switch
36. DC socket
37. USB
38. Plug cover
39. Glovo box

**NOTE:** \_\_\_\_\_  
 The vehicle you have purchased may differ slightly from those in the figures of this manual.



# GENERAL INFORMATION

## DESCRIPTION

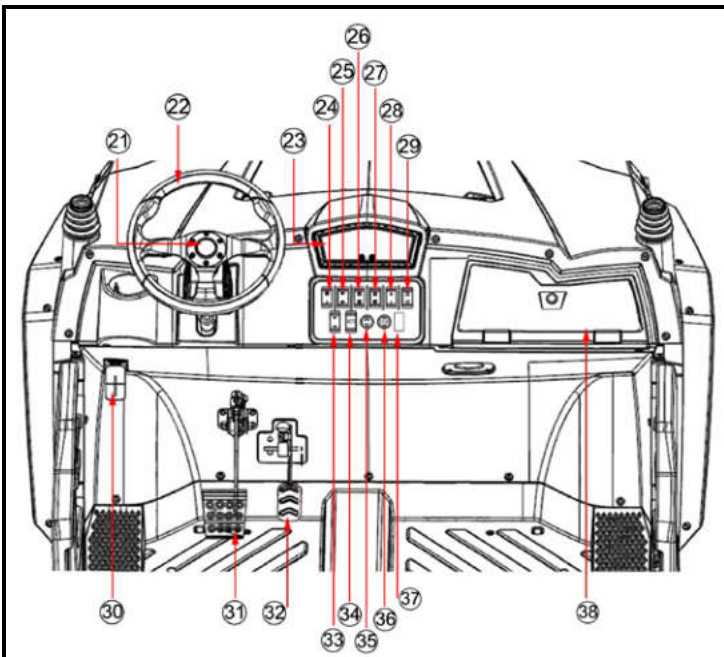
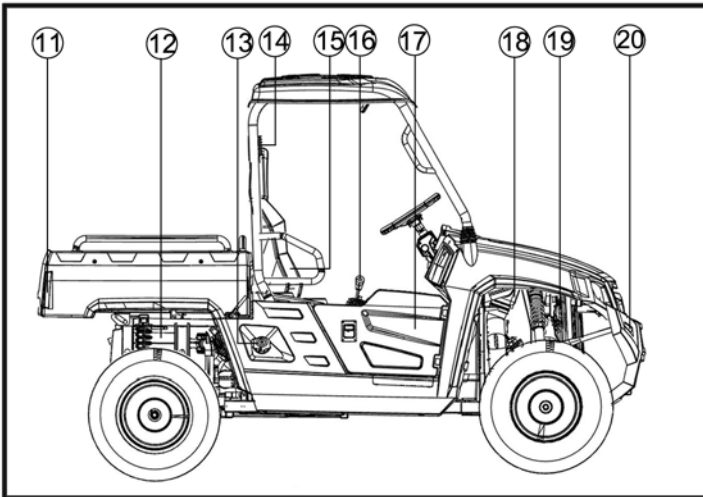
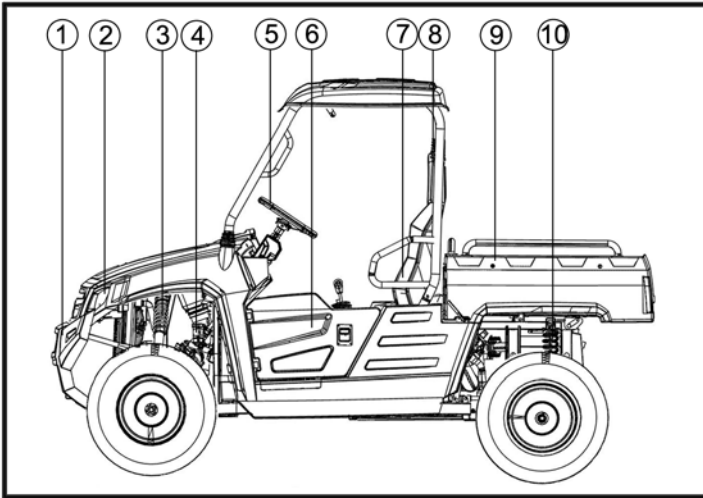

1. Front bumper assy.
2. Headlights
3. Front shock absorber
4. Brake pump
5. Steering wheel
6. Left door comp.
7. Driver seat
8. Driver seat belt
9. Cargo bed
10. Rear shock absorber
11. Tail lights
12. Muffler
13. Fuel tank cap
14. Passenger seat belt
15. Passenger seat
16. Drive select lever
17. Right door comp.
18. Air filter case (engine and air intake duct)/Rear brake fluid reservoir
19. Water cooler
20. Front turning lights
21. Horn
22. Steering wheel
23. Gauges
24. Light switch
25. High/low beam lights
26. 2/4 WD
27. Front locking differential
28. Emergency light
29. Winch control
30. Parking
31. Brake pedal
32. Accelerator pedal
33. Left/right turning switch
34. Reserved switch
35. DC socket
36. USB
37. Plug cover
38. Glovo box

**NOTE:** \_\_\_\_\_  
 The vehicle you have purchased may differ slightly from those in the figures of this manual.

## GENERAL INFORMATION

---

### IDENTIFICATION CODE

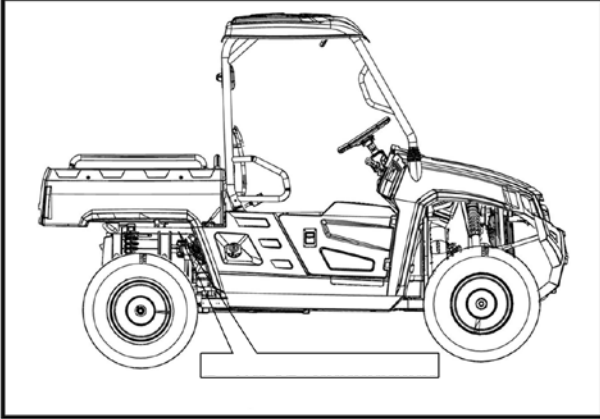

#### **Frame No.**

Frame No. is carved on the right side of front main frame

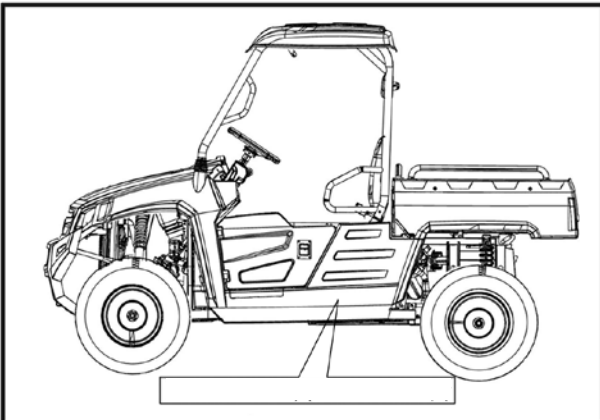

#### **Engine No.**

Engine NO. Is carved on the right side of the engine, Figure.

## GENERAL INFORMATION

---

### SAFETY

Professional mechanics can work for years and never sustain a serious injury or mishap. Follow these guidelines and practice common sense to safely service the utility terrain vehicles.

1. Do not operate the utility terrain vehicles in an enclosed area. The exhaust gasses contain carbon monoxide, an odorless, colorless and tasteless poisonous gas. Carbon monoxide levels build quickly in small enclosed areas and can cause unconsciousness and death in a short time. Make sure to properly ventilate the work area or operate the UTV side.
2. Never use gasoline or any extremely flammable liquid to clean parts. Refer to *cleaning parts and handling Gasoline Safely in this section*.
3. Never smoke or use a torch in the vicinity of flammable liquids, such as gasoline or cleaning solvent.
4. If welding or brazing on the UTV, the fuel tank to a safe distance at least 50ft. (15m) away.
5. Use the correct type and size of tools to avoid damaging fasteners.
6. Keep tools clean and in good condition. Replace or repair worn or damaged equipment.
7. When loosening a tight fastener, be guided by what would happen if the tool slips.
8. When replacing fasteners, make sure the new fasteners are the same size and strength as the original ones.
9. Keep the work area clean and organized.
10. Wear eye protection anytime the safety of the eyes is in question. This includes procedures that involve drilling, grinding, hammering, compressed air and chemicals.
11. Wear the correct clothing for the job. Tie up or cover long hair so it does not get caught in moving equipment.
12. Do not carry sharp tools in clothing pockets.
13. Always have an approved fire extinguisher available. Make sure it is rated for gasoline (Class B) and electrical (Class C) fires.
14. Do not use compressed air to clean clothes, the UTV or the work area. Debris may be blown into the eyes or skin. Never direct compressed air at anyone. Do not allow children to use or play with any compressed air equipment.
15. When using compressed air to dry rotating parts, hold the part so it does not rotate. Do not allow the force of the air to spin the part. The air jet is capable of rotating parts at extreme speed. The part may disintegrate or become damaged, causing serious injury.
16. Do not inhale the dust created by brake pad and clutch wear. These particles may contain asbestos. In addition, some types of insulating materials and gaskets may contain asbestos. Inhaling asbestos particles is hazardous to one's health.
17. Never work on the UTV while someone is working under it.

### Handling Gasoline Safely

Gasoline is a volatile flammable liquid and is one of the most dangerous items in the shop. Because gasoline is used so often, many people forget it is hazardous. Only use gasoline as fuel for gasoline internal combustion engines. Keep in mind when working on the machine, gasoline is always present in the fuel tank, fuel line, throttle. To avoid a disastrous accident when working around the fuel system, carefully observe the following precautions:

1. Never use gasoline to clean parts. Refer to *Cleaning Parts* in this section.

## **GENERAL INFORMATION**

---

2. When working of the fuel system, work outside or in a well-ventilated area.
3. Do not add fuel to the fuel tank or service the fuel system while the UTV is near open flames, sparks or where someone is smoking .Gasoline vapor is heavier than air, it collects in low areas and is more easily ignited than liquid gasoline.
4. Allow the engine to cool completely before working on any fuel system component.
5. Do not store gasoline in glass containers. If the glass breaks, a serious explosion of fire may occur.
6. Immediately wipe up spilled gasoline with rags. Store the rags in a metal container with a lid until they can be properly disposed of, or place them outside in a safe place for the fuel to evaporate.
7. Do not pour water onto a gasoline fire. Water spreads the fire and makes it more difficult to put out. Use a class B, BC or ABC fire extinguisher which are dedicated to extinguish the gasoline fire.
8. Always turn off the engine before refueling. Do not spill fuel onto the engine or exhaust system. Do not overfill the fuel tank. Leave an air space at the top of the tank to allow room for the fuel to expand due to temperature fluctuations.

### **Cleaning Parts**

Cleaning parts is one of the more tedious and difficult service jobs performed in the home garage. Many types of chemical cleaners and solvents are available for shop use. Most are poisonous and extremely flammable. To prevent chemical exposure, vapor buildup, fire and serious injury, observe each product warning label and note the following:

1. Read and observe the entire product label before using any chemical. Always know what type of chemical is being used and whether it is poisonous and/or flammable.
2. Do not use more than one type of cleaning solvent at a time. If mixing chemicals is required, measure the proper amounts according to the manufacturer.
3. Work in a well-ventilated area.
4. Wear chemical-resistant gloves.
5. Wear safety glasses.
6. Wear a vapor respirator if the instructions call for it.
7. Wash hands and arms thoroughly after cleaning parts.
8. Keep chemical products away from children and pets.
9. Thoroughly clean all oil, grease and cleaner residue from any part that must be heated.
10. Use a nylon brush when cleaning parts. Metal brushes may cause a spark.
11. When using a parts washer, only use the solvent recommended by the manufacturer. Make sure the parts washer is equipped with a metal lid that will lower in case of fire.

### **Warning Labels**

Most manufacturers attach information and warning labels to the UTV. These labels contain instructions that are important to personal safety when operating, servicing, transporting and storing the UTV. Refer to the owner's manual for the description and location of labels. Order replacement labels from the dealers or manufacturer if they are missing or damaged.

## GENERAL INFORMATION

---

### SERIAL NUMBERS

Serial and identification numbers are stamped on various locations on the frame engine throttle body. Record these numbers in the Quick Reference Data section in the front of the manual. Have these numbers available when ordering parts.

### FASTENERS

Proper fastener selection and installation is important to ensure the motorcycle operates as designed and can be serviced efficiently. The choice of original equipment fasteners is not arrived at by chance. Make sure replacement fasteners meet all the same requirements as the originals

Many screws. Bolts and studs are combined with nuts to secure particular components. to indicate the size of a nut. Manufactures specify the internal diameter and the thread pitch

The measurement across two flats on a nut or bolt indicates the wrench size

#### **WARNING**

*Do not install fasteners with a strength classification lower than what was originally installed by the manufacturer doing so may cause equipment failure and or damage*

### Torque Specifications

The material used in the manufacturing of the UTV may be subjected to uneven stresses if the fasteners of the various subassemblies are not installed and tightened correctly. Fasteners that are improperly installed or work loose can cause extensive damage. it is essential to use an accurate torque wrench as described in this chapter

### Self-Locking Fasteners

Several types of bolts. Screws and nuts incorporate a system that creates interference between the two fasteners. Interference is achieved in various ways. The most common types are the nylon insert nut and a dry adhesive coating on the threads of a blot.

Self-locking fasteners offer greater holding strength than standard fasteners, which improves their resistance to vibration. All self-locking fasteners cannot be reused. The materials used to from the lock become distorted after the initial installation and removal. Discard and replace self-locking fasteners after removing them. Do not replace self-locking fasteners with standard fasteners.

### Washers

The two basic types of washers are flat washers and lock washers. Flat washers are simple discs with a hole to fit a screw or bolt. Lock washers are used to prevent a fastener from working loose. Washers can be used as spacers and seals. Or can help distribute fastener load and prevent the fastener from damaging the component

As with fasteners. When replacing washers make sure the replacement washers are of the same design and quality

## GENERAL INFORMATION

### Cotter Pins

A cotter pin is a split metal pin inserted into a hole or slot to prevent a fastener from loosening. In certain applications, such as the rear axle on an UTV or motorcycle, the fastener must be secured in this way. For these applications, a cotter pin and castellated (slotted) nut is used.

To use a cotter pin, first make sure the diameter is correct for the hole in the fastener. After correctly tightening the fastener and aligning the holes, insert the cotter pin through the hole and bend the ends over the fastener. Unless instructed to do so, never loosen a tightened fastener to align the holes. If the holes do not align, tighten the fastener enough to achieve alignment.

Cotter pins are available in various diameters and lengths. Measure the length from the bottom of the head to the tip of the shortest pin.

### Snap Rings and E-clips

Snap rings (**Figure 1**) are circular-shaped metal retaining clips. They secure parts in place on parts such as shafts. External type snap rings are used to retain items on shafts. Internal type snap rings secure parts within housing bores. In some applications, in addition to securing the component(s), snap rings of varying thicknesses also determine endplay. These are usually called selective snap rings.

The two basic types of snap rings are machined and stamped snap rings. Machined snap rings (**Figure 2**) can be installed in either direction. Because both faces have sharp edges. Stamped snap rings (**Figure 3**) are manufactured with a sharp and a round edge. When installing a stamped snap ring in a thrust application, install the sharp edge facing away from the part producing the thrust.

E-clips are used when it is not practical to use a snap ring. Remove E-clips with a flat blade screwdriver by prying between the shaft and E-clip. To install an E-clip, center it over the shaft groove and push or tap it into place.

Observe the following when installing snap rings:

1. Remove and install snap rings with snap ring pliers. Refer to *Basic Tools* in this chapter.
2. In some applications, it may be necessary to replace snap rings after removing them.
3. Compress or expand snap rings only enough to install them. If overly expanded, lose their retaining ability.
4. After installing a snap ring, make sure it seats completely.
5. Wear eye protection when removing and installing snap rings.

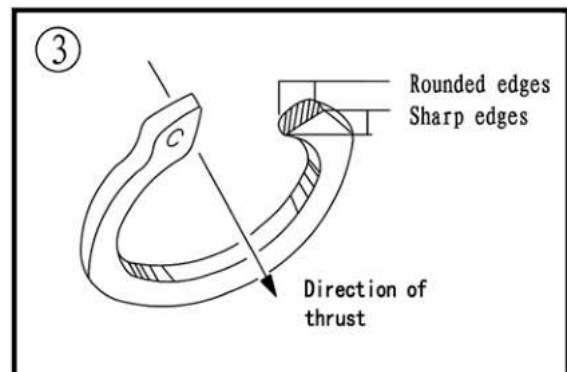
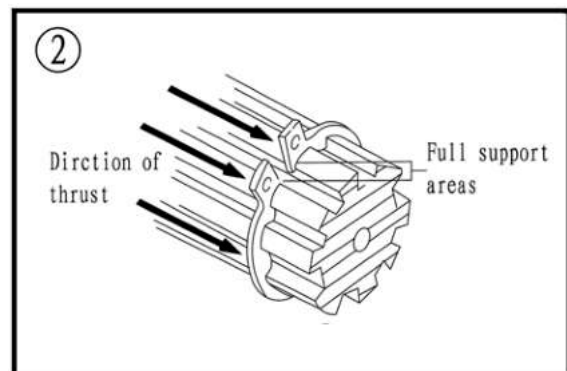
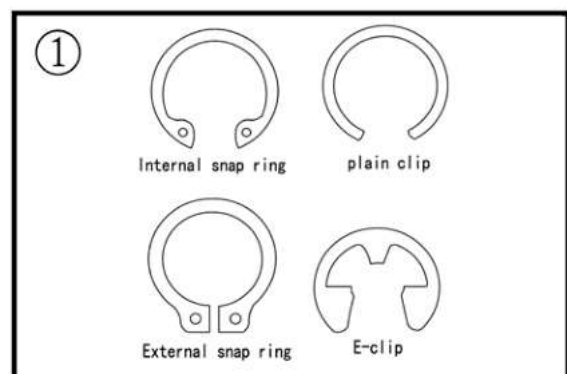

## GENERAL INFORMATION

---

### SHOP SUPPLIES

#### Lubricants and Fluids

Periodic lubrication help ensure a long service life for any type of equipment. Using the correct type of lubricant is as important as performing the lubrication service. Although in an emergency the wrong type is better than not using one, The following section describes the types of lubricants most often required. Make sure to follow the manufacturer's recommendations for lubricant types

#### Engine oils

Engine oil for four-stroke the UTV engine use is classified by two standards: the American Petroleum Institute (API) service classification. The Society of Automotive Engineers (SAE) viscosity rating Standard classification

The API and SAE information is on all oil container labels. Two letters indicate the API service classification. The number or sequence of numbers and letter (10W-40SG for example) is the oil's viscosity rating. The API service classification and the SAE viscosity index are not indications of oil quality.

The APL service classification standards, The first letter in the classification S indicates that the oil is for gasoline engines. The second letter indicates the standard the oil satisfies . The classifications are: MA (high friction applications) and MB( low friction applications).

#### **NOTE**

**Refer to Engine Oil and Filter in Chapter Three for further information on API, SAE classifications.**

Always use an oil with a classification recommended by the manufacturer, Using an oil with a different classification can cause engine damage.

Viscosity is an indication of the oil's thickness. Thin oils have a lower number while thick oil have a higher number. Engine oils fall into the 5-to50-weight range for single-grade oils.

Most manufactures recommend multi-grade oil. These oils perform efficiently across a wide range of operating conditions. Multi-grade oils are identified by a W after the first number, which indicates the low-temperature viscosity.

Engine oils are most commonly mineral (petroleum) based, but synthetic and semi-synthetic types are used more frequently. When selecting engine oil, follow the manufacturer's recommendation for type, classification and viscosity.

#### Greases

Grease is lubricating oil with thickening agents added to it. The National Lubricating Grease Institute (NLGI) grades grease. Grades range from No.000 to No.6, with No.6 being the thickest. Typical multipurpose grease is NLGI No.2. For specific applications, manufacturers may recommend water-resistant type grease or one with an additive such as molybdenum disulfide (MoS<sub>2</sub>).

## GENERAL INFORMATION

---

### Brake fluid

Brake fluid is the hydraulic fluid used to transmit hydraulic pressure (force) to the wheel brakes. Brake fluid is classified by the Department of Transportation (DOT). Current designations for brake fluid are DOT 3, DOT 4 and DOT 5, this classification appears on the fluid container.

Each type of brake fluid has its own definite characteristics. Do not intermix different types of brake fluid as this may cause brake system failure. DOT 5 brake fluid is silicone based. DOT 5 is not compatible with other brake fluids may cause brake system failure. When adding brake fluid, only use the fluid recommended by the manufacturer.

Brake fluid will damage any plastic, painted or plated surface it contacts. Use extreme care when working with brake fluid and remove any spills immediately with soap and water.

Hydraulic brake systems require clean and moisture free brake fluid. Never reuse brake fluid. Keep containers and reservoirs properly sealed.

#### **WARNING**

***Never put a mineral-based (Petroleum) oil into the brake system. Mineral oil causes rubber parts in the system to causing complete brake failure.***

### Coolant

Coolant is a mixture of water and antifreeze used to dissipate engine heat. Ethylene glycol is the most common form of antifreeze. Check the UTV Manufacturer's recommendations when selecting antifreeze. Most require one specifically designed for aluminum engines. There types of antifreeze have additives that inhibit corrosion.

Only mix antifreeze with distilled water. Impurities in tap water may damage internal cooling system passages.

### Cleaners, Degreasers and Solvents

Many chemicals are available to remove oil, grease and other residue from the UTV. Before using cleaning solvents, consider how they will be used and disposed of , particularly if they are not water-soluble. Local ordinances may types of cleaning chemicals. Refer to Safer in this chapter.

Use brake parts cleaner to brake system components. Brake parts cleaner leaves no residue. Use electrical contact cleaner is a powerful solvent used to remove fuel deposits and varnish from fuel system components. Use this cleaner carefully, as it may damage finishes.

Most solvents are designed to be used with a parts washing cabinet for individual component cleaning. For safety, use only nonflammable or high flash point solvents.

### Gasket Sealant

Sealant is used in combination with a gasket or seal. In other applications, such as between crankcase halves, only a sealant is used. Follow the manufacturer's recommendation when using a sealant. Use extreme care when choosing a sealant different sealant based on its resistance to heat, various fluids and its sealing capabilities.



## GENERAL INFORMATION

---

### Gasket Remover

Aerosol gaskets remover can help remove stubborn gasket. This product can speed up the removal process and prevent damage to the mating surface that may be caused by using a scraping tool. Most of these types of products are very caustic. Follow the gasket remover manufacturer's instructions for use.

### Thread locking Compound

A thread locking compound is a fluid applied to the threads of fasteners. After tightening the fastener, the fluid dries and becomes a solid filler between the threads. This makes it difficult for the fastener to work loose from vibration or heat expansion and contraction. Some thread locking compound sparingly. Excess fluid can run into adjoining parts.

#### CAUTION

**Thread locking compounds are anaerobic and will stress, crack and attack most plastics. Use caution when using these products in areas where there are plastic components.**

Thread locking compounds are available in a wide range of compounds for various strength, temperature and repair applications. Follow the manufacturer's recommendations regarding compound selection.

## BASIC TOOLS

Most of the procedures in this manual can be carried out with basic hand tools and test equipment familiar to the home mechanic. Always use the correct tools for the job. Keep tools organized and clean. Store them in a tool chest with related tools organized together.

Quality tools are essential. The best are constructed of high-strength alloy steel. These tools are light, easy to use and resistant to wear. Their working surface is devoid of sharp edges and carefully polished. They have an easy-to-clean finish and are comfortable to use. Quality tools are a good investment.

Some of the procedures in this manual specify special tools. In many cases the tools is illustrated in use. Those with a large tool kit may be able to replacement. However, in some cases, the specialized equipment or expertise may make it impractical for the home mechanic to attempt the procedure. When necessary, such operations are recommended to have a dealership or specialist perform the task. It may be less expensive to have a professional perform these jobs, especially when considering the cost of equipment.

When purchasing tools to perform the procedures covered in this manual, consider the tool's potential frequency of use. If a tool kit is just now being started. Consider purchasing a basic tool set from a quality tool combinations and offer substantial savings when complicated, specialized tools can be added.

## GENERAL INFORMATION

### Screwdrivers

Screwdrivers of various lengths and types are mandatory for the simplest tool kit. The two basic types are the slotted tip (flat blade) and the Phillips tip. These are available in sets that often include an assortment of tip size and shaft lengths.

As with all tools, use a screwdriver designed for the job. Make sure the size of the fastener. Use them only for driving screws. Never use a screwdriver for prying or chiseling metal. Repair or replace worn or damaged screwdrivers. A worn tip may damage the fastener, making it difficult to remove.

Phillips-head screws are often damaged by incorrectly fitting screwdrivers. Quality Phillips screwdrivers are manufactured with their crosshead tip machined to Phillips Screw Company specifications. Poor quality or damaged Phillips screwdrivers can back out (cam out) and round over the screw head. In addition, Weak or soft screw materials can make removal difficult.

The best type of screwdriver to use on Phillips screw is the ACR Phillips II screwdriver, patented by the horizontal anti-cam out ribs found on the driving faces or flutes of the screwdriver's tip (**figure 4**). ACR Phillips II screwdrivers were designed as part of a manufacturing drive system to be used with ACR Phillips II screws, but they work of tool companies offer ACR Phillips II screwdrivers in different Tip size and interchangeable bits to fit screwdriver bit holders.

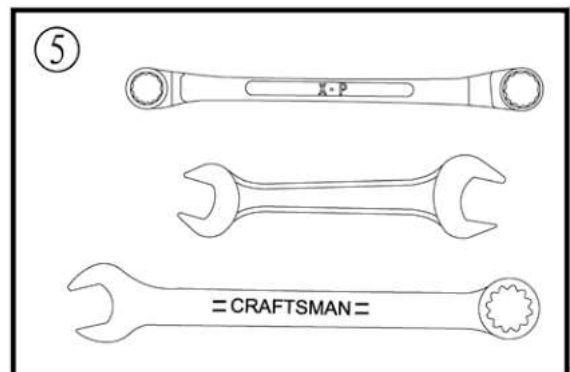
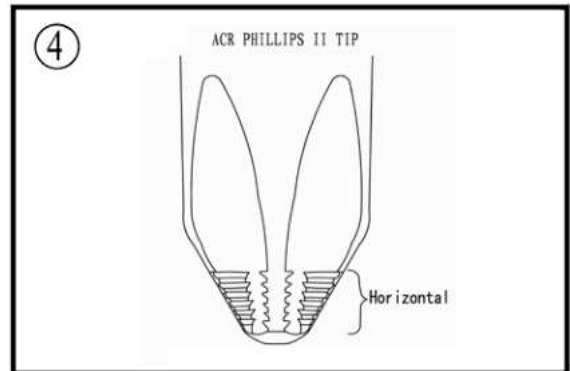

#### NOTE

**Another way to prevent cam out and to increase the grip of a Phillips screwdriver is to apply valve grinding compound or permute screw & socket Gripper onto the screwdriver tip. After loosening/tightening the screw, clean the screw recess to prevent engine oil contamination.**

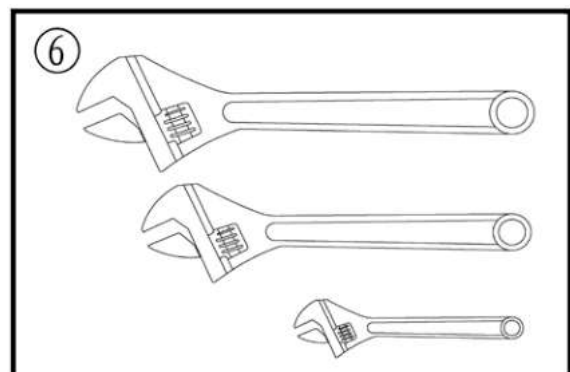

### Wrenches

Open-end, box-end and combination wrenches (**figure 5**) are available in a variety of types and sizes.

The number stamped on the wrench refers to the distance of the fastener head.

The box-end wrench is an excellent tool because it grips the fastener on all sides. This reduces the chance of the tool slipping. The box-end wrench is designed with either a 6 or 12-point opening. For stubborn or damaged fasteners, the 6-point provides superior holding because it contacts the fastener across a wider area at all six edges. For general use, the 12-point works well. It allows the wrench to be removed and reinstalled without moving the handle over such a wide area.

## GENERAL INFORMATION

An open-end wrench is fast and works best in areas with limited overhead access. It contacts the fastener at only two points and is subject to slipping if under heavy force, or if the tool or fastener is worn. A box-end wrench is preferred in most instances, especially when braking loose and applying the final tightness to a fastener.

The combination wrench has a box-end on one end and an open-end on one end and an open-end on the other. This combination makes it a convenient tool.

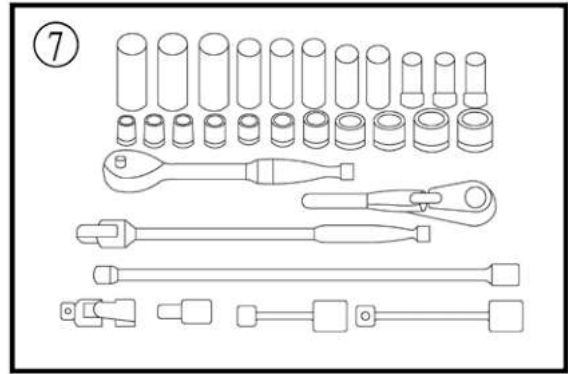

### Adjustable wrenches

An adjustable wrench or Crescent wrench (**Figure 6**) can fit nearly any nut or bolt head that has clear access around its entire perimeter. An adjustable wrench is best used as a backup wrench to keep a large nut or bolt from turning while the other end is being loosened or tightened with a box-end or socket wrench.

Adjustable wrenches contact the fastener at only two points, which makes them more subject to slipping off the fastener. Because one jaw is adjustable and may become loose, this shortcoming is aggravated. Make certain the solid jaw is the one transmitting the force.

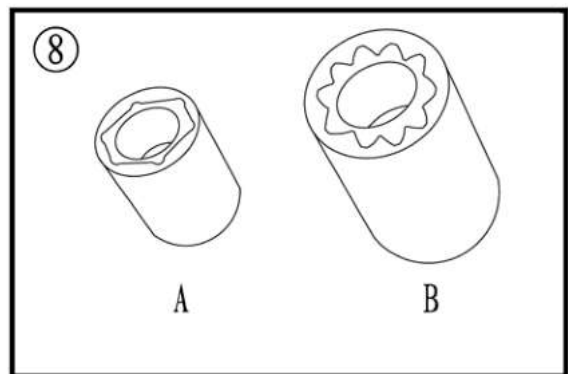

### Socket Wrenches, Ratchets and Handles

Sockets that attach to a ratchet handle (**Figure 7**) are available with 6-point or 12-point openings (**Figure 8**) and different drive sizes. The drive size indicates the size of the square hole that accepts the ratchet handle. The number stamped on the socket is the size of the work area and must be the fastener head

As with wrenches, a 6-point provides superior-holding ability. While a 12-point socket needs to be moved only half as far to reposition it on the fastener.

Sockets are designated for either hand or impact use. Impact sockets are made of thicker material for more durability. Compare the size and wall thickness of a 19-mm hand socket (A, **Figure 9**) and the 19-mm impact socket (B). Use impact sockets when using an impact driver or air tools. Use hand sockets with hand-driven attachments

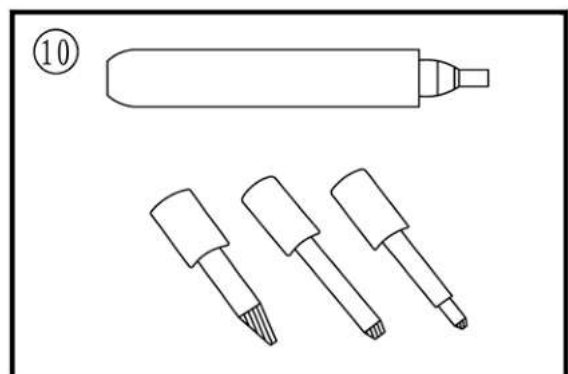
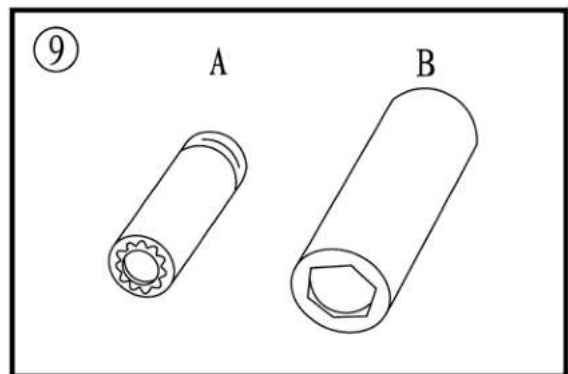

## GENERAL INFORMATION

### **WARNING**

***Do not use hand sockets with air or impact tools because they may shatter and cause injury. Always wear eye protection when using impact or air tools***

Various handles are available for sockets. Use the speed handle for fast operation. Flexible ratchet heads in varying length allow the socket to be turned with varying force and at odd angles. Extension bars allow the socket setup to reach difficult areas. The ratchet is the most versatile. It allows the user to install or remove the nut without removing the socket

Sockets combined with any number of drivers make them undoubtedly the fastest, safest and most convenient tool for fastener removal and installation

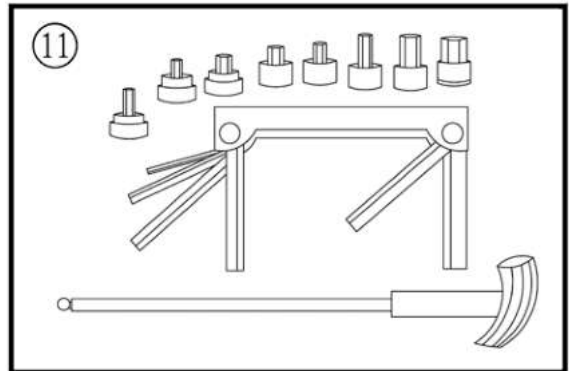

### **Impact Drivers**

An impact driver provides extra force for removing fasteners by converting the impact of a hammer into a turning motion. This makes it possible to remove stubborn fasteners without damaging them. Impact drivers and interchangeable bits (**Figure 10**) are available from most tool suppliers. When using a socket with an impact driver, make sure the socket is designed for impact use. Refer to *Socket Wrenches, Ratchets and handles* in this section.

### **WARNING**

***Do not use hand sockets with air or impact tools because they may shatter and cause injury. Always wear eye protection when using impact or air tools***

### **Allen Wrenches**

Use Allen or setscrew wrenches (**Figure 11**) on fasteners with hexagonal recesses in the fastener head. These wrenches are available in L-shaped bar, socket and T-handle types. A metric set is required when working on most motorcycles. Allen bolts are sometimes called socket bolts.

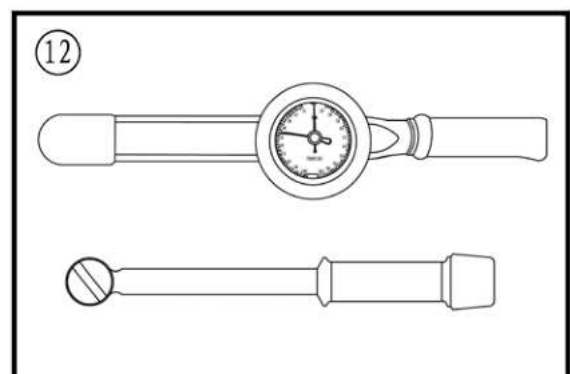

### **Torque Wrenches**

Use a torque wrench with a socket, torque adapter or similar extension to tighten a fastener to a measured torque. Torque wrenches come in several drive sizes (1/4, 3/8, 1/2 and 3/4) and have various methods of reading the torque value. The drive size indicates the size of the square drive that

## GENERAL INFORMATION

accepts the socket, adapter or extension. Common methods of reading the torque value are the deflecting beam, the dial indicator and the audible click (**Figure 12**).

When choosing a torque wrench, consider the torque range, drive size and accuracy. The torque specifications in this manual provide an indication of the range required.

A torque wrench is a precision tool that must be properly cared for to remain accurate. Store torque wrenches in cases or separate padded drawers within a toolbox. Please refer to the followed manufacturer's instructions for their care and calibration.

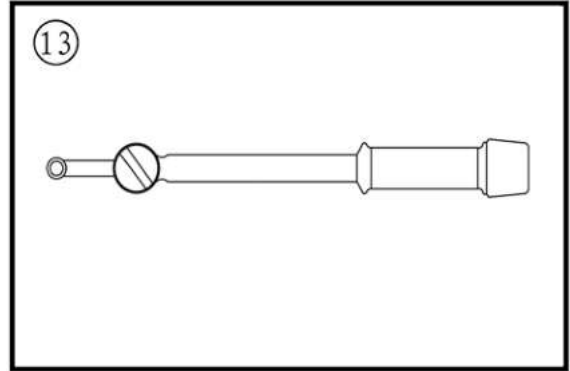

### Torque Adapters

Torque adapters or extensions extend or reduce the reach of a torque wrench. The torque adapter shown in (**Figure 13**) is used to tighten a fastener that cannot be reached because of the size of the torque wrench head, drive, and socket. If a torque adapter changes the effective lever length (**Figure 14**), the torque reading on the wrench will not equal the actual torque applied to the fastener. It is necessary to recalibrate the torque setting on the wrench to compensate for the change of lever length. When using a torque adapter at a right angle to the drive head, calibration is not required, because the effective length has not changed.

To recalculate a torque reading when using a torque adapter, use the following formula and refer to **Figure 14**:

$$TW = \frac{TA \times L}{L+A}$$

*TW* is the torque setting or dial reading on the wrench.

*TA* is the torque specification and the actual amount of torque that is applied to the fastener.

*A* is the amount that the adapter increases (or in some cases reduces) the effective lever length as measured along the centerline of the torque wrench.

*L* is the lever length of the wrench as measured from the center of the drive to the center of the grip.

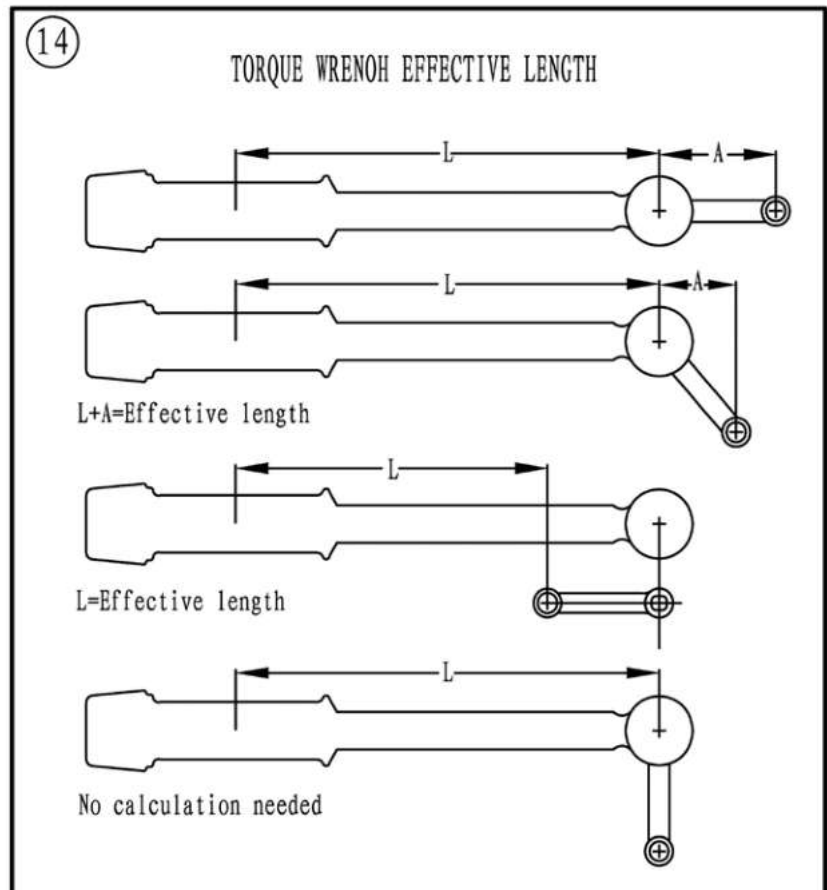

## GENERAL INFORMATION

The effective length is the sum of L and A.

Example:

$$TA=20 \text{ ft.-lb.}$$

$$A=3 \text{ in.}$$

$$L=14 \text{ in.}$$

$$TW = \frac{20 \times 14 = 280}{14 + 3 = 17} = 16.5 \text{ ft. - lb.}$$

In this example, the torque wrench would be set to the recalculated torque value (TW = 16.5 ft. –lb.). When using a beam-type wrench, tighten the fastener until the pointer aligns with 16.5 ft. –lb. In this example, although the torque wrench is pre set to 16.5 ft. –lb., the actual torque is 20 ft. –lb.

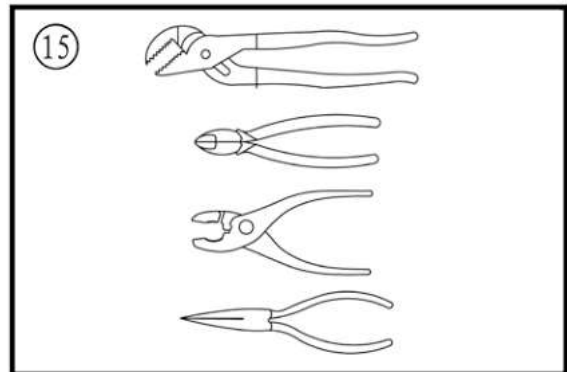

### Pliers

Pliers come in a wide range of types and sizes. Pliers are useful for holding, cutting, bending, and crimping. Do not use them to turn fasteners. **Figure 15** and **Figure 16** show several types of useful pliers. Each design has a specialized function. Slip-joint pliers are general – purpose pliers used for gripping and bending. Diagonal cutting pliers are needed to cut wire and can be used to remove cotter pins. Use needle nose pliers to hold or bend small objects. Locking pliers (**Figure 16**), sometimes called Vise-Grips, are used to hold objects very tightly. They have many uses ranging from holding two parts together, to gripping the end of a broken stud. Use caution when using locking pliers, as the sharp jaws will damage the objects they hold.

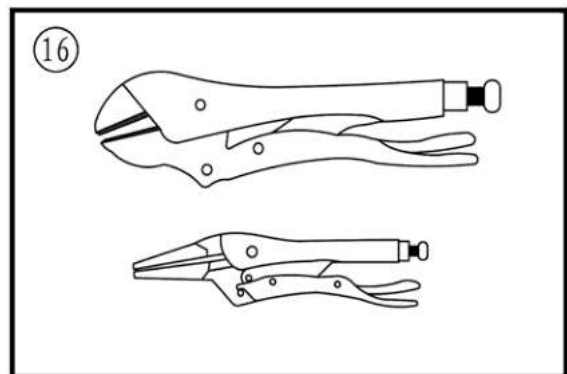

### Snap Ring Pliers

Snap ring pliers are specialized pliers with tips that fit into the ends of snap rings to remove and install them.

Snap ring pliers (**Figure 17**) are available with a fixed action (either internal or external ) or convertible (one tool works on both internal and external snap rings). They may have fixed tips or interchangeable ones of various sizes and angles. For general use, select a convertible type pliers with interchangeable tips (**Figure 17**).

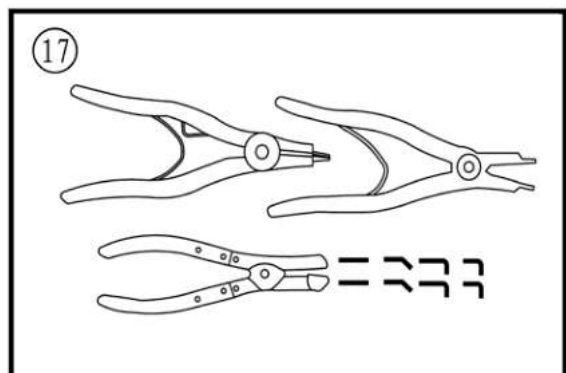

### **WARNING**

***Snap rings can slip and fly off when removing and installing them. Also, the snap ring pliers tips may break.***

## GENERAL INFORMATION

*Always wear eye protection when using snap ring pliers.*

### Hammers

Various types of hammers are available to fit a number of applications. Use a ball-peen hammer to strike another tool, such as a punch or chisel. Use soft-faced hammers when a metal object must be struck without damaging it. Never use a metal-faced hammer on engine and suspension components because damage occurs in most cases.

Always wear eye protection when using hammers. Make sure the hammer face is in good condition and the handle is not cracked. Select the correct hammer for the job and make sure to strike the object squarely. Do not use the handle or the side of the hammer to strike an object.

### Ignition Grounding Tool

Some test procedures require turning the engine over without starting it. To prevent damage to the ignition system from excessive resistance or the possibility of fuel vapor being ignited by an open spark, remove the spark plug cap and ground it directly to a good engine ground with the tool shown in **(Figure 18)**.

Make the tool shown from a No.6 screw and nut, two washers, length of tubing, alligator clip, electrical eyelet and a length of wire.

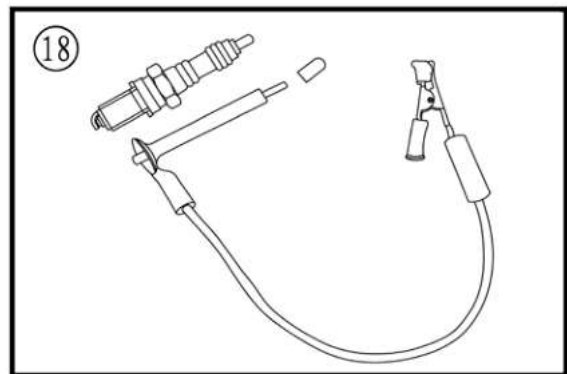

## PRECISION MEASURING TOOLS

The ability to accurately measure components is essential to perform many of the procedures described in this manual. Equipment is manufactured to close tolerances, and obtaining consistently accurate measurements is essential to determine which components require replacement or further service.

Each type of measuring instrument is designed to measure a dimension with a certain degree of accuracy and within a certain range. When selecting the measuring tool, make sure it is applicable to the task.

As with all tools, measuring tools provide the best results if cared for properly. Improper use can damage the tool and cause inaccurate results. If any measurement is questionable, verify the measurement using another tool. A standard gauge is usually provided with micrometers to check accuracy and calibrate the tool if necessary.

Precision measurements can vary according to the experience of the person performing the procedure. Accurate results are only possible if the mechanic possesses a feel for using the tool. Heavy-handed use of measuring tools produces less accurate results. Hold the tool gently by the fingertips to easily feel the point at which the tool contacts the object. This feel for the equipment produces more accurate measurements and reduces the risk of damaging the tool or component. Refer to the following sections for specific measuring tools.

## GENERAL INFORMATION

### Feeler Gauge

Use feeler or thickness gauges (**Figure 19**) for measuring the distance between two surfaces.

A feeler gauge set consists of an assortment of steel strips of graduated thickness. Each blade is marked with its thickness. Blades can be of various lengths and angles for different procedures.

A common use for a feeler gauge is to measure valve clearance. Use wire (round) type gauges to measure spark plug gap.

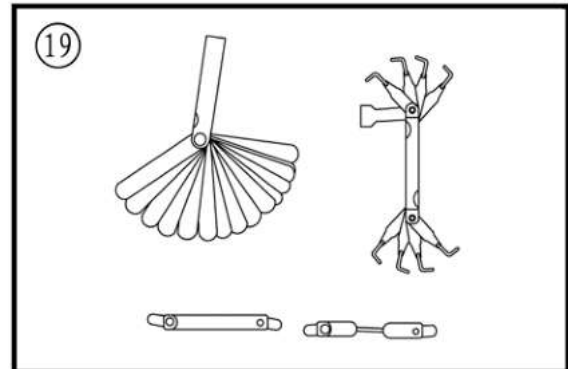

### Calipers

Calipers (**Figure 20**) are excellent tools for obtaining inside, outside and depth measurements. Although not as precise as a micrometer, they allow reasonable precision, typically to within 0.02mm or 0.05 mm (0.001 in.). Most calipers have a range up to 150 mm (6 in.).

Calipers are available in dial, vernier or digital versions. Dial calipers have a dial readout that provides convenient reading. Vernier calipers have marked scales that must be compared to determine the measurement. The digital caliper uses a liquid-crystal display (LCD) to show the measurement.

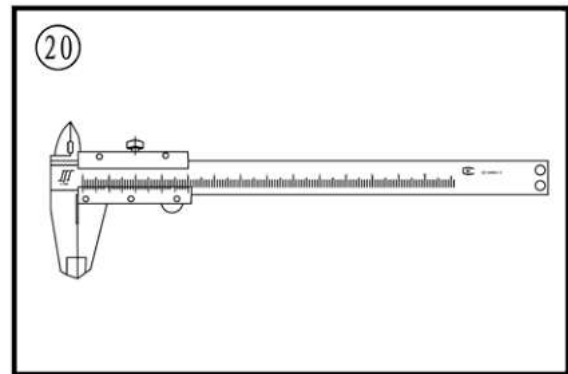

Properly maintain the measuring surfaces of the caliper. There must not be any dirt or burrs between the tool and the object being measured. Never force the caliper to close around an object. Close the caliper around the highest point so it can be removed with a slight drag. Some calipers require calibration. Always refer to the manufacturer's instructions when using a new or unfamiliar caliper.

To read a vernier. Calipers refer to **Figure 21**. The fixed scale is marked in 1-mm increments. Ten individual lines on the fixed scale equal 1 cm. The movable scale is marked in 0.05 mm (hundredth) increments. To obtain a reading, establish the first number by the location of the 0 line on the movable scale in relation to the first line to the left on the fixed scale. In this example, the number is 10 mm. To determine the next number, note which of the lines on the movable scale align with a mark on the fixed scale.

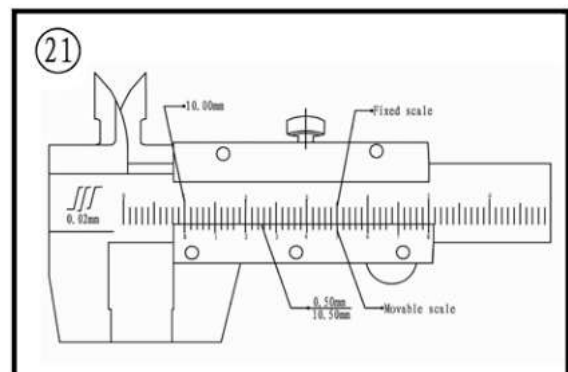

A number of lines will seem close, but only one will align exactly. In this case, 0.50 mm is the reading to add to the first number. Adding 10 mm and 0.50 mm equals a measurement of 10.50 mm.



## GENERAL INFORMATION

### Micrometers

A micrometer is an instrument designed for linear measurement using the decimal divisions of the inch or meter (**Figure 22**). While there are many types and styles of micrometers, most of the

22 DECIMAL PLACE VALUES*	
0.1	Indicates 1/10 (one tenth of an inch or millimeter)
0.01	Indicates 1/100 (one one-hundredth of an inch or millimeter)
0.001	Indicates 1/1000 (one one-thousandth of an inch or millimeter)

\*This chart represents the values of figures placed to the right of the decimal point. Use it when reading decimals from one-tenth to one one-thousandth of an inch or millimeter. It is not a conversion chart (for example: 0.001 in. is not equal to 0.001 mm).

procedures in this manual call for an outside micrometer. Use the outside micrometer to measure the outside diameter of cylindrical forms and the thickness of materials.

A micrometer's size indicates the minimum and maximum size of a part that it can measure. The usual sizes (**Figure 23**) are 0-25mm (0-1 in.), 25-50 mm (1-2 in.), 50-75 mm (2-3 in.) and 75-100 mm (3-4 in.).

Micrometers that cover a wider range of measurements are available. These use a large frame with interchangeable anvils of various lengths. This type of micrometer offers a cost savings, but its overall size may make it less convenient.

When reading a micrometer, numbers are taken from different scales and added together. The following sections describe how to adjust, care for and read the measurements of various types of outside micrometers.

For accurate results, properly maintain the measuring surfaces of the micrometer. There cannot be any dirt or burrs between the tool and the measured object. Never force the micrometer to close around an object. Close the micrometer around the highest point so it can be removed with a slight drag.

### Adjustment

Before using a micrometer, check its adjustment as follows:

1. Clean the anvil and spindle faces.
- 2A. To check a 0-1 in. or 0-25 mm micrometer:
  - a. Turn the thimble until the spindle contacts the anvil. If the micrometer has a ratchet stop, use it to ensure that the proper amount of pressure is applied.

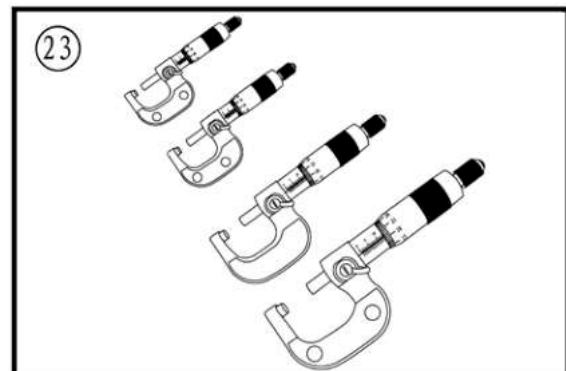

## GENERAL INFORMATION

- b. If the adjustment is correct, the 0 mark on the thimble will align exactly with the 0 mark on the sleeve line. If the marks do not align, the micrometer is out of adjustment.
  - c. Follow the manufacturer's instructions to adjust the micrometer.
- 2B. To check a micrometer larger than 1 in. or 25 mm use the standard gauge supplied by the manufacturer. A standard gauge is a steel block, disc or rod that is machined to an exact size.
- a. Place the standard gauge between the spindle and anvil, and measure its outside diameter or length. If the micrometer has a ratchet stop, use it to ensure that the proper amount of pressure is applied.
  - b. If the adjustment is correct, the 0 mark on the thimble will align exactly with the 0 mark on the sleeve line. If the marks do not align, the micrometer is out of adjustment.
  - c. Follow the manufacturer's instructions to adjust the micrometer.

## Care

Micrometers are precision instruments. They must be used and maintained with great care. Note the following:

1. Store micrometers in protective cases or separate padded drawers in a tool box.
2. When in storage, make sure the spindle and anvil faces do not contact each other or another object. If they do, temperature changes and corrosion may damage the contact faces.
3. Do not clean a micrometer with compressed air. Dirt forced into the tool will cause wear.
4. Lubricate micrometers with WD-40 to prevent corrosion.

## Metric micrometer

The standard metric micrometer (**Figure 24**) is accurate to one one-hundredth of a millimeter (0.01 mm). The sleeve line is graduated in millimeter and half millimeter increments. The marks on the upper half of the sleeve line equal 1.00 mm. Each fifth mark above the sleeve line is identified with a number. The number sequence depends on the size of the micrometer. A 0-25 mm micrometer, for example, will have sleeve marks numbered 0 through 25 in 5 mm increments. This numbering sequence continues with larger micrometers. On all metric micrometers, each mark on the lower half of the sleeve equals 0.50 mm.

The tapered end of the thimble has 50 lines marked around it. Each mark equals 0.01 mm. One complete turn of the thimble aligns its 0 mark with the first line lower half of the sleeve line or 0.50mm.

When reading a metric micrometer, add the number of millimeters and half-millimeters on the sleeve line to the number of one one-hundredth millimeters on the thimble. Perform the following steps

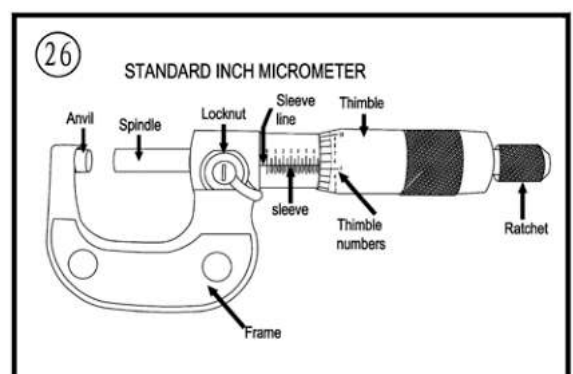
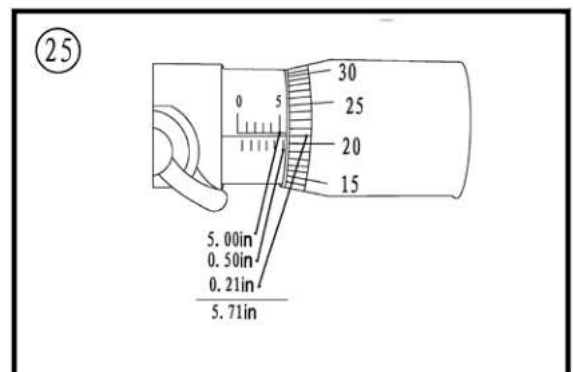
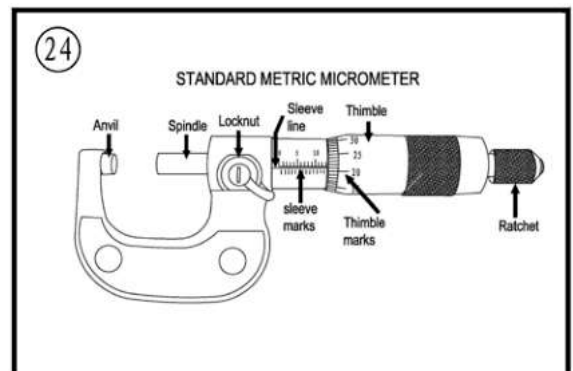

## GENERAL INFORMATION

while referring to **Figure 25**.

1. Read the upper half of the sleeve line and count the number of lines visible. Each upper line equals 1mm.
2. See if the half –millimeter line is visible on the lower sleeve line. If so, add 0.50mm to the reading in Step 1.
3. Read the thimble mark that aligns with the sleeve line. Each thimble mark equals 0.01mm.

### NOTE

**If a thimble mark does not align exactly with the sleeve line. Estimate the amount between the lines. For accurate readings in two-thousandths of a millimeter (0.002mm), use a metric vernier micrometer.**

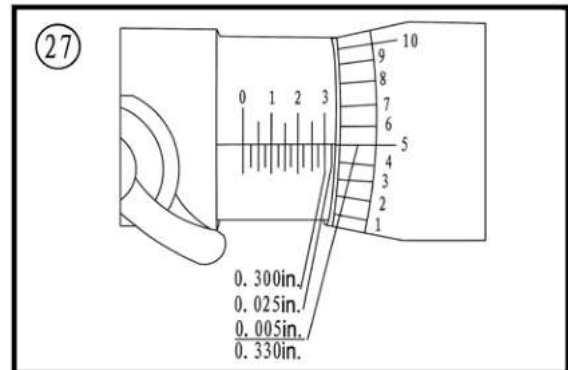

4. Add the readings from Steps 1-3.

## Standard inch micrometer

The standard inch micrometer (**Figure 26**) is accurate to one-thousandth of an inch or 0.001. The sleeve is marked in 0.025 in. increments. Every fourth sleeve mark is numbered 1,2,3,4,5,6,7,8,9. These numbers indicate 0.100, 0.200, 0.300, and so on.

The tapered end of the thimble has 25 lines marked around it. Each mark equals 0.001 in. One complete turn of the thimble will align its zero mark with the first mark on the sleeve or 0.025 in.

To read a standard inch micrometer, perform the following steps and refer to **Figure 27**.

1. Read the sleeve and find the largest number visible. Each sleeve number equals 0.100 in.
2. Count the number of lines between the numbered sleeve mark and the edge of the thimble. Each sleeve mark equals 0.025 in.
3. Read the thimble mark that aligns with the sleeve line. Each thimble mark equals 0.01 in.

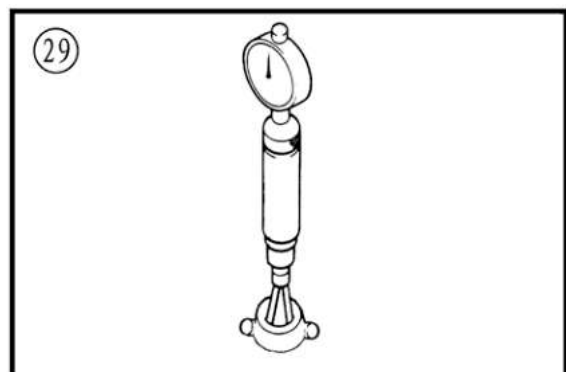
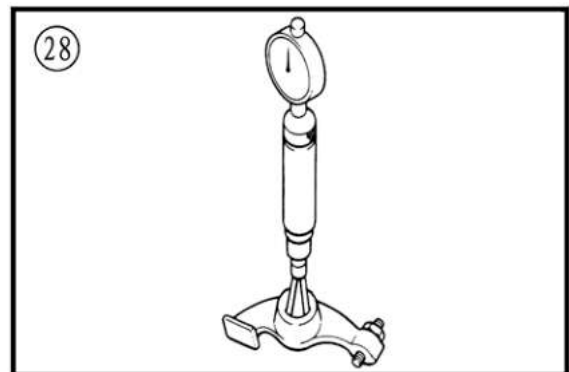

### NOTE

**If a thimble mark does not align exactly with the sleeve line, estimate the amount between the lines. For accurate readings in ten-thousandths of an inch (0.0001 in), use a vernier inch micrometer.**

4. Add the readings from Steps 1-3.

## GENERAL INFORMATION

### Telescoping and Small Bore Gauges

Use telescoping gauges (**Figure 28**) and small bore gauges (**Figure 29**) to measure bores. Neither gauge has a scale for direct readings. Use an outside micrometer to determine the reading.

To use a telescoping gauge, select the correct size gauge for the bore. Compress the movable post and carefully insert the gauge into the bore. Carefully move the gauge in the bore to make sure it is centered. Tighten the knurled end of the gauge to hold the movable post in position. Remove the gauge and measure the length of the posts. Telescoping gauges are typically used to measure cylinder bores.

To use a small bore gauge, select the correct size gauge for the bore. Carefully insert the gauge into the bore. Tighten the knurled end of the gauge to carefully expand the gauge fingers to the limit within the bore. Do not over tighten the gauge because there is no built-in release. Excessive tightening can damage the bore surface and damage the tool. Remove the gauge and measure the outside dimension (**Figure 30**). Small bore gauges are typically used to measure valve guides.

### Dial Indicator:

A dial indicator (**Figure 31**) is a gauge with a dial face and needle used to measure variations in dimensions and movements. Measuring brake rotor runout is a typical use for a dial indicator.

Dial indicators are available in various ranges and graduations and with three basic types of mounting bases: magnetic (B, **Figure 31**). Clamp, or screw-in stud. When purchasing a dial indicator, select one with a continuous dial (A, **Figure 31**).

### Cylinder Bore Gauge

A cylinder bore gauge is similar to a dial indicator. The gauge set shown in **Figure 32** consists of a dial indicator, handle, and different length adapters (anvils) to fit the gauge to various bore sizes. The bore gauge is used to measure bore size, taper and out-of-round. When using a bore gauge, follow the manufacturer's instructions.

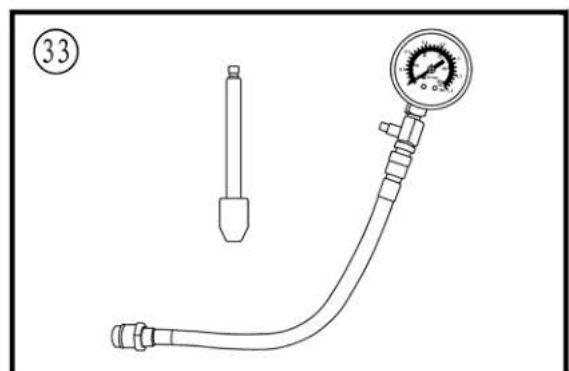
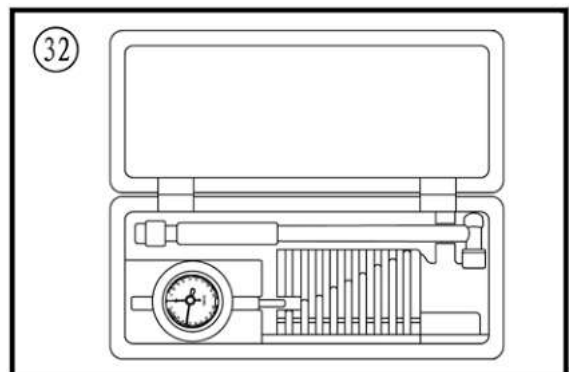
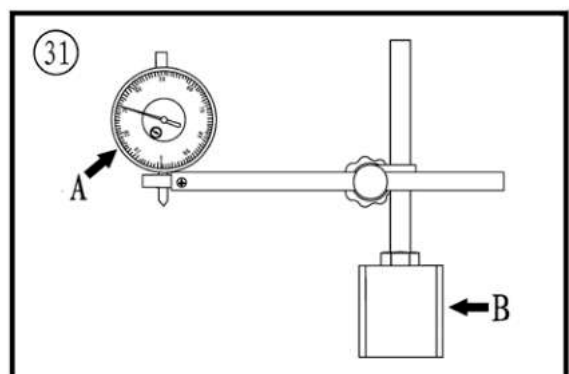
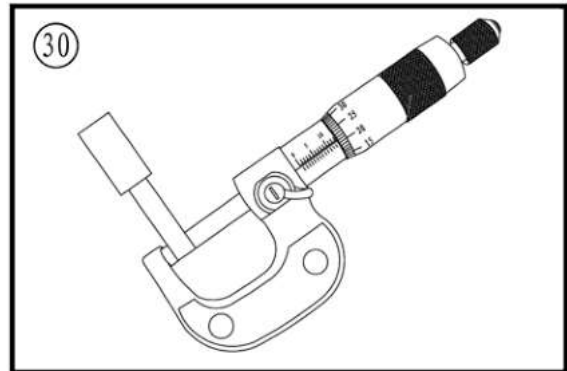

## GENERAL INFORMATION

### Compression Gauge

A compression gauge (**Figure 33**) measures combustion chamber (cylinder) pressure, usually in PSI or kg/ cm<sup>2</sup>. The gauge adapter is either inserted or screwed into the spark plug hole to obtain the reading. Disable the engine so it does not start and hold the throttle in the wide-open position when performing a compression test. An engine that does not have adequate compression cannot be properly tuned. Refer to Chapter Three.

### Multimeter

A multimeter (**Figure 34**) is an essential tool for electrical system diagnosis. The voltage function indicates the voltage applied or available to various electrical components. The ohmmeter function tests circuits for continuity, or lack of continuity, and measures the resistance of a circuit.

Some manufacturer's specifications for electrical components are based on results using a specific test meter. Results may vary if using a meter not recommended by the manufacturer. Such requirements are noted when applicable.

#### *Ohmmeter (analog) calibration*

Each time an analog ohmmeter is used or if the scale is changed, the ohmmeter must be calibrated.

Digital ohmmeters do not require calibration.

1. Make sure the meter battery is in good condition.
2. Make sure the meter probes are in good condition.
3. Touch the two probes together and observe the needle location on the ohms scale. The needle must align with the 0 mark to obtain accurate measurements.
4. If necessary, rotate the meter ohms adjust knob until the needle and 0 mark align.

### Clip-on ammeter

1. Clip-on ammeter (**Figure 35**) is the basic tool for electrical system diagnosis which is used to measure the current of charging system and other electrical components work current.
2. Clip-on ammeter can measure direct current and alternating current. Please ensure that the instrument battery capacity is sufficient when work.
3. When measure the current, the calliper must seize the positive pole of the power. If seize the negative pole mistakenly, wrong result will appear.

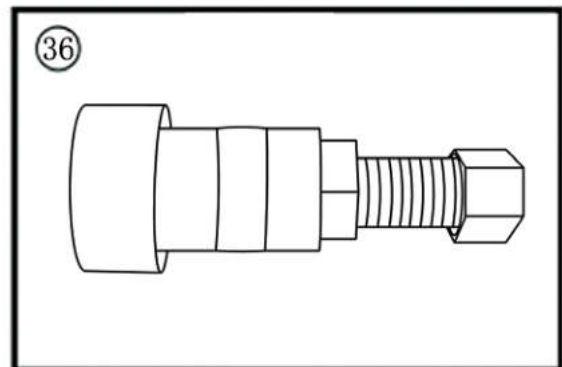
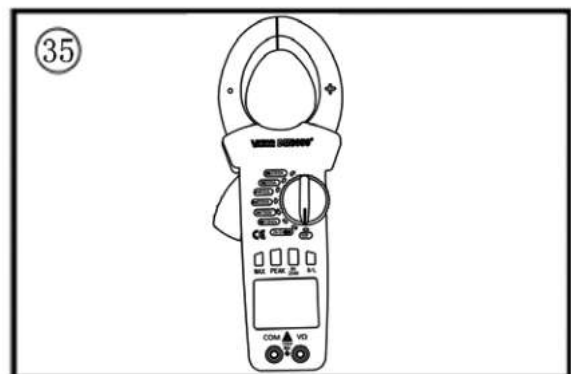
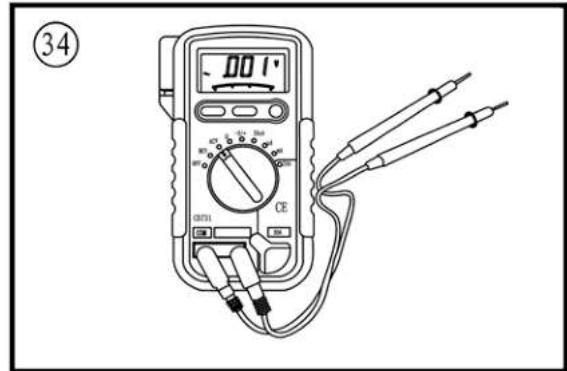

## GENERAL INFORMATION

---

### Magneto puller

Magneto drawing (**figure 36**) is special tool to dismantle magneto rotor . firstly put the mandril into the inside of shaft hole ,Turn the magneto rotor accordingly, screw magneto drawing and push-out magneto rotor

## ELECTRICAL SYSTEM FUNDAMENTALS

A thorough study of the many types of electrical systems used in today's motorcycles is beyond the scope of this manual. However, a basic understanding of electrical basics is necessary to perform simple diagnostic tests.

Refer to Electrical Testing in Chapter Two for typical test procedures and equipment. Refer to Chapter Ten for specific system test procedures.

### Voltage

Voltage is the electrical potential or pressure in an electrical circuit and is expressed in volts. The more pressure (voltage) in a circuit the more work can be performed.

Direct current (DC) voltage means the electricity flows in one direction. All circuits powered by a battery are DC circuits.

Alternating current (AC) means the electricity flows in one direction momentarily and then switches to the opposite direction. Alternator output is an example of AC voltage. This voltage must be changed or rectified to direct current to operate in a battery powered system.

### Resistance

Resistance is the opposition to the flow of electricity within a circuit or component and is measured in ohms. Resistance causes a reduction in available current and voltage

Resistance is measured in an inactive circuit with an ohmmeter. The ohmmeter sends a small amount of current into the circuit and measures how difficult it is to push the current through the circuit.

An ohmmeter, although useful, is not always a good indicator of a circuit's actual ability under operating conditions. This is because of the low voltage (6-9 volts) the meter uses to test the circuit. The voltage in an ignition coil secondary winding can be several thousand volts. Such high voltage can cause the coil to malfunction, even though it tests acceptable during a resistance test.

Resistance generally increases with temperature. Perform all testing with the component or circuit at room temperature. Resistance tests performed at high temperatures may indicate high resistance readings and cause unnecessary replacement of a component.

### Amperage

Amperage is the unit of measurement for the amount of current within a circuit. Current is the actual flow of electricity. The higher the current, the more work can be performed up to a given point. If the current flow exceeds the circuit or component capacity, it will damage the system.

## GENERAL INFORMATION

---

### **Warning**

If the current insulation damage, may cause short circuit fault which lead to short circuit or large current in components. It may cause a fire.

Thus, if the current of circuit or components measured by amperage exceeds the standard level, must check and repair electrical system at once.

## BASIC SERVICE METHODS

Most of the procedures in this manual are straightforward and can be performed by anyone reasonably competent with tools. However, consider personal capabilities carefully before attempting any operation involving major disassembly.

1. Front, in this manual, refers to the front of the UTV. The front of any component is the end closest to the front of the UTV. The left and right sides refer to the position of the parts as viewed by the rider sitting on the seat facing forward.
2. Whenever servicing an engine or suspension component, secure the UTV in a safe manner.
3. Tag all similar parts for location and mark all mating parts for position. Record the number and thickness of any shims when removing them. Identify parts by placing them in sealed and labeled plastic sandwich bags.
4. Tag disconnected wires and connectors with masking tape and a marking pen. Do not rely on memory alone.
5. Protect finished surfaces from physical damage or corrosion. Keep gasoline and other chemicals off painted surfaces.
6. Use penetrating oil on frozen or tight bolts. Avoid using heat where possible. Heat can warp, melt or affect the temper of parts. Heat also damages the finish of paint and plastics.
7. When a part is a press fit or requires a special tool to remove, the information or type of tool is identified in the text. Otherwise, if a part is difficult to remove or install, determine the cause before proceeding.
8. To prevent objects or debris from falling into the engine, cover all openings.
9. Read each procedure thoroughly and compare the illustrations to the actual components before starting the procedure. Perform the procedure in
10. Recommendations are occasionally made to refer service to a dealership or specialist. In these cases, the work can be performed more economically by the specialist than by the home mechanic.
11. The term replaces means to discard a defective part and replace it with a new part. Overhaul means to remove, disassemble, inspect, measure, repair and/or replace parts as required to recondition an assembly.
12. Some operations require using a hydraulic press. If a press is not available, have these operations performed by a shop equipped with the necessary equipment. Do not use makeshift equipment that may damage the motorcycle.
13. Repairs are much faster and easier if the UTV is clean before starting work. Degrease the motorcycle with a commercial degreaser; follow the directions on the container for the best results. Clean all parts with cleaning solvent when removing them.

## GENERAL INFORMATION

### CAUTION

**Do not direct high-pressure water at steering bearings, fuel hoses, wheel bearings, suspension and electrical components. Water may force grease out of the bearings and possibly damage the seals**

14. If special tools are required, have them available before starting the procedure. When special tools are required, they are described at the beginning of the procedure.
15. Make diagrams of similar-appearing parts. For instance, crankcase bolts are often not the same lengths. Do not rely on memory alone. Carefully laid out parts can become disturbed, making it difficult to reassemble the components correctly.
16. Make sure all shims and washers are reinstalled in the same location and position.
17. Whenever rotating parts contact a stationary part, look for a shim or washer.
18. Use new gaskets if there is any doubt about the condition of old ones.
19. If using self-locking fasteners, replace them with new ones. Do not install standard fasteners in place of self-locking ones.
20. Use grease to hold small parts in place if they tend to fall out during assembly. Do not apply grease to electrical or brake components.

### Removing Frozen Fasteners

If a fastener cannot be removed, several methods may be used to loosen it. First, apply a penetrating fluid. Apply it liberally and let it penetrate for 10-15 minutes. Rap the fastener several times with a small hammer. Do not hit it hard enough to cause damage. Reapply the penetrating fluid if necessary.

For frozen screws, apply penetrating fluid as described, then insert a screwdriver in the slot and rap the top of the screwdriver with a hammer. This loosens the rust so the screw can be removed in the normal way. If the screw head is too damaged to use this method, grip the head with locking pliers and twist the screw out.

Avoid applying heat unless specifically instructed. Heat may melt, warp or remove the temper from parts.

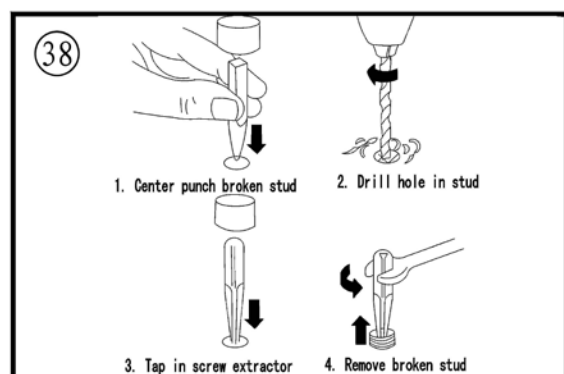
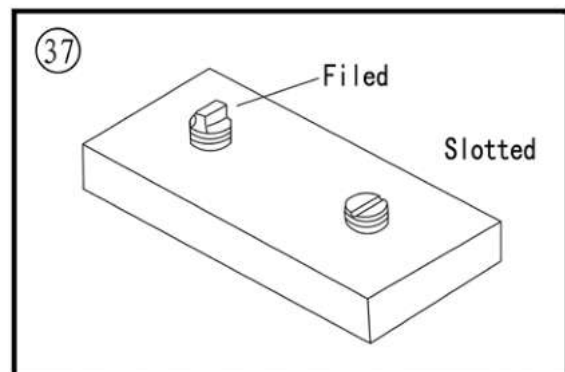

### Removing Broken Fasteners

If the head breaks off a screw or bolt, several methods are available for removing the remaining portion. If a large portion of the remainder projects out, try gripping it with locking pliers. If the projecting portion is too small, file it to fit a wrench or cut a slot in it to fit a screwdriver (**Figure 37**)

If the head breaks off flush, use a screw extractor. To do this, center punch the exact center of the



## GENERAL INFORMATION

remaining portion of the screw or bolt. Drill a small hole in the screw and tap the extractor into the hole. Back the screw out with a wrench on the extractor (**Figure 38**)

### Repairing Damaged Threads

Occasionally, threads are stripped through carelessness or impact damage. Often the threads can be repaired by running a tap (for internal threads on nuts) or die (for external threads on bolts) through the threads (**Figure 39**). To clean or repair spark plug threads, use a spark plug tap.

If an internal thread is damaged, it may be necessary to install a Helical or some other type of thread insert. Follow the manufacturer's instructions when installing their insert.

If it is necessary to drill and tap a hole, refer to **Table 8** for metric tap and drill sizes.

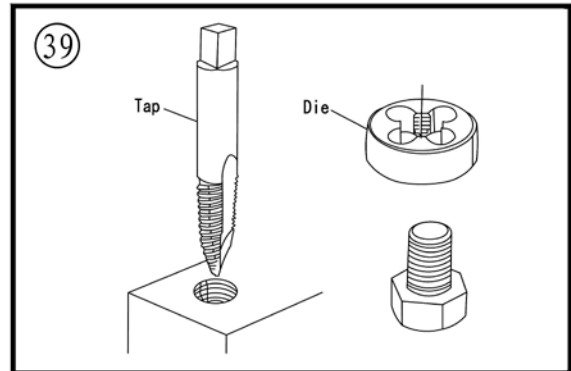

### Stud Removal/Installation

A stud removal tool (**Figure 40**) is available from most tool suppliers. This tool makes the removal and installation of studs easier. If one is not available, thread two nuts onto the stud and tighten them against each other. Remove the stud by turning the lower nut (**Figure 41**).

1. Measure the height of the stud above the surface.
2. Thread the stud removal tool onto the stud and tighten it, or thread two nuts onto the stud.
3. Remove the stud by turning the stud remover or the lower nut.
4. Remove any thread locking compound from the threaded hole. Clean the threads with an aerosol parts cleaner.
5. Install the stud removal tool onto the new stud or thread two nuts onto the stud.
6. Apply thread locking compound to the threads of the stud.
7. Install the stud and tighten with the stud removal tool or the top nut.
8. Install the stud to the height noted in Step 1 or its torque specification.
9. Remove the stud removal tool or the two nuts.

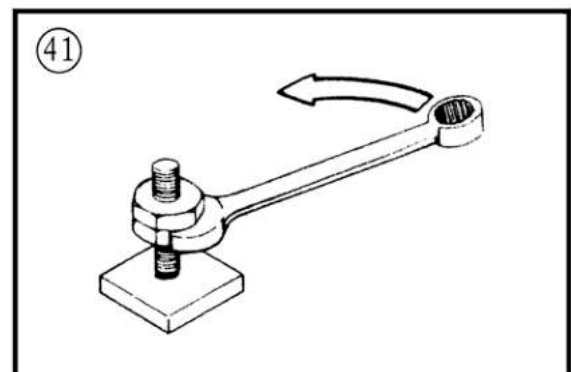
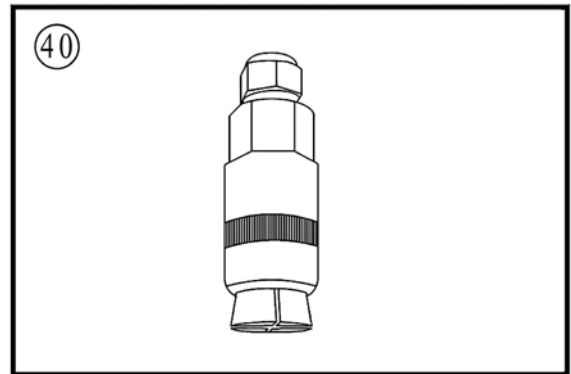

### Removing Hoses

When removing stubborn hoses, do not exert excessive force on the hose or fitting. Remove the

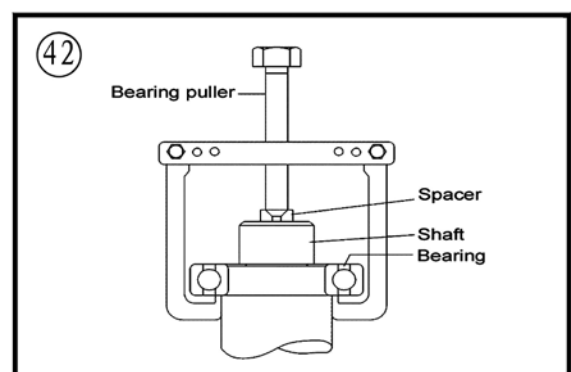

## GENERAL INFORMATION

hose, do not exert excessive force on the hose or fitting. Remove the hose clamp and carefully insert a small screwdriver or pick tool between the fitting and hose. Apply a spray lubricant under the hose and carefully twist the hose off the fitting. Clean the fitting of any corrosion or rubber hose material with a wire brush. Clean the inside of the hose thoroughly. Do not use any lubricant when installing the hose (new or old). The lubricant may allow the hose to come off the fitting, even with the clamp secure.

### Bearings

Bearings are used in the engine and transmission assembly to reduce power loss, heat and noise resulting from friction. Because bearings are precision parts, they must be maintained with proper lubrication and maintenance. If a bearing is damaged, replace it immediately. When installing a new bearing, take care to prevent damaging it.

Bearing replacement procedures are included in the individual chapters where applicable; however, use the following sections as a guideline.

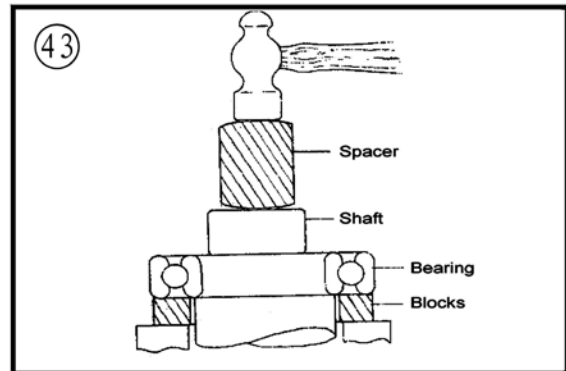

### NOTE

Unless otherwise specified, install bearings with the manufacturer's mark or number facing outward.

### Removal

While bearings are normally removed only when damaged, there may be times when it is necessary to remove a bearing that is in good condition. However, improper bearing removal will damage the bearing and possibly the shaft or case. Note the following when removing bearings:

1. When using a puller to remove a bearing from a shaft, take care that the shaft is not damaged. Always place a piece of metal between the end of the shaft and the puller screw. In addition, place the puller arms next to the inner bearing race. See **Figure 42**.
2. When using a hammer to remove a bearing from a shaft, do not strike the hammer directly against the shaft. Instead, use a brass or aluminum rod between the hammer and shaft (**Figure 43**) and make sure to support both bearing races with wooden blocks as shown.
3. The ideal method of bearing removal is with a hydraulic press. Note the following when using a press:
  - a. Always support the inner and outer bearing races with a suitable size wooden or aluminum spacer (**Figure 44**). If only the outer race is supported, pressure applied against the balls

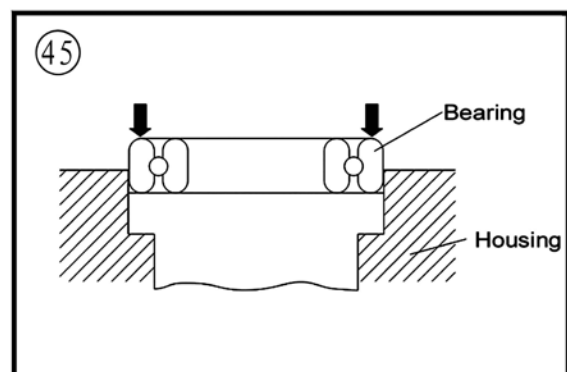
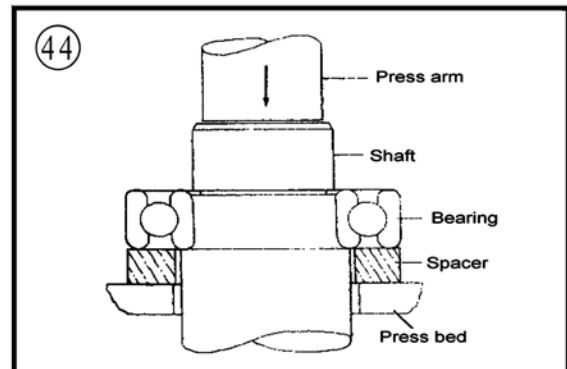

## GENERAL INFORMATION

- and/or the inner race will damage them.
- b. Always make sure the press arm (**Figure 44**) aligns with the center of the shaft. If the arm is not centered, it may damage the bearing and/or shaft.
  - c. The moment the shaft is free of the bearing. It drops to the floor. Secure or hold the shaft to prevent it from falling.

### Installation

1. When installing a bearing in a housing, apply pressure to the outer bearing race (**Figure 45**). When installing a bearing on a shaft, apply pressure to the inner bearing race (**Figure 46**).
2. When installing a bearing as described in Step 1, some type of driver is required. Never strike the bearing directly with a hammer or it will damage the bearing. When installing a bearing, use a piece of pipe or a driver with a diameter that matches the bearing inner race. **Figure 47** Shows the correct way to use a driver and hammer to install a bearing.
3. Step 1 describes how to install a bearing in a case half or over a shaft. However, when installing a bearing over a shaft and into the housing at the same time, a tight fit is required for both outer and inner bearing races. In this situation, install a spacer underneath the driver tool so that pressure is applied evenly across both races. See **Figure 48**. If the outer race is not supported as shown, the balls will push against the outer bearing race and damage it

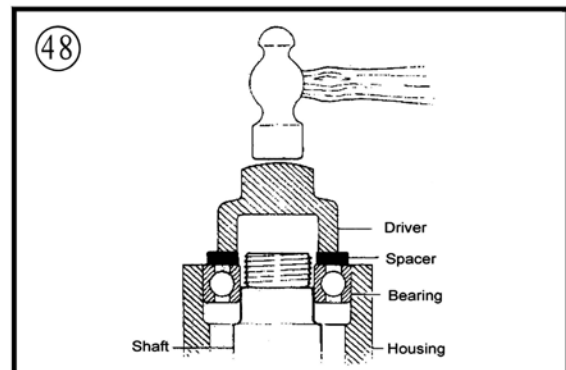
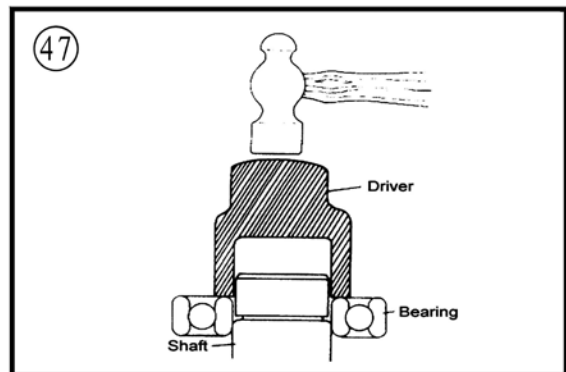
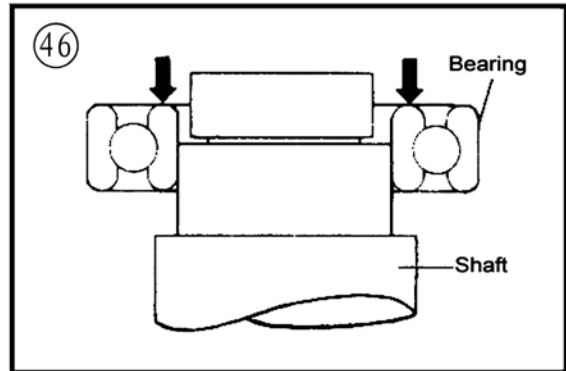

### Interference fit

1. Follow this procedure when installing a bearing over a shaft. When a tight fit is required, the bearing inside diameter is smaller than the shaft. In this case. Driving the bearing on the shaft using normal methods may cause bearing damage. Instead, heat the bearing before installation. Note the following:
  - a. Secure the shaft so it is ready for bearing installation.
  - b. Clean all residues from the bearing surface of the shaft. Remove burrs with a file or sandpaper.
  - c. Fill a suitable pot or beaker with clean mineral oil. Place a thermometer rated above 120°C(248°F) in the oil. Support the thermometer so it does not rest on the bottom or side of the pot.
  - d. Remove the bearing from its wrapper and secure it with a piece of heavy wire bent to hold it in the pot. Hang the bearing in the pot so it does not touch the bottom or sides of the pot.

## GENERAL INFORMATION

---

- e. Turn the heat on and monitor the thermometer. When the oil temperature rises to approximately 120°C(248°F), remove the bearing from the pot and quickly install it. If necessary, place a socket on the inner bearing race and tap the bearing into place. As the bearing chills, it will tighten on the shaft, so install it quickly. Make sure the bearing is installed completely.
2. Follow this step when installing a bearing in a housing. Bearings are general installed in a housing with a slight interference fit Driving the bearing into the housing using normal methods may damage the housing or cause bearing damage. Instead, heat the housing before the bearing is installed. Note the following:

### CAUTION

**Before heating the housing in this procedure, wash the housing thoroughly with detergent and water. Rinse and rewash the cases as required to remove all traces of oil and other chemical deposits**

- a. Heat the housing to approximately 100°C (212°F) in an oven or on a hot plate. An easy way to check that it is the proper temperature is to place tiny drops of water on the housing; if they sizzle and evaporate immediately, the temperature is correct. Heat only one housing at a time.

### CAUTION

**Do not heat the housing with a propane or acetylene torch. Never bring a flame into contact with the bearing or housing. The direct heat will destroy the case hardening of the bearing and will likely warp the housing.**

- b. Remove the housing from the oven or hot plate, and hold onto the housing with welding gloves. It is hot!

### NOTE

**Remove and install the bearings with a suitable size socket and extension.**

- c. Hold the housing with the bearing side down and tap the bearing out. Repeat for all bearings in the housing.
- d. Before heating the bearing housing, place the new bearing in a freezer if possible. Chilling a bearing slightly reduces its outside diameter while the heated bearing housing assembly is slightly larger due to heat expansion. This makes bearing installation easier.

### NOTE

**Always install bearings with the manufacturer's mark or number facing outward.**

- e. While the housing is still hot. Install the new bearing(s) into the housing. Install the bearings by hand. if possible. If necessary, lightly tap the bearing(s) into the housing with a driver placed on the outer bearing race (**Figure 45**). Do not install new bearings by driving on the inner-bearing race. Install the bearing(s) until it seats completely.

## GENERAL INFORMATION

### Seal Replacement

Seals (**Figure 49**) contain oil, water, grease or combustion gasses in a housing or shaft. Improperly removing a seal can damage the housing or shaft. Improperly installing the seal can damage the seat. Note the following:

1. Prying is generally the easiest and most effective method of removing a seal from the housing. However, Always place a rag underneath the pry tool to prevent damage to the housing. Note the seal's installed depth or if it is installed flush.
2. Pack waterproof grease in the seal lips before the seal is installed.
3. In most cases, install seals with the manufacturer's numbers or marks facing out.
4. Install seals with a socket or driver placed on the outside of the seal as shown in. Drive the seal squarely into the housing until it is to the correct depth or flush as noted during removal. Never install a seal by hitting against the top of it with a hammer.

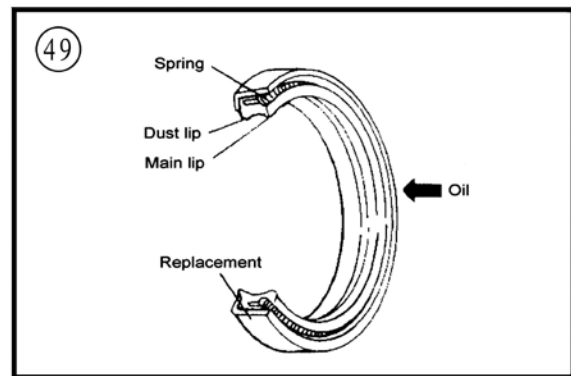

## STORAGE

Several months of non-use can cause a general deterioration of the motorcycle, UTV This is especially true in areas of extreme temperature variations. This deterioration can be minimized with careful preparation for storage. A properly stored motorcycle is much easier to return to service.

### Storage Area Selection

When selecting a storage area, consider the following:

1. The storage area must be dry. A heated area is best, but not necessary. It should be insulated to minimize extreme temperature variations.
2. If the building has large window areas, mask them to keep sunlight off the UTV .
3. Avoid buildings in industrial areas where corrosive emissions may be present. Avoid areas close to saltwater.
4. Consider the area's risk of fire, theft or vandalism. Check with an insurer regarding UTV coverage while in storage.

### Preparing the Motorcycle for Storage

The amount of preparation a motorcycle should undergo before storage depends on the expected length of non-use, storage area conditions and personal preference. Consider the following list the minimum requirement:

1. Wash the UTV thoroughly. Make sure all dirt, mud and other debris are removed.
2. Lubricate the drive chain.
3. Start the engine and allow it to reach operating temperature. Drain the engine oil regardless of the riding time since the last service. Fill the engine with the recommended type of oil.
4. Drain the fuel tank fuel lines throttle.
5. Remove the spark plug and ground the ignition system with a grounding tool as described in this chapter. Then pour a teaspoon (15-20ml) of engine oil into the cylinder. Place a rag over the opening and Start the engine over to distribute the oil. Remove the grounding tool and reinstall the spark plug.

## GENERAL INFORMATION

6. When the engine has cooled to room temperature, drain the cooling system drain the coolant in the coolant reserve tank and all tank lines.
7. Cover the exhaust and intake opening.
8. Apply a protective substance to the plastic and rubber components. Make sure to follow the manufacturer's instructions for each type of product being used.
9. Place the UTV on a work stand with both wheels off the ground.
10. Cover the UTV with old bed sheets or something similar. Do not cover it with any plastic material that will trap moisture.

### Returning the UTV to Service

The amount of service required when returning a UTV to service after storage depends on the length of non-use and storage conditions. In addition to performing the reverse of the procedure, note the following:

1. Remove the covers from the intake and exhaust openings.
2. Service the air filter as described in Chapter Three.
3. Inspect the cooling system. Check the drain plug and hose connections for leaks.
4. Refill the fuel tank. Turn the fuel shutoff valve on and check for fuel leaks.
5. Make sure the brakes, clutch, throttle and engine stop switch work properly before operating the UTV. Evaluate the service intervals to determine which areas require service.
6. If the UTV has been in storage for longer than four months, change the engine oil as and filter, and the transmission oil as described

## TROUBLESHOOTING

Diagnose electrical and mechanical problems by following an orderly procedure and remembering the basic operating requirements

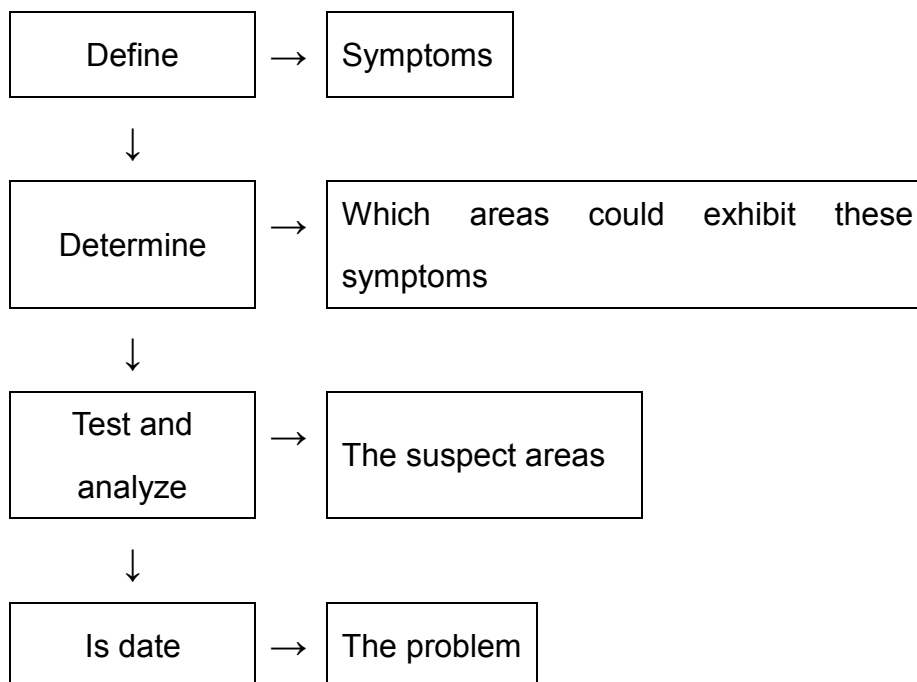

By following a systematic approach, the possibility of unnecessary parts replacement can be avoided, always start with the simple and most obvious checks when troubleshooting, This would include

## GENERAL INFORMATION

---

the engine stop switch, fuel quantity and condition, fuel valve position and spark plug cap tightness

Proper maintenance as described in Chapter Three reduces the necessity for troubleshooting. Even with the best of care, however, the motorcycle may develop problems that require troubleshooting.

If the problem cannot be solved. Stop and evaluate all conditions prior to the problem. If the motorcycle must be taken to a repair facility, the mechanic will want to know as many details as possible.

For removal, installation and test procedures for some components, refer to the specific chapter. When applicable, tables at the end of each chapter also provide specifications and service limits.

## ENGINE PRINCIPLES AND OPERATING REQUIREMENTS

An engine needs three basics to run properly:

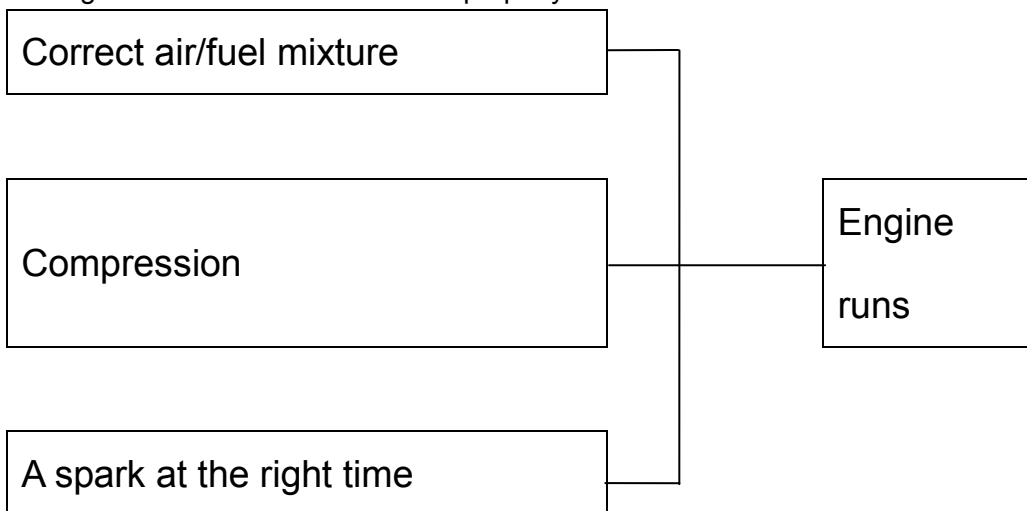

If one basic requirement is missing the engine will not run.

## STARTING THE ENGINE

When experiencing engine-starting troubles, it is easy to work out of sequence and forget basic starting procedures. The following sections describe the recommended starting procedures.

Several special faults and countermeasures of EFI engine system

### 1. Special fault:

Idle speed is too high at starting moment.

The engine starts normally, the engine speed will be a little higher than normal idle speed (1400rpm) within the first 10 seconds. According to different temperature of engine coolant, the process will continue from several seconds to tens of seconds.

Finally, the engine speed will decrease to normal idle speed automatically.

Reason: The intelligent control function of EFI automatically forces to complete the engine warm-up process and enhance the oil pressure to correct level at the same time.

Result: Ensure the engine can work with steady idle speed and conducive to complete the engine warm-up process quickly after start engine in low temperature.

## GENERAL INFORMATION

---

### 2.Special fault:

Idle instability, CH and CO of off-gas out of limits

Reason: Oxygen sensor loosing cause slight leakage or pipe slight leakage and makes the oxygen sensor collect too much oxygen ion signal. The wrong signal transmits to the ECU which result the increasing of oil supply. Finally, it causes the oil too thick.

### 3.Special fault:

In the vehicle driving process, there is no idle speed or too low idle speed when restart it after storage battery power off abnormally.

Countermeasure: Step on the throttle slightly when start the engine and maintain for a few seconds. And then let go of the throttle, remove the key and switch off the vehicle. After waiting for ten minutes, switch on with the key that could restart the engine.

### 4.Special fault:

The engine can't start normally after changing air filter or air throttle

Reason: The inner cleanness of old air filter and air throttle is poor after long running. The idle speed step motor will revise the volume of air up automatically. If change to new air filter or air throttle, idle speed step motor inside ECU need to match the volume of oil when in idle speed automatically.

Countermeasure: When start the engine, run 2 to 3 minutes in idle speed. If it can't run normally in idle, turn off the engine and restart it repeatedly 10 seconds later until it can run normally in idle. Or switch on and off the key 5 times in a row which can reset all saved data in ECU.

## Engine is cold

1. Shift the transmission into neutral.
2. Turn the fuel valve on or confirm if the fuel is in upper or below retile in the fuel tank.
3. Start the engine and run in neutral for 1 minute to enhance the temperature of engine. If it runs normally in neutral, you can drive the UTV.

### NOTE

**Race the engine with high power in low temperature will cause damage to the engine.**

## Engine is warm

1. Shift the transmission into neutral.
2. Confirm if the fuel is in upper or below retied in the tank.
3. Start the engine. If the engine can run in idle speed steady and the engine speed is lower than 1600RPM, the UTV can shift driving forward.

### NOTE

Shift operation must be after UTV has stopped and the engine speed has reduced to idle speed (1450RPM).

## Flooded engine

If the engine fails to start after several attempts, it is probably flooded. This occurs when too much fuel is drawn into the engine and the spark plug fails to ignite it. The smell of gasoline is often evident



## GENERAL INFORMATION

---

when the engine is flooded. Troubleshoot a flooded engine as follows:

1. Open the throttle fully and hold in this position. Then start the engine firmly through its entire stroke ten times to clear the engine. Close the throttle.
2. Check and repair ignition system.
3. If the engine still does not start, refer to Engine will Not Start this chapter.

## ENGINE WILL NOT START

### Identifying the Problem

If the engine does not start, perform the following steps in order while remembering the Engine Principals and Operating Requirements described in this chapter. If the engine fails to start after performing these checks, refer to the troubleshooting procedures indicated in the steps. If the engine starts, but idles or runs roughly, refer to Poor Engine Performance in this chapter.

1. Refer to Starting the Engine in this chapter to make sure all starting procedures are correct.
2. If the engine seems flooded, refer to Starting The Engine in this chapter. If the engine is not flooded, continue with Step 3.
3. Remove the cap from the fuel tank and make sure the fuel tank and make sure the fuel tank has a sufficient amount of fuel to start the engine.
4. If there is sufficient fuel in the fuel tank, remove the spark plug immediately after attempting to start the engine. The plug's insulator should be wet, indicating that fuel is reaching the engine. If the plug tip is dry, fuel is not reaching the engine. Refer to Fuel System in this chapter. If there is fuel on the spark plug and the engine will not start, the engine may not have adequate spark. Continue with Step 5.
5. Make sure the direct ignition coil or spark plug wire is secure. Push the direct ignition coil or spark plug cap and slightly rotate it to clean the electrical connection between the plug and the connector. If the engine does not start. Continue with step 6

#### **NOTE**

**A cracked or damaged direct ignition coil or spark plug cap and cable can cause intermittent problems that are difficult to diagnose. If the engine occasionally misfires or cuts out, use a spray bottle to wet the direct ignition coil or plug cap and plug cable while the engine is running. Water that enters one of these areas causes an arc through the insulating material, causing an engine misfire.**

#### **NOTE**

**Engine misfire can also be caused by water that enters through connectors. Check the connectors for loose wire ends. On waterproof connectors, check for damage where the wires enter the connector.**

## GENERAL INFORMATION

---

6. Perform the Spark Test in this section. If there is a strong spark, perform Step 7. If there is no spark or if the spark is very weak, refer to Ignition System Testing in Chapter Ten.
7. If the fuel and ignition systems are working correctly, perform a leak down test (this chapter) and cylinder compression test. If the leak down test indicates a problem, or the compression under Engine in this chapter.

### Spark Test

Perform a spark test to determine if the ignition system is producing adequate spark. This test should be performed with a spark tester. A spark tester looks like a spark plug with an adjustable gap between the center electrode and grounded base. Because the voltage required to jump the spark tester gap is sufficiently larger than that of a normally gapped spark plug, the test results are more accurate than with a spark plug. Do not assume that because a spark jumped across a spark plug gap, the ignition system is working correctly.

Perform this test on the engine when it is both cold and hot, if possible. If the test results are positive for each test, the ignition system is working correctly.

#### CAUTION

**After removing the direct ignition coil or spark plug cap and before removing the spark plug in Step 1, clean the area around the spark plug with compressed air. Dirt that falls into the cylinder causes rapid engine wear.**

1. Disconnect the direct ignition coil or spark plug cap. Check for the presence of water.
2. Visually inspect the spark plug for damage.
3. Connect a spark tester to the direct ignition coil or spark plug cap. Ground the spark tester base (or spark plug) to a good ground. Position the spark tester or spark plug firing tip away from the open spark plug hole. Position the spark tester so the electrodes are visible.

#### WARNING

***Mount the spark tester or spark plug away from the spark plug hole in the cylinder. If the engine is flooded, do not perform this test. The spark tester can ignite fuel ejected through the spark plug hole.***

4. Shift the transmission into neutral.

#### WARNING

***Do not hold the spark tester, spark plug or connector or a serious electrical shock may result.***

5. Turn the engine over using the starter and push the starter button. A fat blue spark must be evident between the spark tester or spark plug terminals.
6. If there is a strong, blue spark, the ignition system is functioning properly, Check for one or more of the following possible malfunctions:
  - a. Faulty fuel system component.
  - b. Flooded engine.

## GENERAL INFORMATION

---

- c. engine damage(low compression).
- 7. If the spark was weak (white or yellow) or if there was no spark, perform the peak voltage checks described under Ignition System Testing.
- 8. Reinstall the fuel tank.

### The Starter Cannot Work Repeatedly Or Can Only Work Slowly

Refer to Starting System Testing

## POOR ENGINE PERFORMANCE

If the engine runs, but performance is unsatisfactory, refer to the following section that best describes the symptoms.

### The Engine Starts Slowly Or Difficultly

Check for the following:

- 1. Incorrect choke operation. This can be due to improper use or a stuck choke valve in the throttle.
- 2. Incorrect hot start valve operation. This situation can be due to improper use or incorrect hot start valve adjustment.
- 3. The fuel tank connection hose is clogged.
- 4. The fuel hose is clogged or the oil filter is clogged.
- 5. The injector is clogged.

#### **NOTE**

**If a warm or hot engine will start with the choke on, or if a cold engine starts and runs until the choke is turned off. The pilot jet is probably plugged.**

- 8. Contaminated or stale fuel.
- 9. Clogged air filter.
- 10. Intake pipe air leak.
- 11. Plugged exhaust system. Check the silencer or muffler, especially if the utility terrain vehicle was just returned from storage.
- 12. Faulty ignition system component.

### Engine Backfires, Cuts Out or Misfires During Acceleration

A backfire occurs when fuel is burned or ignited in the exhaust system.

- 1. A lean air/fuel mixture can cause these engine performance problems. Check for the following conditions:
  - a. Incorrect float level adjustment.
  - b. Plugged pilot jet or pilot system.
- 2. Faulty accelerator pump.
- 3. Loose exhaust pipe-to-cylinder head connection.
- 4. Intake air leak.

## **GENERAL INFORMATION**

---

5. Incorrect ignition timing or a damaged ignition system can cause these conditions. Perform the Peak Voltage Tests to isolate the damaged ignition system component. Check the ignition timing as described.

### **NOTE**

**The ignition timing is controlled by the ICM and cannot be adjusted. However, checking the ignition timing can be used to diagnose problems.**

6. Check the following engine components:
  - a. Broken valve springs.
  - b. Stuck or leaking valves.
  - c. Worn or damaged camshaft lobes.
  - d. Incorrect valve timing due to incorrect camshaft installation or a mechanical failure.

### **The Engine Is Not Idling Or Cannot Idle Stably**

If the engine backfires when the throttle is released, check the following:

1. Lean throttle pilot system.
2. Loose exhaust pipe-to-cylinder head connection.
3. Faulty ignition system component.
4. Check the following engine components:
  - a. Broken valve springs.
  - b. Stuck or leaking valves.
  - c. Worn or damaged camshaft lobes.
  - d. Incorrect valve timing due to incorrect camshaft installation or a mechanical failure.

### **Poor Fuel Mileage**

1. Clogged fuel system.
2. Dirty or clogged air filter.
3. Incorrect ignition timing.

### **Engine Will Not Idle or Idles Roughly**

1. Clogged air filter element.
2. Poor fuel filter or fuel hose.
3. Faulty accelerator pump assembly.
4. Contaminated or stale fuel.
5. ECU is not working properly, according to the 33 page "5 special treatment failure".
6. Leaking head gasket.
7. Intake air leak.
8. Incorrect ignition timing
9. Low engine compression

### **Low Engine Power**

1. Support the UTV in a stand with the rear wheel off the ground. then spins freely. If the wheel does

## GENERAL INFORMATION

---

not spin freely. Check for the following conditions:

- a. Dragging brakes. Check for this condition immediately after riding the UTV

### **NOTE**

**After riding the UTV. Come to a stop on a level surface. Turn the engine off and shift the transmission into neutral. Walk or push the UTV forward. If the UTV is harder to push than normal. Check for dragging brakes**

- b. Damaged or binding drive system
  - c. Damaged drive system and gear bearing
2. Test ride the UTV and accelerate quickly from first to second gear. If the engine speed in-creased according to throttle position. Perform **Step 3**. If the engine speed did not increase. Check CVT
    - a. Warped clutch plates/discs
    - b. CVT spring
  3. Test rides the UTV and accelerate lightly. If the engine speed increased according to throttle position. Perform Step 4. If the engine speed did not increase. Check for one or more of the following problems:
    - a. Clogged air filter
    - b. Restricted fuel flow
    - c. Pinched fuel tank breather hose (Figure 9).
    - d. Clogged or damaged silencer or muffler

### **NOTE**

**A clogged exhaust system will prevent some of the burned exhaust gasses from exiting the exhaust port at the end of the exhaust stroke. This condition effects the incoming air/fuel mixture on the intake stroke and reduces engine power**

4. Check for retarded ignition timing. A decrease in power results when the plugs fire later than normal
5. Check for one or more of the following problems
  - a. Low engine compression
  - b. Worn spark plug
  - c. Fouled spark plug
  - d. Incorrect spark plug heat range
  - e. Weak ignition coil
  - f. Incorrect ignition timing
  - g. Plugged throttle passages
  - h. Incorrect oil level (too high or too low)
  - i. Contaminated oil
  - j. Worn or damaged valve train assembly
  - k. Engine overheating
6. If the engine knocks when it is accelerated or when running at high speed. Check for one or more of the following possible malfunctions:
  - a. Incorrect type of fuel

## GENERAL INFORMATION

---

- b. Lean fuel mixture
- c. Advanced ignition timing

### NOTE

**Other signs of advanced ignition timing are engine overheating and hard or uneven engine starting**

- d. Excessive carbon buildup in combustion chamber
- e. Worn pistons and/or cylinder bores

### Poor Idle or Low Speed Performance

1. Check for an incorrect pilot screw adjustment
2. Check for damaged or loose intake pipe and air filter housing hose clamps. These conditions will cause an air leak
3. Perform the spark test in this chapter. Note the following:
  - a. If the spark is good. Go to Step 4
  - b. If the spark is weak. *Perform the Peak Voltage Testing*
4. Check the ignition timing. If ignition timing is correct. Perform Step 5. If the timing is incorrect. Perform the *Peak Voltage Testing*
5. Check the fuel system as described in this chapter

### Poor High Speed Performance

1. Check ignition timing. If the ignition timing is correct. Perform Step 2. If the timing is incorrect. Perform the *Peak Voltage*
2. Check the fuel system as described in this chapter
3. Check the valve clearance as described. Note the following:
  - a. If the valve clearance as correct. Perform Step 4
  - b. If the clearance is incorrect. adjust the valves clearance as described in Chapter Three
4. Incorrect valve timing and worn or damaged valve springs can cause poor high-speed performance. If the camshaft was timed just before the UTV experiencing this type of problem. The cam timing may be incorrect. If the cam timing was not set or changed. And all the other inspection procedures in this section failed to locate the problem. Inspect the camshaft and valves assembly

## FUEL SYSTEM

The following section isolates common fuel system problems under specific complaints. If there is a good spark. Poor fuel flow may be preventing the correct amount of fuel from being supplied to the spark plug. Troubleshoot the fuel system as follows:

1. Clogged fuel tank breather hose
2. Check that there is a sufficient amount of fuel in the tank
3. Start the engine after the following examination. Remove the spark plug, see if there is fuel on the

## GENERAL INFORMATION

---

end of it.

Note the following:

- a. If there is no visible fuel on the end of the spark plug, go to check whether the fuel valve, oil injector or fuel hose is clogged.
- b. If the spark plug at the bottom of a fuel. And the engine has spark. Check for an excessive intake air leak or the possibility of contaminated or stale fuel.

### **NOTE**

**If the UTV was not used for some time. And was not properly stored. The fuel may have gone stale. Where lighter parts of the fuel have evaporated. Depending on the condition of the fuel. a no-start condition can result**

- c. If there is too much fuel on the end of the spark plug, go to check whether there is overflow at the air filter or the ducting damper.

### **Rich Mixture**

The following conditions can cause a rich air/fuel mixture:

1. Air pressure sensor, oxygen sensor, solar term door position sensor fault
2. ECU program error or damage

### **Lean Mixture**

The following conditions can cause a lean air/fuel mixture:

1. The injector is clogged
2. The pump pressure is not enough
3. ECU program chaos
4. ECU damage
5. The pressure sensor, oxygen sensor, solar term door position sensor fault

## ENGINE

### **Engine Smoke**

The color of engine smoke can help diagnose engine problems or operating conditions

### **Black smoke**

Black smoke is an indication of a rich air/fuel mixture

### **Blue smoke**

## GENERAL INFORMATION

---

Blue smoke indicates that the engine is burning oil in the combustion chamber as it leaks past worn valve stem seals and piston rings. Excessive oil consumption is another indicator of an engine that is burning oil. Perform a compression test to isolate the problem.

### White smoke or steam

It is normal to see white smoke or steam from the exhaust after first starting the engine in cold weather. This is actually condensed steam formed by the engine during combustion. If the UTV is ridden far enough, the water cannot collect in the crankcase and should not become a problem. Once the engine heats up to normal operating temperature, the water evaporates and exits the engine through the crankcase vent system. However, if the UTV is ridden for short trips or repeatedly started and stopped and allowed to cool off without the engine getting warm enough, water will start to collect in the crankcase. With each short run of the engine, more water collects. As this water mixes with the oil in the crankcase, sludge is produced. Sludge can eventually cause engine damage as it circulates through the lubrication system and blocks off oil passages.

Large amounts of steam can also be caused by a cracked cylinder head or cylinder block surface that allows coolant to leak into the combustion chamber. Perform a Coolant System Pressure Test.

### Low Engine Compression

Problems with the engine top end will affect engine performance. When the engine is suspect, perform the leak down procedure in this chapter and make a compression test. Interpret the results as described in each procedure to troubleshoot the suspect area. An engine can lose compression through the following areas:

1. Valves:
  - a. The gap between the valve is not suitable.
  - b. Incorrect valve timing.
  - c. Worn or damaged valve seat surfaces.
  - d. Bent valves.
  - e. Weak or broken valve springs.
2. Cylinder head:
  - a. Loose spark plug or damaged spark plug hole.
  - b. Damaged cylinder head gasket.
  - c. Warped or cracked cylinder head.
3. The pressure relief system is damaged.

### High Engine Compression

1. The pressure relief system malfunction.
2. Excessive carbon buildup in the combustion chamber.

### Engine Overheating

#### (Cooling System)



## GENERAL INFORMATION

---

### **WARNING**

*Do not remove the radiator cap, coolant drain plug or disconnect any coolant hose immediately after or during engine operation. Scalding fluid and steam may be blown out under pressure and cause serious injury. When the engine has been operated, the coolant is very hot and under pressure. Attempting to remove the items when the engine is hot can cause the coolant to spray violently from the radiator, water pump or hose, causing severe burns and injury.*

1. Low coolant level.
2. Air in cooling system.
3. Clogged radiator, hose or engine coolant passages.
4. Worn or damaged radiator cap.
5. Damaged water pump.

### **Engine Overheating**

#### **(Engine)**

1. Improper spark plug heat range.
2. Low oil level.
3. Oil not circulating properly.
4. Valves leaking.
5. Heavy carbon deposits in the combustion chamber.
6. Dragging brake(s).
7. Slipping clutch.

### **The Ignition Advance Angle Is Too Large**

Preignition is the premature burning of fuel and is caused by hot spots in the combustion chamber. Glowing deposits in the combustion chamber, inadequate Cooling or an overheated spark plug can all cause preignition. This is first noticed as a power loss but eventually causes damage to the internal parts of the engine because of the high combustion chamber temperature.

### **Detonation**

Detonation is the violent explosion of fuel in the combustion chamber before the proper time of ignition. Using low octane gasoline is a common cause of detonation.

Even when using a high octane gasoline, detonation can still occur. Other causes are over-advanced ignition timing, lean air/fuel mixture at or near full throttle, inadequate engine cooling, or the excessive accumulation of carbon deposits in the combustion chamber.

Continued detonation can result in engine damage.

### **Power Loss**

Refer to Poor Engine Performance in this chapter.

## GENERAL INFORMATION

---

### Engine Noises

Unusual noises are often the first indication of a developing problem. Investigate any new noises as soon as possible. Something that may be a minor problem, if corrected, could prevent the possibility of more extensive damage.

Use a mechanic's stethoscope or a small section of hose held near your ear (not directly on your ear) with the other end close to the source of the noise to isolate the location. Determining the exact cause of a noise can be difficult. If this is the case, consult with a professional mechanic to determine the cause. Do not disassemble major components until all other possibilities have been eliminated.

Consider the following when troubleshooting engine noises:

1. Knocking or pinging during acceleration can be caused by using a lower octane fuel than recommended. May also be caused by poor fuel. Pinging can also be caused by an incorrect spark plug heat range or carbon buildup in the combustion chamber.
2. Slapping or rattling noises at low speed or during acceleration—May be caused by excessive piston-to-cylinder wall clearance (piston slap).

#### **NOTE**

**Piston slap is easier to detect when the engine is cold and before the piston has expanded. Once the engine has warmed up, piston expansion reduces piston-to-cylinder clearance.**

3. Knocking or rapping while decelerating—Usually caused by excessive rod bearing clearance.
4. Persistent knocking and vibration occurring every crankshaft rotation—Usually caused by worn rod or main bearing(s). Can also be caused by broken piston rings or a damaged piston pin.
5. Rapid on-off squeal—Compression leak around cylinder head gasket or spark plug(s).
6. Valve train noise—Check for the following:
  - a. Excessive valve clearance.
  - b. Worn or damaged camshaft.
  - c. Damaged camshaft.
  - d. Worn or damaged valve train components.
  - e. The valve hose hole is damaged
  - f. The valve sticks on the hose
  - g. Broken valve spring.
  - h. Low oil pressure.
  - i. Clogged cylinder oil hole or oil passage.

### ENGLNE LUBRICATION

Mis-operation of the engine lubrication system will cause the engine scrap. Check the lubrication oil level and pressure of the engine.

## GENERAL INFORMATION

---

### High Oil Consumption or Excessive

#### Exhaust Smoke

1. Worn valve guides.
2. Worn valve guide seals.
3. Worn or damaged piston rings.
4. Incorrect piston ring installation.

#### Low Oil Pressure

1. Low oil level.
2. Worn or damaged oil pump.
3. Clogged oil strainer screen.
4. Clogged oil filter.
5. Internal oil leakage.
6. Oil relief valve stuck open.
7. Incorrect type of engine oil.

#### High Oil Pressure

1. The lubrication oil pressure valve is stuck and closed.
2. Clogged oil filter.
3. Clogged oil gallery or metering orifices.

#### No Oil Pressure

1. Low oil level.
2. The lubrication oil pressure valve is stuck and closed.
3. Damaged oil pump.
4. Incorrect oil pump installation.
5. Internal oil leak.

#### Oil Level Too Low

1. The lubrication oil does not keep at the normal level.
2. Worn piston rings.
3. Worn cylinder.
4. Worn valve guides.
5. Worn valve guide seals.
6. Piston rings incorrectly installed during engine overhaul.
7. External oil leakage.
8. Oil leaking into the cooling system.

## GENERAL INFORMATION

---

### Oil Contamination

1. Blown head gasket allowing coolant to leak into the engine.
2. Coolant leak.
3. Oil and filter not changed at specified intervals or when operating conditions demand more frequent changes.

### CYLINDER LEAK DOWN TEST

A cylinder leak down test can accurately pinpoint engine leakage problems from the head gasket, water jackets in the cylinder head and cylinder, valves and valve seats, and piston rings. This test is performed by applying compressed air to the cylinder through a special tester and then measuring the percent of leakage. A cylinder leak down tester and an air compressor are needed to perform this test.

When performing a leak down test, the engine is first set at TDC on its compression stroke so that all the valves are closed. When the combustion chamber is pressurized, very little air should escape. However, the difficulty in performing a leak down test on a single cylinder engine (especially on the engines described in this manual with low static engine compression) is in preventing the piston from moving as the combustion chamber starts to pressurize. Any piston movement will force the crankshaft to turn away from TDC and allow air to escape past an open valve seat.

In this procedure it will be necessary to lock the engine at TDC on its compression stroke and then perform the leak down test. Follow the manufacturer's directions along with the following information when performing a cylinder leak down test.

1. Support the UTV on a work stand with the rear wheel off the ground.
2. Remove the air filter assembly. Open and secure the throttle so it is at its wide-open position.
3. Remove the spark plug.
4. Install the threaded hose adapter from the leak down kit. Then install the leak down gauge onto the hose.
5. Remove the ignition timing hole cap from the left crankcase cover.
6. Remove the crankshaft hole cap from the right crankcase cover.

#### **NOTE**

**Because the following test is performed with the cylinder head cover installed on the engine, the camshaft lobes cannot be viewed to ensure that the engine is positioned at TDC on its compression stroke. To determine when the engine is approaching TDC on its compression stroke, or whether it is 360° off. Observe the following two indicators to predict engine position. First, when aligning the index marks in Step 7, listen for pressure building inside the combustion chamber. Indicating that the piston is moving to TDC on its compression stroke. Second, view the gauge on the leak down tester when turning the engine. As the piston moves toward TDC on its compression stroke, compression building inside the combustion chamber may**

## GENERAL INFORMATION

---

cause the gauge needle to move slightly. If the crankshaft is 360° off, these indicators will not be present.

### **NOTE**

The decompress or mechanism will click loudly once during each crankshaft revolution. This is normal.

7. Use hex socket on the primary drive gear mounting bolt and turn the crankshaft clockwise and align the TDC mark on the flywheel with the index mark on the left crankcase cover Remove the hex socket from the primary drive gear.
8. Perform the following to lock the transmission so the engine remains at TDC on its compression stroke when performing the leak down test:

### **WARNING**

*Do not attempt to lock the engine by trying to use a tool to hold the Allen bolt on the end of the crankshaft. Once the combustion chamber becomes pressurized, any crankshaft movement can throw the tool away from the engine under considerable force, attempting to hole the tool can cause serious injury. Engine damage may also occur to the crankshaft or right crankcase cover. Lock the engine as described in this procedure.*

- a. Turn the drive sprocket by hand and shift the transmission into top gear with the shift pedal.
  - b. Mount a holding tool or equivalent onto the drive sprocket. Use a wooden block and clamp to hold the holding tool so it cannot move when the combustion chamber becomes pressurized.
  - c. Check that the TDC marks are still aligned as described in Step7,  
If not, turn the crankshaft as required, then relock the holding tool in position.
9. Remove the radiator cap and the oil filler cap.
  10. Perform a cylinder leak down test by applying air pressure to the combustion chamber. Follow the manufacturer's instructions while reading the percent of leakage on the gauge. Listen for air leaking while noting the following:

### **NOTE**

Because of play in the transmission gears, it is unlikely the engine will stay at TDC on the first try If the crankshaft turns, reposition the countershaft slightly and then relock it in position with the holding tool. After several attempts, you will get a feel of the transmission play and know what direction the countershaft should be turned and locked.

### **NOTE**

If a large amount of air escapes from the exhaust pipe or through the throttle, the air is leaking through on open valve, Check the index mark to make sure the engine is at TDC on the compression stroke, If the engine is remaining

## **GENERAL INFORMATION**

---

**at TDC but there is still a large amount of air escaping from the engine, the crankshaft is off one revolution. Turn the engine 360° and realign the TDC mark as described in Step 7, then relock it as described in Step 8.**

- a. Air leaking through the exhaust pipe indicates a leaking exhaust valve.
  - b. Air leaking through the throttle indicates a leaking intake valve.
  - c. Air leaking through both the intake and exhaust valves indicates the engine is not set at TDC on its compression stroke.
  - d. Air leaking through the coolant filler neck indicates a leaking cylinder head gasket or a cracked cylinder head or cylinder liner.
  - e. Air leaking through the oil filler hole indicates the rings are not sealing properly in the bore.
11. If the cylinder leak down is 10 percent or higher, further service is required.
  12. Disconnect the test equipment and install all the parts previously removed.

## **ELECTRICAL TESTING**

This section describes basic electrical testing and test equipment use.

### **Preliminary Checks and Precautions**

Refer to the color wiring diagrams at the end of the manual for component and connector identification; Use the wiring diagrams to determine how the circuit should work by tracing the current paths from the power source through the circuit components to ground. Also, check any circuits that share the same fuse (if used), ground or switch. If the other circuits work properly and the shared wiring is good, the cause must be in the wiring used only by the suspect circuit. If all related circuits are faulty at the same time, the probable cause is a poor ground connection or a blown fuse (if used).

As with all troubleshooting procedures, analyze typical symptoms in a systematic manner. Never assume any thing and do not overlook the obvious like a blown fuse or an electrical connector that has separated. Test the simplest and most obvious items first and try to make tests at easily accessible points on the UTV.

Before starting any electrical troubleshooting, perform the following:

1. Check the fuse if the fuse is blown, replace it.
2. Inspect the battery. Make sure it is fully charged, and the battery leads are clean and securely attached to the battery terminals.
3. Disconnect each electrical connector in the suspect circuit and make sure there are no bent terminals in the electrical connector
4. Make sure the terminals on the end of each wire are pushed all the way into the connector. If not. Carefully push them in with a narrow blade screwdriver
5. Check the wires where they connect to the terminals for damage
6. Make sure all terminals within the connector are clean and free of corrosion. Clean them. If necessary. And pack the connectors with dielectric grease
7. Push the connectors with dielectric grease. The connectors are fully engaged and locked together
8. Never pull the electrical wires when disconnecting an electrical connector-pull only on the connector

## GENERAL INFORMATION

---

### Intermittent Problems

Intermittent problems are problems that do not occur all the time and can be difficult to locate. For example. When a problem only occurs when the UTV is ridden over rough roads (vibration) or in wet conditions (water penetration). It is intermittent. To locate and repair intermittent problems. Simulate the condition when testing the components. Note the following:

1. Vibration---This is a common problem with loose or damaged electrical connectors
  - a. Perform a continuity test as described in the appropriate service procedure. Or under *Continuity Test* in this section
  - b. Lightly pull or wiggle the connectors while repeating the test. Do the same when checking the wiring harness and individual components. especially where the wires enter a housing or connector
  - c. A change in meter readings indicates a poor connection. Fine and repair the problem or replace the part. Check for wires with cracked or broken insulation

#### **NOTE**

**An analog ohmmeter is useful when making this type of test. Slight needle movements are apparent when indicating a loose connection**

2. Heat – This is another common problem with connectors or plugs that have loose or poor connections. As these connections heat up. The connection or joint expands and separates. Causing an open circuit. Other heat related problem occur when a component creates its own heat as it starts to fail or go bad
  - a. Troubleshoot the problem to help isolate the problem or area
  - b. To check a connector. Perform a continuity test as described in the appropriate service procedure. Or under *Continuity test* in this chapter. Then repeat the test while heating the ground. If the lamp comes on. The problem is the connection between the lamp and Connector with a heat gun or hair dryer. If the meter reading was normal (continuity) when the connector was cold, then fluctuated or read infinity when heat was applied, the connection is bad.
  - c. To check a component, wait until the engine is cold, then start and run the engine. Note operational differences when the engine is cold and hot.
  - d. If the engine does not start, isolate and remove the component. First test it at room temperature, and then after heating it with a hair dryer. A change in meter readings indicates a temperature problem.

#### **CAUTION**

**A heat gun or hair dryer will quickly raise the heat of the component being tested. Do not apply heat directly to the ICM or use heat in excess of 60°C (140°F) on any electrical component. If available, monitor heat with an infrared thermometer.**

3. Water—when this problem occurs in wet conditions, or in areas with high humidity, start and run the engine in a dry area. Then, with the engine running, spray water related problems repair themselves after the component becomes hot enough to dry itself.

## GENERAL INFORMATION

---

### Electrical component replacement

Most UTV dealerships and parts suppliers will not accept the return of any electrical part. If you cannot determine the exact cause of any electrical system malfunction. If you purchase a new electrical component(s), install it, and then find that the system still does not work properly, you will probably be unable to return the unit for a refund.

Consider any test results carefully before replacing a component that tests only slightly out of specification, especially resistance. A number of variables can affect test results dramatically. These include: the testing meter's internal circuitry, ambient temperature and conditions under which the machine has been operated. All instructions and specifications have been for accuracy: however. Successful test results depend to a great degree upon individual accuracy.

### Test Equipment

A test light can be constructed from a 12-volt light bulb with a pair of test leads carefully soldered to the bulb. To check for battery voltage in a circuit, attach one lead to ground and the other lead to various points along the circuit. The bulb lights when battery voltage is present.

A voltmeter is used in the same manner as the test light to find out if battery voltage is present in any given circuit. The voltmeter, unlike the test light, also indicates how much voltage is present at each test point. When using a voltmeter, attach the positive lead to the component or wire to be checked and the negative lead to a good ground.

### Ammeter

An ammeter measures the flow of current (amps) in a circuit when connected in series in a circuit, the ammeter determines if current is flowing through the circuit and if that current flow is excessive because of a short in the circuit. Current flow is often referred to as current draw. Comparing actual current draw in the circuit or component to the manufacturer's specified current draw provides useful diagnostic information.

### Self-powered test light

A self-powered test light can be constructed from a 12-volt light bulb, a pair of test leads and a 12-volt battery. When the test leads are touched together, the light bulb should go on.

Use a self-powered test light as follows:

1. Touch the test leads together to make sure the light bulb goes on. If not, correct the problem before using it in a test procedure.
2. Select two points within the circuit where there should be continuity.
3. Attach one lead of the self-powered test light to each point.
4. If there is continuity, the self-powered test light bulb will come on.
5. If there is no continuity, the self-powered test light bulb will not come on, indicating an open circuit.

### Ohmmeter

An ohmmeter measures the resistance (in ohms) to current flow in a circuit or component. Like the



## GENERAL INFORMATION

---

self-powered test light, an ohmmeter contains its own power source and should not be connected to a live circuit.

Ohmmeter may be analog type (needle scale) or digital type (LCD or LED readout). Both types of ohmmeter have a switch that allows the user to select different ranges of resistance for accurate readings. The analog ohmmeter also has a set-adjust control which is used to zero or calibrate the meter (digital ohmmeters do not require calibration).

An ohmmeter is used by connecting its test leads to the terminals or leads of the circuit or component to be tested. If an analog meter is used, it must be calibrated by touching the test leads together and turning the set-adjust knob until the meter needle reads zero. When the leads are uncrossed, the needle reads zero. When the leads are uncrossed, the needle should move to the other end of the scale indicating infinite resistance.

During a continuity test, a reading of infinity indicates that there is an open in the circuit or component. A reading of zero indicates continuity, that is, there is no measurable resistance in the meter needle falls between these two ends of the scale, this indicates the actual resistance, multiply the meter reading by the ohmmeter scale. For example, a meter reading of 5 multiplied by the R×100 scale is 5000 ohms of resistance.

### CAUTION

**Never connect an ohmmeter to a circuit which has power applied to it. Always disconnect the battery negative lead before using an ohmmeter.**

## Jumper wire

A jumper wire is a simple way to bypass a potential problem and isolate it to a particular point in a circuit. If a faulty circuit works properly with a jumper wire installed, an open exists between the two jumper points in the circuit.

To troubleshoot with a jumper wire, first use the wire to determine if the problem is on the ground side or the load side of a device. Test the ground by connecting a jumper between the lamp and a good ground. If the lamp does not come on with the jumper installed. The lamp's connection to ground is good so the problem is between the lamp and the power source.

To isolate the problem. Connect the jumper between the battery and the lamp. If it comes on. The problem is between these two points. Next. Connect the jumper between the battery and the fuse side of the switch. If the lamp comes on. The switch is good. By successively moving the jumper from one point to another. The problem can be isolated to a particular place in the circuit

Pay attention to the following when using a jumper wire:

1. Make sure the jumper wire gauge (thickness) is the same as that used in the circuit being tested. Smaller gauge wire will rapidly overheat and could melt
2. Install insulated boots over alligator clips. This prevents accidental grounding. Sparks or possible shock when working in cramped quarters
3. Jumper wires are temporary test measures only. Do not leave a jumper wire installed as a permanent solution. This creates a severe fire hazard that could easily lead to complete loss of the motorcycle
4. When using a jumper wire always install an inline fuse/fuse holder (available at most auto supply stores or electronic supply stores) to the jumper wire. Never use a jumper wire across

## GENERAL INFORMATION

---

any load (a component that is connected and turned on). This would result in a direct short and will blow the fuse(s)

### Test Procedures

#### Voltage test

Unless otherwise specified. Make all voltage tests with the electrical connectors still connected. Insert the test leads into the backside of the connector and make sure the test lead touches the electrical wire or metal terminal within the connector housing. If the test lead only touches the wire insulation. There will be a false reading

Always check both sides of the connector as one side may be loose or corroded. Thus preventing electrical flow through the connector. This type of test can be performed with a test or a voltmeter. A voltmeter gives the best results

#### **NOTE**

**If using a test light. It does not make any difference which test lead is attached to ground**

1. Attach the voltmeter negative test lead to a good ground (bare metal). Make sure the part used for ground is not insulated with a rubber gasket or rubber grommet
2. Attach the voltmeter positive test lead to the point to be tested
3. Turn the ignition switch on. If using a test light. The test light will come on if voltage is present. If using a voltmeter. Note the voltage reading. The reading should be within 1 volt of battery voltage. If the voltage is less. There is a problem in the circuit

#### Voltage drop test

The wires. Cables. Connectors and switches in an electrical circuit are designed to carry current with low resistance. This ensures that current can flow through the circuit with a minimum loss of voltage. Voltage drop indicates where there is resistance in a circuit. A higher than normal amount of resistance in a circuit decreases the flow of current and cause the voltage to drop between the source and destination in the circuit.

Because resistance causes voltage to drop. A voltmeter is used to measure voltage drop when current is running through the circuit. If the circuit has no resistance. There is no voltage drop so the voltmeter indicates 0 volts. The greater the resistance in a circuit. The greater the voltage drop reading.

To perform a voltage drop:

1. Connect the positive meter test lead to the electrical source (where electricity is coming from).
2. Connect the voltmeter negative test lead to the electrical load (where the electricity is going).
3. If necessary, activate the component(s) in the circuit. For example. If checking the voltage in the starter circuit, it would be necessary to push the starter button.
4. Read the voltage drop (difference in voltage between the source and destination) on the voltmeter.

Note the following:

## **GENERAL INFORMATION**

---

- a. The voltmeter should indicate 0 volts. If there is a drop of 0.5 volts or more. There is a problem within the circuit. A voltage drop reading of 12 volts indicates an open in the circuit.
- b. A voltage drop of 1 or more volts indicates that a circuit has excessive resistance.
- c. For example, consider a starting problem where the battery is fully charged but the starter motor turns over slowly. Voltage drop would be the difference in the voltage at the batter (source) and the voltage at the starter (destination) as the engine is being started (current is flowing through the batter cables). A corroded battery cable would cause a high voltage drop (high resistance) and slow engine cranking.
- d. Common sources of voltage drop are loose or contaminated connectors and poor ground connections.

### **Peak voltage test**

Peak voltage tests check the voltage output of the ignition coil and ignition pulse generator at normal cranking speed. These tests make it possible to identify ignition system problems quickly and accurately.

Peak voltage tests require a peak voltage adapter or tester. See Chapter Ten, Ignition System Testing.

### **Continuity Test**

A continuity test is used to determine the integrity of a circuit, wire or component. A circuit has continuity if it forms a complete circuit, that is, if there are no opens in either the electrical wires or components within the circuit. A circuit with an open. On the other hand, has no continuity.

This type of test can be performed with a self-powered test light or an ohmmeter. An ohmmeter gives the best results. If using an analog ohmmeter, calibrate the meter by touching the leads together and turning the calibration knob until the meter reads zero.

1. Disconnect the negative battery cable.
2. Attach one test lead (test light or ohmmeter) to one end of the part of the circuit to be tested.
3. Attach the other test lead to the other end of the part or the circuit to be tested.
4. The self-powered test lead comes on if there is continuity. An ohmmeter reads 0 or very low resistance if there is continuity. A reading of infinite resistance if there is continuity. A reading of infinite resistance indicates no continuity, the circuit is open.

### **Testing for a short with a self-powered test light or ohmmeter**

1. Disconnect the negative battery cable.
2. Remove the blown fuse.
3. Connect one test lead of the test light or ohmmeter to the load side (battery side) of the fuse terminal in the starter relay.
4. Connect the other test lead to a good ground (bare metal). Make sure the part used for a ground is not insulated with a rubber gasket or rubber grommet.
5. With the self-powered test light or ohmmeter attached to the fuse terminal and ground, wiggle the wiring harness relating to the suspect circuit at various intervals. Start next to the fuse terminals and work away from the fuse terminal. Watch the self-powered test light or ohmmeter while progressing

## GENERAL INFORMATION

---

along the harness.

6. If the test light blinks or the needle on the ohmmeter moves, there is a short-to-ground at that point in the harness.

### Testing for a short with a test light or voltmeter

1. Remove the blown fuse.
2. Connect the test light or voltmeter across the fuse terminals in the starter relay. Turn the ignition switch ON and check for battery voltage.
3. With the test light or voltmeter attached to the fuse terminals, wiggle the wiring harness relating to the suspect circuit at various intervals. Start next to the fuse terminal and work systematically away from the fuse terminal. Watch the test light or voltmeter while progressing along the harness.
4. If the test light blinks or if the needle on the voltmeter moves, there is a short-to-ground at that point in the harness.

## BRAKE SYSTEM

The front and rear brake units are critical to riding performance and safety. Inspect the front and rear brakes frequently and repair any problem immediately. When replacing or refilling the brake fluid, use only DOT 4 brake fluid from a closed container.

Always check the brake operation before riding the motorcycle.

### Soft or Spongy Brake Lever or Pedal

Operate the front brake lever or rear brake pedal and check to see if the lever travel distance increases. If the lever travel does increase while being operated, or feels soft or spongy, there may be air in the brake line. In this condition, the brake system is not capable of producing sufficient brake force. When there is an increase in lever or pedal travel or when the brake feels soft or spongy, check the following possible causes:

1. Air in system.

#### **WARNING**

*If the fluid level drops too low, air can enter the hydraulic system through the master cylinder. Air can also enter the system from loose or damaged hose fittings. Air in the hydraulic system causes a soft or spongy brake lever action. This condition is noticeable and reduces brake performance. When it is suspected that air has entered the hydraulic system, flush the brake system and bleed the brakes as described in Chapter Fifteen.*

2. Low brake fluid level.

#### **WARNING**

*As the brake pads wear, the brake fluid level in*

## GENERAL INFORMATION

---

*the master cylinder reservoir drops. Whenever adding brake fluid to the reservoir, visually check the brake pads for wear. If it does not appear that there is an increase in pad wear, check the brake hoses, lines and banjo bolts for leaks.*

3. Leak in the brake system.
4. Contaminated brake fluid.
5. Plugged brake fluid passages.
6. Damaged brake lever or pedal assembly.
7. Worn or damaged brake pads.
8. Warped brake disc.
9. Contaminated brake pads and disc.

### **WARNING**

*A leaking fork seal can allow oil to contaminate the brake pads and disc.*

10. Worn or damaged master cylinder cups and/or cylinder bore.
11. Worn or damaged brake caliper piston seals.
12. Contaminated master cylinder assembly.
13. Contaminated brake caliper assembly.
14. Brake caliper not sliding correctly on slide pins.
15. Sticking master cylinder piston assembly.
16. Sticking brake caliper pistons.

## Brake Drag

When the brakes drag, the brake pads are not capable of moving away from the brake disc when the brake lever or pedal is released. Any of the following causes, if they occur, would prevent correct brake pad movement and cause brake drag.

1. Warped or damaged brake disc.
2. Brake caliper not sliding correctly on slide pins.
3. Sticking or damaged brake caliper pistons.
4. Contaminated brake pads and disc.
5. Plugged master cylinder port.
6. Contaminated brake fluid and hydraulic passages.
7. Restricted brake hose joint.
8. Loose brake disc mounting bolts.
9. Damaged or misaligned wheel.
10. Incorrect wheel alignment.
11. Incorrectly installed brake caliper.
12. Damaged front or rear wheel.

## Hard Brake Lever or Pedal Operation

When applying the brakes and there is sufficient brake performance but the operation of brake

## **GENERAL INFORMATION**

---

lever feels excessively hard, check for the following possible causes:

1. Clogged brake hydraulic system.
2. Sticking caliper piston.
3. Sticking master cylinder piston.
4. Glazed or worn brake pads.
5. Mismatched brake pads.
6. Damaged front brake lever.
7. Damaged rear brake pedal.
8. Brake caliper not sliding correctly on slide pins.
9. Worn or damaged brake caliper seals.

### **Brake Grabs**

1. Damaged brake pad pin bolt. Look for steps or cracks along the pad pin bolt surface.
2. Contaminated brake pads and disc.
3. Incorrect wheel alignment.
4. Warped brake disc.
5. Loose brake disc mounting bolts.
6. Brake caliper not sliding correctly on slide pins.
7. Mismatched brake pads.
8. Damaged wheel bearings.

### **Brake Squeal or Chatter**

1. Contaminated brake pads and disc.
2. Incorrectly installed brake caliper.
3. Warped brake disc.
4. Incorrect wheel alignment.
5. Mismatched brake pads.
6. Incorrectly installed brake pads.
7. Damaged or missing brake pad spring or pad retainer.

### **Leaking Brake Caliper**

1. Damaged dust and piston seals.
2. Damaged cylinder bore.
3. Loose caliper body bolts.
4. Loose banjo bolt.
5. Damaged banjo bolt washers.
6. Damaged banjo bolt threads in caliper body.

### **Leaking Master Cylinder**

1. Damaged piston secondary seal.
2. Damaged piston snap ring/ snap ring groove.
3. Worn or damaged master cylinder bore.

## **GENERAL INFORMATION**

---

4. Loose banjo bolt washers.
5. Damaged banjo bolt washers.
6. Damaged banjo bolt threads in master cylinder body.
7. Loose or damaged reservoir cap.

# SPECIFICATIONS

## SPECIFICATIONS

### HOW TO CONVERSION TABLE OF UNIT

#### (1) How to use conversion table

All the specified documents in this manual are taken SI and Metric as unit. With the following conversion table, metric unit could be converted into imperial unit.

Sample:

METRIC	MULTIPLY	IMPERIAL	
mm	0.03937	=in	
2mm ×	0.03937	=0.08in	

Conversion table

Conversion between metric and imperial			
	Know unit	Multiply	Product
Torque	m·kg	7.233	ft·lb
	m·kg	86.794	in·lb
	cm·kg	0.0723	ft·lb
	cm·kg	0.8679	in·lb
Weight	kg	2.205	lb
	g	0.03527	oz
Length	km/hr	0.6214	mph
	km	0.6214	mi
	m	3.281	ft
	m	1.094	yd
	cm	0.3937	in
	mm	0.03937	in
Volume/capacity	cc (cm <sup>3</sup> )	0.03527	oz (IMP liq.)
	cc (cm <sup>3</sup> )	0.06102	cu-in
	lit (liter)	0.8799	qt (IMP liq.)
	lit (liter)	0.2199	gal (IMP liq.)
Others	kg/mm	55.997	lb/in
	kg/cm <sup>2</sup>	14.2234	psi (lb/in <sup>2</sup> )
	Centigrade	9/5 (°C) +32	Fahrenheit (°F)

#### (2) Definition of unit

Unit	Read	Definition	Measurement
mm	Millimetre	1 mm=10 <sup>-3</sup> Meter	Length
cm	Centimetre	1 cm =10 <sup>-2</sup> Meter	Length
kg	Kilogram	1 kg =10 <sup>3</sup> Gram	Weight
N	Newton	1N=1 kg×meter/second <sup>2</sup>	Force
N.m	Newton meter	1 Nm=1Newton×1meter	Torque
kgf.m	Meter Kilogram	1 kgf.m =1Meter×1kgf	Torque
Pa	Pascal	1 Pa=1Newton/1meter <sup>2</sup>	Pressure
N/mm	Newton per millimeter	1 N/mm =1Newton/ millimeter	Rigid of spring
L	Litre	—	Volume of capacity
cm <sup>3</sup>	Cubic centimeter	—	
r/min	Revolutions per minute	—	Rotational speed



# SPECIFICATIONS

## GEBERAR SPECIFICATIONS

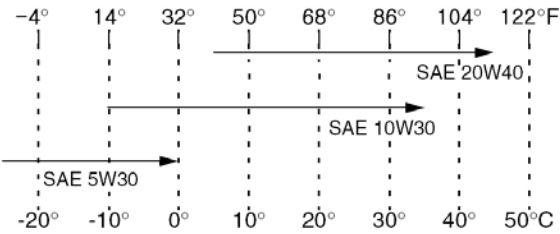
Item	Standard
<b>Dimensions :</b> Overall length Overall width Overall height Seat height Wheelbase Minimum ground clearance Minimum turning radius	2,980mm (117.3in) 1,550mm (61.0 in) 1,950mm (76.8in) 875mm (34.5in) 1,950mm (76.8in) 310 mm (12.2 in) 4,300mm (169.3in)
<b>Basic weight :</b> With oil and full fuel tank	743kg (1,638 lb)
<b>Engine :</b> Model Engine type Cylinder arrangement Displacement Bore×stroke Compression ratio Starting system Lubrication system	HS191MR Liquid cooled 4-stroke, Water cool Forward-inclined single cylinder 546cm <sup>3</sup> 91×84mm 9.6:1 Electric starter Wet sump
<b>Engine oil :</b>   <p>The chart shows temperature ranges for three SAE oil grades: SAE 5W30 (from -20°C to 0°C), SAE 10W30 (from -10°C to 40°C), and SAE 20W40 (from 0°C to 40°C). The top axis shows Fahrenheit temperatures from -4°F to 122°F, and the bottom axis shows Celsius temperatures from -20°C to 50°C.</p> Final gear oil Differential gear oil Engine oil Periodic oil change With oil filter replacement Total amount	API service SE,SF,SG type or higher     SAE80 API GL-4 Hypoid gear oil SAE80 API GL-5 Hypoid gear oil  1.90 L (1.67 Imp qt, 2.01 US qt) 2.10 L (1.85 Imp qt, 2.22 US qt) 2.40 L (2.11 Imp qt, 2.54 US qt)
<b>Air filter</b>	Wet type element
<b>Fuel</b> Type Fuel tank capacity	Unleaded gasoline only 28L (6.16 Imp gal, 7.40 US gal)



## SPECIFICATIONS

Item	Standard
<b>Electrical</b>	
Ignition system	ECU
Generator system	A.C. magneto
Battery type	GS U1-9
Battery capacity	12 V, 30.0Ah
Headlight type	HS1
Bulb wattage × quantity	
Headlight	12V, 35W/35W × 2
Front Position Lamp	12V, 0.5W (LED)
Front direction indicator	12V, 0.7 W (LED)
Rear direction indicator	12V, 0.85W (LED)
Rear position lamp	12V, 0.5W (LED)
Brake Lamp	12V, 1W (LED)
Neutral	LED
Reverse	LCD screen
Coolant temperature	LCD screen, Code display
Parking brake	LED
Four-wheel drive	LCD screen
Differential gear lock	LCD screen

# SPECIFICATIONS

## ENGINE SPECIFICATIONS

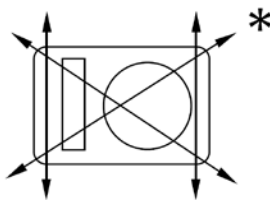
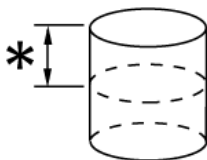
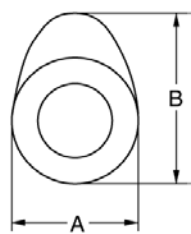
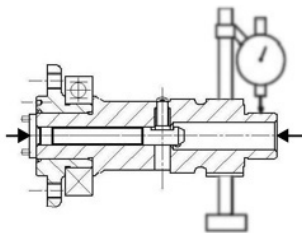
Item	Standard	Limit
<b>Cylinder head</b> Warp limit * 	----	0.03 mm (0.0012 in)
<b>Cylinder</b> Bore size Measuring point * 	84.503 ~ 84.527mm (3.327 ~ 3.328 in) 50 mm (1.97 in)	----
<b>Camshaft</b> Drive method Cam dimensions 	Chain drive (Left)	----
Intake <div style="display: flex; justify-content: space-between; width: 100%;"> <span style="width: 20%;"></span> <span style="width: 10%;">“A”</span> <span style="width: 60%;">32.30~32.20 mm (1.271 ~ 1.268in)</span> </div> <div style="display: flex; justify-content: space-between; width: 100%;"> <span style="width: 20%;"></span> <span style="width: 10%;">“B”</span> <span style="width: 60%;">40.88 ~ 40.78 mm (1.6094 ~ 1.6055in)</span> </div>		
Exhaust <div style="display: flex; justify-content: space-between; width: 100%;"> <span style="width: 20%;"></span> <span style="width: 10%;">“A”</span> <span style="width: 60%;">32.30 ~ 32.20 mm (1.272 ~ 1.268 in)</span> </div> <div style="display: flex; justify-content: space-between; width: 100%;"> <span style="width: 20%;"></span> <span style="width: 10%;">“B”</span> <span style="width: 60%;">40.95 ~ 40.85 mm (1.6122~ 1.6083 in)</span> </div>		
Camshaft runout limit 	----	

## SPECIFICATIONS

Item	Standard	Limit	
<b>Cam chain</b>			
No. of links	124		
Cam chain adjustment method	Automatic		
<b>Rocker arm/rocker arm shaft</b>			
Rocker arm inside diameter	12.000 ~ 12.018 mm (0.4724 ~ 0.4731 in)		
Shaft outside diameter	11.976 ~ 11.991 mm (0.4715 ~ 0.4721 in)	----	
Arm-to-shaft clearance	0.009 ~ 0.042 mm (0.0004 ~ 0.0017 in)	----	
<b>Valve, valve seat, valve guide</b>			
Valve clearance (cold)    IN	0.10 ~ 0.15 mm (0.0039 ~ 0.0059 in)	----	
EX	0.15 ~ 0.20 mm (0.0059 ~ 0.0079 in)	----	
Valve dimensions			
head diameter	face width	seat width	margin thickness
"A" head diameter	IN	39.9 ~ 40.1 mm (1.5709 ~ 1.5787 in)	----
	EX	33.9 ~ 33.98 mm (1.3346 ~ 1.3378 in)	----
"B" face width	IN	2.25 mm (0.0900 in)	----
	EX	2.26 mm (0.0890 in)	----
"C" seat width	IN	0.9 ~ 1.1 mm (0.0354 ~ 0.0433 in)	1.6 mm (0.0630 in)
	EX	0.9 ~ 1.1 mm (0.0354 ~ 0.0433 in)	1.6 mm (0.0630 in)
"D" margin thickness	IN	0.85 ~ 1.15 mm (0.0335 ~ 0.0453 in)	----
	EX	0.85 ~ 1.15 mm (0.0335 ~ 0.0453 in)	----
Stem outside diameter	IN	5.975 ~ 5.990 mm (0.2352 ~ 0.2358 in)	5.945 mm (0.2341 in)
	EX	5.960 ~ 5.975 mm (0.2346 ~ 0.2352 in)	5.930 mm (0.2335 in)
Guide inside diameter	IN	6.000 ~ 6.012 mm (0.2362 ~ 0.2367 in)	6.050 mm (0.2559 in)
	EX	6.000 ~ 6.012 mm (0.2362 ~ 0.2367 in)	6.050 mm (0.2559 in)

## SPECIFICATIONS

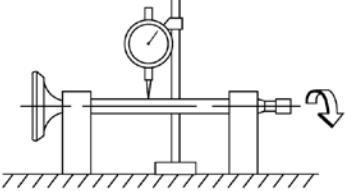
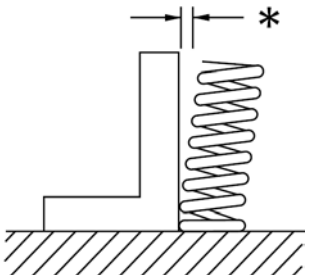
Item	Standard	Limit
Stem-to-guide clearance	IN 0.010 ~ 0.037 mm (0.0004 ~ 0.0015 in)	0.08 mm (0.0031 in)
	EX 0.025 ~ 0.052 mm (0.0010 ~ 0.0020 in)	0.10 mm (0.0039 in)
Stem runout limit	----	0.01 mm (0.0004 in)
		
Valve seat width	IN 0.9 ~ 1.1 mm (0.0354 ~ 0.0433 in)	----
	EX 0.9 ~ 1.1 mm (0.0354 ~ 0.0433 in)	----
<b>Valve spring</b>		
Inner spring		
Free length		----
Outside spring	IN 42.5mm (1.67in)	----
	EX 42.5mm(1.67in)	----
Within spring	IN 39.0mm(1.54)	----
	EX 39.0mm(1.54)	----
Set length (valve closed)		
Outside spring	IN 36.0 mm (1.42in)	----
	EX 36.0 mm (1.42in)	----
Within spring	IN 33.0 mm(1.30 in)	----
	EX 33.0 mm(1.30 in)	----
Compressed pressure (installed)		
Outside spring	IN 240.0~260.0N (24.49~26.53 kg)	
	EX 240.0~260.0N (24.49~26.53 kg)	
Within spring	IN 110.0 ~ 130.0 N (11.22~13.27kg)	
	EX 110.0 ~ 130.0 N (11.22~13.27kg)	
Tilt limit *	IN ----	----
	EX ----	----
		
Direction of winding		
(top view)	IN Clockwise	
	EX Clockwise	

## SPECIFICATIONS

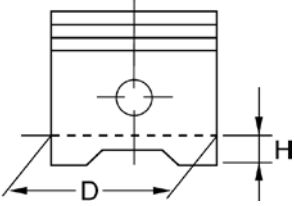
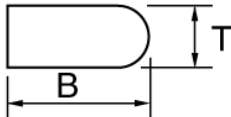
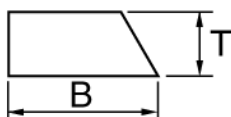
Item	Standard	Limit
<b>Piston</b>		
Piston to cylinder clearance	0.050 ~ 0.070 mm (0.0020 ~ 0.0028 in)	0.15 mm (0.0059 in)
Piston size "D"	84.45 ~ 84.47 mm (3.3248 ~ 3.3256 in)	----
		----
Measuring point "H"	15mm (0.59in)	----
Piston off-set	0.5mm(0.0197in)	----
Off-set direction	Intake side	----
Piston pin bore inside diameter	22.002 ~ 20.010 mm (0.8662 ~ 0.7878in)	22.045 mm (0.8679 in)
Piston pin outside diameter	19.991 ~ 20.000mm ( 0.7870~ 0.7874 in)	21.971 mm (0.8650 in)
<b>Piston rings</b>		
Top ring		
		
Type	Barrel	----
Dimensions (B× □T)	1.0 ×3.0mm (0.03937× 0.1181in)	----
End gap (installed)	0.30 ~ 0.45 mm (0.0118 ~ 0.0177 in)	0.70 mm (0.0276 in)
Side clearance (installed)	0.04 ~ 0.08 mm (0.0016 ~ 0.0031 in)	0.13 mm (0.0051 in)
2nd ring		
		
Type	Taper	----
Dimensions (B × □T)	1.0×3.6 mm (0.03937×0.1417 in)	----
End gap (installed)	0.30 ~ 0.45 mm (0.0118 ~ 0.0177 in)	----
Side clearance	0.03 ~ 0.07 mm (0.0012 ~ 0.0028 in)	----

## SPECIFICATIONS

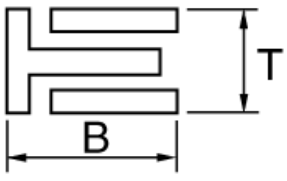
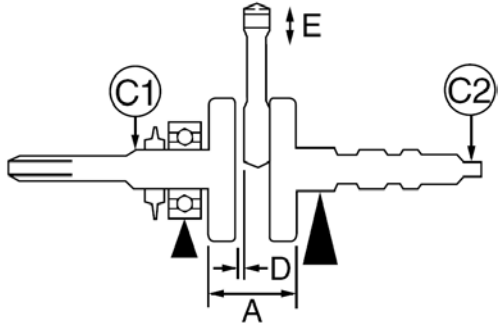
Item	Standard	Limit
<p>Oil ring</p> 		
Dimensions (B×T)	2.0×2.85 mm (0.0787×0.1122in)	----
End gap (installed)	0.20 ~ 0.70 mm (0.0079 ~ 0.0276 in)	----
Side clearance	0.06 ~ 0.15 mm (0.0024 ~ 0.0059 in)	
<p><b>Crankshaft</b></p> 		
Crank width "A"	74.95 ~ 75.00 mm (2.9508 ~ 2.9528 in)	----
Runout limit C1 C2	---- ----	0.03 mm (0.0012 in)
Big end side clearance "D"	0.35 ~ 0.65 mm (0.0138 ~ 0.0256 in)	0.03 mm (0.0012 in)
Big end radial clearance "E"	0.010 ~ 0.025 mm (0.0004 ~ 0.0010 in)	1.0 mm (0.0394 in)
Automatic centrifugal clutch Clutch engagement speed	1800r/min	



## SPECIFICATIONS

Item	Standard	Limit
<b>Shifter</b>		
Shifter type	Shift drum and guide bar	----
<b>Air filter oil grade</b>	Engine oil	----
<b>Oil pump</b>		
Oil filter type	Foam	----
Oil pump type	Trochoid	---
Tip clearance	0.15 mm (0.0059 in)	0.23 mm (0.0091 in)
Side clearance	0.03 ~ 0.10 mm (0.0012 ~ 0.0039 in)	0.17 mm (0.0067 in)
Body clearance	0.09 ~ 0.17 mm (0.0035 ~ 0.0067 in)	0.24 mm (0.0094 in)
Bypass valve setting pressure	441.0 ~ 637.0 Kpa (4.41 ~ 6.37 kg/cm <sup>2</sup> , 62.7 ~ 90.6 psi)	----
Oil pressure (hot)	65 Kpa (0.65 kg/cm <sup>2</sup> , 9.2 psi) at 1,500 r/min	----
Pressure check location	Cylinder head	
<b>Water pump</b>		
Type	Single-suction centrifugal pump	----
Reduction ratio	32/31 (1.032)	----
<b>Shaft drive</b>		
Middle gear backlash	0.1 ~ 0.3 mm (0.004 ~ 0.012 in)	----
Final gear backlash	0.1 ~ 0.3 mm (0.004 ~ 0.012 in)	----
Differential gear backlash	0.05 ~ 0.25 mm(0.002 ~ 0.010 in)	----
<b>Cooling system</b>		
Radiator core		
Width	510mm (20.08 in)	----
Height	397 mm (15.63 in)	----
Thickness	162.5 mm (6.40in)	----
Radiator cap opening pressure	900Kpa (9.2kg /cm <sup>2</sup> , 130.5psi)	----
Radiator capacity (including all routes)	1.8 L (1.63 Imp qt, 1.90US qt)	----
Coolant reservoir		
Capacity	0.25L (0.23 Imp qt, 0.26 US qt)	----
From low to full level	0.20 L (0.15 Imp qt, 0.21 US qt)	----

# SPECIFICATIONS

## CHASSIS SPECIFICATIONS

Item	Standard	Limit
<b>Steering system</b>		
Type	Rack and pinion	----
<b>Front suspension</b>		
Shock absorber travel	160 mm (6.30 in)	----
Spring free length	314 mm (12.36 in)	----
Spring rate	25.72N/mm(2.62kg/mm)	----
Stroke	35-140 mm (1.38 ~ 5.51in)	----
<b>Rear suspension</b>		
Shock absorber travel	115 mm (4.53 in)	----
Spring free length	284mm (11.18 in)	----
Spring rate	43.18 N/mm (4.41 kg/mm)	----
Stroke	5 ~ 115 mm (0.20 ~ 4.53 in)	----
<b>Front wheel</b>		
Type	Aluminum Alloy wheel	----
Rim size	14 ×9 AT	----
Rim material	A356	----
Rim runout limit	radial	1.0 mm (0.04in)
	lateral	1.0 mm (0.04 in)
<b>Rear wheel</b>		
Type	Aluminum Alloy wheel	----
Rim size	14×11AT	----
Rim material	A356	----
Rim runout limit	radial	2.0 mm (0.08 in)
	lateral	2.0 mm (0.08 in)
<b>Brake lever and brake pedal</b>		
Accelerator pedal free play	2 ~ 3mm (0.079 ~ 0.118 in)	----
Brake pedal free play	2 ~ 3mm (0.079 ~ 0.118 in)	----
Parking brake cable free play	2 ~ 3 mm (0.079 ~ 0.118 in)	----

## SPECIFICATIONS

Item	Standard	Limit
<b>Front disc brake</b>		
Type	Single	----
Disc outside diameter × thickness	200× 5 mm (7.87 × 0.20 in)	----
Pad thickness           inner	6.0 mm (0.24 in)	----
Pad thickness           outer	6.0 mm (0.24 in)	----
Master cylinder inside diameter	19.0mm (0.75in)	----
Caliper cylinder inside diameter	40.0mm (1.57in)	----
Brake fluid type	DOT 3	----
<b>Rear disc brake</b>		
Type	Dual	----
Disc outside diameter × thickness	200×5 mm (7.87× 0.20in)	----
Pad thickness           inner	6.0 mm (0.24 in)	----
Pad thickness           outer	6.0 mm (0.24 in)	----
Master cylinder inside diameter	19.0mm (0.75in)	----
Caliper cylinder inside diameter	25.0mm (0.98in)	----
Brake fluid type	DOT 3	----

# SPECIFICATIONS

## ELECTRICAL SPECIFICATIONS

Item	Standard	Limit
<b>Voltage</b>	12 V	----
<b>Ignition system</b>		
Ignition timing (BTDC)	8°±1°before TDC	----
Advancer type	ECU Digital type	----
<b>Ignition coil</b>		
Minimum spark gap	6 mm (0.24 in)	----
Primary winding resistance	0.18 ~ 0.28 Ωat 20 °C (68 °F)	----
Secondary winding resistance	6.32 ~ 9.48 kΩat 20 °C (68 °F)	----
<b>Spark plug cap</b>		
Resistance	5.0~5.5 kΩ	----
<b>High voltage cap</b>		
Resistance	4.5~5.0 kΩ	
<b>Oxygen sensor</b>		
type	25325359	
<b>Charging system</b>		
Nominal output	14 V 28 A at 4,500 r/min	----
Charging coil resistance/color	0.32 ~ 0.43Ωat 20 °C (68 °F)/White – White – White	----
<b>Rectifier/regulator</b>		
Regulator type	Semi conductor-Switch type	----
No load regulated voltage (DC)	14.1 ~ 14.9 V	----
Capacity	30 A	----
Withstand voltage	200 V	----
<b>Battery</b>		
Specific gravity	1.32	----
<b>Circuit breaker</b>		
Type	Fuse	----
Lighting system fuse	15 A×1	
EFI system and instrument insurance	15 A×1	----
Auxiliary DC jack fuse 、 horn	15 A×1	----
Four-wheel drive fuse	10 A×1	----
EFI system and instrument often energized insurance	5A×1	----
Signaling system fuse	10 A×1	----
Backup fuse	5 A×1	
	10 A×1	
	15 A×1	

## SPECIFICATIONS

Item	Standard	Limit
<b>Radiator fan</b> Running rpm	2,950 r/min	
<b>Electric starter system</b> Type	Constant mesh type	----
Starter motor		----
Output	0.8 kW	----
Armature coil resistance	0.025 ~ 0.035 Ω	----
Brush overall length	12.5 mm (0.49 in)	----
Starter relay		
Amperage rating	180 A	----
Coil winding resistance	4.18 ~ 4.62                      □□at 20	-----

## SPECIFICATIONS

### LUBRICATION POINTS AND LUBRICANT TYPES

#### Engine

Lubrication points	Lubricant
Oil seal lips	Apply lithium-soap-based grease
Bearings	Apply engine oil
O-rings	Apply lithium-soap-based grease
Piston, piston ring	Apply engine oil
Piston pin	Apply engine oil
Buffer boss and balancer drive gear	Apply engine oil
Crankshaft seal and spacer	Apply engine oil
Valve stem	Apply molybdenum disulfide oil
Valve stem end	Apply molybdenum disulfide oil
Rocker arm shaft	Apply engine oil
Rocker arm	Apply molybdenum disulfide grease
Camshaft lobe and journal	Apply molybdenum disulfide grease
Oil pump assembly	Apply engine oil
Oil filter cartridge O-ring	Apply lithium-soap-based grease
Starter idle gear shaft	Apply molybdenum disulfide grease
Starter wheel gear	Apply engine oil
Clutch housing assembly shaft end	Apply lithium-soap-based grease
Clutch carrier assembly	Apply engine oil
One-way clutch bearing	Apply molybdenum disulfide grease
Middle driven shaft splines	Apply molybdenum disulfide oil
Drive axle, driven sprocket, high wheel gear, and low wheel gear	Apply molybdenum disulfide oil
Middle drive gear and clutch dog shift fork groove	Apply molybdenum disulfide oil
Driven chain/sprocket	Apply engine oil
Shift drum	Apply engine oil
Shift fork guide bar	Apply engine oil
Shift drum stopper ball	Apply engine oil
Shift lever 2 assembly	Apply lithium-soap-based grease
Shift lever 1	Apply engine oil
Shift lever 1 and shift lever 2 assembly mating surface	Apply engine oil

## SPECIFICATIONS

### CHASSIS

Lubrication points	Lubricant
Lip of oil seal (full)	Light lithium-base grease
o-ring(full)	Light lithium-base grease
Steering shaft (upper end ,lower end)	Light lithium-base grease
Ball connection of steering pushing rod	Light lithium-base grease
Front wheel fork(ball-shaped joint)	Light lithium-base grease
Front wheel bearing	Grease used for bearing
Front & rear brake	Light lithium-base grease
Dust-proof ring of brake	Light lithium-base grease
Joint of front brake cable	Light lithium-base grease
Front brake lever axle and rear brake lever axle	Light lithium-base grease
Adjusting nut and pin of front brake cable	Light lithium-base grease
Adjusting nut and pin of rear brake cable	Light lithium-base grease
Rear brake pedal pivot and brake pedal axle hole	Light lithium-base grease
Throttle rotating frame shaft and end section of throttle cable	Light lithium-base grease
Reverse gear lever pivot	Light lithium-base grease
Connection bolt of rear wheel fork and frame,rear wheel fork bearing	Light lithium-base grease
Rubber sleeve and rear wheel fork	Seal gum
Rear shock absorber bushing	Light lithium-base grease

**SPECIFICATIONS**

**HYDROGRAPHIC CHART**

Hydrographic chart

- : Pressure
- : splash

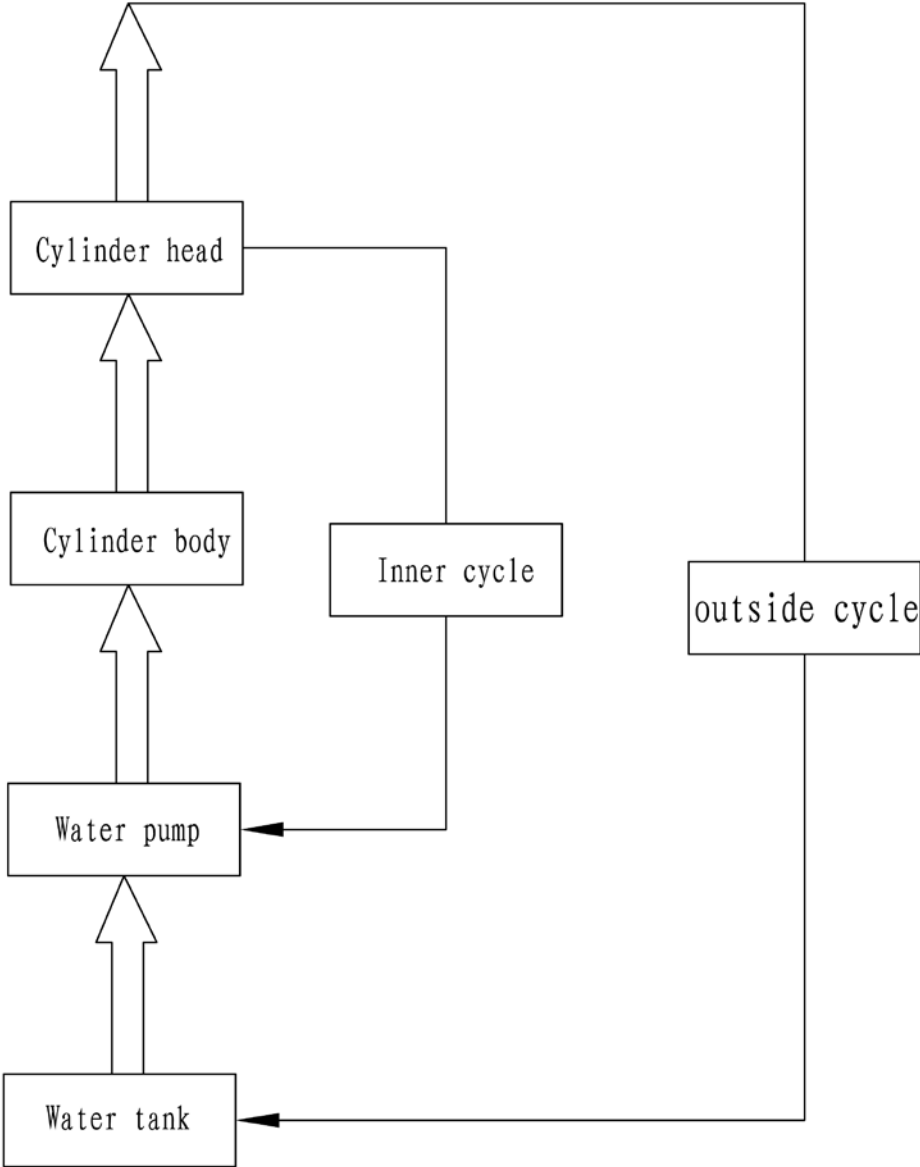



# SPECIFICATIONS

## LUBRICATION OIL WAY

### LUBRICATION OIL WAY

⇨ : Pressure

→ : splashing oil

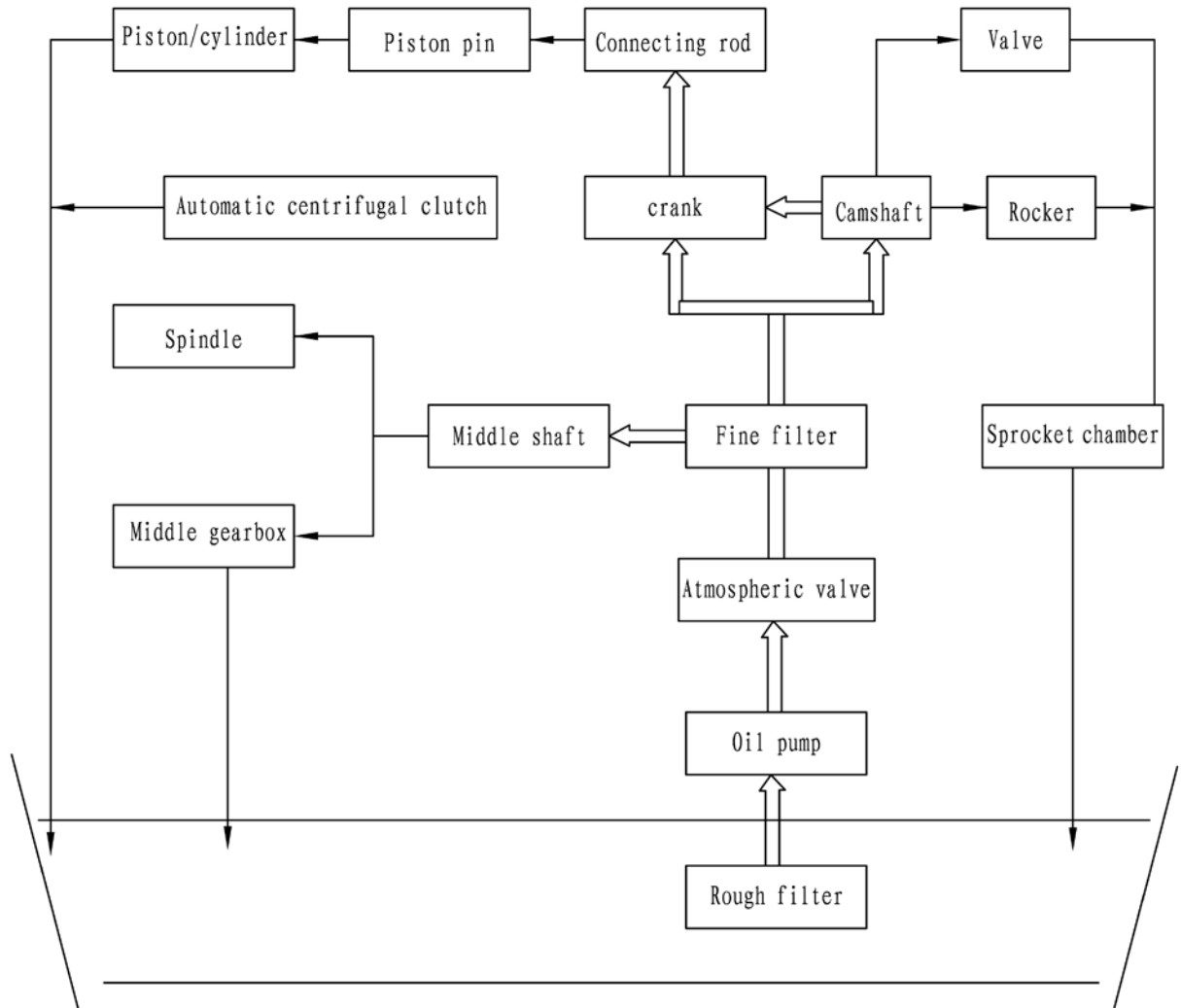

## MAINTENANCE AND ADJUSTMENT OF THE UTV

### MAINTENANCE AND ADJUSTMENT OF THE UTV

#### **CAUTION:**

Be sure you have sufficient knowledge, experience, the proper replacement parts and tools before you attempt any vehicle maintenance task.

If you don't have the knowledge and equipment which are necessary to perform the maintenance task, consult your local dealer.

#### MAINTENANCE SCHEDULE

ITEM	MAINTENANCE INTERVAL (WHICHEVER COMES FIRST)			REMARKS
	Hours	Frequency	Miles (KM)	
<b>Pre-Ride Inspection Check</b>				
Steering	-	Pre-Ride	-	Inspect for loose hardware or abnormal wear
Front-suspension	-	Pre-Ride	-	Inspect for loose hardware or abnormal wear
Rear-suspension	-	Pre-Ride	-	Inspect for loose hardware or abnormal wear
Tires	-	Pre-Ride	-	Proper tire pressure
Brake fluid level	-	Pre-Ride	-	Inspect and add if needed
Brake pedal travel	-	Pre-Ride	-	See Owner's Manual
Brake systems	-	Pre-Ride	-	Make adjustments as needed.
Lug Nuts	-	Pre-Ride	-	Ensure lug nuts are torque to spec
Frame fasteners	-	Pre-Ride	-	All fasteners are secured
Engine Oil Level	-	Pre-Ride	-	Inspect and add if needed
Coolant	-	Pre-Ride	-	Inspect and add if needed
Head / Tail / Brake Lights	-	Pre-Ride	-	Check operation
<b>Break-In Maintenance Check</b>				
Engine Oil/Filter change	10	-	First 50 (75)	Replace break-in oil & filter with proper oil type
Transmission	20	-	First 100 (150)	Initial fluid level inspection; add lubricant if needed
Toe adjustment	20	-	First 100 (150)	Inspect periodically; adjust when parts are replaced
Clutches (Drive and Driven)	20	-	First 100 (150)	Inspect; clean; replace worn parts
<b>Routine Maintenance Check (performed at each interval below, whichever comes first)</b>				
Air filter	5 H	-	-	Inspect; replace as needed
Brake pad wear	20 H	Monthly	250 (402)	Inspect periodically
Throttle Body Intake	20 H	1 M	250 (402)	Inspect duct for proper sealing/air leaks
Battery	20H	Monthly	250 (402)	Check terminals; clean; test
Fuel System	25 H	Monthly	250 (402)	Check lines & fittings for leaks
General lubrication	25H	3 M	250 (402)	Lubricate all fittings, pivots, cables, etc.
Shift Linkage	25H	3 M	250 (402)	Inspect, lubricate, adjust
Engine Oil & Filter	50 H	6 M	500 (800)	Replace
Steering	50 H	6 M	500 (800)	Lubricate
Front / Rear Gearcase Fluid	50H	6 M	500 (800)	Change Fluid
Front / Rear Stabilizer Bars	50H	6 M	500 (800)	Lubricate and inspect bushings
Throttle Pedal/Cable	50 H	6 M	500 (800)	Inspect for free movement & lubricate
Drive Belt	50 H	6 M	500 (800)	Inspect; replace as needed

## MAINTENANCE AND ADJUSTMENT OF THE UTV

ITEM	MAINTENANCE INTERVAL (WHICHEVER COMES FIRST)			REMARKS
	Hours	Frequency	Miles (KM)	
Antifreeze Coolant	50 H	6 M	500 (800)	Pressure Test / Add Fluid
Transmission Fluid	50 H	6 M	500 (800)	Replace
Engine mounts	100 H	12 M	1000 (1600)	Inspect; replace as needed
Cooling Hoses	100 H	12 M	1000 (1600)	Inspect for cracks and leaks
Drive Shafts	100H	12M	1000 (1600)	Remove and grease
Spark plug	100 H	12 M	1000 (1600)	inspect; replace as needed
Clutches (Drive and Driven)	100 H	12 M	1000 (1600)	Inspect; clean; replace worn parts
Wiring	100 H	12 M	1000 (1600)	Inspect for wear & routing
Wheel Bearings	100 H	12 M	1000 (1600)	Inspect; replace as needed
Shocks	100 H	12 M	1000 (1600)	Check for oil leaks
Cam Chain Tensioner	100H	12 M	1000 (1600)	Check; replace as needed
Brake Fluid	100 H	12M	1000 (1600)	Change every two years
Suspension Components	100H	12M	1000 (1600)	Inspect; replace if necessary
Spark arrestor	100H	12 M	-	Clean out
Valve clearance	100 H	12M	1000 (1600)	Inspect; adjust
<b>Extreme Maintenance Check</b> (cut the Routine Maintenance Schedule in half)				
*Service Note: Under extreme use, change gear case fluid every 25 hours. "Extreme Use" is defined as constant 4WD operation on hilly or mountainous terrain, or if 4WD is the primary mode of operation.				

### LUBRICATION RECOMMENDATIONS

Check and lubricate all components at the intervals outlined in the Periodic Maintenance Chart above, or more often under severe use, such as wet or dusty conditions. Items not listed in the chart should be lubricated at the general lubrication interval.

ITEM	LUBE	METHOD
Engine Oil	See Viscosity Chart (10-3) API-SJ & JASO/MA	Add to proper level on dipstick.
Brake Fluid	DOT 3 or 4 Brake Fluid	Maintain level between fill lines.
Rear Differential	SAE 80w90	Fill to bottom of fill plug or 0.455L or 14 oz.)
Front Differential	Dextron 3 ATF	Fill to bottom of fill plug or (volume of oil)
Drive Shaft	U-Joint Grease	Locate fittings and grease.

### ENGINE OIL

Always check and change the oil at the intervals outlined in the Service Interval Chart above. Always use the recommended engine oil. Always change the oil filter whenever changing oil.

Vehicle operation with insufficient, deteriorated, or contaminated engine oil will cause accelerated wear and may result in engine seizure, accident and injury. Always perform the maintenance procedures as outlined in the Periodic Maintenance Chart. Failure to perform routine maintenance could result in voiding of remaining warranty.

## ENGINE

### Adjusting the valve clearance

**NOTE:**

- The valve clearance must be adjusted when the engine is cool to the touch.
  - Adjust the valve clearance when the piston is at the Top Dead Center (TDC) on the compression stroke.
- 

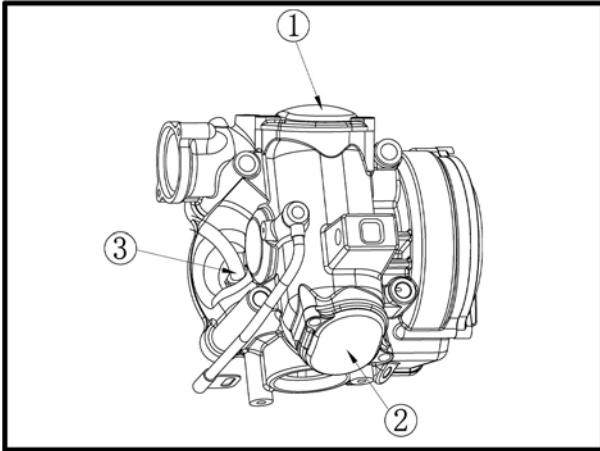

1. Remove following parts:

- ① Valve cover
- ② Valve cover
- ③ spark plug cap
- ④ spark plug

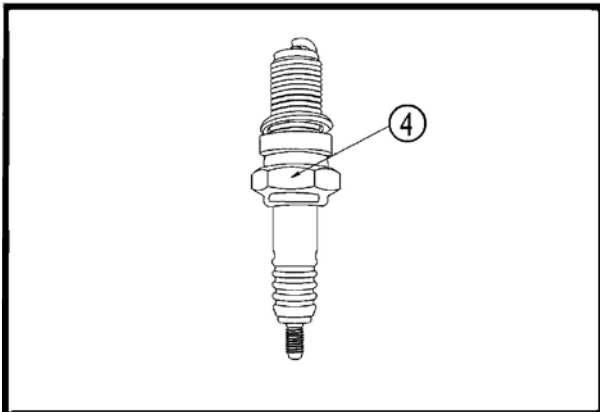

2. Remove the cooling fan:

- ① Fan cover

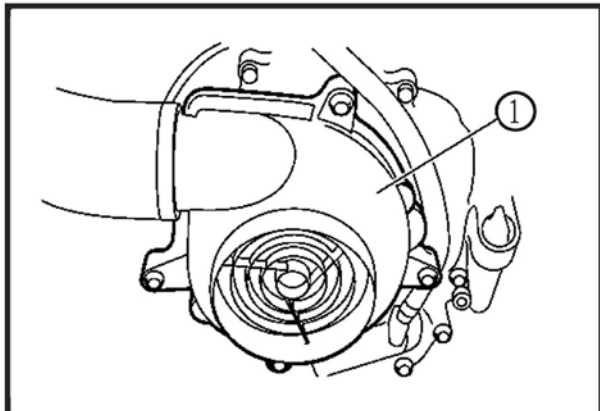

## MAINTENANCE AND ADJUSTMENT OF THE UTV

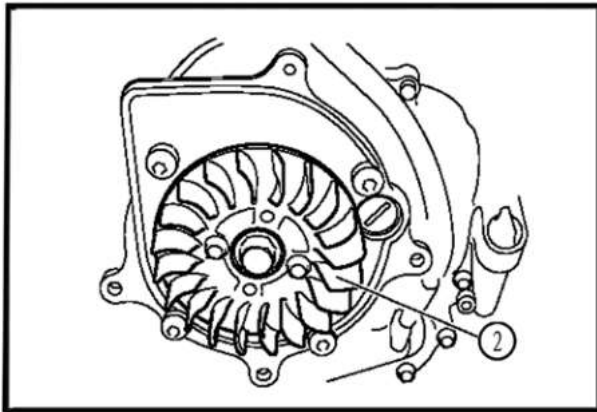

② Fan impeller

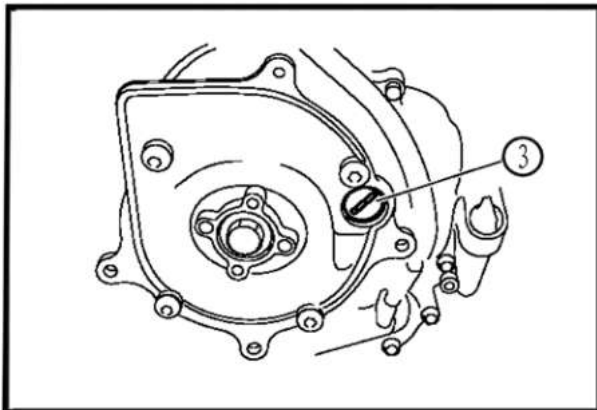

③ As manhole covers

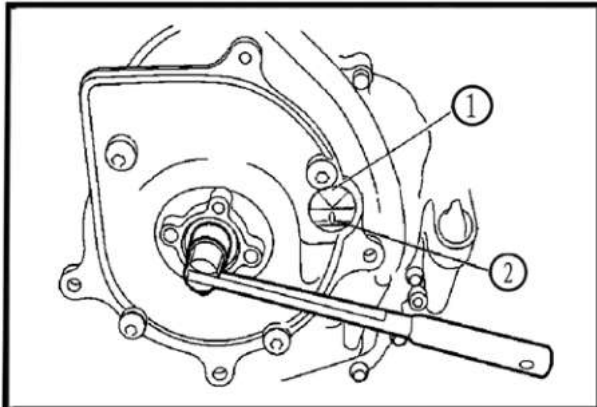

### 3. calibration

- Wrench to counterclockwise rotation crankshaft
- According to the rotor turning counterclockwise, rotor turn to mark the dead spots ② of crank box, namely ①: the dead point position is compressed.

### 4. Check:

- valve clearance
- Beyond the standard → Adjust.

#### Valve clearance (cold)

##### Intake

**0.10 ~ 0.15 mm**  
(0.0039 ~ 0.0059 in)

##### Exhaust

**0.15 ~ 0.20 mm**  
(0.0059 ~ 0.0079 in)

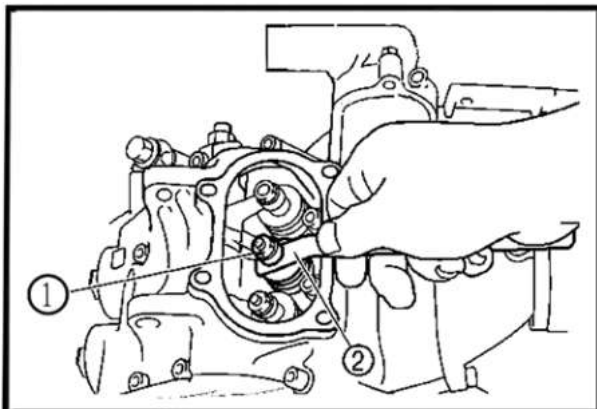

### 5. Adjust:

valve clearance

- ① Lock nut
- ② Valve thickness gauge (gap Regulation)

## MAINTENANCE AND ADJUSTMENT OF THE UTV

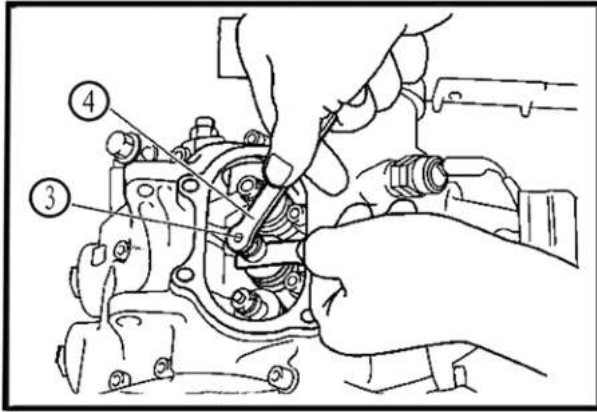

③ Regulator

④ Adjust tools

- Loosen the locknut ①.
- Insert a thickness gauge ③ between the adjuster end and the valve end.
- Turn the adjuster ③ clockwise or counterclockwise with the tappet adjusting tool proper clearance is obtained.
- In order to avoid the regulator, adjust rotation together after fastening tool fixed lock nut.

**14Nm (1.4kg.m)**

- Measuring clearance rules with the valve clearance.
- If the gap beyond the standard value, repeat the above steps until the correct gap.

6. Install all removed parts

According to remove the reverse order for installation

- ① Engine fan components
- ② Fan cover
- ③ spark plug
- ④ Valve cover (exhaust)
- ⑤ Valve cover (intake)
- ⑥ Lower the cargo bed.
- ⑦ console
- ⑧ seat

Refer to "SEATS," in chapter 5.

### IDLE ADJUSTMENT

1. Starting engines, thorough warm machine

2. Remove:

- Lift the cargo bed up.
- seat
- console

Refer to "SEATS " in chapter 5.

3. Install

- Engine tachometer

4. Confirm speed

- Standard Engine Idle speed

**Engine idle speed**  
**1,500 ±150 r/min**

Beyond the standard → Adjust.

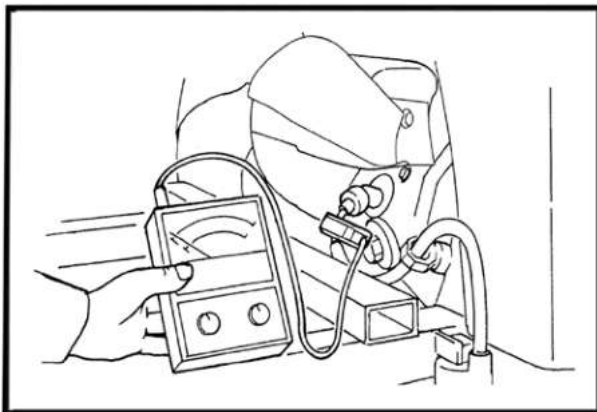

## MAINTENANCE AND ADJUSTMENT OF THE UTV

5. Adjust:

- Engines idle speed adjustment
  - a. Turn the throttle stop screw in or out until the specified idle speed is obtained.

**NOTE:**

**Don't lock screw too tight**

Turning in	Idle speed becomes higher.
Turning out	Idle speed becomes lower.

6. sever:

- Tachometer

7. Lower the cargo bed.

8. Install:

- console
- seat

### ADJUSTING THE THROTTLE CABLE

**NOTE:**

**Throttle cable free play should be adjusted properly before adjusting the engine idle speed.**

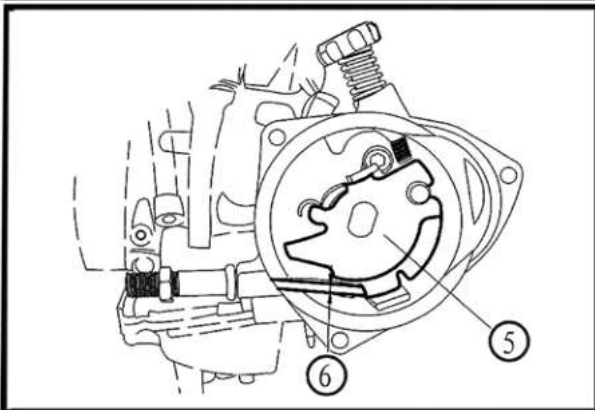
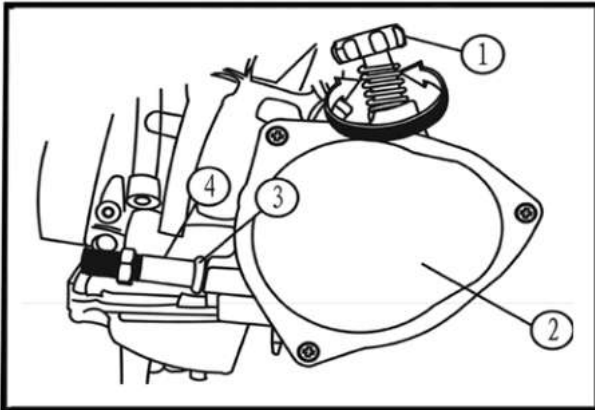

- ① Idle adjusting lever
- ② External shaft cover
- ③ Throttle Cable Solenoid
- ④ Adjusting Screw
- ⑤ Throttle Valves
- ⑥ Throttle Cable

1. Remove following parts:

- driver seat
- passenger seat
- console

2. Remove:

- Throttle valve cover ②

3. Check:

- throttle cable Slack ⑥ → Remove the slack

4. Adjust:

- throttle cable

- a. Will loosen the locknut ①.
- b. Adjusted by regulator

## MAINTENANCE AND ADJUSTMENT OF THE UTV

Turning in	Slack is increased.
Turning out	Slack is decreased.

c. Tighten the locknut.

### **NOTE:**

After adjustment throttle pressure on the accelerator cable several times, ensuring the throttle ③, then close completely loosen the accelerator pedal .

5. Install:

- console
- passenger seat
- driver seat

### **CHECKING THE SPARK PLUG**

1. Lift the cargo bed up.
2. Remove:
  - pull out the spark plug cap ① and remove the spark plug by sleeve
3. Check:
  - spark plug type
 Incorrect → Replace.

**Standard spark plug  
DR8EA/NGK**

4. Check:
  - electrode ①  
To check if it is burned blunt or much carbon is there, then check the pole clearance by thickness gauge. It is qualified if the pole clearance is between 0.6 to 0.7mm. Otherwise it should be adjusted.  
Wear/damage → Replace.
  - insulator ②  
Abnormal color → Replace.  
Normal color is a medium-to-light tan color.
5. Clean the spark plug with a spark plug cleaner or wire brush.
6. Install:
  - spark plug

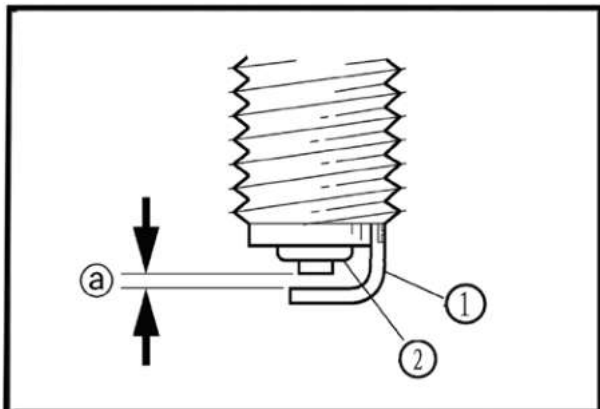
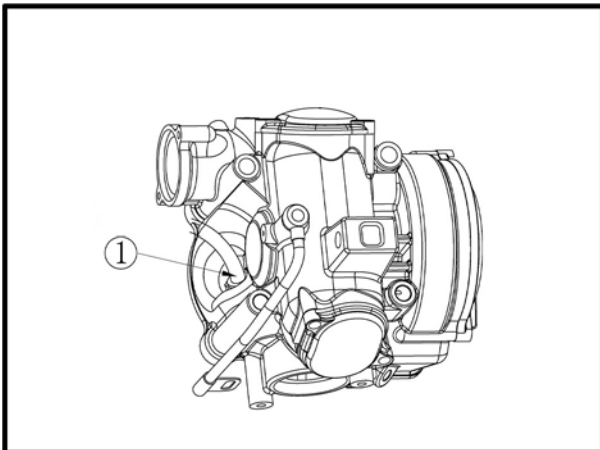



## MAINTENANCE AND ADJUSTMENT OF THE UTV

18 Nm -20 Nm (1.8 m · kg, 13 ft · lb)

Then hook up the spark plug cap.

### **NOTE:**

**Before installing a spark plug, clean the gasket surface and plug surface.**

7. Lower the cargo bed.

### CHECKING THE IGNITION TIMING

#### **NOTE:**

**Engine idle speed and throttle cable free play should be adjusted properly before checking the ignition timing.**

1. Remove:

- seat
- console

Refer to "SEATS" in chapter 5.

2. Lift the cargo bed up.

3. Attach:

- tachometer
- timing light  
(to the spark plug lead)

4. Remove:

Remove the cooling fan  
reference of adjusting valve clearance.

5. Check:

- ignition timing

a. Warm up the engine and keep it at the specified speed

#### **Engine speed**

**1,400 ~ 1,500 r/min**

b. Remove the timing plug ③

c. Visually check the stationary pointer ① to verify it is within the required firing range ② indicated on the flywheel.

Incorrect firing range → Check the pulser coil assembly.

d. Install the timing plug.

6. Install:

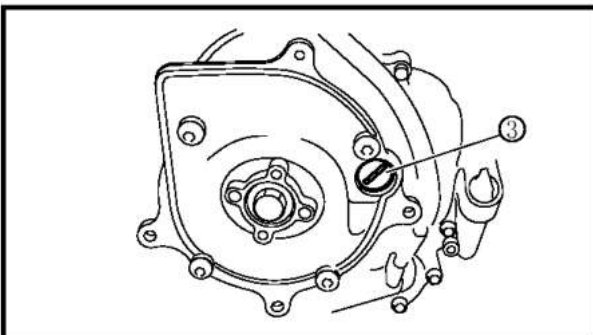
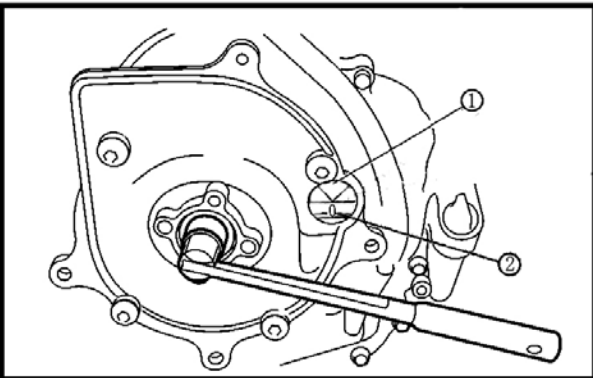
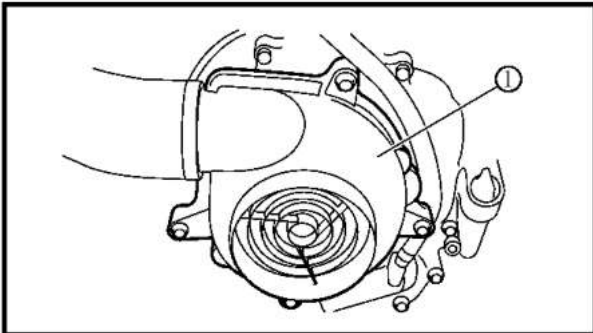

## MAINTENANCE AND ADJUSTMENT OF THE UTV

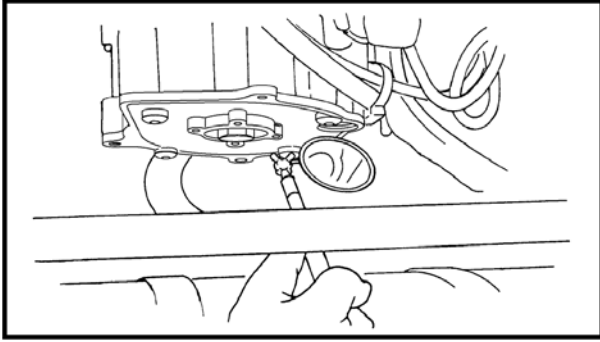

- Engine cooling fan

**7 Nm (0.7 m · kg, 5.1 ft · lb)**

7. Install:

- ① Air shroud

**10 Nm (1.0 m · kg, 7.2 ft · lb)**

8. Detach:

- timing light
- tachometer

9. Lower the cargo bed.

10. Install:

- console
- seat

Refer to “SEATS” in chapter 5.

### MEASURING THE COMPRESSION PRESSURE

#### **NOTE:**

**Insufficient compression pressure will result in a loss of performance.**

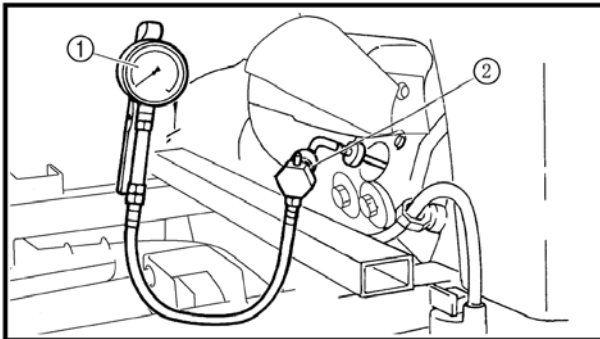

1. Start the engine and let it warm up for several minutes.
2. Stop the engine and remove the spark plug.
3. Assemble the compression pressure meter ① and joint utensil ② on the hole of the spark plug
4. check standard value

**standard compression pressure data**  
**1200Kpa (12kg/ cm<sup>2</sup>)-1000r/min**

5. read the highest data on the compression pressure meter
  - Above the maximum pressure:  
Check the cylinder head, valve surfaces, and piston crown for carbon deposits.
  - Below the minimum pressure:  
Check the accumulation carbon in the firebox of the cylinder head and accumulation carbon on the piston head.
  - Refer to the table below.

## MAINTENANCE AND ADJUSTMENT OF THE UTV

---

Compression pressure(with oil introduced into cylinder)	
Reading	Diagnosis
Higher than without oil	Worn or damaged pistons
Same as without oil	Defective ring(s), valves, cylinder head gasket or piston is possible.

<b>Compression pressure (at sea level)</b> <b>Standard: 1,324Kpa (13.24 kg/cm<sup>2</sup>, 188.31Psi)</b> <b>Minimum: 1,150Kpa (11.5 kg/cm<sup>2</sup>, 163.57Psi)</b> <b>Maximum: 1,480Kpa (14.8 kg/cm<sup>2</sup>, 210.50Psi)</b>
--

- Crank over the engine with the electric starter (be sure the battery is fully charged) with the throttle wide-open until the compression reading on the gauge stabilizes.

### **NOTE:**

**When cranking the engine, ground the spark plug lead to prevent sparking.**

---

4. Install:
  - spark plug

<b>18 Nm-20Nm (1.8 m · kg, 13 ft · lb)</b>
--

5. Lower the cargo bed.

### **CHECKING THE ENGINE OIL LEVEL**

1. Place the vehicle on a level surface
2. Remove:
  - seat
  - consoleRefer to “SEATS” in chapter 5.
3. Check:
  - engine oil levelOil level should be between the maximum

## MAINTENANCE AND ADJUSTMENT OF THE UTV

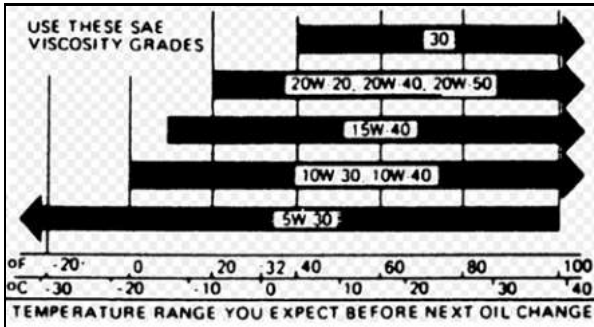
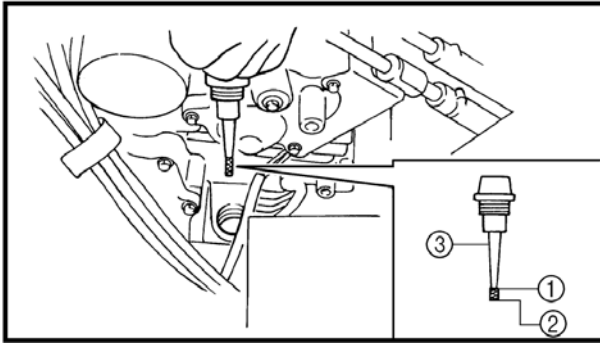

① and minimum ② marks.

Oil level low → Add oil to the proper level.

### NOTE:

Do not screw the dipstick 3 in when checking the oil level.

### Recommended oil

Follow the left chart.

### NOTE:

Recommended oil classification:

API-SJ & JASO/MA

### NOTE:

Do not allow foreign material to enter the crankcase.

4. Start the engine and let it warm up for several
5. Stop the engine and check the oil level again.

### NOTE:

Wait a few minutes until the oil settles before checking the oil level.

### NOTE:

Never remove the dipstick just after high speed operation because the heated oil could spurt out. Wait until the oil cools down before removing the dipstick.

6. Install:

- console
- seat

Refer to "SEATS" in chapter 5.

### CHANGING THE ENGINE OIL

Place the vehicle on a level surface.

1. Start the engine and let it warm up for several minutes.
2. Stop the engine and place an oil pan under

## MAINTENANCE AND ADJUSTMENT OF THE UTV

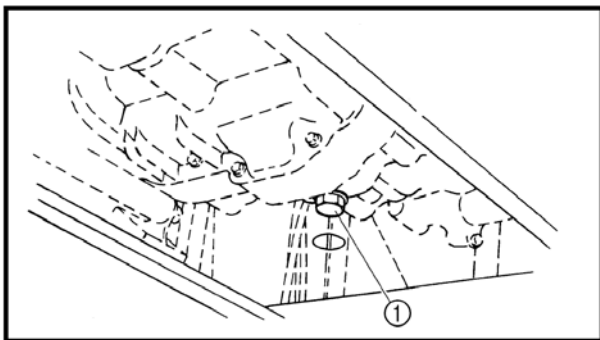
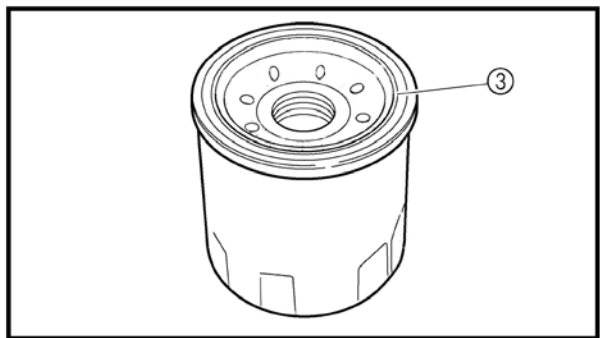
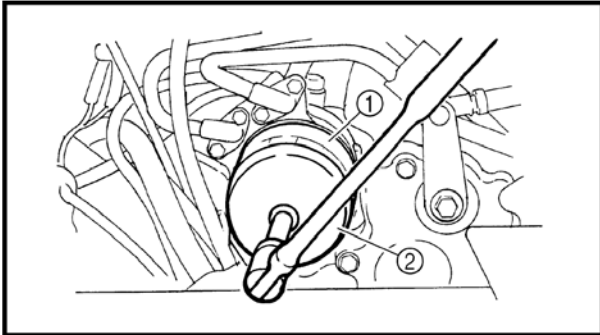
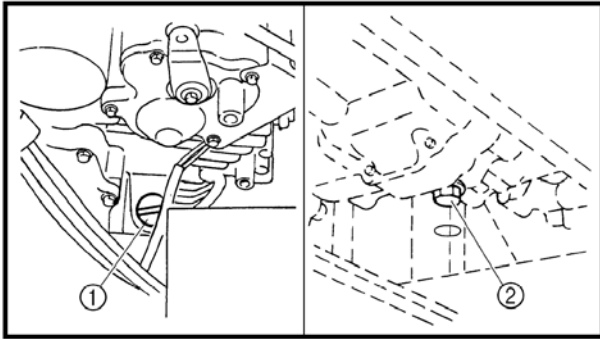

the engine.

3. Remove:

- seat
- console

4. Remove:

- engine oil filler plug (dipstick) ①
- engine oil drain bolt ② Drain the engine oil from the crankcase.

5. If the oil filter cartridge is also to be replaced, perform the following procedure.

- Remove the oil filter cartridge ① With an oil filter wrench ②.

- Lubricate the O-ring cartridge with a thin coat of lithium-soap-based grease.

### **NOTE:**

**Make sure that the O-ring ③ is positioned correctly in the groove of the oil filter cartridge.**

- Tighten the new oil filter cartridge to specification with an oil filter wrench.

### **Oil filter cartridge**

**17 Nm (1.7 m · kg, 12 ft · lb)**

6. Install:

- engine oil drain bolt ①

7. Fill:

- Before the oil is put into the crankcase, please cleanout oil filter and make it in good working condition, then assemble.
- crankcase (with sufficient oil to reach the specified level)

## MAINTENANCE AND ADJUSTMENT OF THE UTV

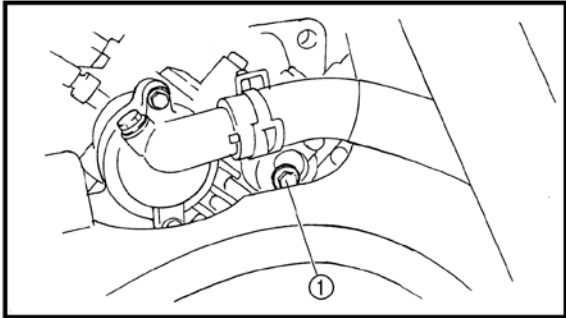

### Oil quantity

#### Periodic oil change

The oil capacity after the engine is disassembled and reassembled.

**1.9L**

The oil should be put into the engine for after all the oil is drawn out

**1.8L**

8. Install:
  - engine oil filler plug
9. Warm up the engine for a few minutes, then stop the engine.
10. Check:
  - engine (for engine oil leaks)
  - oil level Refer to “THE ENGINE “ in chapter 4 .
11. Check:
  - engine oil pressure
- a. Slightly loosen the oil gallery bolt ①.
- b. Start the engine and keep it idling until engine oil starts to seep from the oil gallery bolt. If no engine oil comes out after one minute, turn the engine off so that it will not seize.
- c. Check the engine oil passages, the oil filter cartridge and the oil pump for damage or leakage. Refer to “THE ENGINE” in chapter 4.
- d. Start the engine after solving the problem(s) and check the engine oil pressure again.
- e. Tighten the oil gallery bolt to specification.

### Oil gallery bolt

**7 Nm (0.7 m · kg, 5.1 ft · lb)**

12. Install:
    - console
    - seat
- Refer to “SEATS” in chapter 5.

## CHASSIS

### CLEANING THE AIR FILTER

**NOTE:**

There is a check hose ① at the bottom of the air filter case. If dust and/or water collect in this hose, clean the air filter element and air filter case.

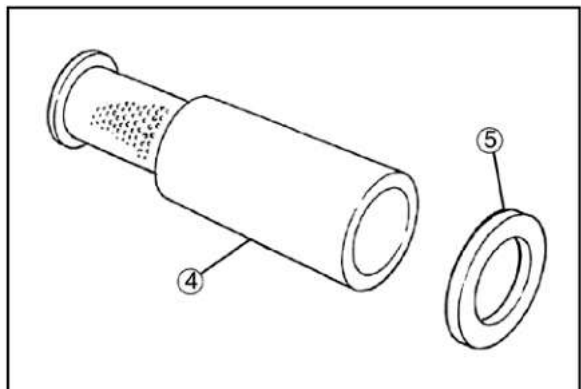
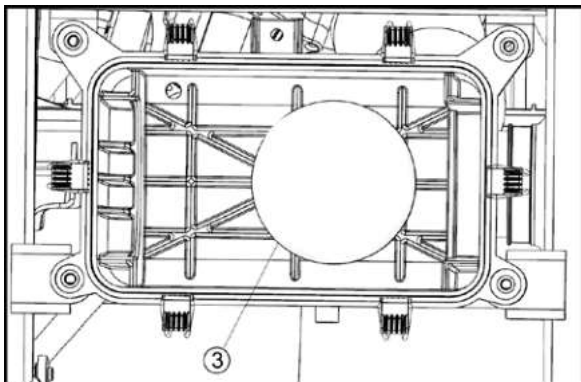
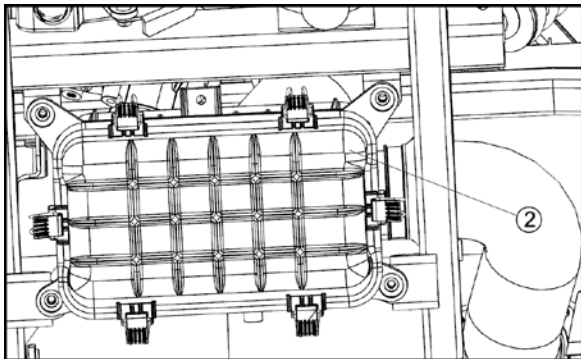
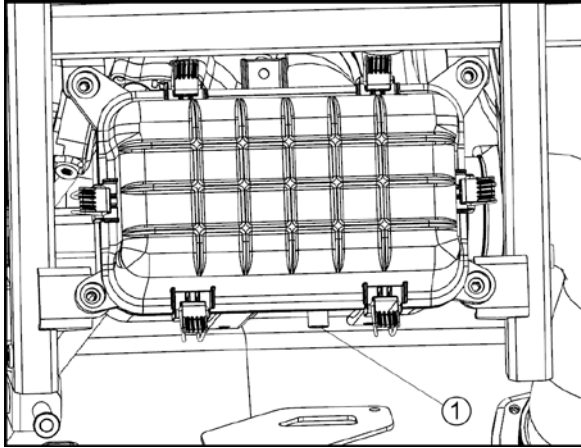

1. Remove: •

- Front faceplate ①
- air filter case cover ②
- air filter element assembly③
- air filter element④
- Element retaining plat⑤

**NOTE:**

Never operate the engine with the air filter element removed. This will allow unfiltered air to enter, causing rapid wear and possible engine damage. Additionally, operation without the filter element will affect carburetor tuning with subsequent poor performance and possible engine overheating.

2. Check:

- air filter element④
- Damaged → Replace.

3. Clean:

- air filter element

a. Wash the element gently, but thoroughly in solvent.

## MAINTENANCE AND ADJUSTMENT OF THE UTV

---

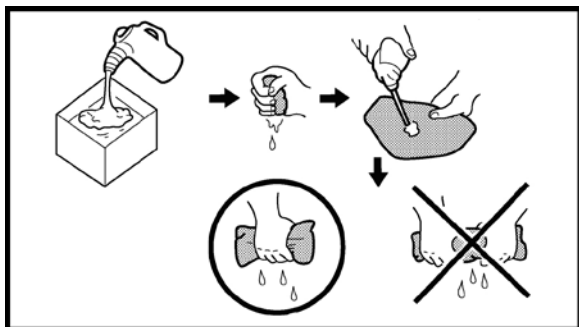

---

**WARNING:**

*Use a cleaning solvent which is designed to clean parts only. Never use gasoline or low flash point solvents as they may cause a fire or explosion.*

---

b. squeeze the excess solvent out of the element and let it dry.

---

**NOTE:**

**Do not twist or wring out the element. This could damage the foam material.**

---

c. Squeeze out the excess oil.

---

**NOTE:**

**The element should be wet but not dripping.**

---

4. Install:

- air filter element
- air filter case cover

---

**NOTE:**

**To prevent air leaks make sure that the sealing surface of the element matches the sealing surface of the case.**

---

- console
- seat

### CHECKING THE COOLANT LEVEL

1. Place the vehicle on a level surface.
2. Remove front faceplate
3. Check:
  - start the engine, warm it up for several minutes, and then turn it off.
  - coolant level

---

**NOTE:**

**Before checking the coolant level, wait a few minutes until the coolant has settled.**

---



## MAINTENANCE AND ADJUSTMENT OF THE UTV

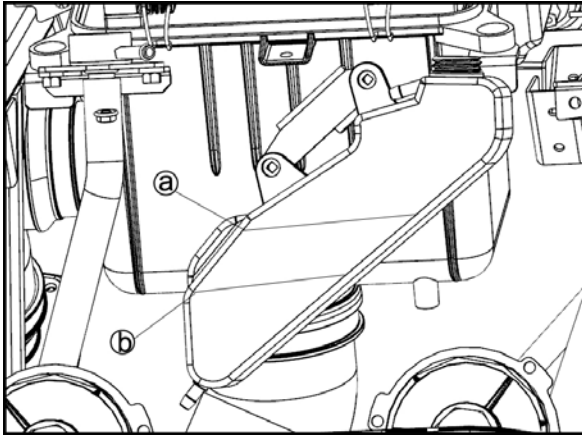

- coolant level
- The coolant level should be between the minimum level mark ① and maximum level mark ②. Below the minimum level mark → Add the recommended coolant to the proper level.

### CHANGING THE COOLANT

1. Remove:

Front faceplate

- coolant reservoir cap ①
- Disconnect coolant reservoir hose ②
- Adding water instead of coolant lowers the antifreeze content of the coolant. If water is used instead of coolant, check and if necessary, correct the antifreeze concentration of the coolant;
- Use only distilled water. However, soft water may be used if distilled water is not available.

2. Drain:

- coolant  
(from the coolant reservoir)

3. Connect:

- coolant reservoir hose

4. Remove:

- coolant drain bolt (water pump)  
copper washer)

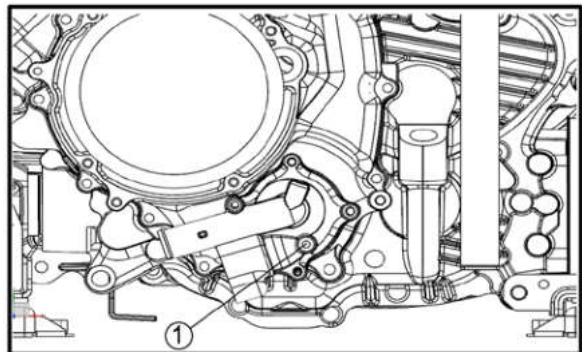
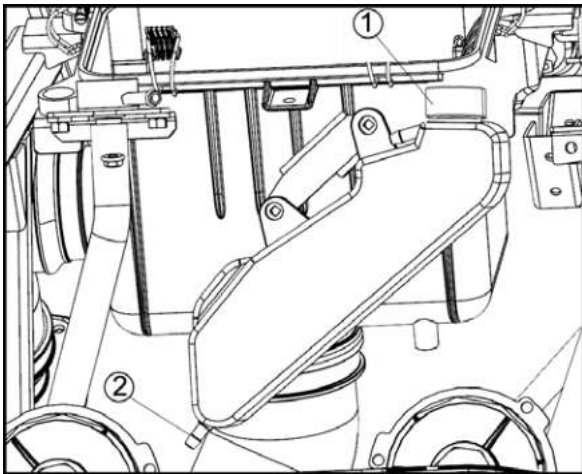

## MAINTENANCE AND ADJUSTMENT OF THE UTV

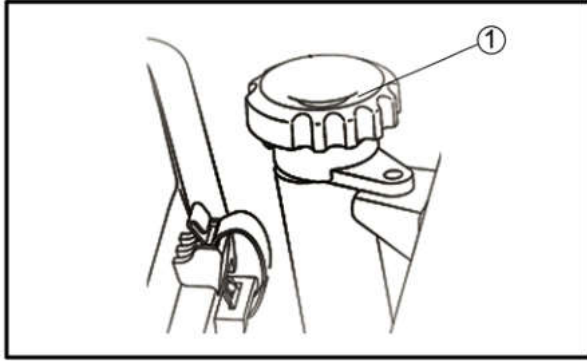

5. Remove:

- radiator cap ①

**WARNING:**

*A hot radiator is under pressure. Therefore, do not remove the radiator cap when the engine is hot. Scalding hot fluid and steam may be blown out, which could cause serious injury. When the engine has cooled, open the radiator cap as follows: Place a thick rag or a towel over the radiator cap and slowly turn the radiator cap counterclockwise toward the detent to allow any residual pressure to escape.*

*When the hissing sound has stopped, turn the radiator cap counterclockwise while pressing down on it and then remove it.*

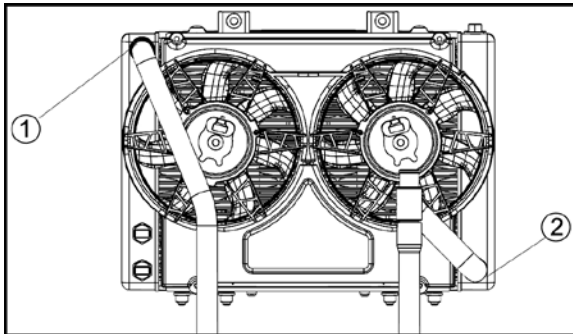

6. Drain:

- coolant

7. Disconnect:

- coolant outlet hose ①
- water pump inlet hose ②

8. Drain:

- coolant

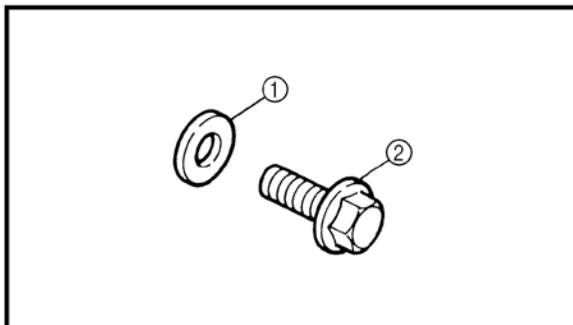

9. Check:

- copper washer ①
  - coolant drain bolt ②
- Damage → Replace.

10. Install:

- coolant drain bolt (water pump) T R.

**10 Nm (1.0 m · kg, 7.2 ft · lb)**

11. Connect:

- water pump inlet hose
- coolant outlet hose

## MAINTENANCE AND ADJUSTMENT OF THE UTV

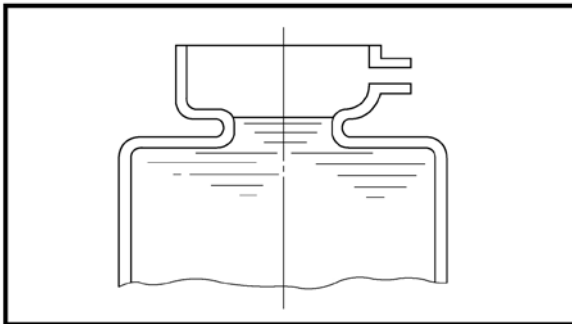
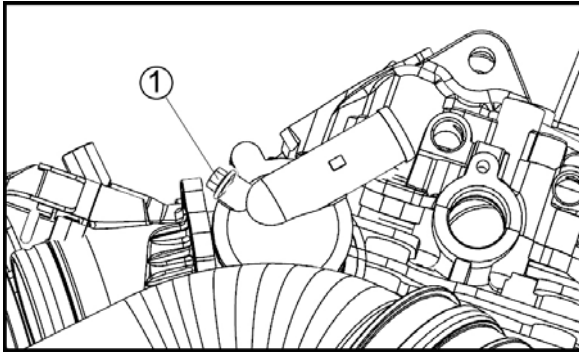

12. Remove:

- air bleed bolt ①

13. Fill cooling

(with the specified amount of the recommended coolant)

### Recommended antifreeze

High-quality ethylene glycol antifreeze containing corrosion inhibitors for aluminum engines

### Mixing ratio

1 : 1 (antifreeze : water)

### Quantity total amount

1.32 L

### Coolant reservoir capacity

0.627 L

### NOTE:

The specified amount of coolant is a standard amount. Fill the cooling system with coolant until coolant comes out of the hole for the air bleed bolt.

Coolant is potentially harmful and should be handled with special care.

### WARNING:

- *If coolant splashes in your eyes, thoroughly wash them with water and consult a doctor;*
- *If coolant splashes on your clothes, quickly wash it away with water and then with soap and water;*
- *If coolant is swallowed, induce vomiting and get immediate medical attention;*
- *If coolant comes into contact with painted surfaces, immediately wash them with water;*
- *Do not mix different types of antifreeze.*

## MAINTENANCE AND ADJUSTMENT OF THE UTV

---

### NOTE:

Adding water instead of coolant lowers the antifreeze content of the coolant. If water is used instead of coolant, check, and if necessary, correct the antifreeze concentration of the coolant. Use only distilled water. However, soft water may be used if distilled water is not available.

---

14. Install:

- air bleed bolt

**9 Nm (0.9 m · kg, 6.5 ft · lb)**

- radiator cap;
- Fill coolant reservoir;
- Install coolant reservoir cap:
- Start the engine, warm it up for several minutes, and then turn it off.
- Check:  
coolant level

Refer to “THE COOLANT” in chapter 4.

### NOTE:

Before checking the coolant level, wait a few minutes until the coolant has settled.

---

- Close the hood.
- Install driver seat

Refer to “SEATS,” in chapter 5.

### CHECKING THE COOLANT TEMPERATURE WARNING LIGHT

Coolant temperature indicator light ①

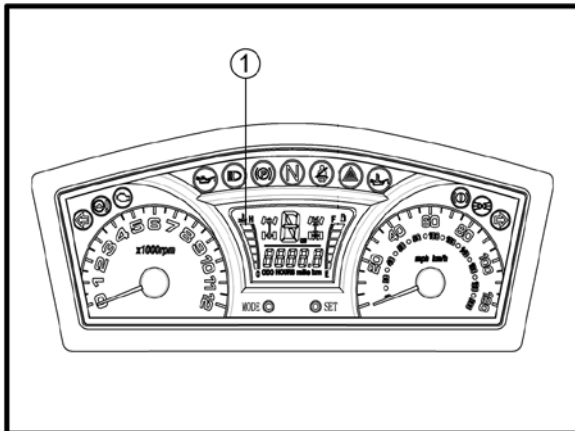

# MAINTENANCE AND ADJUSTMENT OF THE UTV

## Coolant temperature warning light checking method

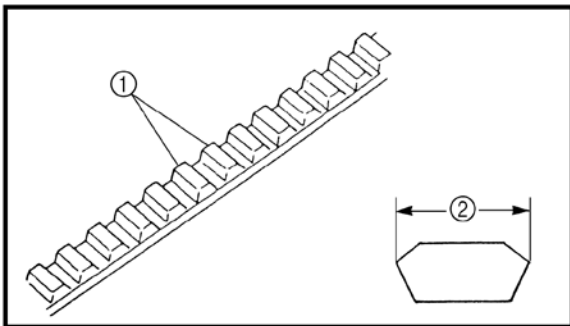
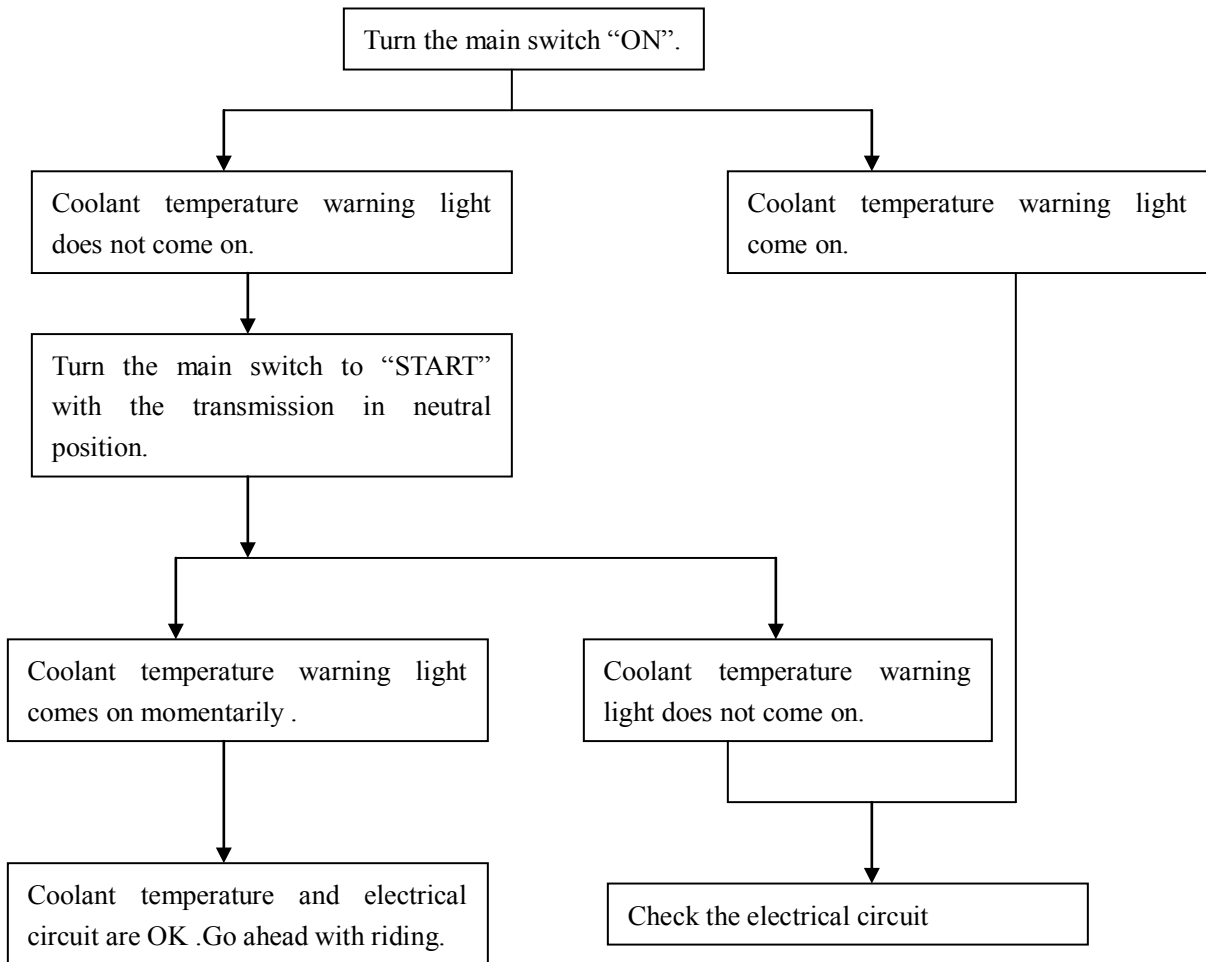

## CHECKING THE V-BELT

### 1. Remove:

- driver seat
- drive belt cover
- Check:

#### a. V-belt ①

Cracks/wear/scaling/chipping → Replace.

Oil/ grease → Check primary sheave and secondary sheave.

#### b. V-belt width ②

Out of specification → Replace.

## MAINTENANCE AND ADJUSTMENT OF THE UTV

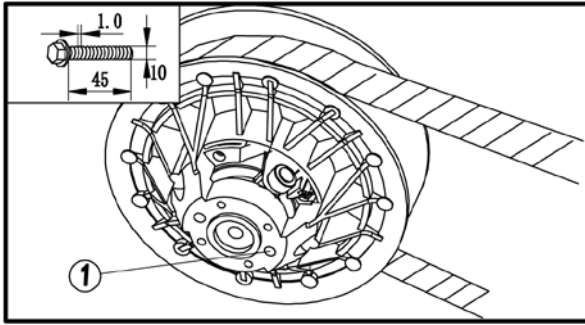

**V-belt width: 31.2 mm**  
**<Limit:> 26 mm**

- Replace V-belt:  
Install the bolts ① into the secondary fixed sheave hold.

### **NOTE:**

Tightening the bolts ① will push the secondary sliding sheave away, causing the gap between the secondary fixed and sliding sheaves to widen.

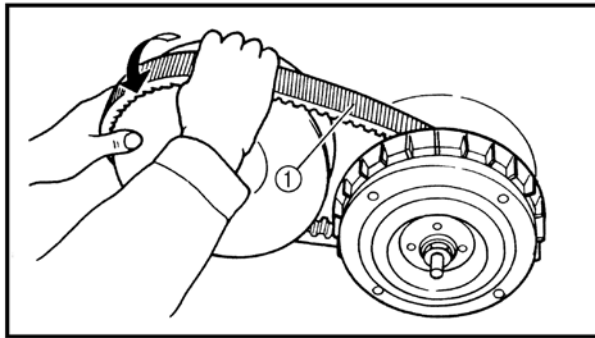

- Remove the V-belt ① from the primary sheave and secondary sheave.
- Install the V-belt.

### **NOTE:**

Install the V-belt so that its arrow faces the direction shown in the illustration.

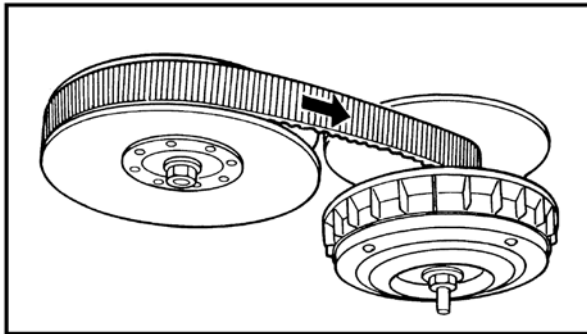

- Remove the bolts.
2. Install:
- drive belt cover
  - console
  - passenger seat
  - driver seat

### **CLEANING THE SPARK ARRESTER**

1. Clean:  
Tap the tailpipe lightly with a soft-face hammer or suitable tool, then use a wire brush to remove any carbon deposits from the spark arrester portion of the tailpipe and the inner contact surfaces of the muffler.
2. Spark arrester

## MAINTENANCE AND ADJUSTMENT OF THE UTV

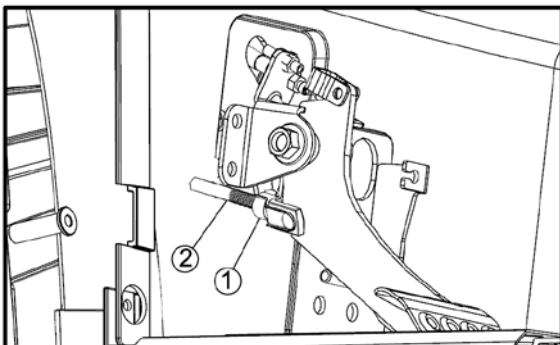
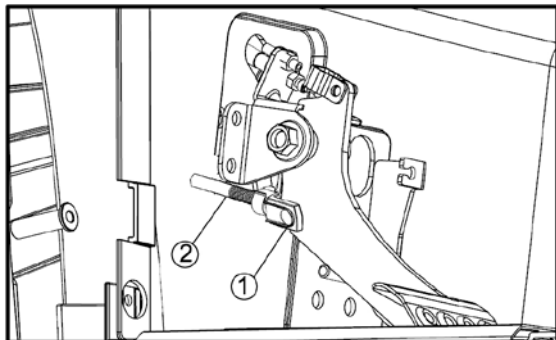
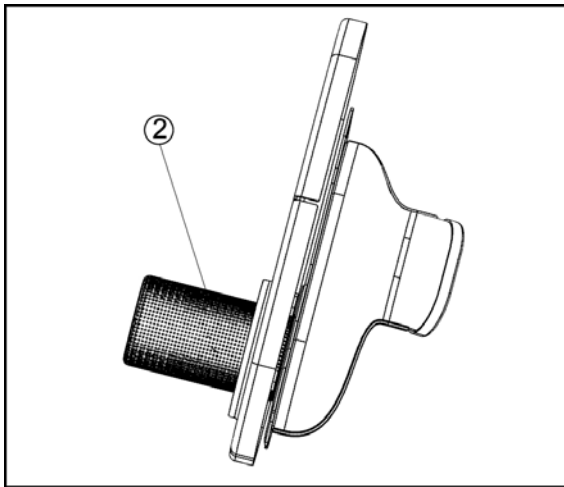
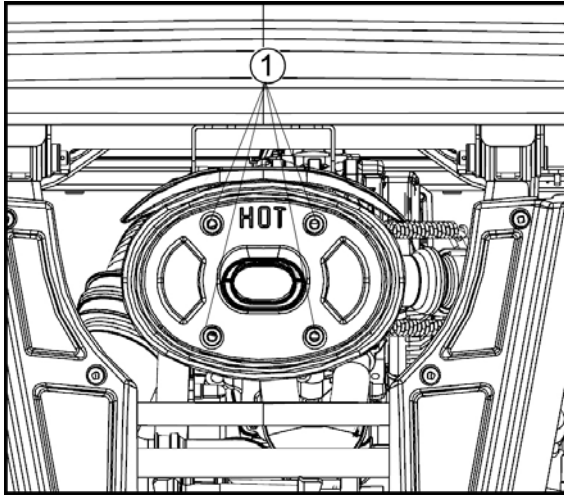

### **WARNING:**

- Select a well-ventilated area free of combustible materials.
- Always let the exhaust system cool before performing this operation.
- Do not start the engine when removing the tailpipe from the muffler.

### 3. Remove:

- Remove the bolts ①.
- Remove the tailpipe ② by pulling it out of the muffler.

### 4. Install:

- Insert the tailpipe ( ) bolt holes.
- Insert the bolt 1 and tighten it.
- Start the engine and rev it up approximately twenty times while momentarily creating exhaust system back pressure by blocking the end of the muffler with a shop towel.
- Stop the engine and allow the exhaust pipe to cool.

### ADJUSTING THE BRAKE PEDAL

#### 1. Check:

- brake pedal free play a Out of specification  
→ adjust.

### **NOTE:**

The end of the brake rod contact the brake master cylinder ②

**Brake pedal free play**  
**0 mm (0.0 in)**

#### 3. Adjust:

- brake pedal free play
- a. Loosen the locknut ①
- b. Turn brake rod ② in or out until the correct free play is obtained.

## MAINTENANCE AND ADJUSTMENT OF THE UTV

Turning in	Free play is increased.
Turning out	Free play is decreased.

c. Tighten the locknut to specification.

**Locknut**  
17 Nm (1.7 m · kg, 12 ft · lb)

### **NOTE:**

Make sure that there is no brake drag on the front or rear wheels.

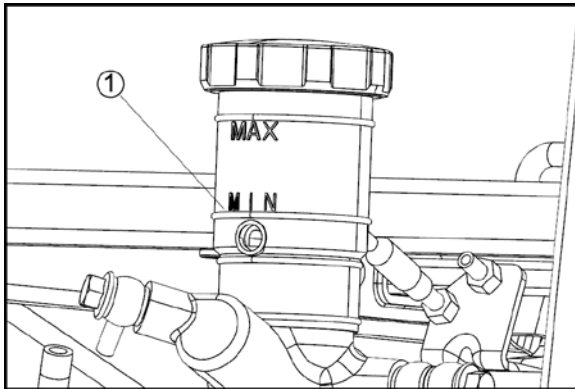

### CHECKING THE BRAKE FLUID LEVEL

1. Place the vehicle on a level surface.

### **NOTE:**

When checking the brake fluid level, make sure that the top of the brake fluid reservoir top is horizontal.

2. Lift the hood up.

3. Check:

- brake fluid level Fluid level is under “MIN” ① line → Fill up.

### **NOTE:**

Brake fluid may erode painted surfaces or plastic parts. Always clean up spilled fluid immediately.

### **WARNING:**

- *Use only the designed quality brake fluid: otherwise, the rubber seals may deteriorate, causing leakage and poor brake performance.*
- *Refill with the same type of brake fluid: mixing fluids may result in a harmful chemical reaction and lead to poor performance.*
- *Be careful that water does not enter the master cylinder when refilling. Water will significantly lower the boiling point of the fluid and may result in a vapor lock.*

4. Close the hood.



## MAINTENANCE AND ADJUSTMENT OF THE UTV

### CHECKING THE FRONT BRAKE PADS

1. Remove:
  - front wheels
2. Check:
  - brake pads Wear indicator groove  $\text{\textcircled{a}}$  almost disappearedReplace the brake pads as a set.  
Refer to "FRONT AND REAR BRAKES" in chapter 5.

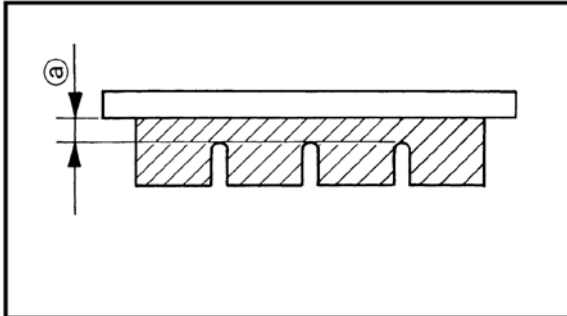

**Brake pad wear limit  $\text{\textcircled{a}}$   
1.5 mm (0.06 in)**

3. Operate the brake pedal.
4. Install:
  - front wheels

### CHECKING THE REAR BRAKE PADS

1. Check:
  - brake padsWear indicator groove  $\text{\textcircled{a}}$  almost disappeared  
Replace the brake pads as a set.  
Refer to "FRONT AND REAR BRAKES" in chapter 5.

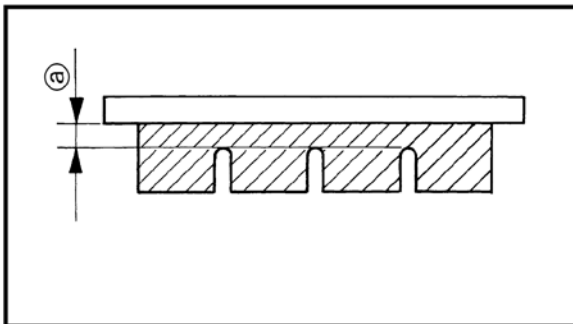

**Brake pad wear limit  $\text{\textcircled{a}}$   
1.5 mm (0.06 in)**

3. Operate the brake pedal.

## MAINTENANCE AND ADJUSTMENT OF THE UTV

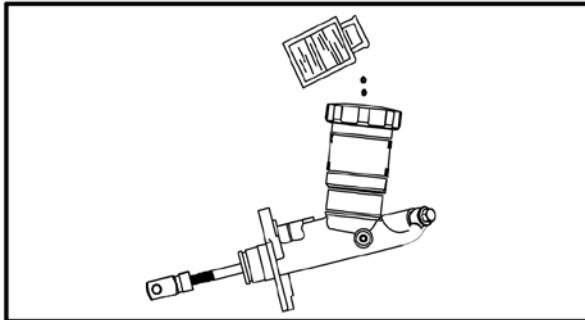
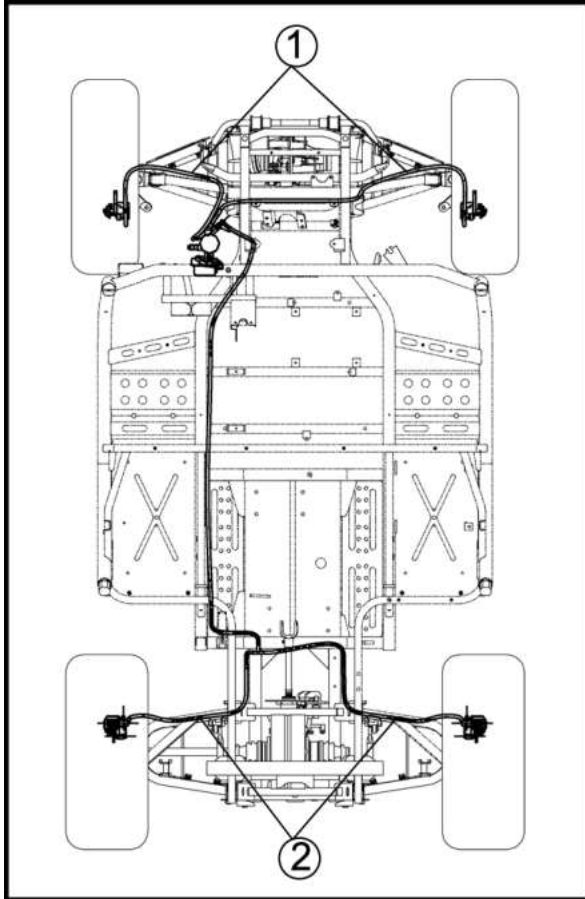

### CHECKING THE BRAKE HOSES AND BRAKE PIPES

1. Remove:
  - driver seat  
Refer to “SEATS” in chapter 5.
2. Lift the hood up.
3. Check:
  - front brake hoses ①
  - rear brake hoses ②

Cracks/wear/damage → Replace.

Fluid leakage → Replace all damaged parts.

Refer to “FRONT AND REAR BRAKES” in chapter 5.

#### **NOTE:**

Hold the vehicle in an upright position and apply the brake pedal.

4. Install driver seat

### BLEEDING THE HYDRAULIC BRAKE SYSTEM

#### **WARNING:**

*Bleed the brake system if:*

- *The system has been disassembled.*
  - *A brake hose or brake pipe have been loosened or removed.*
  - *The brake fluid has been very low.*
- The brake operation has been faulty. A loss of braking performance may occur if the brake system is not properly bled.*

1. Bleed:
  - brake system
- a. Add the proper brake fluid to the reservoir.
- b. Install the diaphragm. Be careful not to spill any fluid or allow the reservoir to overflow.
- c. Remove the cover of the brake oil pump ① add the moderate brake liquid.
- d. Place the other end of the hose into a container.
- e. Slowly apply the brake pedal several times.
- f. Push down on the pedal and hold it.
- g. Loosen the bleed screw and allow the pedal to

## MAINTENANCE AND ADJUSTMENT OF THE UTV

travel towards its limit.

- h. Tighten the bleed screw when the pedal limit has been reached, then release the pedal.
- i. Repeat steps (e) to (h) until all the air bubbles have disappeared from the fluid.
- j. Tighten the bleed screw.

**Front brake caliper bleed screw**

**6 Nm (0.6 m · kg, 4.3 ft · lb)**

**Rear brake caliper bleed screw**

**5 Nm (0.5 m · kg, 3.6 ft · lb)**

### **NOTE:**

If bleeding is difficult, it may be necessary to let the brake fluid settle for a few hours.

Repeat the bleeding procedure when the tiny bubbles in the system have disappeared.

- k. Add brake fluid to the proper level.

### **WARNING:**

*Check the operation of the brake after bleeding the brake system.*

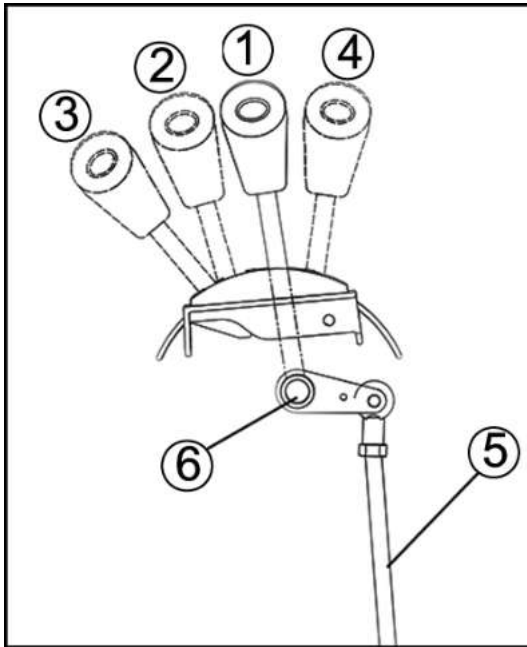

### ADJUSTING THE SELECT LEVER SHIFT ROD (BENCH)

- ① Neutral
- ② High
- ③ Low
- ④ Reverse
- ⑤ Parking
- ⑥ Select lever shift rod

### **WARNING:**

*Before shifting, you must stop the vehicle and take your foot off the accelerator pedal. Otherwise, the transmission may be damaged.*

1. Adjust:

- Select lever shift rod

- A. Make sure the select lever is in NEUTRAL.

## MAINTENANCE AND ADJUSTMENT OF THE UTV

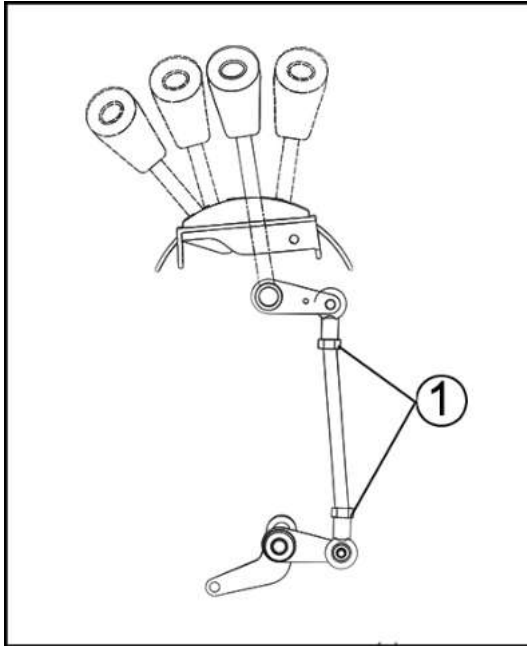

B. Lock nut ①.

### **WARNING:**

*The select lever shift rod locknut (select lever side) has left-handed threads. To loosen the locknut, turn it clockwise.*

C. Lock nut ①.

### ADJUSTING THE BRAKE LIGHT SWITCH

#### **NOTE:**

- The brake light switch is operated by movement of the brake pedal.
- The brake light switch is properly adjusted when the brake light comes on just before the braking effect starts.

1. Check

- brake light operation timing  
Incorrect → Adjust.

2. Adjust:

- brake light operation timing

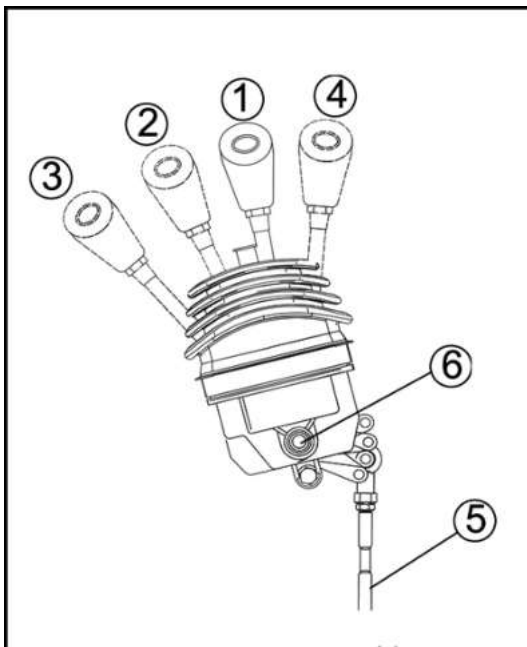

### ADJUSTING THE SELECT LEVER SHIFT ROD (BUCKET)

- ① Neutral
- ② High
- ③ Low
- ④ Reverse
- ⑤ Parking
- ⑥ Select lever shift rod

#### **WARNING:**

*Before shifting, you must stop the vehicle and take your foot off the accelerator pedal.*

*Otherwise, the transmission may be damaged.*

1. Adjust:

- Select lever shift rod

A. Make sure the select lever is in NEUTRAL.

## MAINTENANCE AND ADJUSTMENT OF THE UTV

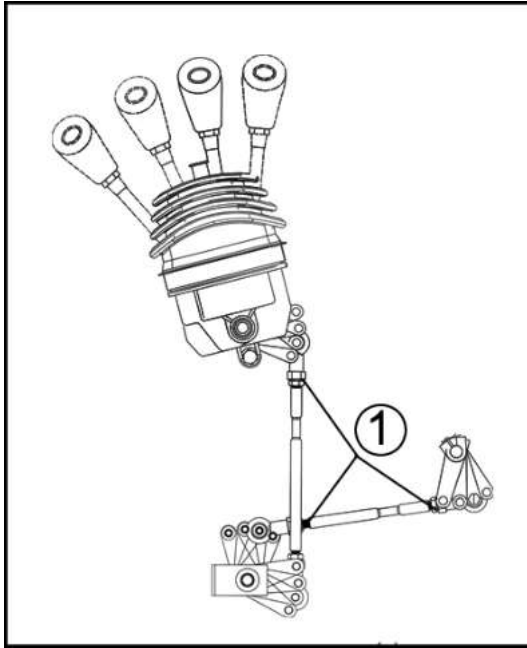

B. Lock nut ①.

**WARNING:**

*The select lever shift rod locknut (select lever side) has left-handed threads. To loosen the locknut, turn it clockwise.*

C. Lock nut ①.

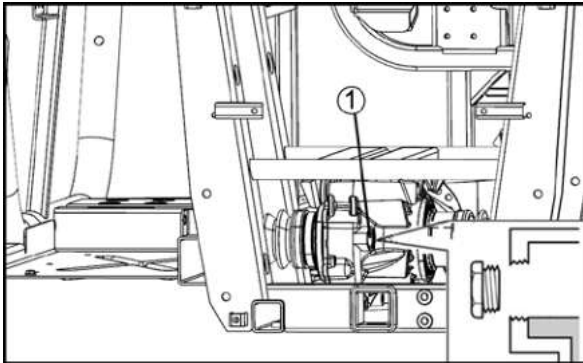

### CHECKING THE FINAL GEAR OIL LEVEL

1. Place the vehicle on a level surface.
2. Remove:
  - oil filler plug ①
3. Check:
  - oil level

Oil level should be up to the brim of the hole.  
Oil level low → Add oil to the proper level.

**Recommended oil**

**SAE 80 API GL-4Hypoid gear oil**

**WARNING:**

*Take care not allow foreign material to enter the final gear case.*

4. Install:
  - oil filler plug

**23 Nm (2.3 m · kg, 17 ft · lb)**

### CHANGING THE FINAL GEAR OIL

1. Place the vehicle on a level surface.
2. Place a container under the final gear case to collect the used oil.
3. Remove:
  - oil filler plug ①.
  - Fill:  
final gear case

## MAINTENANCE AND ADJUSTMENT OF THE UTV

---

Periodic oil change : 0.25 L (0.22 Imp qt)

Total amount :

0.4 L (0.35 Imp qt, 0.42 US qt)

### **WARNING:**

---

*Take care not to allow foreign material to enter the final gear case.*

---

- Install:  
oil filler plug

**23 Nm (2.3 m · kg, 17 ft · lb)**

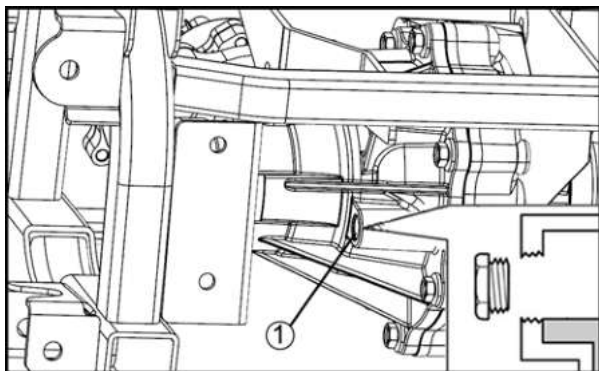

### CHECKING THE DIFFERENTIAL GEAR OIL

1. Place the vehicle on a level surface.
2. Remove:
  - oil filler plug ①
3. Check:
  - oil level

Oil level should be up to the brim of hole.  
Oil level low → Add oil to proper level.

### **WARNING:**

---

*Take care not allow foreign material to enter the differential gear case.*

---

4. Install:
  - oil filler plug

**23 Nm (2.3 m · kg, 17 ft · lb)**

### CHANGING THE DIFFERENTIAL GEAR OIL

1. Place the vehicle on a level surface.
2. Place a receptacle under the differential gear case.
3. Remove:
  - oil filler plug ①
4. Drain:
  - differential gear oil
5. Install:
  - drain plug

## MAINTENANCE AND ADJUSTMENT OF THE UTV

10 Nm (1.0 m · kg, 7.2 ft · lb)

### NOTE:

Check the gasket (drain plug). If it is damaged, replace it with new one.

6. Fill:

- differential gear case

Periodic oil change

0.32 L (0.28 Imp qt, 0.34 US qt)

Total amount

0.1 L (0.085 Imp qt, 0.105 US qt)

### NOTE:

If gear oil is filled to the brim of the oil filler hole, oil may start leaking from the differential gear case breather hose. Therefore, check the quantity of the oil, not its level.

### WARNING:

Take care not to allow foreign material to enter the differential gear case.

7. Install:

- oil filler plug

23 Nm (2.3 m · kg, 17 ft · lb)

## CHECKING THE CONSTANT VELOCITY JOINT DUST BOOTS

1. Check:

- dust boots ①

Damage → Replace.

Refer to “FRONT CONSTANT VELOCITY JOINTS,” in chapter 5.

Ⓔ Front

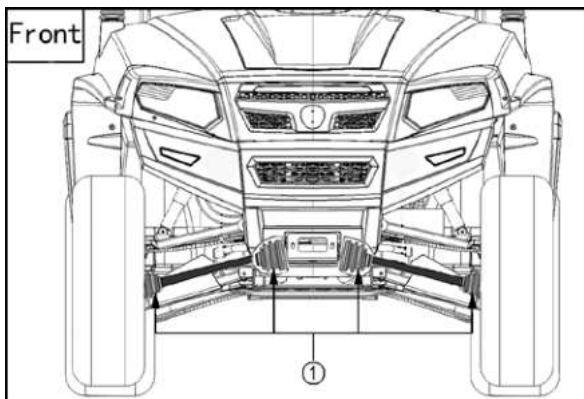

## MAINTENANCE AND ADJUSTMENT OF THE UTV

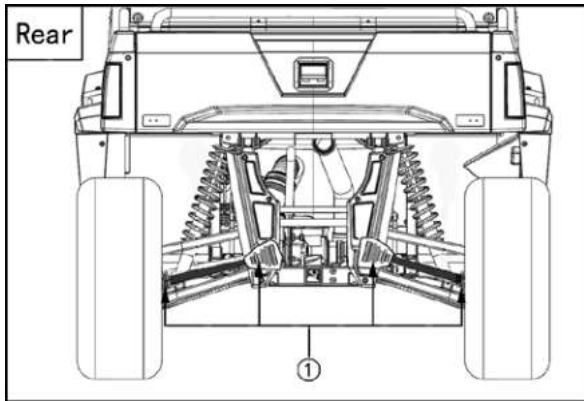

R Rear

### CHECKING THE STEERING SYSTEM

1. place the vehicle on the flat ground .

- Check:

Clamp seat of steering vertical column and sliding bearing on the lower end of steering vertical column, upper & lower and front & rear moving steering bar .If the clearance is too large, replace the sliding bearing.

Refer to section “Steering system” of chapter 5.

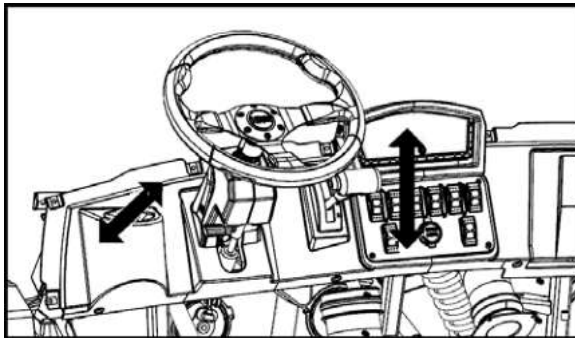

- Check:

Ball joints and/or wheel bearings Move the wheels laterally back and forth. Excessive free play → Replace the front arms (upper and lower) and/or wheel bearings.

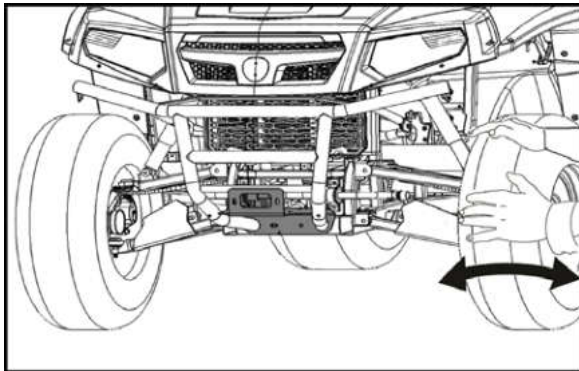



## MAINTENANCE AND ADJUSTMENT OF THE UTV

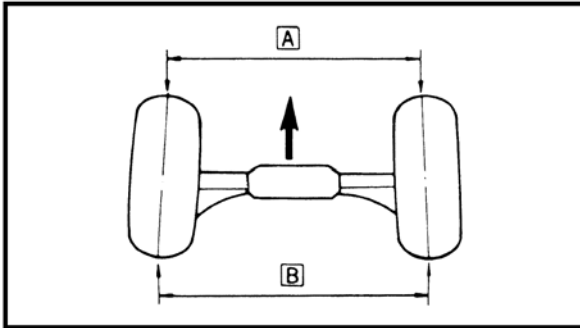
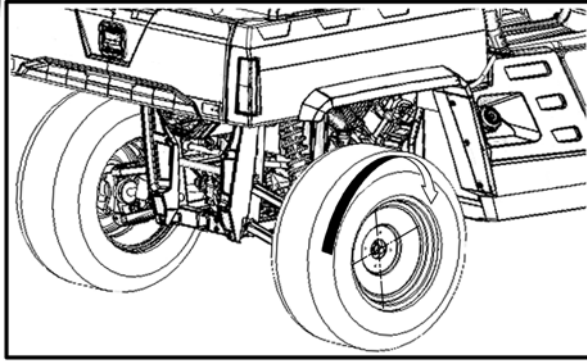

### ADJUSTING THE TOE-IN

1. Place the vehicle on a level surface.
2. Measure:
  - toe-inOut of specification → Adjust.

**Toe-in**  
8~ 18 mm (0.00 ~ 0.39 in)  
(with tires touching the ground)

#### **NOTE:**

Before measuring the toe-in, make sure that the tire pressure is correct.

- a. Mark both front tire tread centers.
- b. Lift the front end of UTV to keep the front wheel from force .
- c. Faster the steering forward . Meagre the widthe between two marks.
- d. Rotate the front tires 180° until the marks are exactly opposite one another.
- e. Measure distance **B** between the marks.
- f. Calculate the toe-in using the formula given below.

$$\text{Toe-in} = \text{B} - \text{A}$$

- g. If the toe-in is incorrect, adjust it.
3. Adjust toe-in

#### **WARNING:**

*Make sure that left / right tension rods have turned the same turns . Otherwise the UTV will still go UTV left and right even though . Operate the UTV to go forward straightly with steering bar , easily causing to getting out of contor and accident . After adjusting the toe-in correctly drive the UTV to move forward a span of distance by fastering the steering bar so as to make , sure if the Steering bar is pormal , if not , adjust the tension rod left or right within the specification .*

## MAINTENANCE AND ADJUSTMENT OF THE UTV

---

### ADJUSTING THE FRONT AND REAR SHOCK ABSORBERS

#### **WARNING:**

*These shock absorber assemblies contain highly pressurized nitrogen gas, read and understand the following information before handling the shock absorber assemblies.*

- *Do not tamper with or attempt to open the cylinder assemblies.*
  - *Do not subject the shock absorber assemblies to an open flame or other high heat source. This may cause the unit to explode due to excessive gas pressure.*
  - *Do not deform or damage the cylinders in any way. Cylinder damage will result in poor damping performance.*
  - *Do not dispose of a damaged or worn out shock absorber assembly yourself. Take the shock absorber assembly to a Bad Boy dealer for any service.*
- 

The spring preload, rebound damping and compression damping forces of the front and rear shock absorber assemblies can be adjusted to suit the operating conditions.

#### **NOTE:**

**Never turn an adjusting mechanism beyond the minimum and maximum settings.**

---

#### Spring preload

1. Loosen the locknut.
2. Turn the spring preload adjusting nut in direction (a) to increase the spring preload and thereby harden the suspension, and in direction (b) to decrease the spring preload and thereby soften the suspension.

Locknut ①  
Spring preload adjusting nut ②  
Special wrench ③

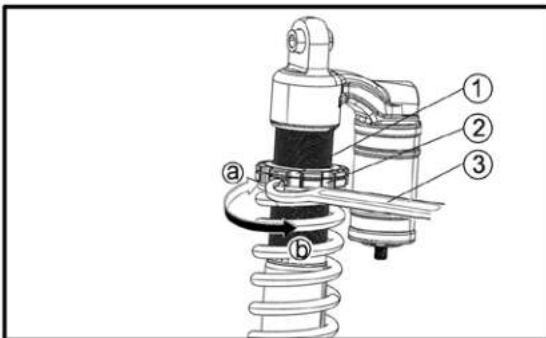

## MAINTENANCE AND ADJUSTMENT OF THE UTV

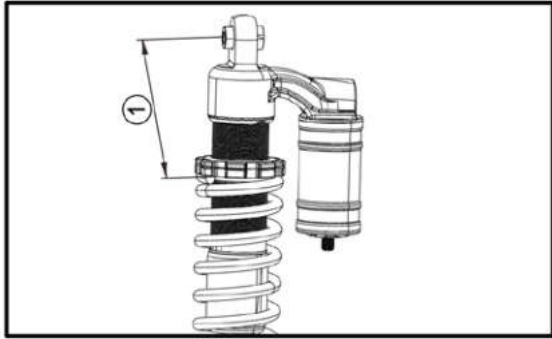

- A special wrench can be obtained at a Bad Boy dealer to make this adjustment.
- The spring preload setting is determined by measuring ①, shown in the illustration. The shorter ① is, the lower the spring preload; the longer distance A is, the higher the spring preload. With each complete turn of the adjusting nut.

### Spring travel setting(Front)

Maximum(hard): 140mm

### Spring travel setting(Rear)

Maximum(hard): 120mm

3. Tighten the locknut.

### NOTE:

Always tighten the locknut against the adjusting nut, and then tighten it to the specified torque.

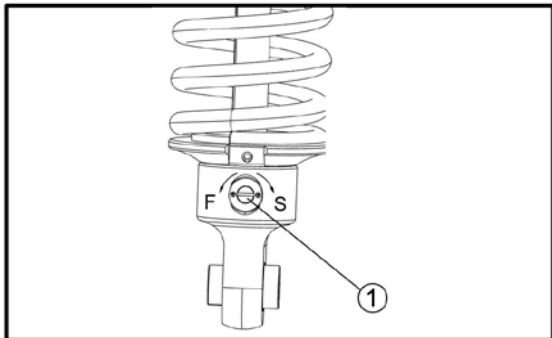

### Rebound damping force

Turn the rebound damping force adjusting screw ① in direction **S** to increase the rebound damping force and thereby harden the damping, and in direction **F** to decrease the rebound damping force and thereby soften the damping.

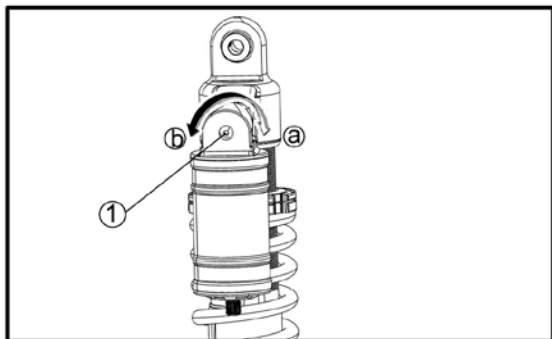

### Compression damping force

Turn the compression damping force adjusting screw ① (use 3.0 allen wrench) in direction **a** to increase the compression damping force and thereby harden the damping, and in direction **b** to decrease the compression damping force and thereby soften the damping.

### WARNING:

• *Suspension components become hot during operation. Never touch the compression damping force adjusting screw, the rebound damping force adjusting screw or the oil reservoir with your bare hand or skin until suspension components have cooled.*

• *Always adjust the shock absorber assemblies on the left and right side to the same*

## MAINTENANCE AND ADJUSTMENT OF THE UTV

---

*setting. Uneven adjustment can cause poor handling and loss of stability, which could lead to an accident.*

---

### CHECKING THE TIRES

#### **WARNING:**

---

#### • **TIRE CHARACTERISTICS**

*Tyre characteristics influence the handling of vehicle's. If other tire combinations are used, they can adversely affect your vehicle's handling characteristics and are therefore not recommended.*

	Size	Type
Front	6PR	26× 9-14
Rear	6PR	26× 11-14

#### • **TIRE PRESSURE**

##### a. Recommended tire cold pressure

*Front 100Kpa (14psi)*

*Rear 100KPa (14psi)*

*when seating the tire beads. Higher pressure may cause the tire to burst.*

*Inflate the tires slowly and carefully.*

*Fast inflation could cause the tire to burst.*

#### • **MAXIMUM LOADING LIMIT**

a. *Vehicle loading limit (total weight of cargo, operator, passenger and accessories, and tongue weight): 399kg*

b. *Cargo bed: 159kg*

c. *Trailer hitch:*

*Pulling load (total weight of trailer and cargo): 544 kg*

*Tongue weight (vertical weight on trailer hitch point): 50 kg*

*Be extra careful of the vehicle balance and stability when towing a trailer.*

1. Measure:

- Tire pressure (cold tire pressure) out of → specification Adjust.

## MAINTENANCE AND ADJUSTMENT OF THE UTV

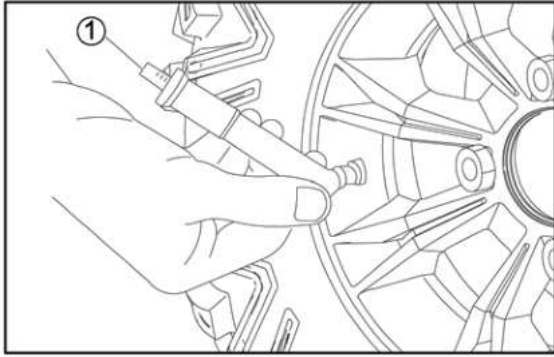

### NOTE:

- The tire pressure gauge ① is in standard equipment.
- If dust or the like is stuck to this gauge, it will not provide the correct readings. Therefore, take two measurements of the tire's pressure and use the second reading.

### WARNING:

*Uneven or improper tire pressure may adversely affect the handling of this vehicle and may cause loss of control.*

- *Maintain proper tire pressures.*
- *Set tire pressures when the tires are cold.*
- *Tire pressures must be equal in both front tires and equal in both rear tires.*

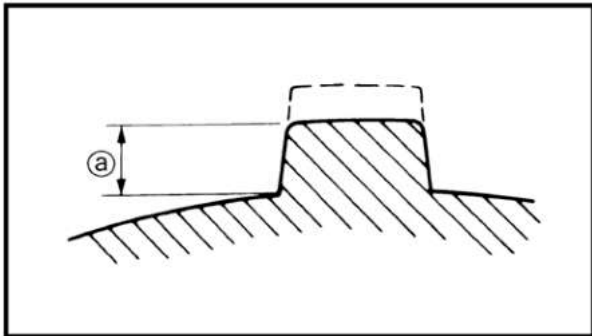

2. Check:

- tire surfaces

Wear/damage@ → Replace.

**Tire wear limit @**

**Front and rear: 3.0 mm (0.12 in)**

### WARNING:

*It is dangerous to ride with a worn-out tire.*

*When tire wear is out of specification, replace the tire immediately.*

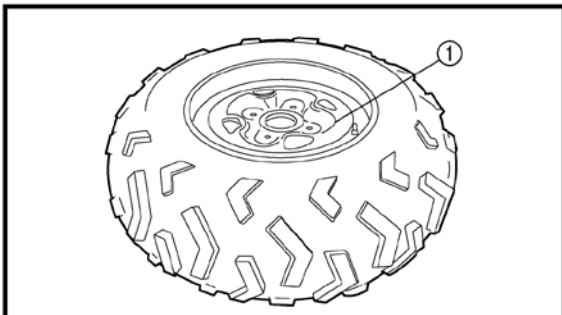

### CHECKING THE WHEELS

1. Check:

- Wheels ↔ Replaced

### NOTE:

*Always balance the wheel when a tire or wheel has been changed or replaced.*

### WARNING:

- *Never attempt even small repairs to the wheel.*
- *Ride conservatively after installing a tire to allow it to seat itself properly on the rim.*

## **MAINTENANCE AND ADJUSTMENT OF THE UTV**

---

### **CHECKING AND LUBRICATING THE CABLES**

**WARNING:**

*A damaged cable sheath may cause corrosion and interfere with the cable movement. An unsafe condition may result so replace a damaged cable as soon as possible.*

---

1. Check:

- cable sheath Damage → Replace.
- cable operation Unsmooth operation → Lubricate or replace.

**NOTE:**

**Hold the cable end up and apply several drops of lubricant to the cable.**

---

2. Apply:

- lithium-soap-based grease (onto end of the cable)

## MAINTENANCE AND ADJUSTMENT OF THE UTV

---

### ELECTRICAL

#### CHECKING AND CHARGING THE BATTERY

**WARNING:**

---

*Batteries generate explosive hydrogen gas and contain electrolyte which is made of poisonous and highly caustic sulfuric acid.*

*Therefore, always follow these preventive measures:*

- *Wear protective eye gear when handling or working near batteries;*
- *Charge batteries in a well-ventilated area;*
- *Keep batteries away from fire, sparks or open flames (e.g., welding equipment, lighted cigarettes);*
- *Do not smoke when charging or handling batteries;*
- *keep batteries and electrolyte out of reach of children;*
- *Avoid bodily contact with electrolyte as it can cause severe burns or permanent eye injury;*

*first aid in case of bodily contact:*

*External*

- *Skin — Wash with water;*
- *Eyes — Flush with water for 15 minutes and get immediate medical attention;*

*Internal*

*Drink large quantities of water or milk followed with milk of magnesia, beaten egg or vegetable oil. Get immediate medical attention.*

---

**WARNING:**

---

- *This is a sealed battery. Never remove the sealing caps because the balance between cells will not be maintained and battery performance will deteriorate;*
- *Charging time, charging amperage and charging voltage for an MF battery are*

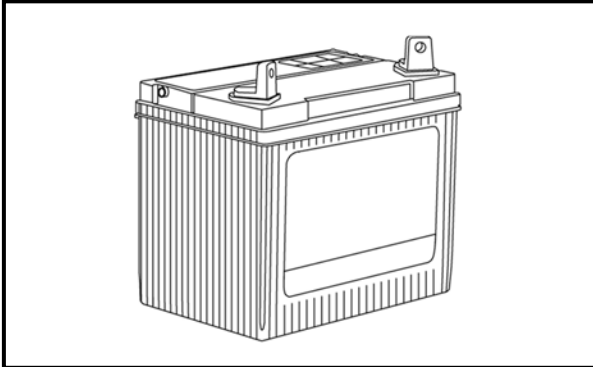

## MAINTENANCE AND ADJUSTMENT OF THE UTV

*different from those of conventional batteries. The MF battery should be charged as explained in the charging method illustrations. If the battery is overcharged, the electrolyte level will drop considerably;*

- *Therefore, take special care when charging the battery.*

### **NOTE:**

Since MF batteries are sealed, it is not possible to check the charge state of the battery by measuring the specific gravity of the electrolyte. Therefore, the charge of the battery has to be checked by measuring the voltage at the battery terminals.

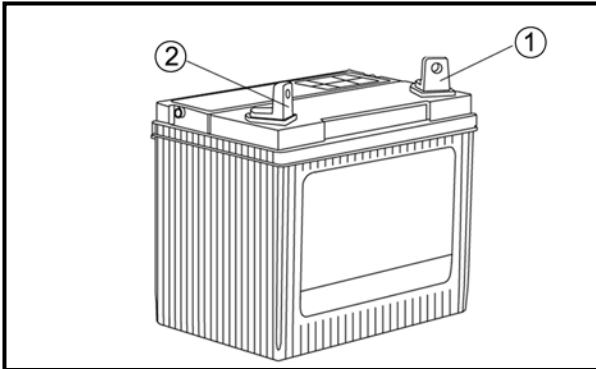

1. Remove:
  - Lift the hood up;
  - battery case cover;
  - disconnect;  
battery leads

### **NOTE:**

First, disconnect the negative battery lead ①, and then the positive battery lead ②.

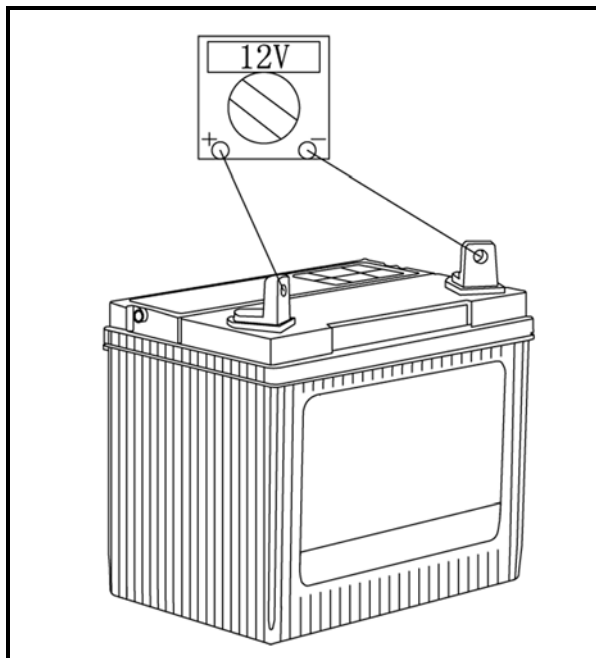

- Remove;  
battery
  - Check;  
battery charge
- a. Connect a pocket tester to the battery terminals.

Positive tester probe →  
positive battery terminal  
Negative tester probe →  
negative battery terminal

### **NOTE:**

- The charge state of an MF battery can be checked by measuring its open-circuit voltage (i.e., the voltage when the positive terminal is disconnected).
- No charging is necessary when the open-circuit voltage equals or exceeds 12.8 V.



## MAINTENANCE AND ADJUSTMENT OF THE UTV

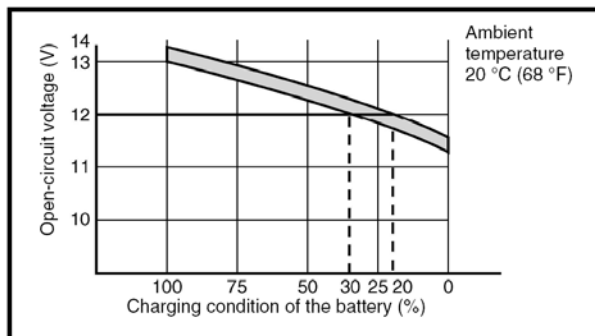
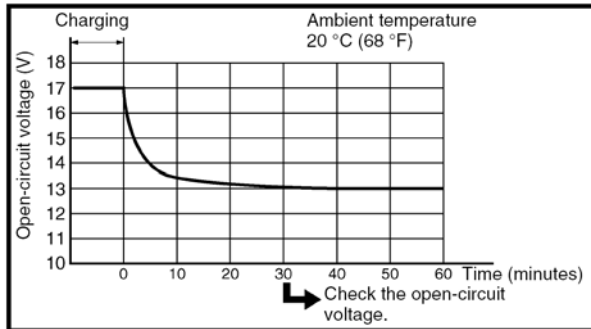
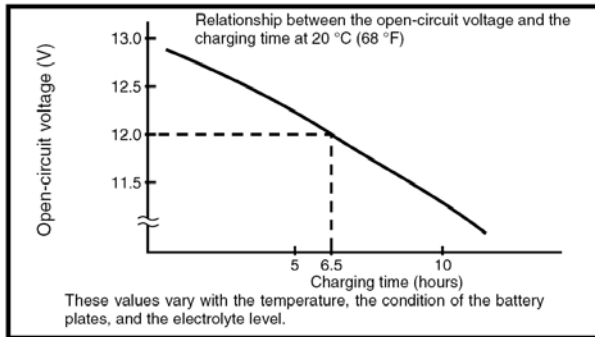

b. Check the charge of the battery, as shown in the charts and the following example.

Example

c. Open-circuit voltage = 12.0 V

d. Charging time = 6.5 hours

e. Charge of the battery = 20 ~ 30%

2. Charge:

- Battery (refer to the appropriate charging method illustration) .

### **WARNING:**

Do not quick charge a battery.

### **NOTE:**

- Never remove the MF battery sealing caps.
- Do not use a high-rate battery charger since it forces a high-amperage current into the battery quickly and can cause battery overheating and battery plate damage.
- If it is impossible to regulate the charging current on the battery charger, be careful not to overcharge the battery.
- When charging a battery, be sure to remove it from the vehicle. (If charging has to be done with the battery mounted on the vehicle, disconnect the negative battery lead from the battery terminal).
- To reduce the chance of sparks, do not plug in the battery charger until the battery charger leads are connected to the battery.
- Before removing the battery charger lead clips from the battery terminals, be sure to turn off the battery charger.
- Make sure the battery charger lead clips are in full contact with the battery terminal and that they are not shorted. A corroded battery charger lead clip may generate heat in the contact area and a weak clip spring may cause sparks.
- If the battery becomes hot to the touch at any time during the charging process, disconnect the battery charger and let the battery cool before reconnecting it. Hot batteries can

## MAINTENANCE AND ADJUSTMENT OF THE UTV

---

explode!

they are not shorted. A corroded battery charger lead clip may generate heat in the contact area and a weak clip spring may cause sparks.

- If the battery becomes hot to the touch at any time during the charging process, disconnect the battery charger and let the battery cool before reconnecting it. Hot batteries can explode!
- As shown in the following illustration, the open-circuit voltage of an MF battery stabilizes about 30 minutes after charging has been completed. Therefore, wait 30 minutes after charging is completed before measuring the open-circuit voltage.

---

Charging method using a variable-current (voltage) charger

**NOTE:**

---

- Leave the battery unused for more than 30 minutes before measuring its open-circuit voltage.
  - Set the charging voltage to 14.0 ~14.2 V. (If the charging voltage is lower, charging will be insufficient, if it is higher, the battery will be over-charged.)
-

## MAINTENANCE AND ADJUSTMENT OF THE UTV

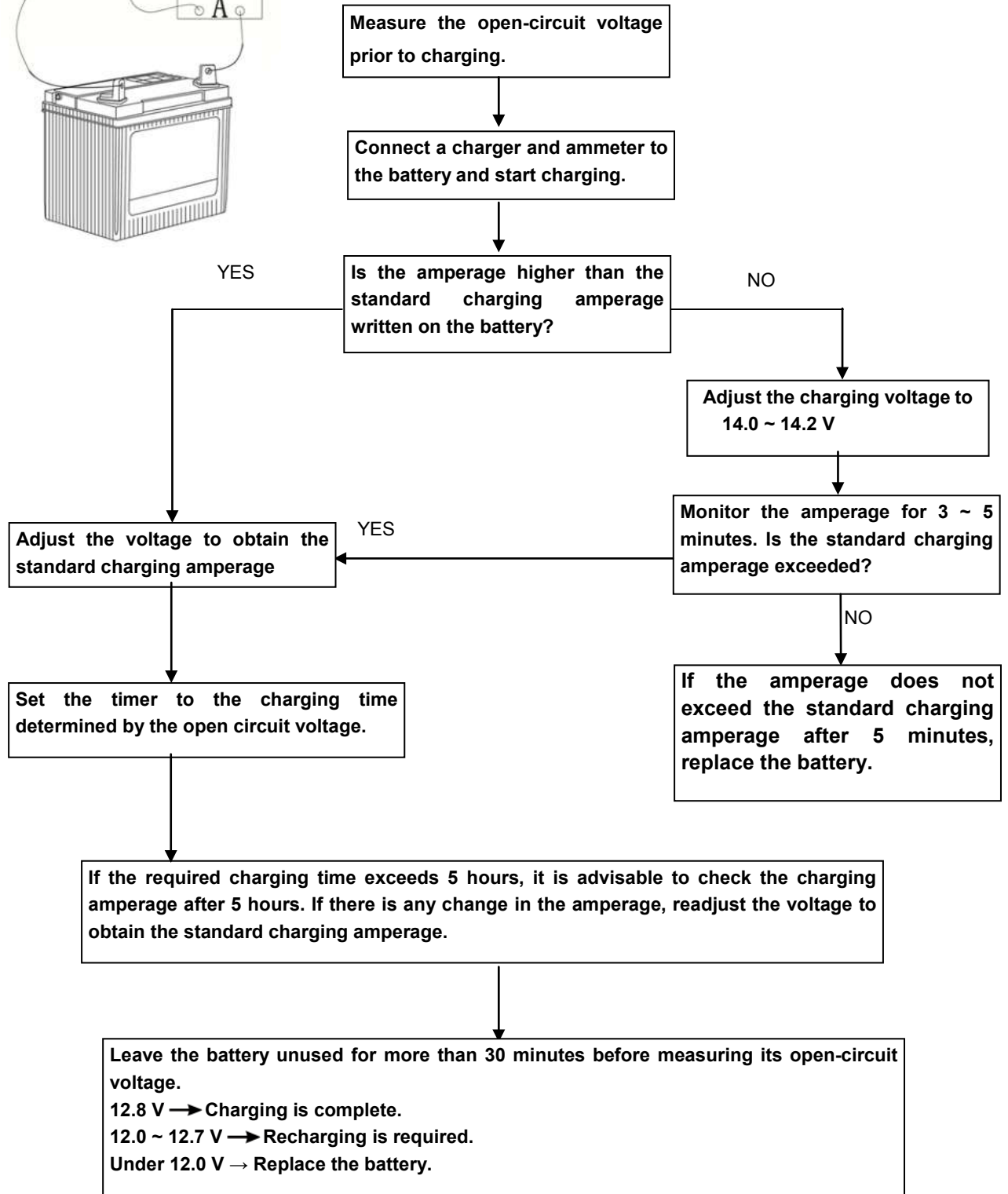
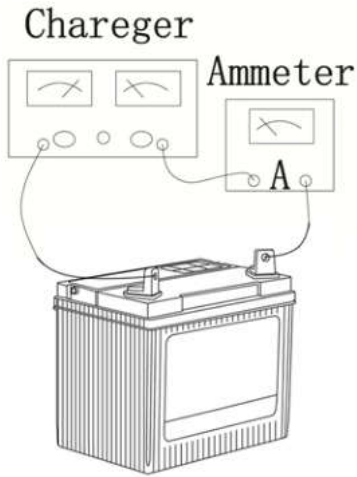

## MAINTENANCE AND ADJUSTMENT OF THE UTV

Charging method using a constant voltage charger

**NOTE:**

Leave the battery unused for more than 30 minutes before measuring its open-circuit voltage.

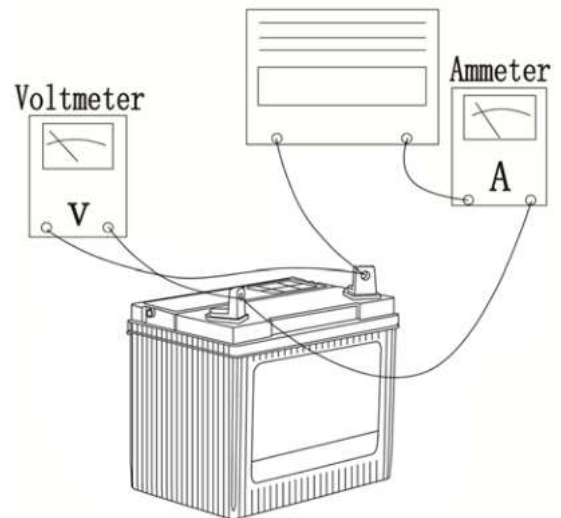
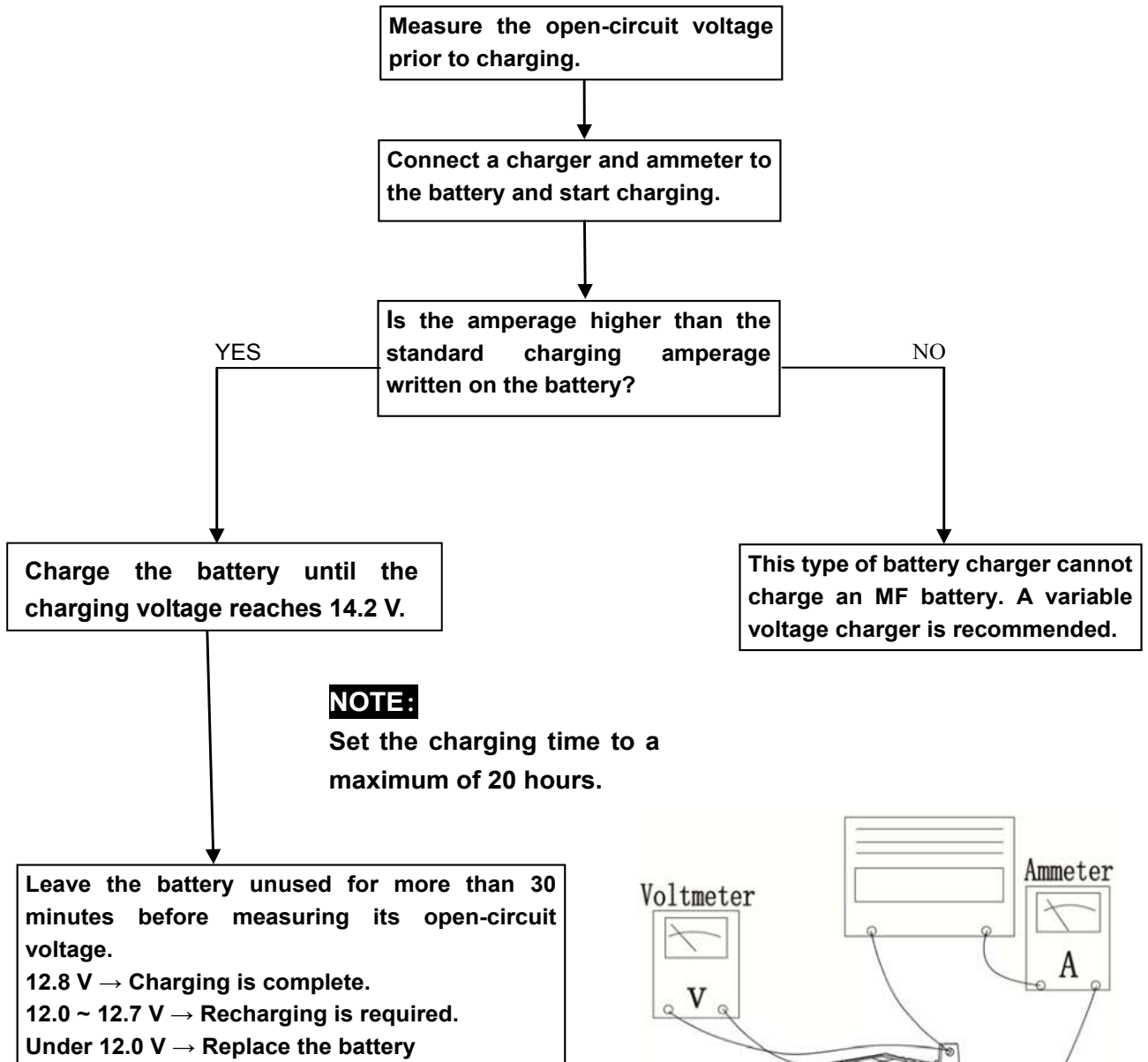

## MAINTENANCE AND ADJUSTMENT OF THE UTV

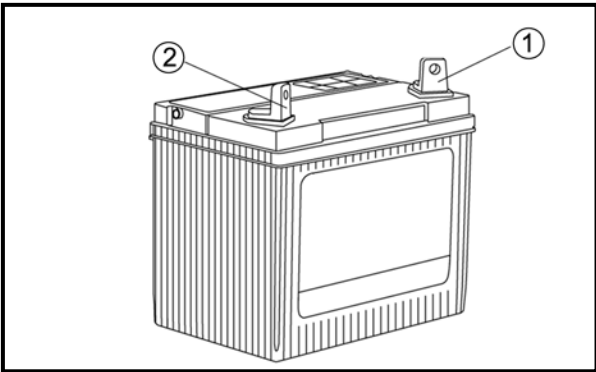

### NOTE:

Constant amperage chargers are not suitable for charging MF batteries.

### 3. Install:

- battery
- Connect:  
battery leads

### NOTE:

First, connect the positive battery lead ①, and then the negative battery lead ②.

### • Check:

battery terminals Dirt → Clean with a wire brush.  
Loose connection → Connect properly.

### • Lubricate:

battery terminals

### • Install:

battery case cover

### • Close the hood.

## CHECKING THE FUSES

### NOTE:

Always turn off the main switch when checking or replacing a fuse. Otherwise, a short circuit may occur.

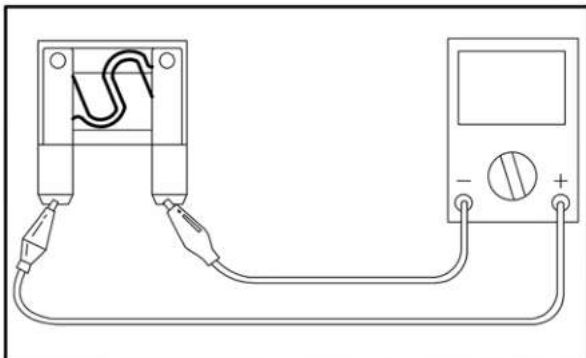
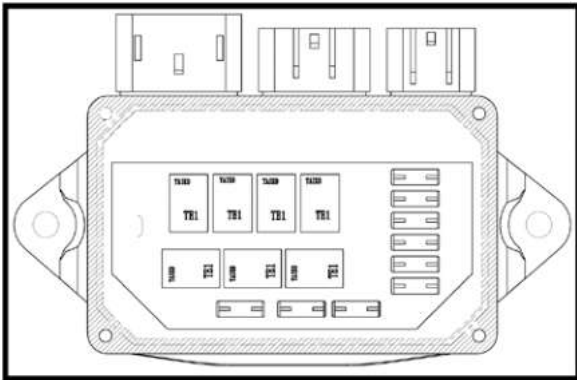

### 1. Remove:

- lift the hood up.
- battery case cover

### 2. Check:

- fuses

a. Connect the pocket tester to the fuse and check it for continuity

### NOTE:

Set the tester to the “ $\Omega \times 1$ ” position.

- blown fuse

## MAINTENANCE AND ADJUSTMENT OF THE UTV

---

- b. If the tester indicates “∞”, replace the fuse.
3. Replace:
  - a. Turn off the ignition.
  - b. Install a new fuse of the proper amperage.
  - c. Turn on switches to verify operation of the related electrical devices.
  - d. If the fuse immediately blows again, check the electrical circuit.

Description	Current rating	Quantity
Lighting system fuse	15 A	1
Ignition	10 A	1
Terminal (Auxiliary DC jack)	10 A	1
4WD(Four wheel drive)	5A	1
Signaling system fuse	10 A	1
Backup fuse	10 A	1
Reserve	15 A	1
Reserve	10 A	1
Reserve	5 A	1

**WARNING:**

*Ever use a fuse with a rating other than that specified. Never use other materials in place of a fuse. An improper fuse may cause extensive damage to the electrical system, a malfunction of the lighting and ignition systems and could possibly cause a fire.*

---

4. Install:
  - battery case cover
5. Close the hood.

## MAINTENANCE AND ADJUSTMENT OF THE UTV

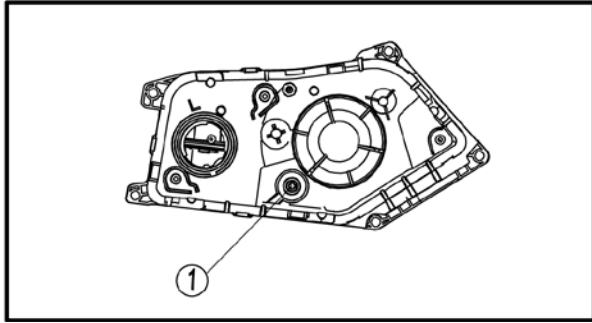

### ADJUSTING THE HEADLIGHT BEAM

1. Adjust:

- headlight beam (vertically)
- turn the adjuster ① in or out

Turning in	Headlight beam raised.
Turning out	Headlight beam lowered.

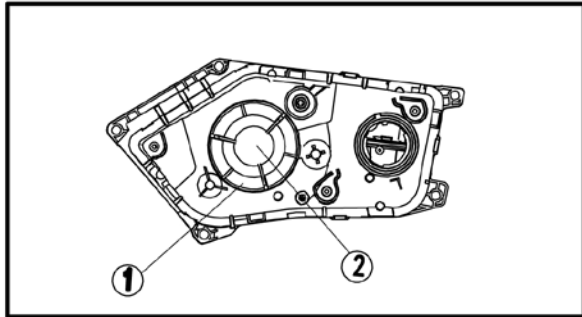

### CHANGING THE HEADLIGHT BULB

Remove:

- Lift the hood up.
- headlight bulb holder cover ①
- headlight bulb holder (with bulb) ②
- bulb

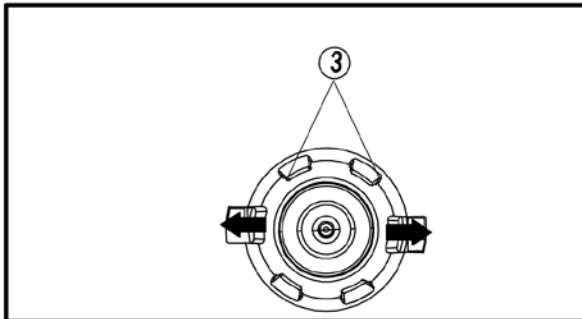

### NOTE:

Remove the defective bulb by unhooking the headlight bulb holder tabs ③

### WARNING:

*Keep flammable products and your hands away from the bulb while it is on, since it will be hot. Do not touch the bulb until it cools down.*

1. Install:

- bulb new

Secure the new bulb with the headlight bulb holder.

### NOTE:

**Avoid touching the glass part of the bulb. Keep it free from oil; otherwise, the transparency of the glass, life of the bulb, and luminous flux will be adversely affected. If oil gets on the bulb, thoroughly clean it with a cloth moistened with alcohol or lacquer thinner.**

- headlight bulb holder (with bulb)
- headlight bulb holder cover
- Close the hood.

## MAINTENANCE AND ADJUSTMENT OF THE UTV

### CHANGING THE TAIL/BRAKE LIGHT BULB

1. Remove:

- Rear panel
- Tail/brake light bulb holder ①
- Secure the new bulb with the rear position lamp direction indicator lamp and stop lamp

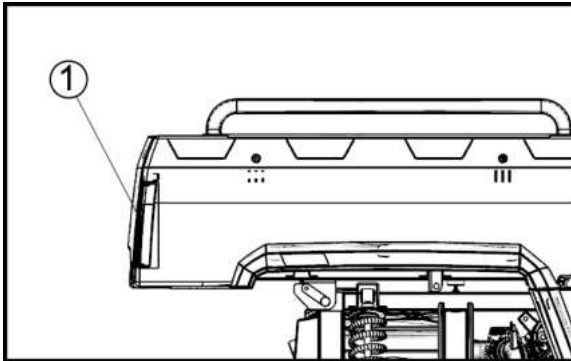

**NOTE:**

Turn the bulb holder counterclockwise and remove the defective bulb.

**WARNING:**

*Keep flammable products and your hands away from the bulb while it is on, since it will be hot. Do not touch the bulb until it cools down.*

2. Install:

- bulb new

Secure the new bulb with the tail/brake light bulb holder.

**NOTE:**

**Avoid touching the glass part of the bulb. Keep it free from oil; otherwise, the transparency of the glass, life of the bulb, and luminous flux will be adversely affected. If oil gets on the bulb, thoroughly clean it with a cloth moistened with alcohol or lacquer thinner.**

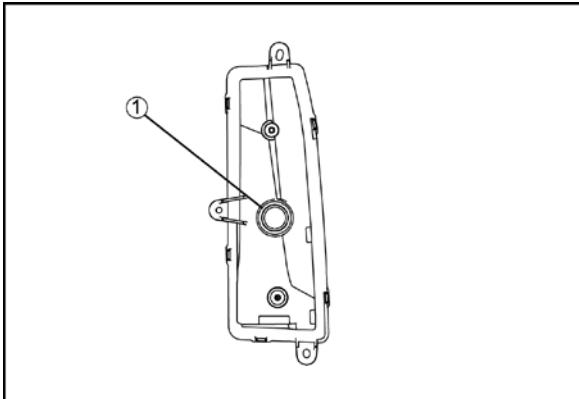

- Tail/brake light bulb holder ①

- bed panel



## ENGINE

---

## ENGINE

### ENGINE NOTE

1. Make sure the components, oil, adhesive, sealant are from the company or recommended.
2. Original removal oil seal, gasket, O-ring, piston ring can not be re-assembled again, make sure all these parts are new.
3. Pay attention to keep dismantled parts orderly, make sure their original positions for reassembling.
4. Prevent dismantled parts damaged, clean before measure and assembly, remove the oil with compressed air. Paint the rotating and sliding parts with specified oil, paint or inject designated location with recommended grease.
5. Bolts and nuts tightening order: pre-fixed bolts, and then tighten them from the large diameter to small diameter, from inside to outside by diagonal points 2 or 3 times to the specified torque. Opposite order is for removing bolts and nuts.
6. Make sure sealing bolt (with the sealant) must be replaced
7. Make sure to use new bearing when remove assembly set up by pressure.
8. Determined axial and radial clearance of inner and outer bearing ring by touch, new bear should be replaced if the clearance is too large or non-rotating flexible.
9. Bearing assembly directions: bearing logo should be visible assemblies; confirm bearing outer ring rotate and move reliably and flexibly when assemble bearing by pressure.
10. Oil seal assembly: pay attention to seal side is in the side of oil, logo side outwards, seal side be painted with grease, and make sure seal side without scratch and oil seal be vertical.
11. Before assembly, sealing material attached to all engine covers and crank case combination surface should be cleaned.
12. Before assembly engine, be familiar with engine lubrication circuit, clean and blow oil circuit.

# ENGINE

## ENGINE REMOVAL

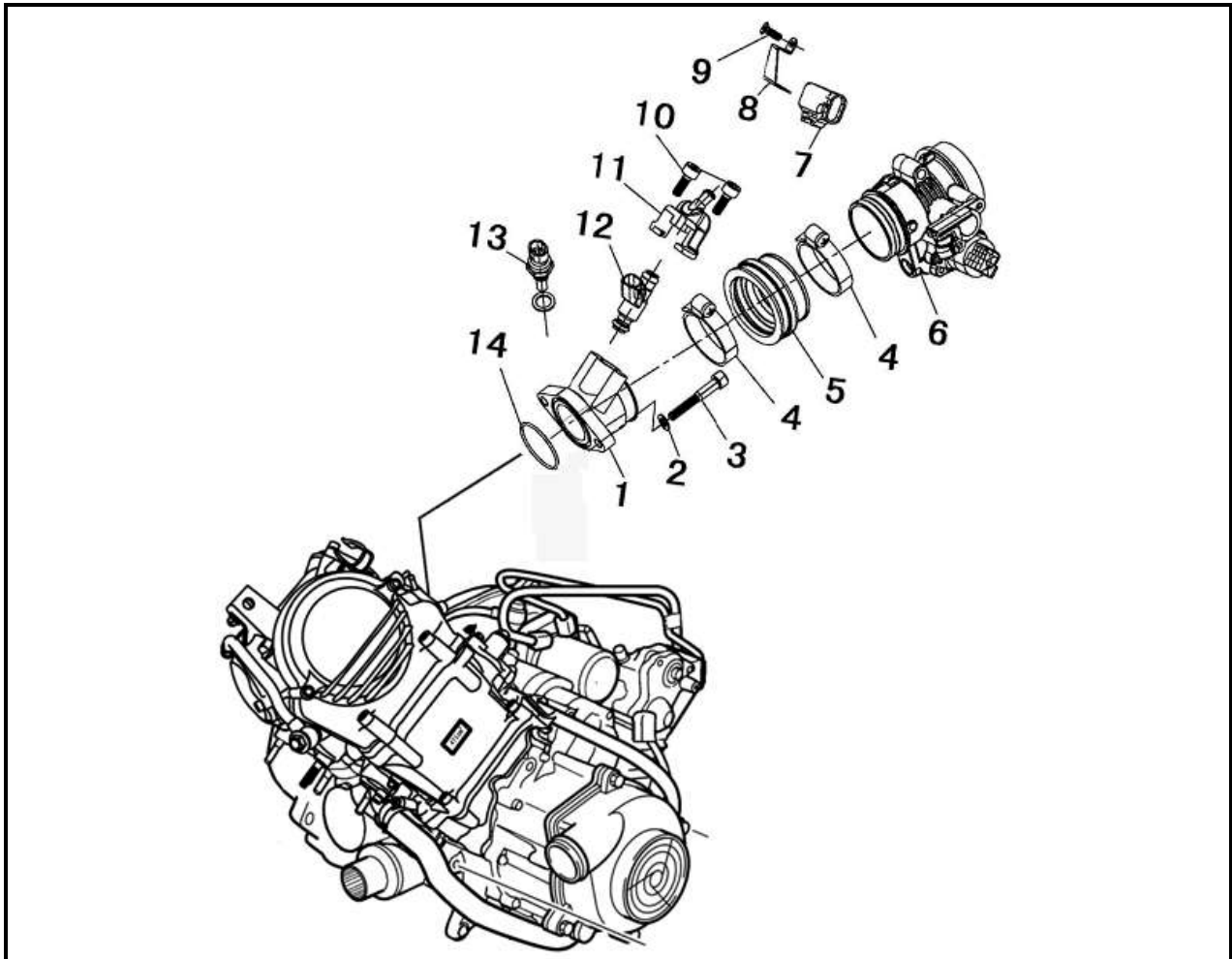

No.	Part Name	Qty	Remarks
	<b>Removing Throttle and intake manifold.</b>		Remove the parts in the order listed.
1	Intake-Tube Assy	1	
2	Washer $\phi 8 \times \phi 16 \times 1.5$	2	
3	Hexagon socket head cap screws M8 $\times$ 50	2	
4	Hoop $\phi 50 \sim \phi 70$	2	
5	Intake-Tube Joint	1	
6	Throttle Body Assy (D46-5)	1	
7	Intake air temperature / pressure sensor 28086011	1	
8	Press Plate,Temp	1	
9	Cross recess head screw M4 $\times$ 8	1	For installation, reverse the removal procedure.

## ENGINE

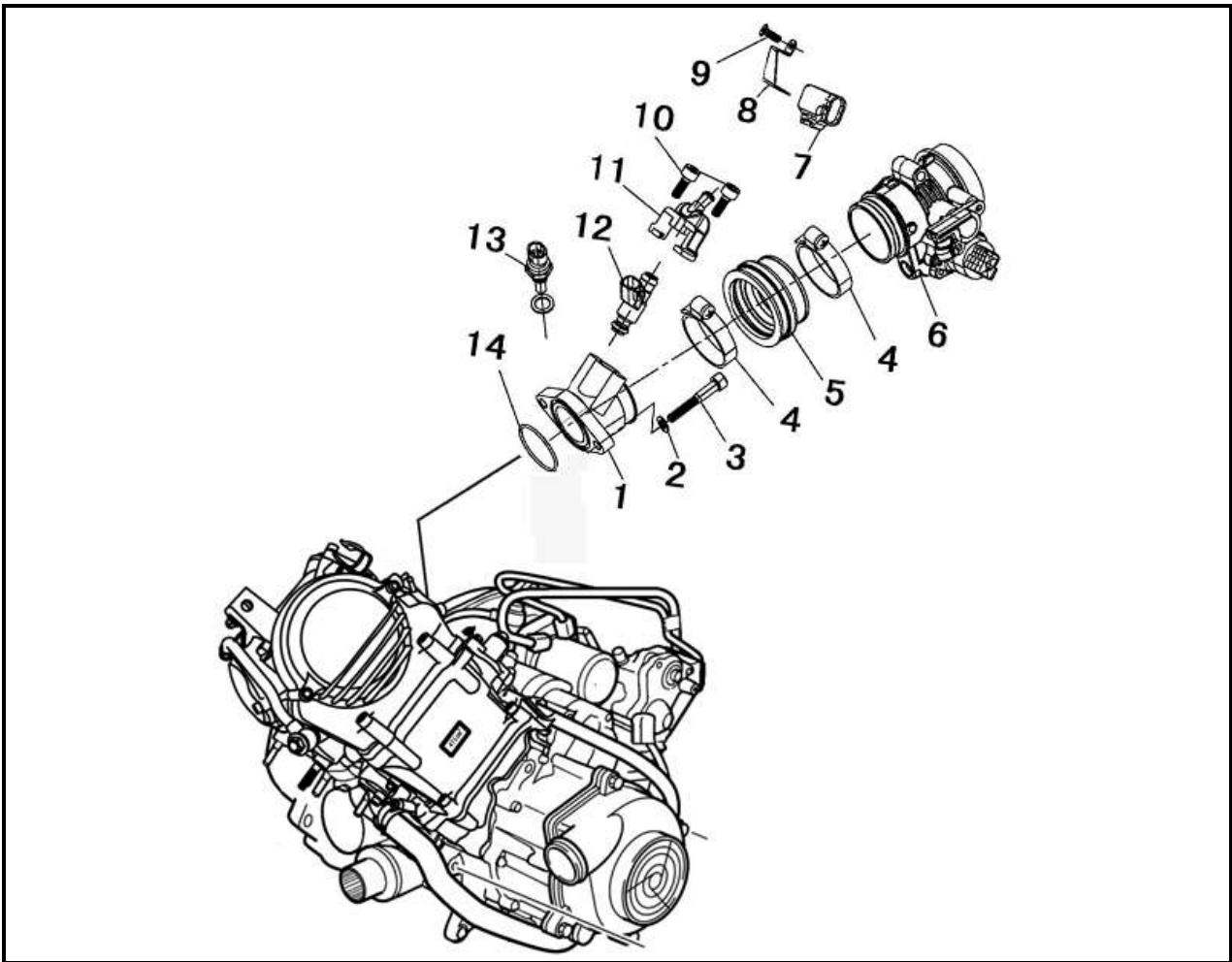

No.	Part Name	Qty	Remarks
	<b>Removing Throttle and intake manifold.</b>		Remove the parts in the order listed.
10	Cylinder Screw M6×20 inner	2	
11	Mounting seat fuel injector	1	
12	Fuel injector 28160355	1	
13	Water temperature sensor	1	
14	O-ring 44×2	1	For installation, reverse the removal procedure.

## ENGINE

---

### 1、 NOTE

- Removing the drain plug

**NOTE:** \_\_\_\_\_

**Before remove drain plug, please prepare vessel for containing oil and cotton yarn.**

---

### 2、 INSTALL

- Install intake manifold
- Install intake manifold bolt
- Install carburetor joint
- Install carburetor

**NOTE:** \_\_\_\_\_

**When installed, don't make an object from the intake fell into the cabinet.**

---

# ENGINE

## CYLINDER HEAD AND CYLINDER HEAD COVER

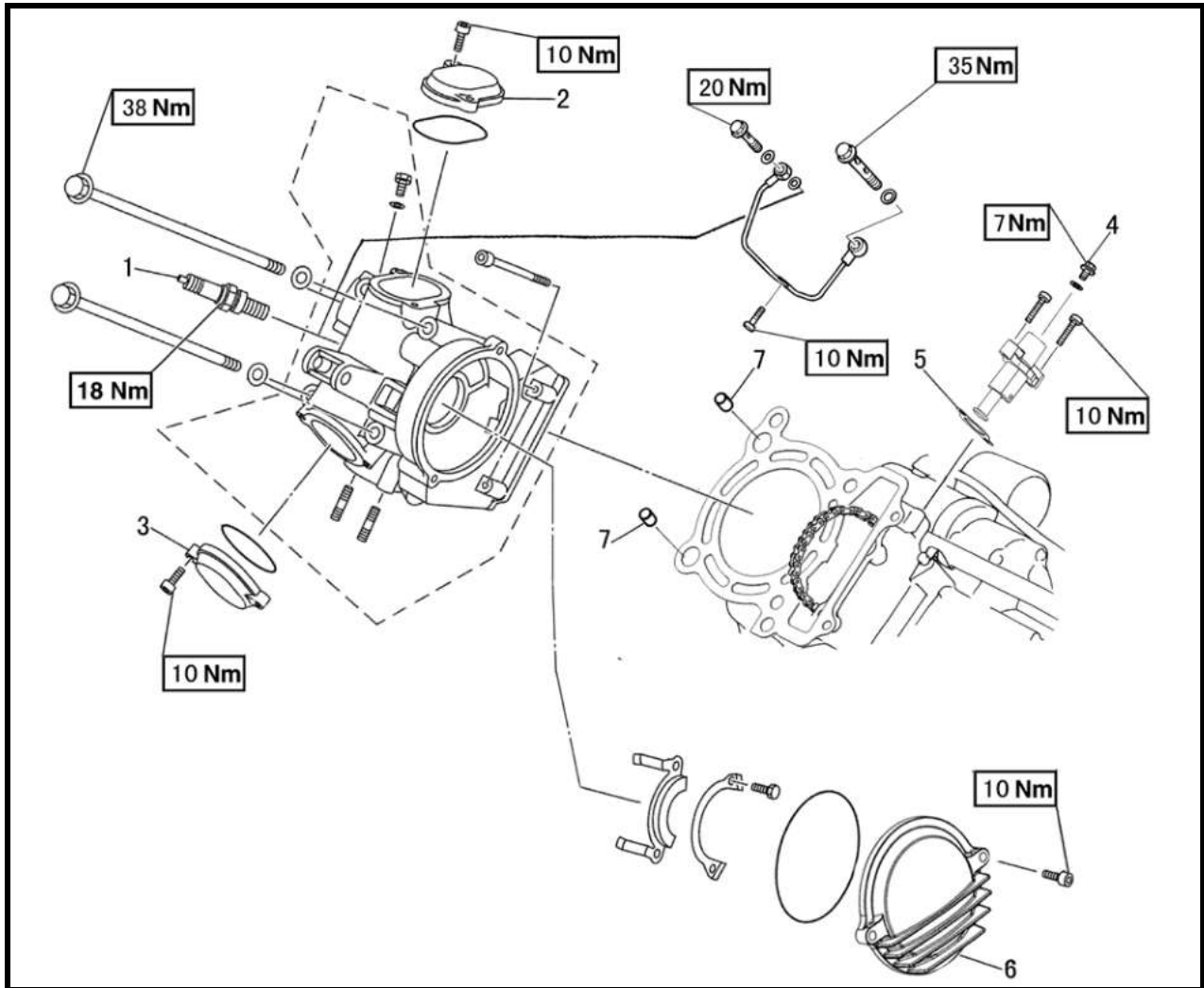

No.	Part Name	Qty	Remarks
	<b>Removing the cylinder head cover and cylinder head</b>		Remove the parts in the order listed.
1	Spark plug	1	
2	Tappet cover (intake)	1	
3	Tappet cover (exhaust)	1	
4	Timing chain tensioner cap bolt	1	
5	Timing chain tensioner / gasket	1/1	
6	Left cover of cylinder head	1	
7	Dowel pin	2	
			For installation, reverse the removal procedure.

# ENGINE

---

## 1. CHECK

### 1). Checking the valve clearance

- Valve clearance

Refer to “ADJUSTING THE VALVE CLEARANCE” in chapter 3.

### 2). Checking the tappet covers

- tappet cover ①

Cracks/damage → Replace.

- O-rings ②

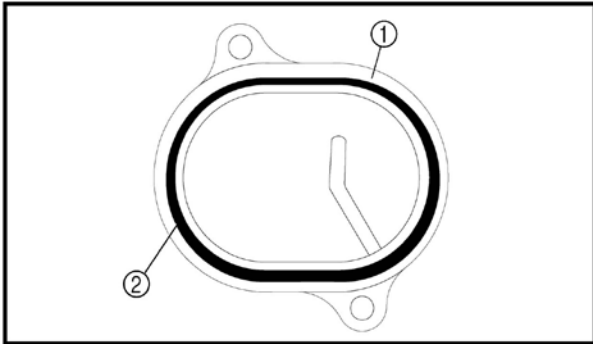

---

**NOTE:**

When installing, new replacement washer and apply wheel bearing grease LS.

---

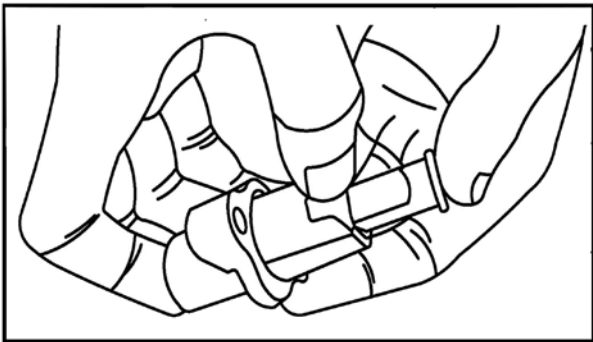

### 3). Removing the timing chain tensioner rod.

---

**NOTE:**

Make sure that the timing chain tensioner rod comes out of the timing chain tensioner housing smoothly. If there is rough movement, replace the timing chain tensioner.

---

### 4). Checking the cylinder head

#### (1). Eliminate:

- carbon deposits (from the combustion chamber)

Use a rounded scraper.

---

**NOTE:**

Do not use a sharp instrument to avoid damaging or scratching:

- spark plug threads
  - valve seats
- 

#### (2). Check:

- cylinder head

Scratches/damage → Replace the cylinder head cover and cylinder head as a set.

- cylinder head water jacket

## ENGINE

---

Mineral deposits/rust → Eliminate.

### 2、INSTALL

#### 1). Installing the cylinder head

- cylinder head
- washers
- bolts

#### **NOTE:**

---

- **Tighten the bolts in the proper sequence.**
- 

- timing chain guide (exhaust side)
  - timing chain tensioner
- a. Lightly press the timing chain tensioner rod into the timing chain tensioner housing by hand.
  - b. While pressing the timing chain tensioner rod, wind it clockwise with a thin screwdriver until it stops.
  - c. With the screwdriver still inserted into the timing chain tensioner, install the timing chain tensioner and gasket onto the cylinder block. Then, tighten the timing chain tensioner bolts to the specified torque.

#### **WARNING:**

---

*Always use a new gasket.*

---

#### **NOTE:**

---

The “UP” mark on the timing chain tensioner should face up.

---

**Timing chain tensioner bolt (10 Nm)**

- d. Remove the screwdriver, make sure that the timing chain tensioner rod releases, and tighten the cap bolt to the specified torque.

**Timing chain tensioner cap bolt (7 Nm)**

# ENGINE

## ROCKER ARMS AND CAMSHAFT

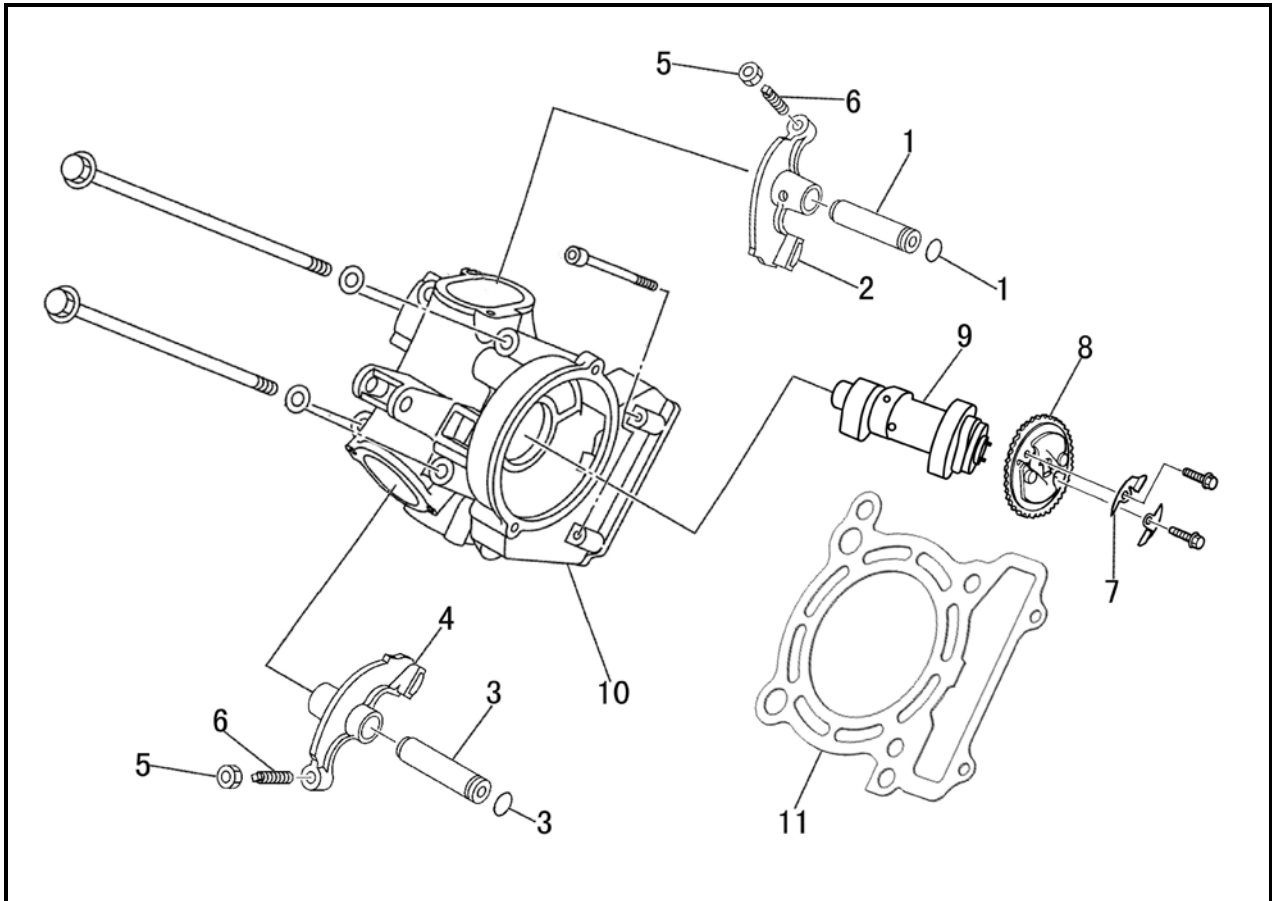

No.	Part Name	Qty	Remarks
	<b>Removing the rocker arms and camshaft</b>		Remove the parts in the order listed.  For installation, reverse the removal procedure.
	Cylinder head cover		
1	Rocker arm shaft 1/O-ring	1/1	
2	Rocker arm 1	1	
3	Rocker arm shaft 2/O-ring	1/1	
4	Rocker arm 2	1	
5	Locknut	2	
6	Valve adjuster	2	
7	Decompress or cam guide plate	2	
8	Camshaft sprocket	1	
9	Camshaft	1	
10	Cylinder head	1	
11	Cylinder head gasket	1	



## ENGINE

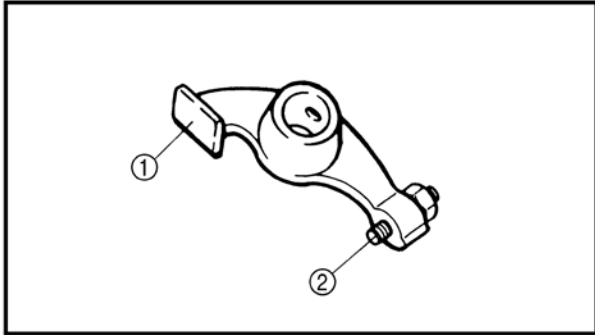

### 1、CHECK

#### 1). Checking the rocker arms

- rocker arm lobes ①
- valve adjusters ②

Blue discoloration / pitting / scratches → Replace.

- rocker arms
- rocker arm shafts

Damage/wear → Replace.

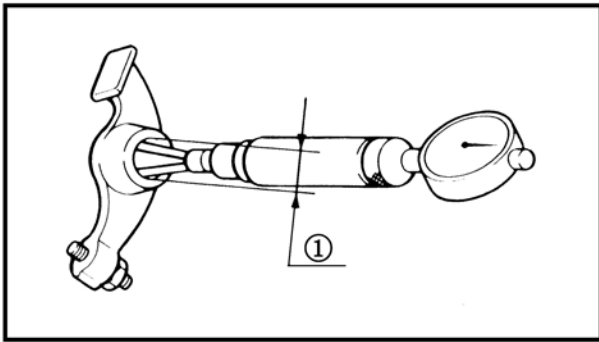

- a. Check whether the rocker arm is worn out, or damaged and whether the oil hole is blocked.
- b. If there is a rocker arm to be replaced, check the camshaft prominent position of unfairness.
- c. Measure the inside diameter of the rocker arm holes ①.

Out of specification → Replace.

**Rocker arm inside diameter repairing limit value**

**Φ12.038mm**

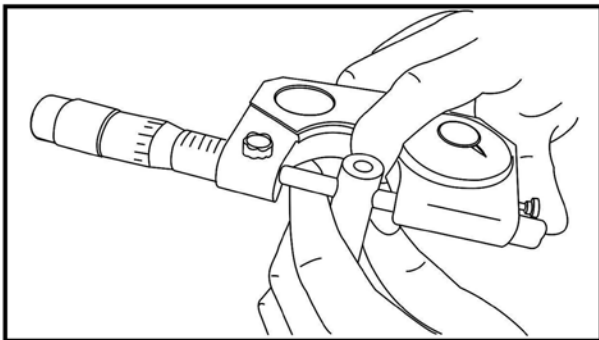

- d. Check the surface of the rocker arm shafts.  
Worn/pitting/scratches → Replace.
- e. Measure the external diameter of rocker arm shaft with micrometer.

Out of specification → Replace.

**Rocker arm shaft outside diameter repairing limit value**

**Φ11.96mm**

- f. Calculate the clearance by subtracting the rocker arm shaft outside diameter from the rocker arm inside diameter.

Out of specification → Replace the defective part(s).

**Rocker arm to shaft clearance repairing limit value**

**0.05mm**

## ENGINE

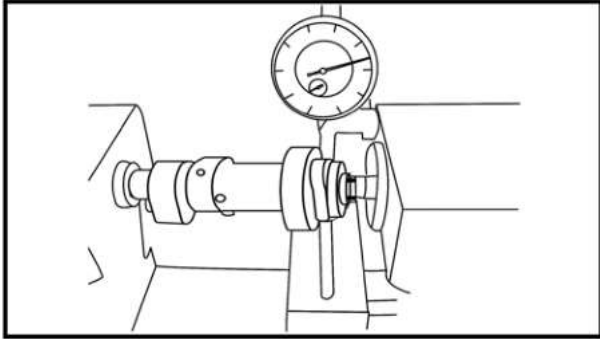

### 2). Checking the camshaft

- cam lobes  
Pitting/scratches/blue discoloration → Replace
- camshaft journal  
Wear/damage → Replace
- Measure the external diameter of camshaft journal with micrometer.  
Out of specification → Replace.
- small holes on camshaft sprocket
- rotor “I” mark  
Out of alignment

### 3). Checking the camshaft sprocket

- camshaft sprocket  
Wear/damage → Replace the camshaft sprocket and timing chain as a set.

(a) 1/4 of a tooth

(b) Correct

① Timing chain

② Sprocket

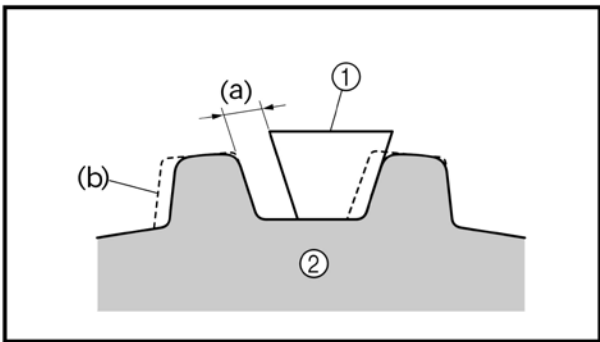

### 4). Checking the decompression system

- decompression system  
Check while the camshaft sprocket is installed on the camshaft.
- a. Check that the decompressor cam ① moves smoothly.
- b. Check that the decompressor lever pin ② projects from the camshaft.

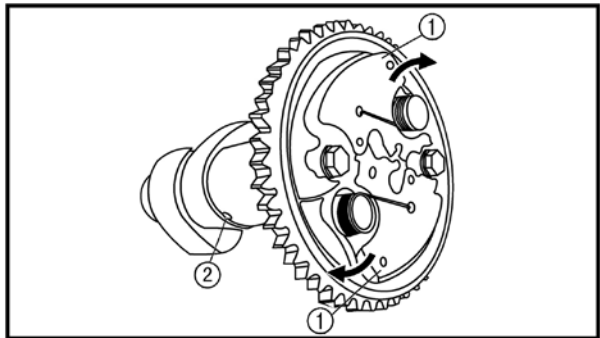

## 2. INSTALL

### 1). Installing the rocker arms

- rocker arms ①
- rocker arm shafts ②

#### **NOTE:**

- The thread hole (a) of the rocker arm shaft must face to the outside.
- After installation, make sure that the thread hole (a) of the rocker arm shaft is positioned correctly, as shown in the illustration.

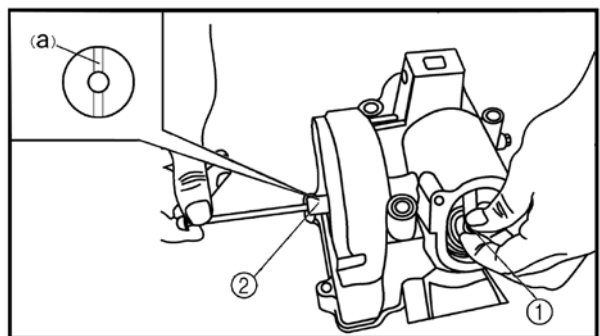

## ENGINE

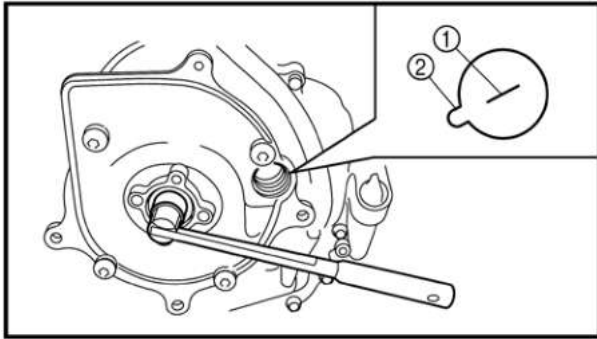

### 2). Installing the camshaft

- camshaft
- camshaft sprocket

- Turn the crankshaft counterclockwise with a T-sleeve.
- Align the "I" mark ① on the rotor with the stationary pointer ② on the A.C. magneto cover. When the "I" mark is aligned with the stationary pointer, the piston is at the Top Dead Center (TDC).

#### **CAUTION:**

**Do not turn the crankshaft during the camshaft installation.**

- Align the notches ③ on the decompressor cams with the projections ④ on the decompressor spring lever, then install the camshaft sprocket on the camshaft.

#### **NOTE:**

**Check that each part is positioned as shown in the illustration.**

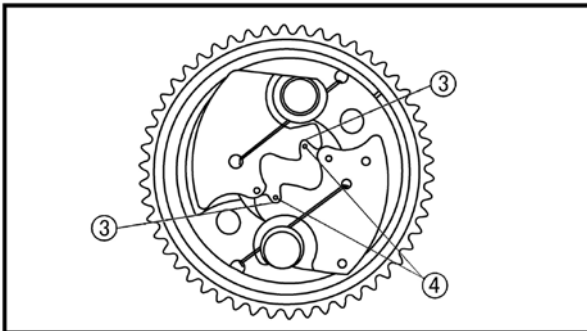

- Install the decompressor cam guide plates ⑤ and camshaft sprocket bolts ⑥

**Camshaft sprocket bolt(20 Nm)**

#### **NOTE:**

**Insert a screwdriver into the timing chain tensioner hole and push the timing chain guide (intake side) inward.**

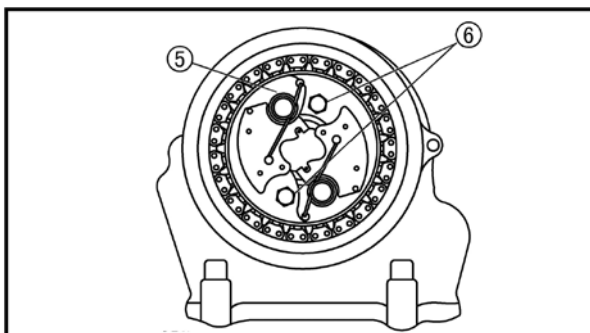

- Remove the retaining wire.

# ENGINE

## VALVES AND VALVE SPRINGS

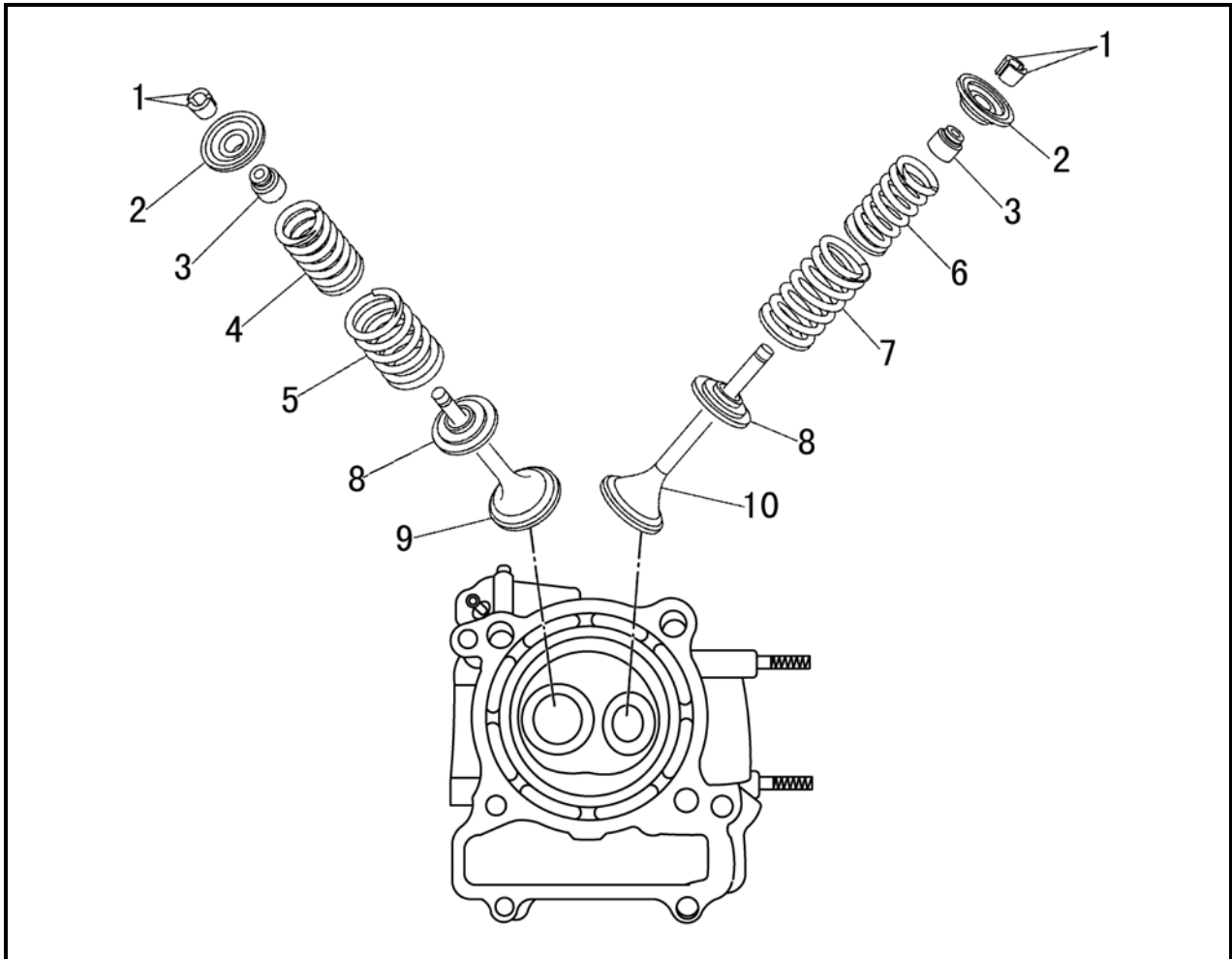

No.	Part Name	Qty	Remarks
	<b>moving the valves and valve springs</b>		Remove the parts in the order listed.
	Cylinder head cover		
1	Valve cotter	2	
2	Valve spring retainer	2	
3	Valve stem seal	2	
4	Intake valve with inner spring	1	
5	Intake valve with outer spring	1	
6	Exhaust valve with inner spring	1	
7	Exhaust valve with outer spring	1	
8	Valve spring seat	2	
9	Intake valve	1	
10	Exhaust valve	1	
			For installation, reverse the removal procedure.

# ENGINE

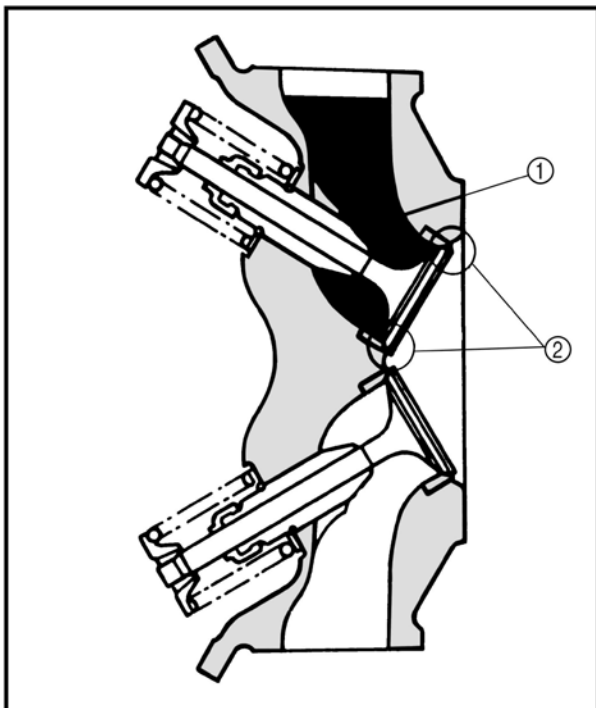

## 1、 CHECK

- valve sealing

Leakage at the valve seat → Check the valve face, valve seat and valve seat width.

- Pour a clean solvent ① into the intake and exhaust ports.
- Check that the valve seals properly. There should be no leakage at the valve seat ②.

- valve face

Pitting/wear → Grind the face.

- valve stem end

Mushroom shape or diameter larger than the body of the stem → Replace.

- valve seats

Pitting/wear → Reface the valve seat.

## 2、 MEASURE:

- Measure:

- The valves surface width

**Repairing limit value**

**2.0mm**

- stem-to-guide clearance

**Stem-to-guide clearance = valve guide inside diameter – valve stem diameter**

### **NOTE:**

If the mating surface is coarse, corrode or cannot contact with valve seat normally, replace it.

**Stem-to-guide clearance repairing limit value**

**Intake: 0.12mm    Exhaust: 0.14mm**

- margin thickness (a)

Out of specification → Replace.

**Margin thickness**

**Intake: 0.85 ~ 1.15 mm**

**Exhaust: 0.85 ~ 1.15 mm**

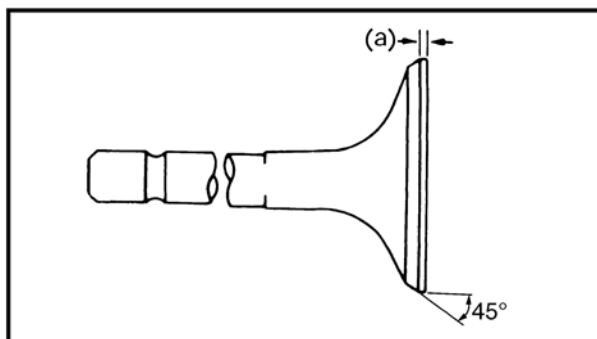

# ENGINE

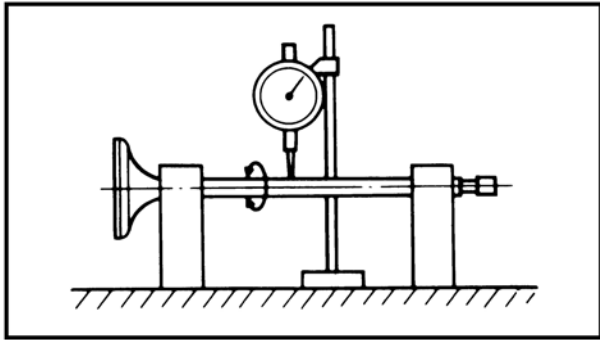

- valve stem runout  
Out of specification → Replace.

**Runout limit 0.01 mm**

**NOTE:**

- When installing a new valve always replace the guide.
- If the valve is removed or replaced always replace the oil seal.

- The valve seat surface width  
Out of specification → Reface the valve seat.

**Repairing limit value  
2.0mm**

- Install the valve into the cylinder head.
- Press the valve through the valve guide and onto the valve seat to make a clear pattern.
- Measure the valve seat width. Where the valve seat and valve face made contact, blueing will have been removed.

- Valve spring free length  
Out of specification → Replace.

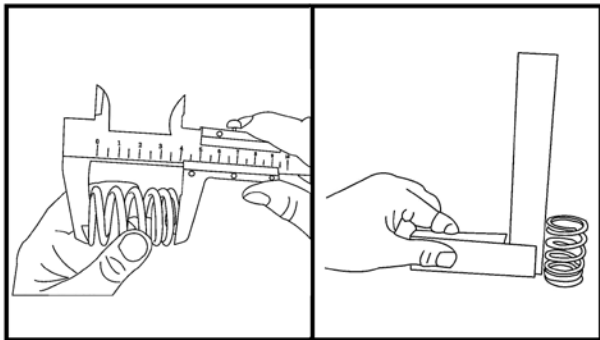

**Valve spring free length**

**Outside spring:**

Intake:42.5mm Exhaust:42.5mm

**Within spring:**

Intake:39.0mm Exhaust:39.0mm

**Valve spring squareness**

Intake:0.10mm Exhaust:0.10mm

- compressed spring force(a)  
Out of specification → Replace.
- (b) Installed length

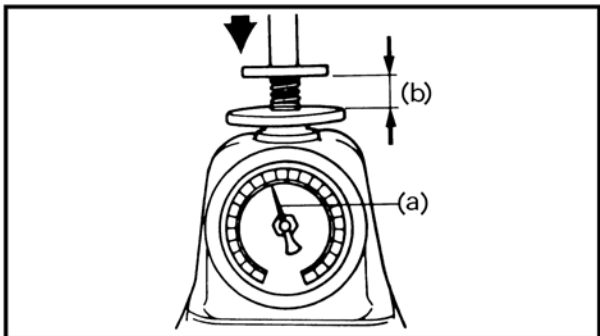

**Compressed spring force**

**Outside spring:**

Intake: 735.0~ 765.0N at 26 mm

Exhaust: 240.0~260.0 N at 36 mm

**Within spring:**

Intake: 100.0 ~ 115.7 N at 27.5 mm

Exhaust: 120.6 ~ 138.3 N at 31.0 mm

## ENGINE

---

- 2). Remove:
- valve guide

**NOTE:**

To ease guide removal, installation and to maintain correct fit, heat the cylinder head to 100 °C (212 °F) in an oven.

---

- 3). Lap:
- valve face
  - valve seat

**NOTE:**

After reface the valve seat or replacing the valve and valve guide, the valve seat and valve face should be lapped.

---

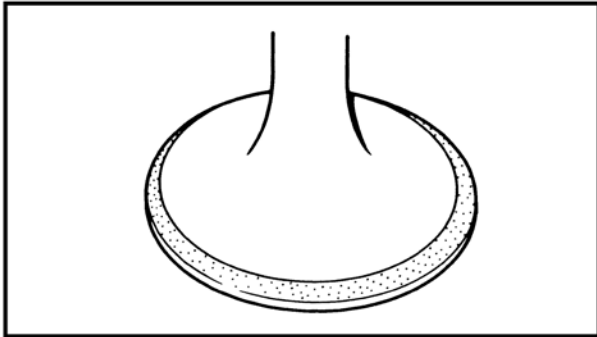

- a. If the pipe will be replaced, grind the valve seat again.

**CAUTION:**

Do not let the compound enter the gap between the valve stem and the guide.

---

- b. Install the valve into the cylinder head.

**NOTE:**

For best lapping results, lightly tap the valve seat while rotating the valve back and forth between your hands.

---

- d. Apply a fine lapping compound to the valve face and repeat the above steps.

**NOTE:**

After every lapping operation be sure to clean off all of the compound from the valve face and valve seat.

---

## ENGINE

---

- e. Install the valve into the cylinder head.
- g. Press the valve through the valve guide and onto the valve seat to make a clear pattern.
- h. Measure the valve seat width again. If the valve seat width is out of specification, reface and relapse the valve seat.

### 3、INSTALL:

#### 1). Apply:

- molybdenum disulfide oil  
(onto the valve stem and valve stem seal)

#### 2). Install:

- valve spring seats
- valve stem seals
- valves
- valve springs
- valve spring retainers

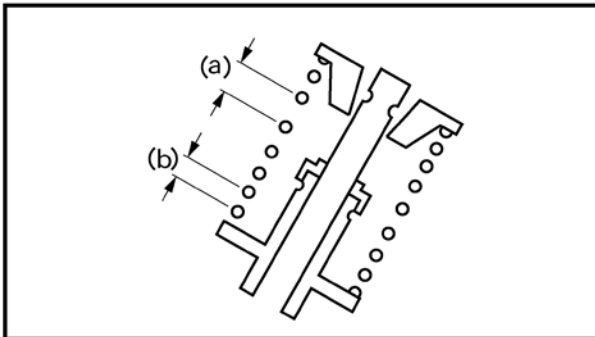

---

**NOTE:**

Install the valve springs with the larger pitch (a) facing upwards.

---

#### (b) Smaller pitch

- valve cotters

---

**NOTE:**

Install the valve cotters while compressing the valve spring with the valve spring compressor ① and valve spring compressor attachment ②.

---

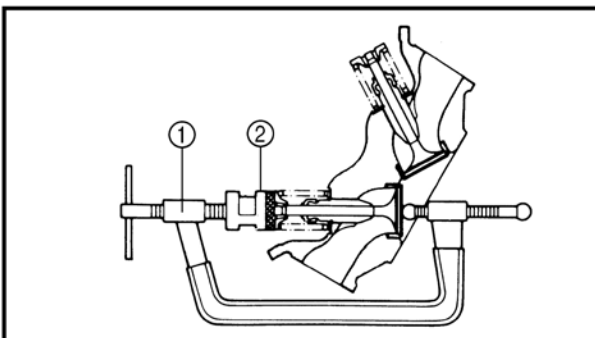

---

**CAUTION:**

Hitting the valve tip with excessive force could damage the valve.

---



# ENGINE

## CYLINDER AND PISTON

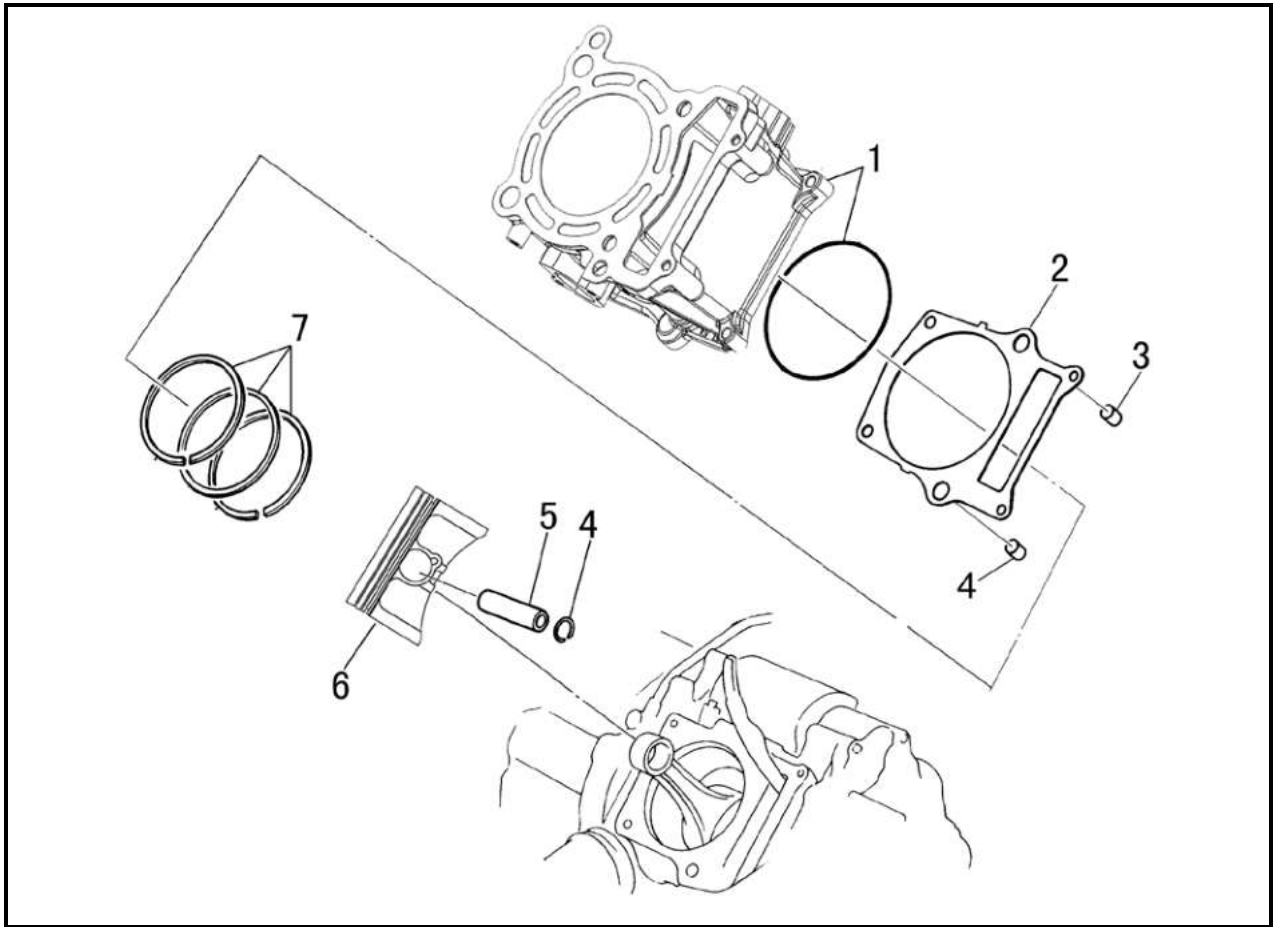

No.	Part Name	Qty	Remarks
	<b>Removing the cylinder and piston</b>		Remove the parts in the order listed.
	Water pump outlet hose		
	Cylinder head		
1	Coolant inlet joint	1	
2	Cylinder/O-ring	1/1	
3	Cylinder gasket	1	
4	Dowel pin	2	
5	Piston pin clip	2	
6	Piston pin	1	
7	Piston	1	For installation, reverse the removal procedure.
8	Piston ring set	1	

# ENGINE

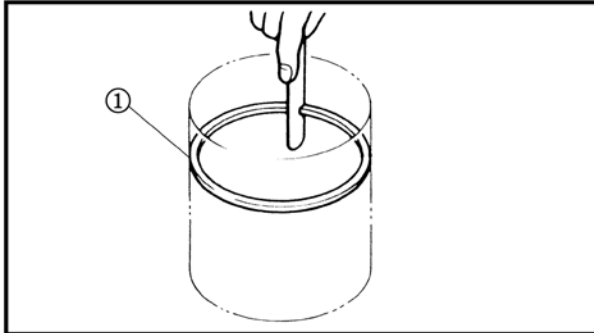

## 1、 CHECK

- 1).Checking the cylinder and piston
  - cylinder and piston walls Vertical scratches → Rebore or replace the cylinder and the piston.
- 2).Checking the piston rings
  - piston ring  
(Insert in cylinder piston ring will be ① ,and measure the end gap.)

### **NOTE:**

**Check whether the piston and the piston groove is cracked and abraded.**

- 3).Checking the piston pin
  - piston pin

Blue discoloration/grooves → Replace, then check the lubrication system.

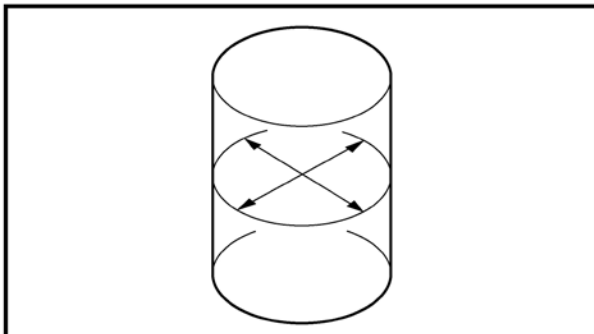

## 2、 MEASURE

- At the top, the middle and the bottom of the piston stroke.

### **NOTE:**

**Measure the bore diameter at directions of right-angle intersection.**

Repairing limit value

Out of roundness:0.005mm

Taper:0.005mm

- The external diameter 10mm above the bottom of the piston skirt.

### **NOTE:**

**Repair limit on the clearance between the piston and cylinder.**

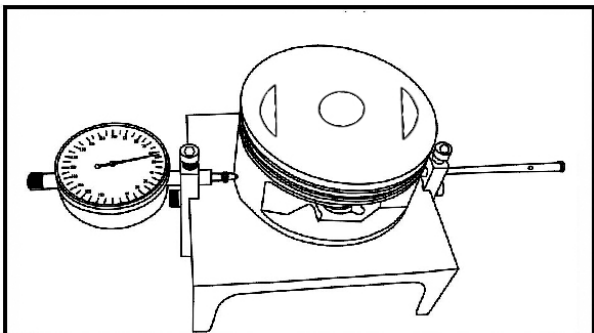

Repairing limit value

0.1mm

## ENGINE

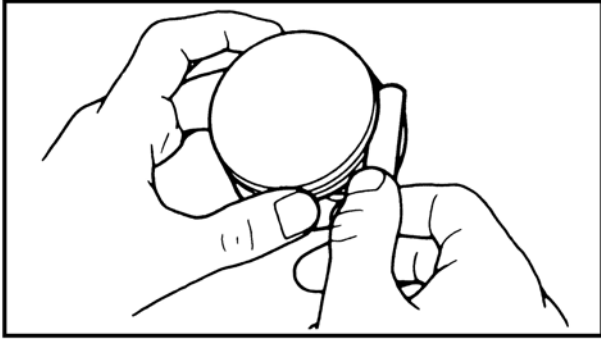

- ring end gap  
Out of specification → Replace.

**Repairing limit value**  
**Top ring/2nd ring:0.5mm**

- ring side clearance  
Use a thickness gauge.  
Out of specification → Replace the piston and rings as a set.

**NOTE:**

**Clean carbon from the piston ring grooves and rings before measuring the side clearance.**

	Side clearance	
	Standard	Limit
<b>Top ring</b>	<b>0.04~0.08mm</b>	<b>0.13mm</b>
<b>2nd ring</b>	<b>0.03~0.07mm</b>	<b>0.13mm</b>

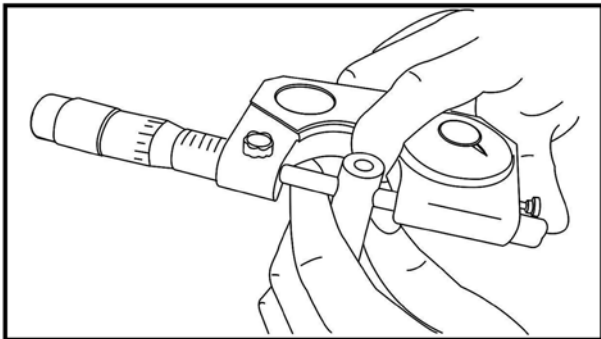

- piston pin-to-piston clearance.
- Measure the piston pin outside diameter.

**Repairing limit value**  
**0.02mm**

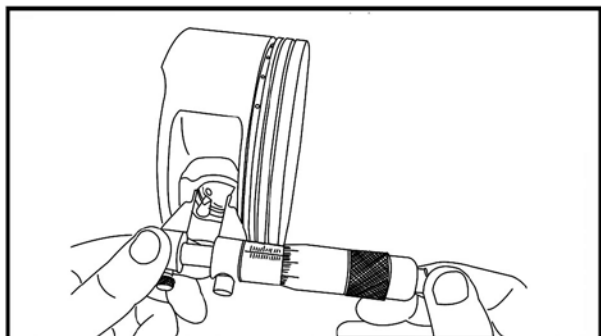

- Measure the piston pin bore inside diameter.

**Repairing limit value**  
**0.02mm**

- Calculate the piston pin-to-piston clearance with the following formula.  
Piston pin-to-piston clearance = Piston pin bore inside diameter – Piston pin outside diameter
- If out of specification, replace the piston.

## ENGINE

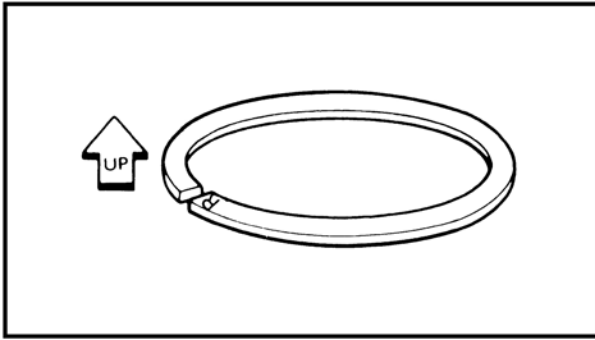

### 3. INSTALL:

#### 1). Installing the piston

- piston rings  
(onto the piston)

#### **NOTE:**

- Be sure to install the piston rings so that the manufacturer's marks or numbers are located on the upper side of the rings.
- Lubricate the piston and piston rings liberally with engine oil.

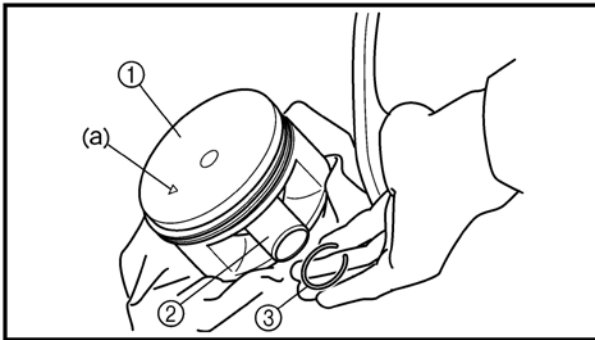

- piston ①
- piston pin ②
- piston pin clips (new replacement)

#### **NOTE:**

- Apply engine oil onto the piston pin, piston rings and piston.
- Be sure that the arrow mark a on the piston points to the exhaust side of the engine.
- Before installing the piston pin clip, cover the crankcase with a clean rag to prevent the piston pin clip from falling into the crankcase.

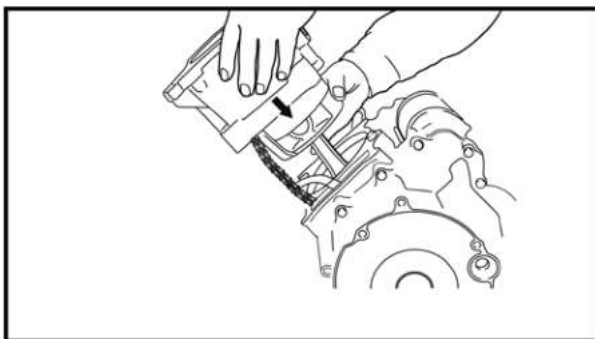

#### 2). Installing the cylinder

- cylinder
- O-ring
- bolts (M10,42Nm)
- bolts (M6,10Nm)

#### **NOTE:**

Install the cylinder with one hand while compressing the piston rings with the other hand.

#### **CAUTION:**

- Be careful not to damage the timing chain guide during installation.
- Pass the timing chain through the timing chain cavity.

# ENGINE

## ENGINE COOLING FAN AND A.C. MAGNETO

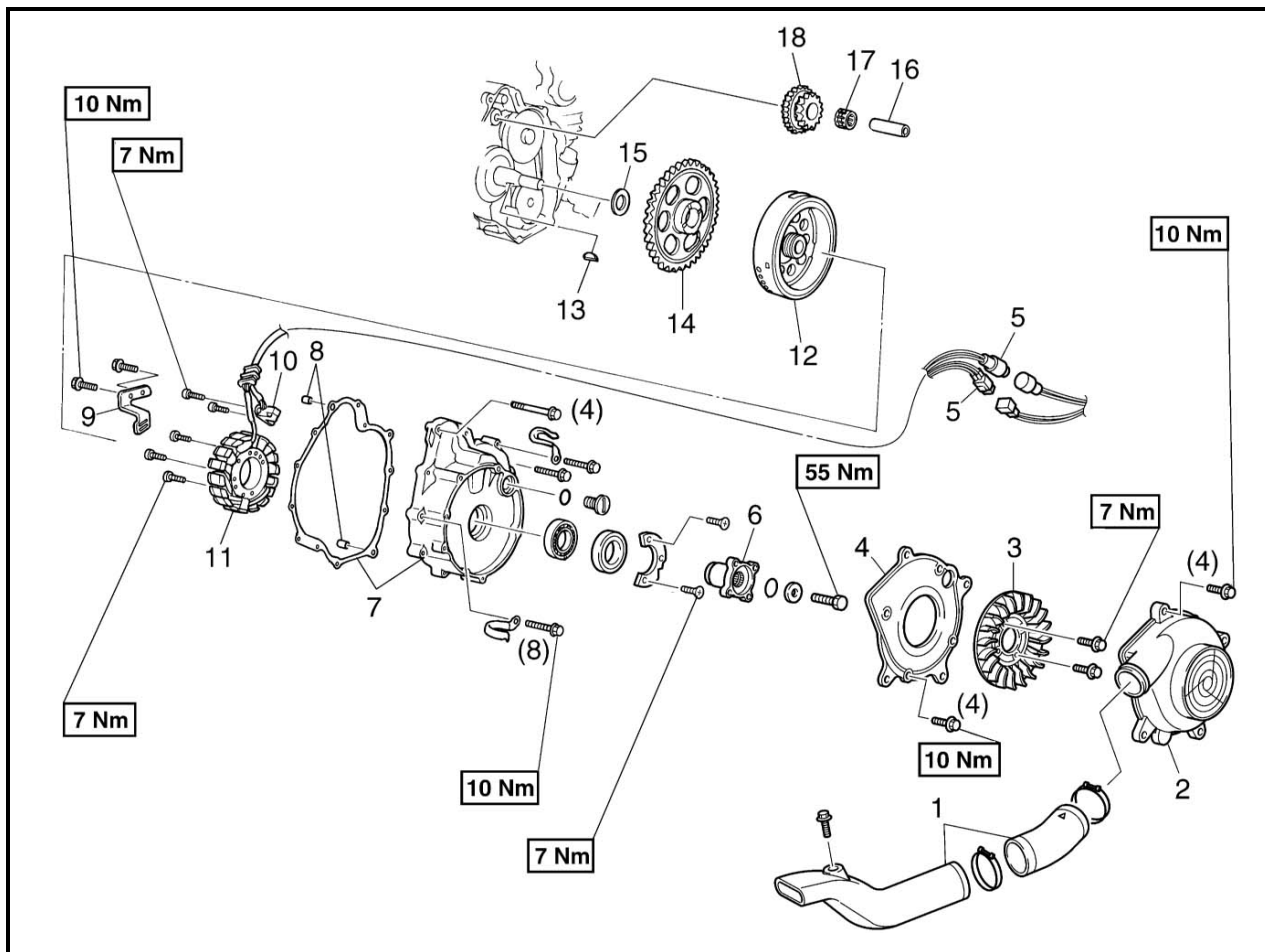

No.	Part Name	Qty	Remarks
	<b>Removing the engine cooling fan and A.C. magneto</b>		Remove the parts in the order listed.
	Drive belt cover		
	Engine oil		
	Coolant		
	Water pump assembly		
1	Engine cooling fan air duct assembly	1	
2	Air shroud 1	1	
3	Engine cooling fan	1	
4	Air shroud 2	1	
5	A.C. magneto coupler	2	
6	Engine cooling fan pulley base	1	
7	A.C. magneto cover/gasket	1/1	
8	Dowel pin	2	
9	Stator lead holder	1	

# ENGINE

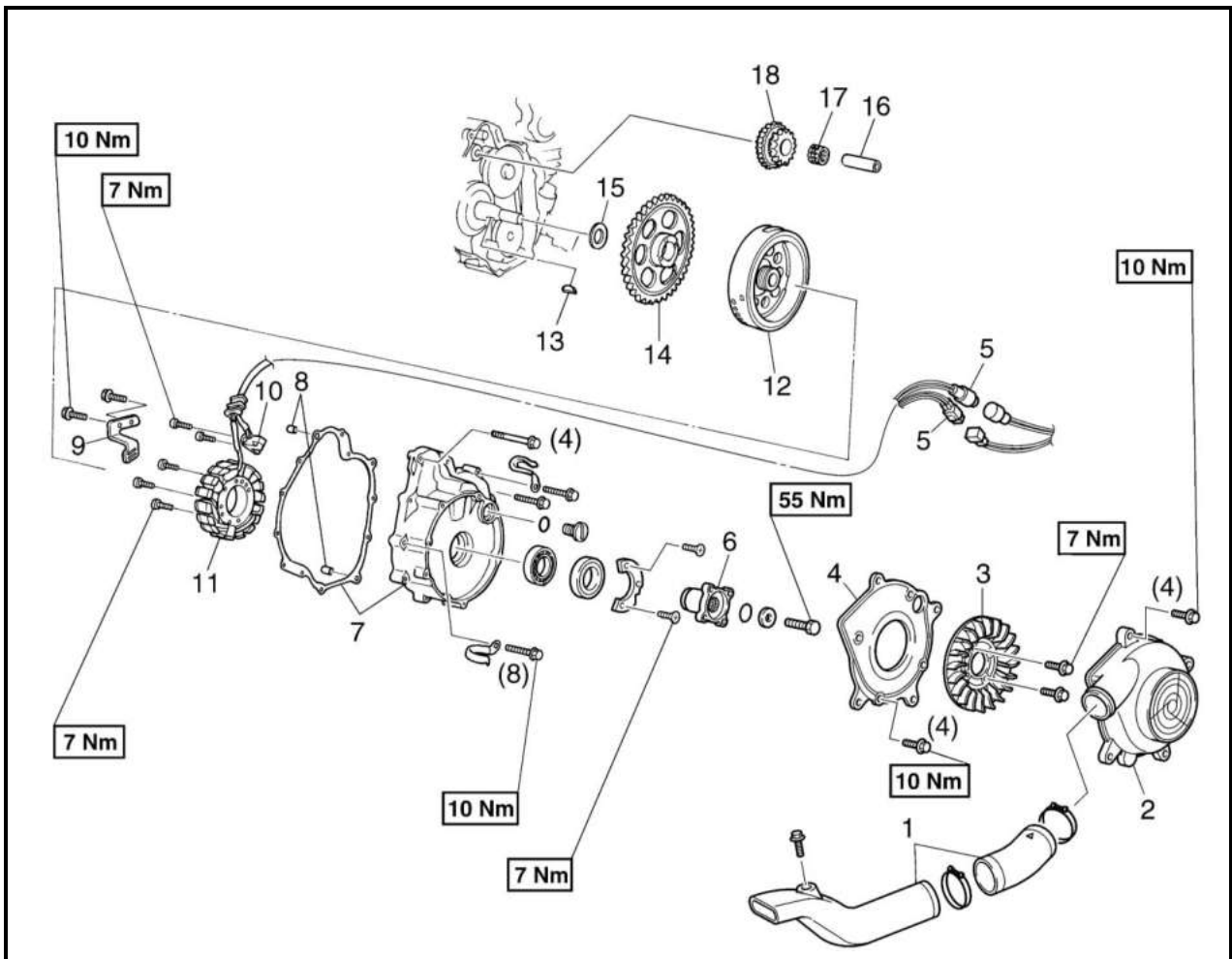

No.	Part Name	Qty	Remarks
10	Pickup coil	1	For installation, reverse the removal procedure.
11	Stator assembly	1	
12	A.C. magneto rotor	1	
13	Woodruff key	1	
14	Starter wheel gear	1	
15	Washer	1	
16	Starter idle gear shaft	1	
17	Bearing	1	
18	Starter idle gear	1	

## ENGINE

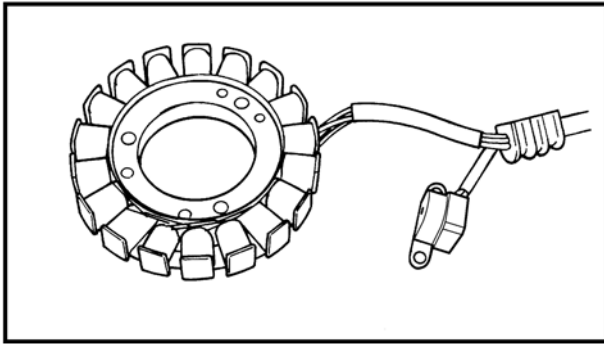

### 1、 CHECK

#### 1). Checking the A.C. magneto

- stator coil
  - pickup coil
- Damage → Replace.

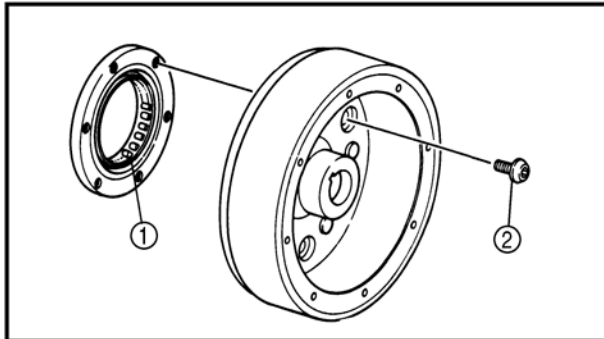

#### 2). Checking the starter clutch

- starter clutch ①  
Cracks/damage → Replace.
- starter clutch bolts ②  
Loose → Replace with new ones, and clinch the end of the bolts.

### **NOTE:**

- The arrow mark on the starter clutch must face inward, away from the A.C. magneto rotor.
- When installing, apply the locking agent.

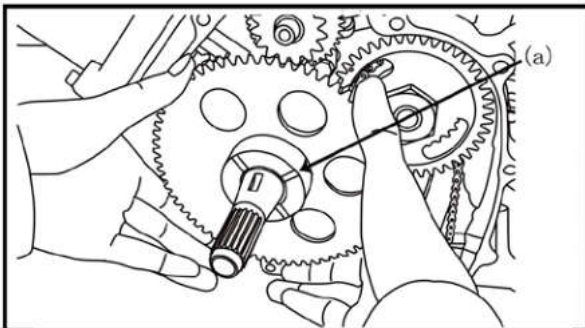

- a. Install the starter wheel gear onto the starter clutch, and hold the starter clutch.

### **NOTE:**

- Install the starter wheel gear with the groove (a) facing the A.C. magneto rotor.

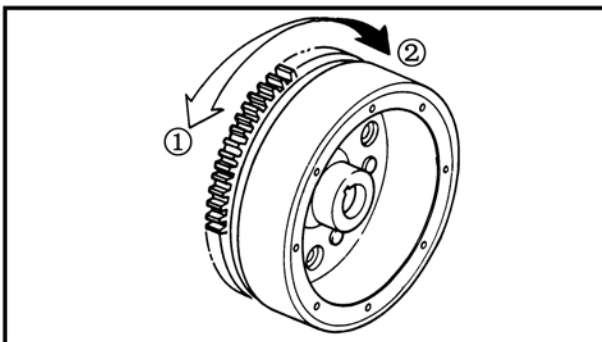

- b. Turn the starter wheel gear counterclockwise ① to check that the starter clutch and wheel gear engage.  
If the starter clutch and wheel gear do not engage, replace the starter clutch.
- c. Turn the starter wheel gear clockwise ② to check the starter wheel gear for smooth operation.  
If operation is not smooth, replace the starter clutch.

# ENGINE

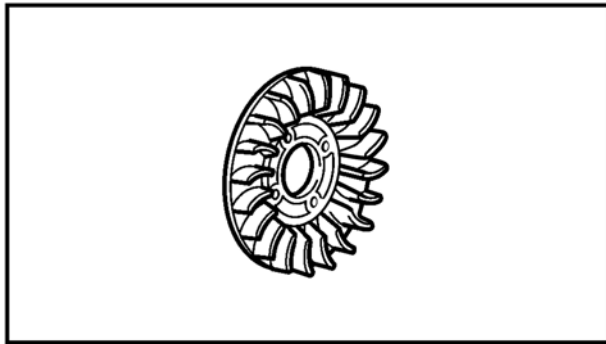
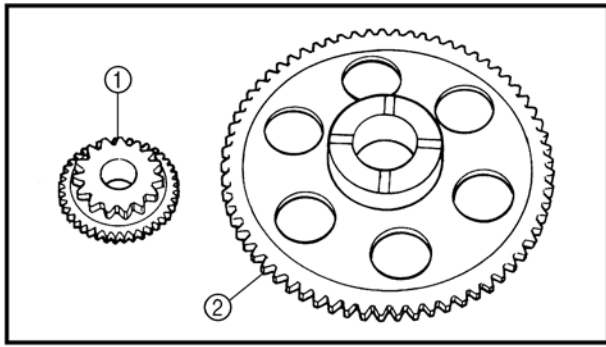

- starter idle gear teeth ①
  - starter wheel gear teeth ②
- Burrs/clips/roughness/wear → Replace.
- starter wheel gear (contacting surface)
- Damage/pitting/wear → Replace.

### 3). Checking the engine cooling fan

- engine cooling fan
  - air shroud 1
  - air shroud 2
- Cracks/damage → Replace.

## 2. INSTALL

- woodruff key
- A.C. magneto rotor

### **NOTE:**

- **Before installing the rotor, clean the outside of the crankshaft and the inside of the rotor.**
- **After installing the rotor, check that the rotor rotates smoothly. If not, reinstall the key and rotor.**

- dowel pins
- gasket (New replacement)
- A.C. magneto cover(10Nm)

### **NOTE:**

- **When installing the A.C. magneto cover, use a long rod to hold the A.C. magneto rotor in position from the outside. This will make assembly easier. Be careful not to damage the oil seal.**
- **Apply sealant (Quick Gasket) ① to the thread of the bolt ② shown in the illustration.**
- **Tighten the bolts in stages, using a crisscross pattern.**

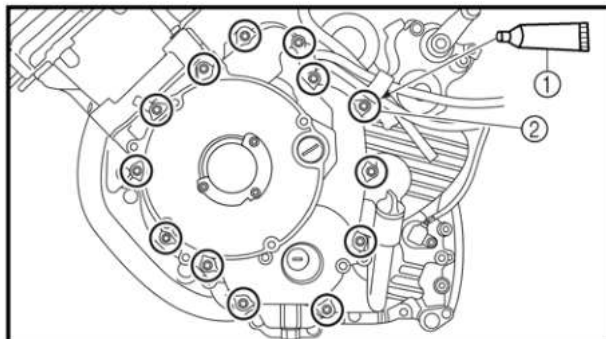

- engine cooling fan pulley ①(55Nm)



## ENGINE

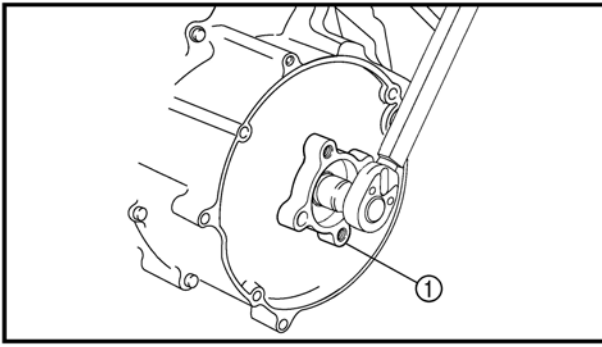

**NOTE:**

Before installing the engine cooling fan pulley, do not forget to install the O-ring.

- engine cooling fan ① (7Nm)

**NOTE:**

Install the bolts in the holes in the collar of the engine cooling fan.

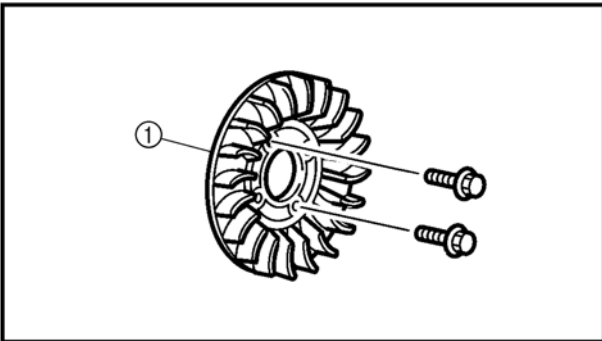

- air shroud ① (10Nm)
- engine cooling fan air duct assembly ①

**NOTE:**

Install the engine cooling fan air duct assembly with the arrow mark (a) towards the air shroud ①.

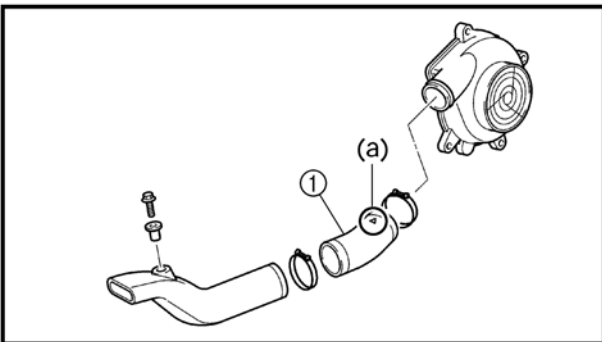

# ENGINE

## BALANCER GEARS AND OIL PUMP GEARS

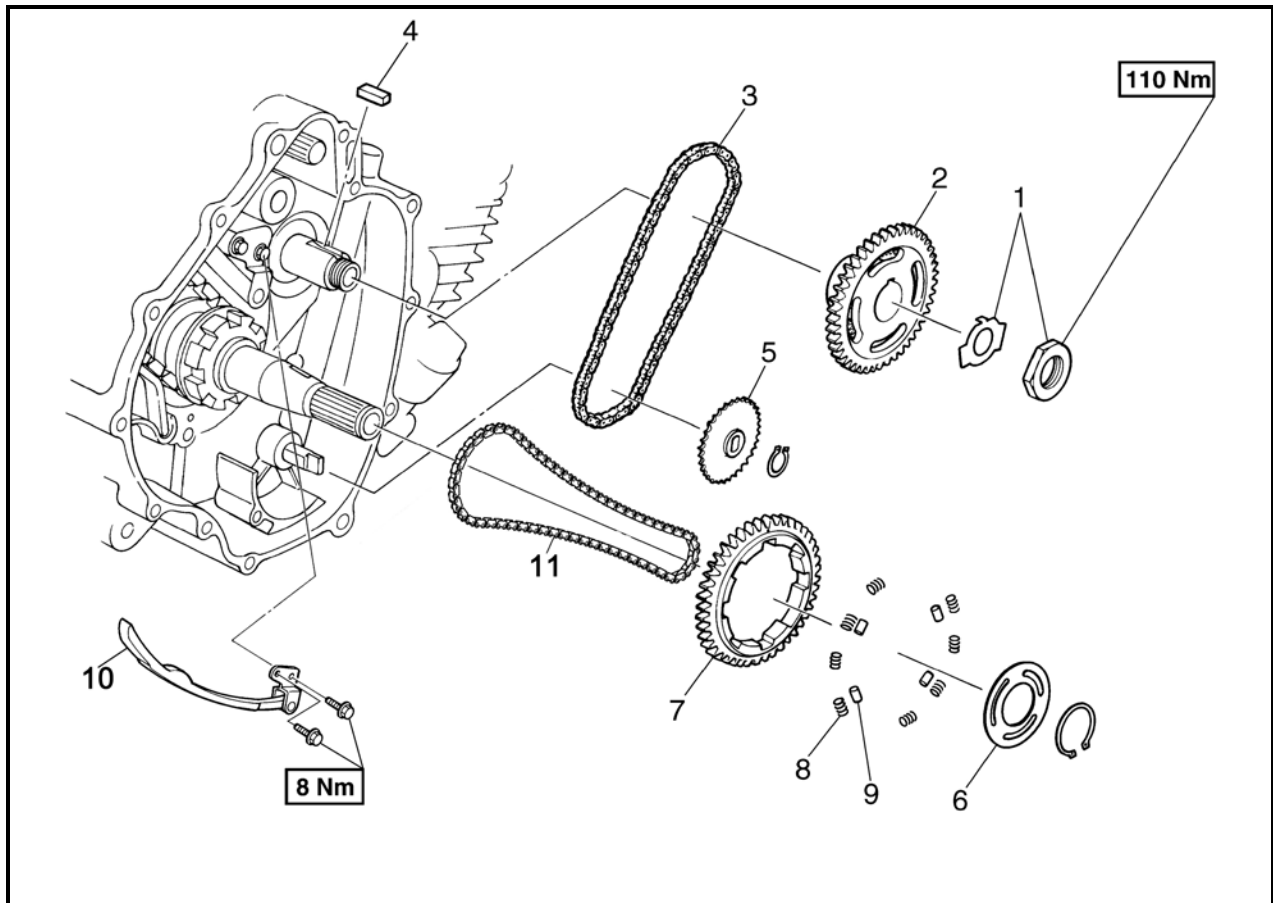

No.	Part Name	Qty	Remarks
	<b>Removing the balancer gears and oil pump gears</b>		Remove the parts in the order listed.
1	Nut/lock washer	1/1	
2	Balancer driven/oil pump drive gear	1	
3	Chain	1	
4	Straight key	1	
5	Oil pump driven gear	1	
6	Plate	1	
7	Balancer drive gear	1	
8	Spring	8	
9	Pin	4	
10	Timing chain guide (intake side)	1	
11	Timing chain	1	
			For installation, reverse the removal procedure.

## ENGINE

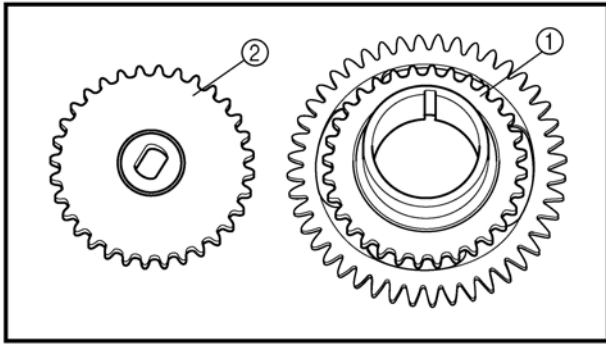

### 1、 CHECK

1) Checking the oil pump drive gear and oil pump driven gear

- oil pump drive gear ①
  - oil pump driven gear ②
- Cracks/wear/damage → Replace

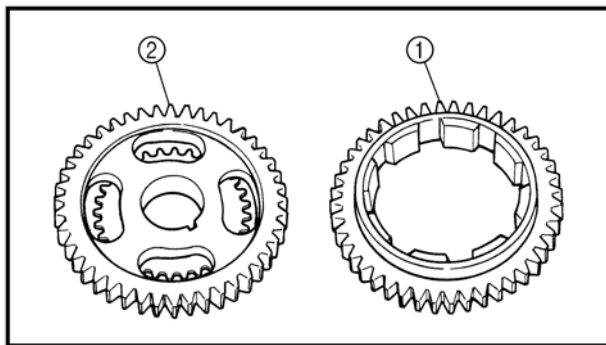

2).Checking the balancer drive gear and balancer driven gear

- balancer drive gear ①
- balancer driven gear ②

Damage/wear → Replace the balancer drive gear and balancer driven gear as a set.

Excessive noise during operation → Replace the balancer drive gear and balancer driven gear as a set.

3). Checking the timing chain and guides

- timing chain

Cracks/stiff → Replace the timing chain and camshaft sprocket as a set.

- timing chain guides

Wear/damage → Replace.

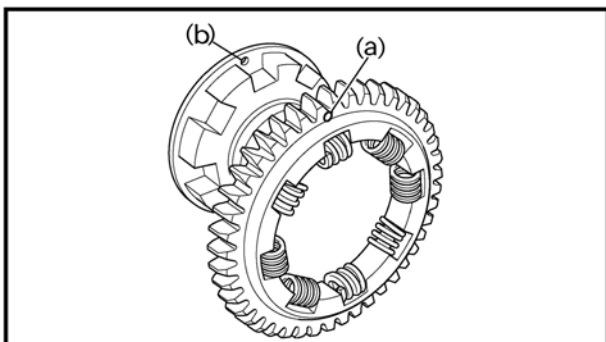
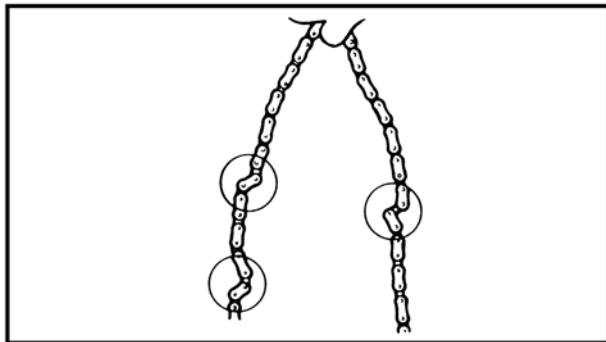

### 2、 INSTALL

- pins
- springs
- balancer drive gear (onto the buffer boss)
- plate
- circlip

#### **NOTE:**

Align the punch mark (a) on the balancer drive gear with the hole (b) to the buffer boss.

## ENGINE

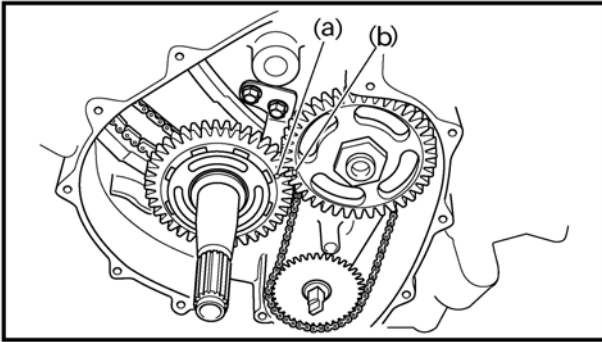

- balancer driven gear

---

**NOTE:**

Align the punch mark (a) on the balancer drive gear with the punch mark (b) on the balancer driven gear.

---

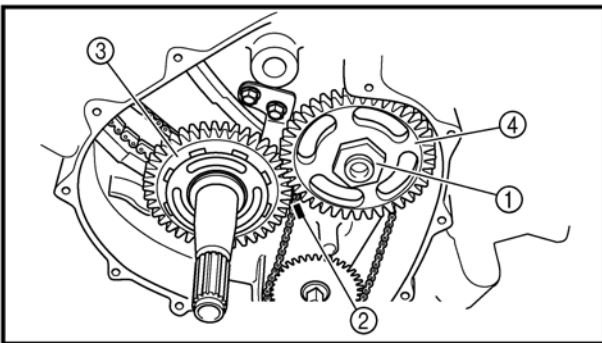

- lock washer(new replacement)
- balancer driven gear nut ①(110Nm)

---

**NOTE:**

- Place an aluminum plate ② between the teeth of the balancer drive gear ③ and balancer driven gear ④.
  - Apply the molybdenum disulfide grease to the thread of axle and nut.
-

# ENGINE

## PRIMARY AND SECONDARY SHEAVES

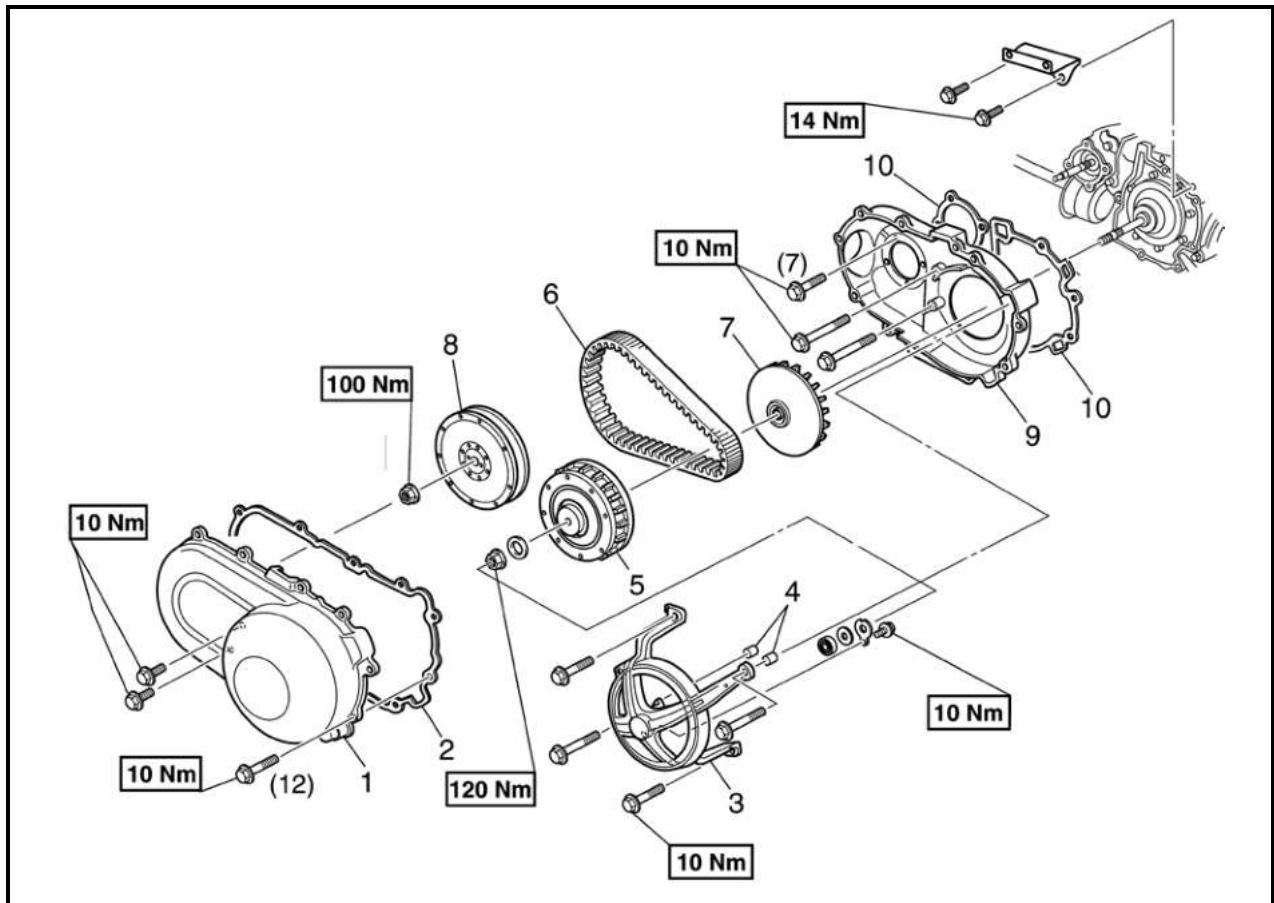

No.	Part Name	Qty	Remarks
	<b>Removing the primary and secondary sheaves</b>		Remove the parts in the order listed.
	Engine assembly		
1	Drive belt cover	1	
2	Rubber gasket	1	
3	Bearing housing	1	
4	Dowel pin	2	
5	Primary sheave assembly	1	
6	V-belt	1	
7	Primary fixed sheave	1	
8	Secondary sheave assembly	1	
9	Drive belt case	1	
10	Rubber gasket	2	
			For installation, reverse the removal procedure.

# ENGINE

## PRIMARY SHEAVE

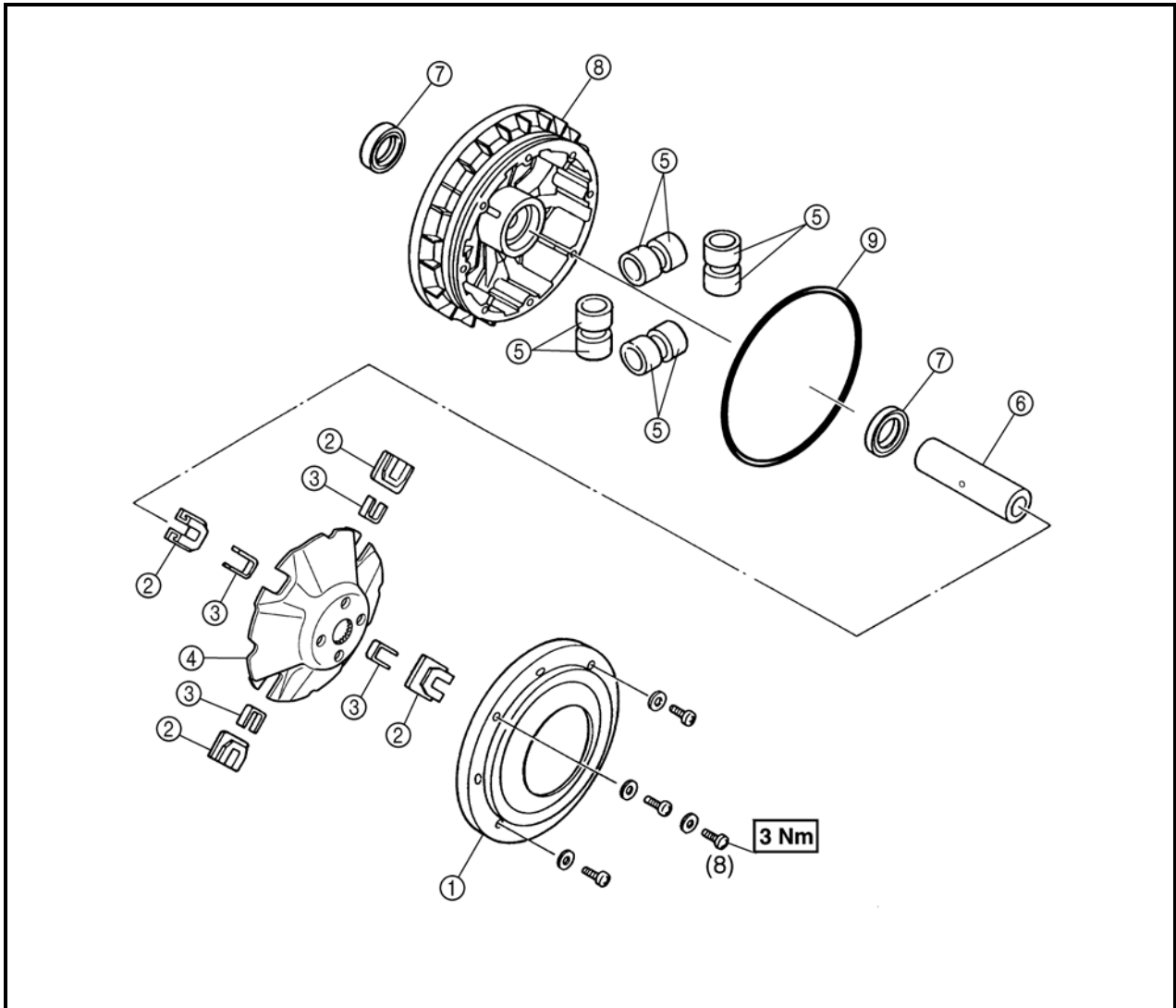

No.	Part Name	Qty	Remarks
	<b>Disassembling the primary sheave</b>		Remove the parts in the order listed.
①	Primary pulley sheave cap	1	
②	Primary pulley slider	4	
③	Spacer	4	
④	Primary pulley cam	1	
⑤	Primary pulley weight	8	
⑥	Collar	1	
⑦	Oil seal	2	
⑧	Primary sliding sheave	1	
⑨	O-ring	1	
			For assembly, reverse the disassembly procedure.

# ENGINE

## SECONDARY SHEAVE

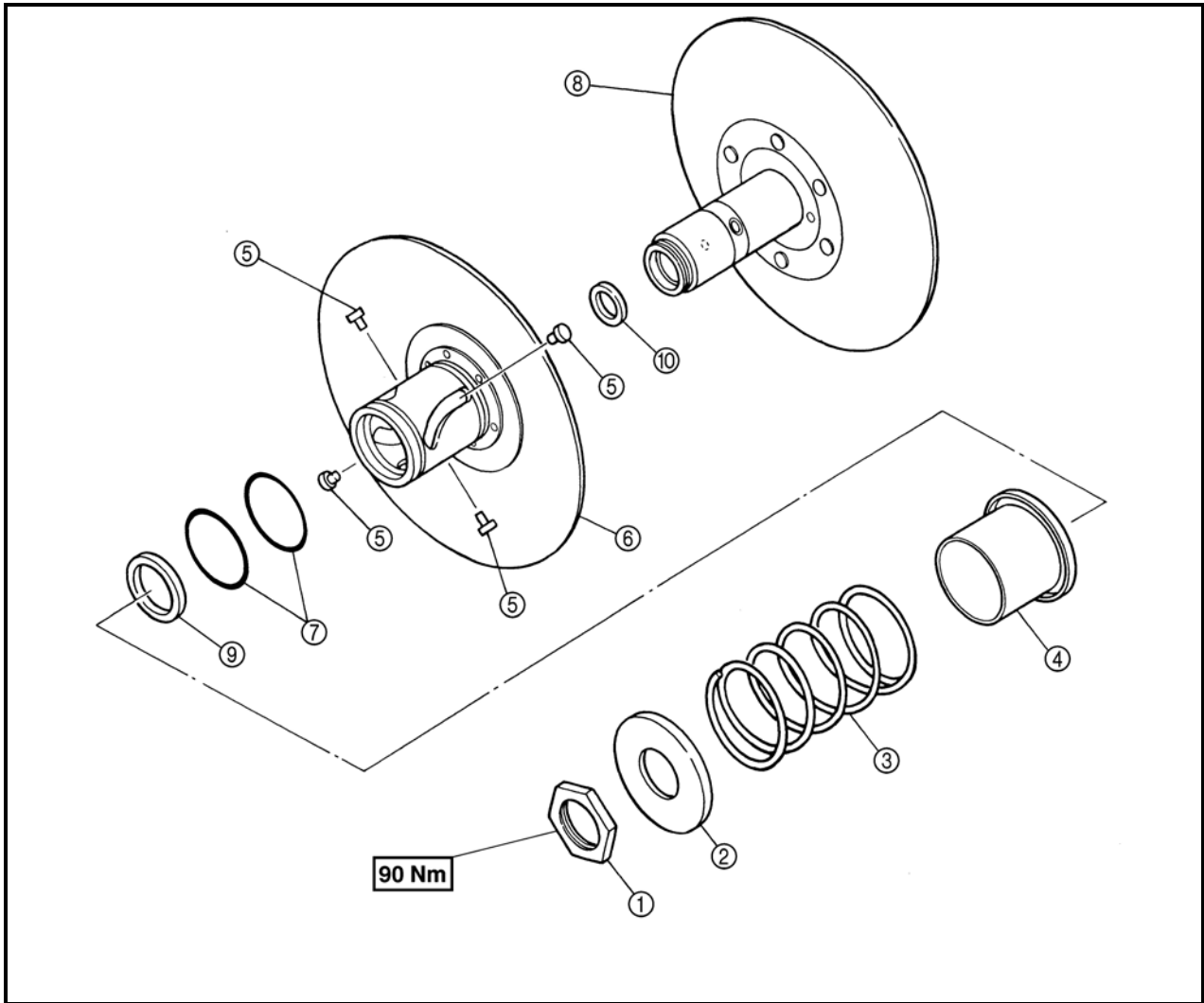

No.	Part Name	Qty	Remarks
	<b>Disassembling the secondary Sheave</b>		Remove the parts in the order listed.
①	Nut	1	
②	Spring seat	1	
③	Compression spring	1	
④	Spring seat	1	
⑤	Guide pin	4	
⑥	Secondary sliding sheave	1	
⑦	O-ring	2	
⑧	Secondary fixed sheave	1	
⑨	Oil seal	1	
⑩	Oil seal	1	
			For assembly, reverse the disassembly procedure.

# ENGINE

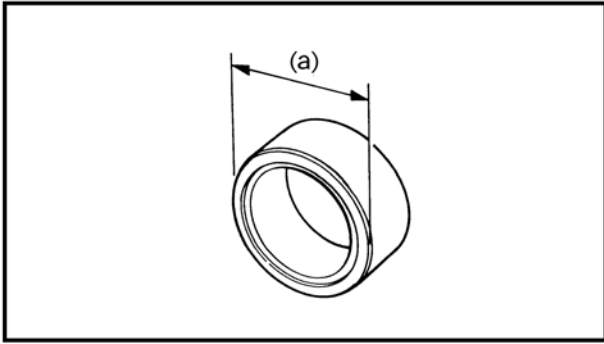

## 1、 Check

### 1). Checking the primary sheave

- weight outside diameter (a)  
Out of specification → Replace the weight.

**Weight outside diameter limit: 29.5 mm**

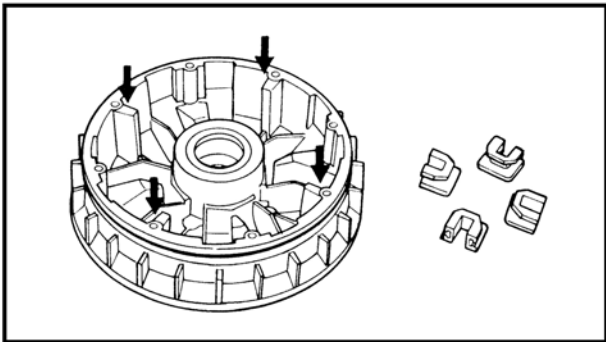

- primary pulley slider
- primary sliding sheave splines  
Wear/cracks/damage → Replace.
- spacer
- primary pulley cam  
Cracks/damage → Replace.

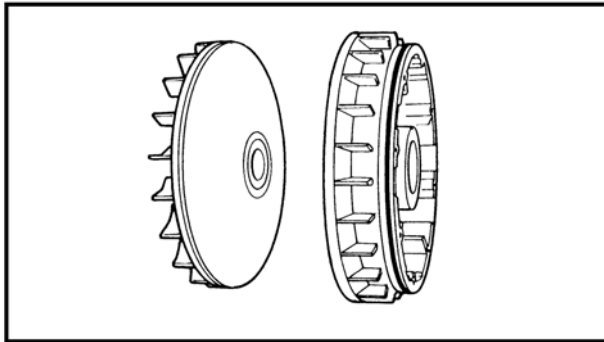

- primary sliding sheave
- primary fixed sheave  
Cracks/damage → Replace.

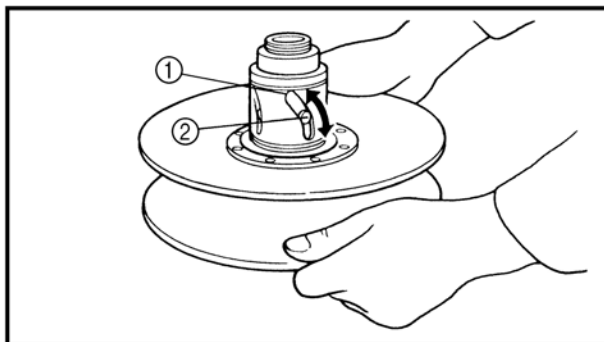

### 2). Checking the secondary sheave

- secondary fixed sheave smooth operation
- secondary sliding sheave smooth operation  
Scratches/damage → Replace as a set.
- torque cam grooves ①  
Wear/damage → Replace
- guide pins ②  
Wear/damage → Replace.
- secondary sheave spring  
Damage → Replace.



## ENGINE

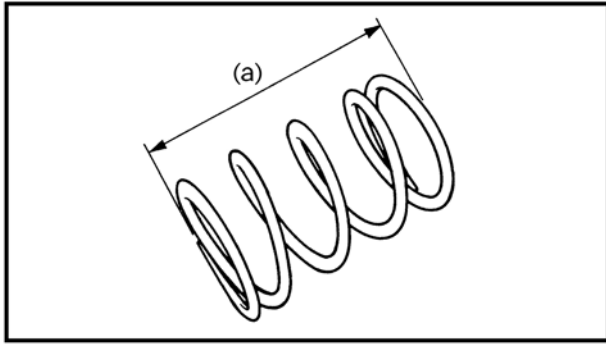

### 2、 Measure

- secondary sheave spring free length (a)
- Out of specification → Replace the secondary sheave spring.

### 3、 INSTALL

#### 1). Assembling the primary sheave

##### (1)Clean:

- primary sliding sheave face ①
- primary fixed sheave face ②
- collar ③
- weights ④
- primary sliding sheave cam face

##### **NOTE:**

Remove any excess grease.

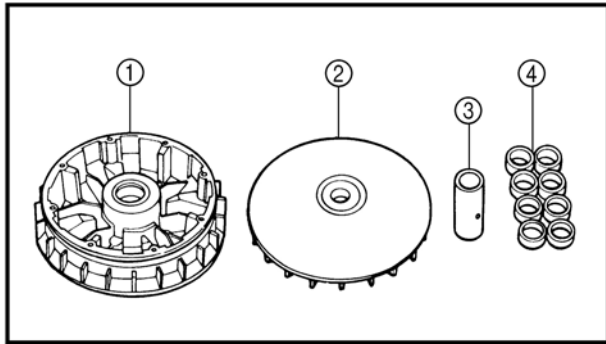

##### (2)Install:

- weights ①

##### **NOTE:**

- Apply grease (90g) to the whole outer surface of the weights and install.
- Apply grease to the inner surface of the collar.
- Apply grease to the inner surface of the primary sliding sheave.

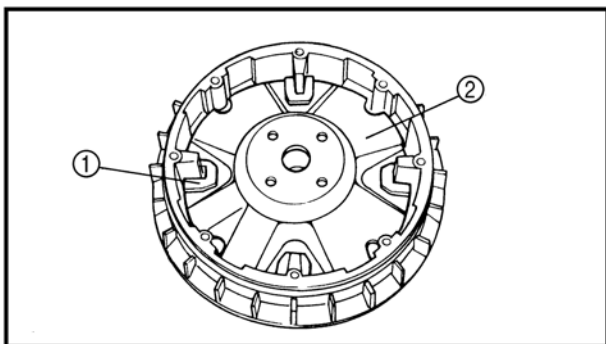
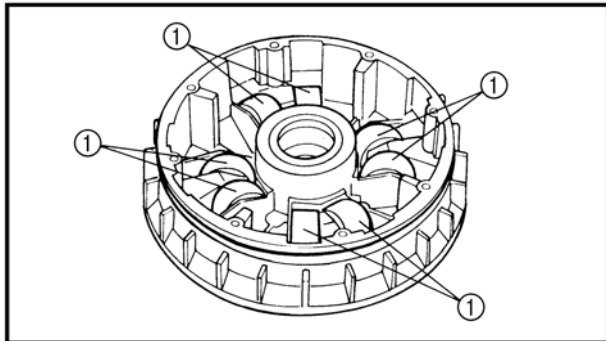

- spacer
- sliders ①
- primary pulley cam ②
- primary sliding sheave cap (3 Nm)

## ENGINE

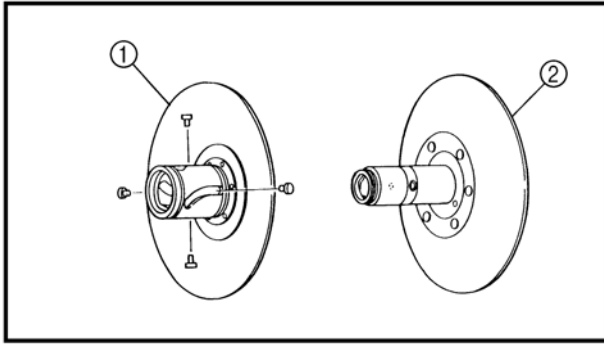

### 2). Assembling the secondary sheave

#### (1)Apply:

- assembly lube  
(to the secondary sliding sheave ① inner surface and oil seals).
- assembly lube  
(to the bearings, oil seals and inner surface of the secondary fixed sheave ②)

#### (2)Install:

- guide pins ①
- spring seat
- compression spring
- spring seat
- nut

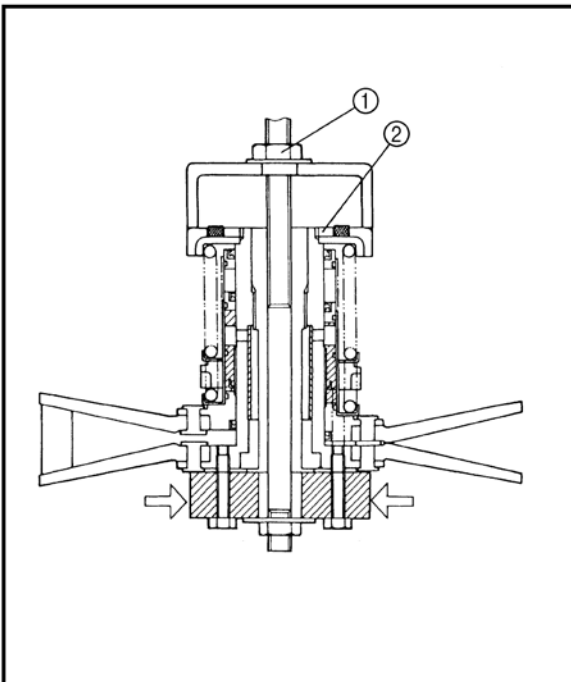
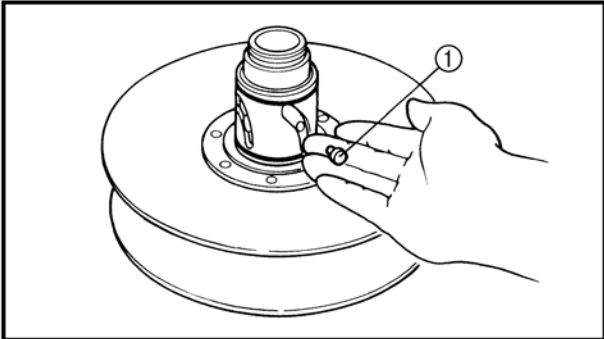

- a. Attach the sheave fixed block, locknut wrench and sheave spring compressor to the secondary sheave assembly.
- b. Place the sheave fixed block in a vise and secure it.
- c. Tighten the sheave spring compressor nut ① and compress the spring.
- d. Install the nut  torque using the locknut wrench.(Nut:90Nm)
- e. Remove the sheave spring compressor, locknut wrench, and sheave fixed block.

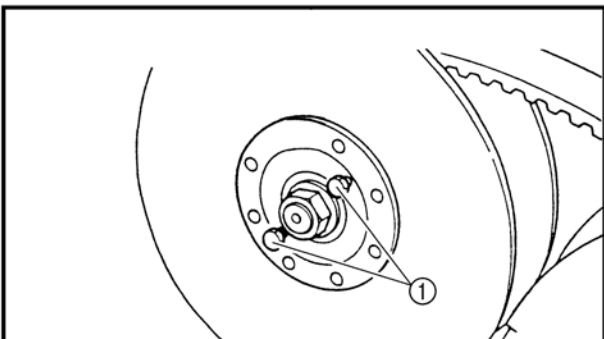

### 3). Installing the primary and secondary sheaves

#### (1) Install:

- secondary sheave assembly
- V-belt
- primary sheave assembly

## ENGINE

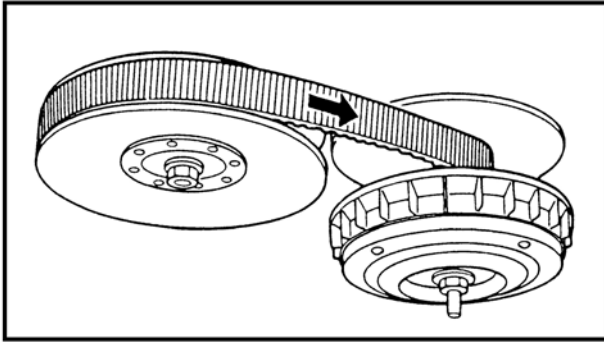

---

**NOTE:**

- Tightening the bolts ① will push the secondary sliding sheave away, causing the gap between the secondary fixed and sliding sheaves to widen.
  - Install the V-belt so that its arrow faces the direction show in the illustration.
- 

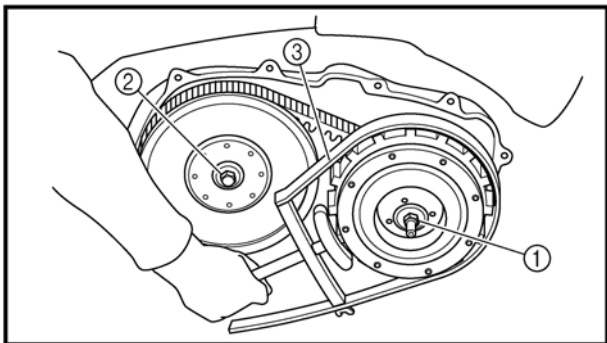

(2)Tighten:

- primary sheave nut ①(120Nm)
- secondary sheave nut ②(100Nm)

---

**NOTE:**

- Use the sheave holder ③ to hold the primary sheave.
  - First, tighten the primary sheave nut ①, then tighten the secondary sheave nut ②.
-

# ENGINE

## CLUTCH

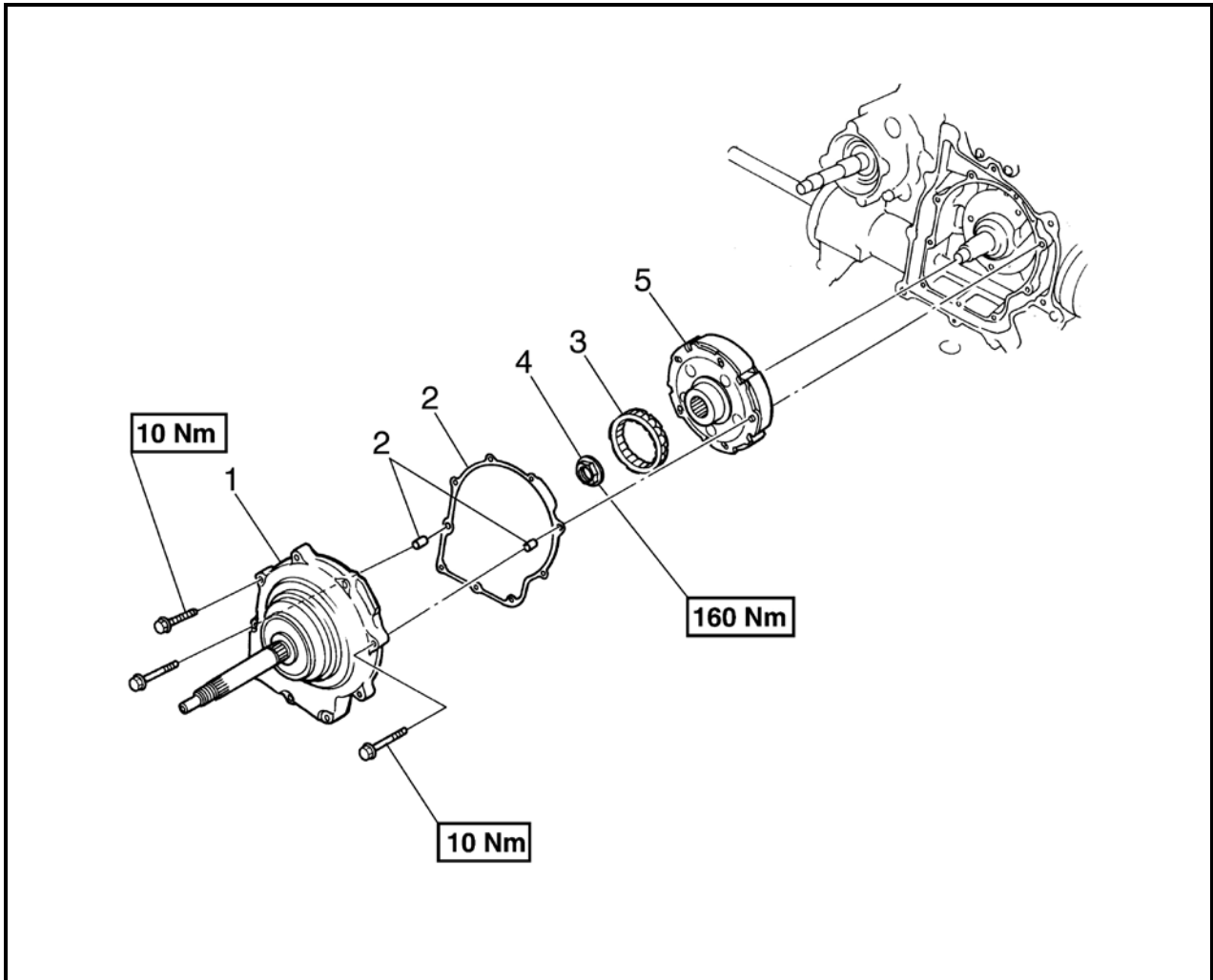

No.	Part Name	Qty	Remarks
	<b>Removing the clutch</b>		Remove the parts in the order listed.
	Primary and secondary sheaves		
1	Clutch housing assembly	1	
2	Gasket/dowel pin	1/2	
3	One-way clutch bearing	1	
4	Nut	1	
5	Clutch carrier assembly	1	
			For installation, reverse the removal procedure.

# ENGINE

## CLUTCH HOUSING

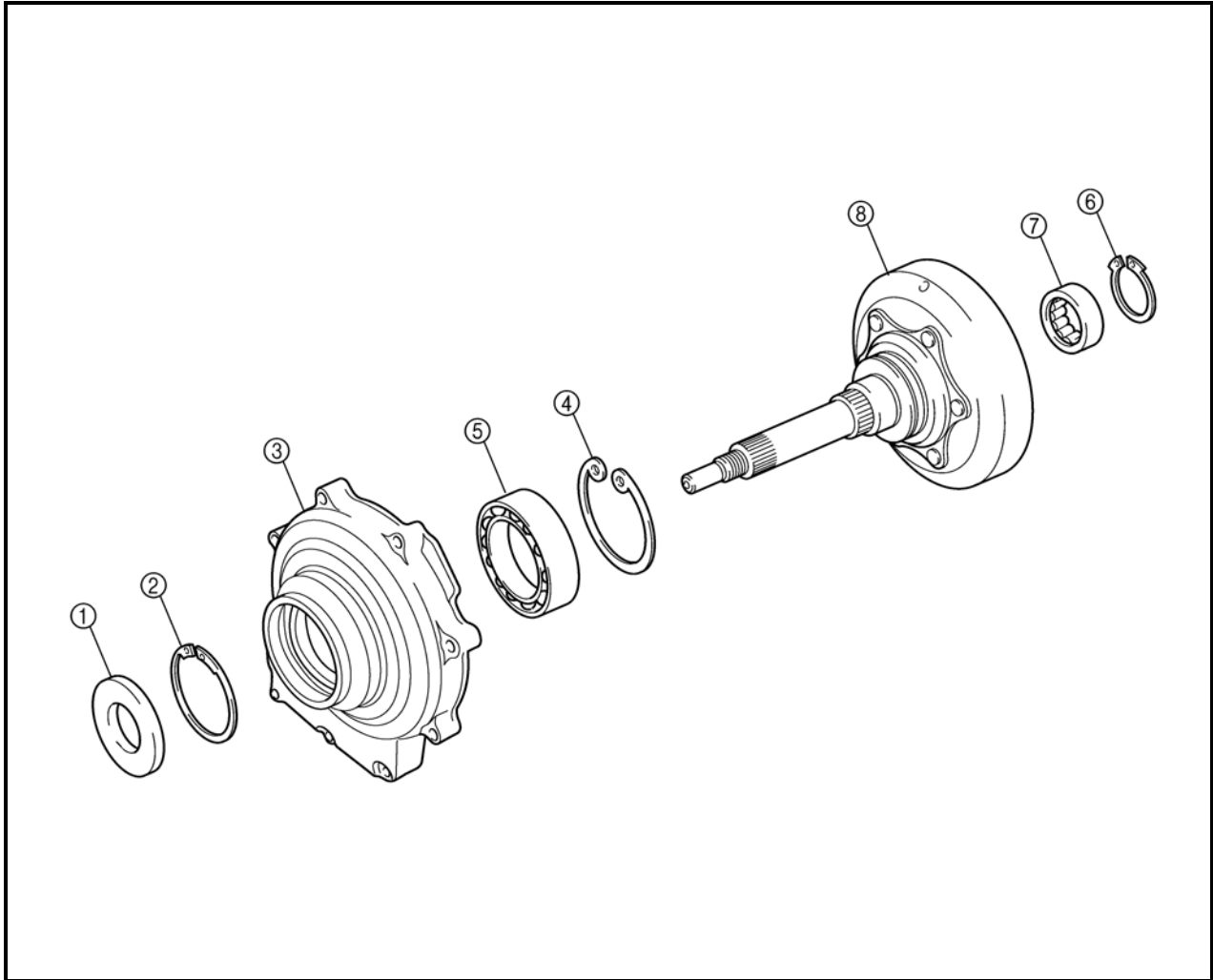

No.	Part Name	Qty	Remarks
	<b>Disassembling the clutch housing</b>		Remove the parts in the order listed.
①	Oil seal	1	
②	Circlip	1	
③	Bearing housing	1	
④	Circlip	1	
⑤	Bearing	1	
⑥	Circlip	1	
⑦	Bearing	1	
⑧	Clutch housing	1	
			For assembly, reverse the disassembly procedure.

## ENGINE

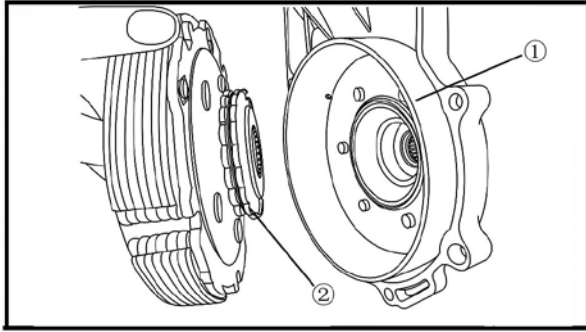

### 1、 CHECK

#### 1). Checking the clutch

- clutch housing ①  
Heat damage/wear/damage → Replace.
- one-way clutch bearing ②  
Chafing/wear/damage → Replace.

#### **NOTE:**

- **Replace the one-way clutch assembly and clutch housing as a set.**
- **The one-way clutch bearing must be installed with the flange side facing in.**

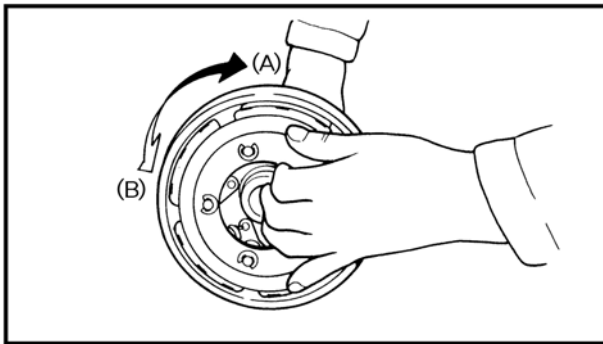

- Install the one-way clutch bearing and clutch carrier assembly to the clutch housing and hold the clutch carrier assembly.
  - When turning the clutch housing clockwise (A), the clutch housing should turn freely. If not, the one-way clutch assembly is faulty. Replace it.
  - When turning the clutch housing counter-clockwise (B), the clutch housing and crankshaft should be engaged. If not, the one-way clutch assembly is faulty. Replace it.
- clutch shoe  
Heat damage → Replace.

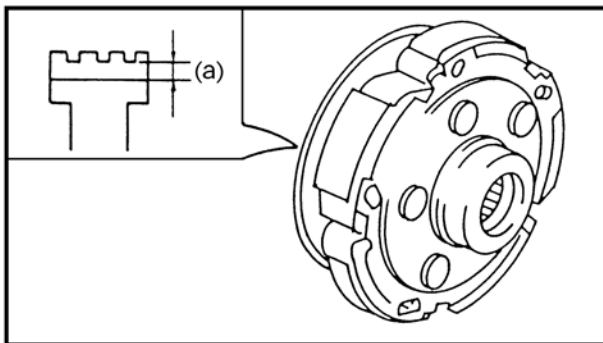

### 2、 MEASURE

- clutch shoe thickness  
Out of specification → Replace.

**Clutch shoe wear limit (a)**

**1.0 mm**

## ENGINE

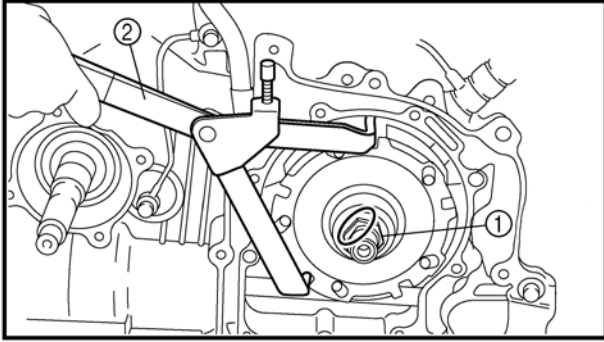

### 3、INSTALL

- clutch carrier assembly
- nut ①(160Nm)

#### **NOTE:**

Use a universal clutch holder ②  
clutch carrier assembly.

- Lock the threads with a drift punch.

- one-way clutch bearing

#### **NOTE:**

The one-way clutch bearing should be installed in the clutch carrier assembly with the arrow mark (a) facing toward the clutch housing.

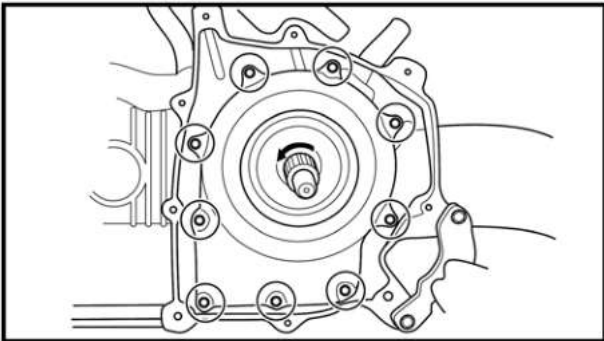
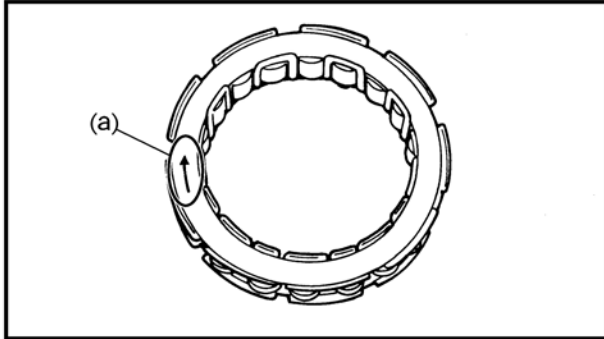

- dowel pins
- gasket
- clutch housing assembly  
(10 Nm)

#### **NOTE:**

- Tighten the bolts in stages, using a crisscross pattern.
- After tightening the bolts, check that the clutch housing assembly to counterclockwise rotates smoothly.

# ENGINE

## CRANKCASE

### Starter motor and oil filter

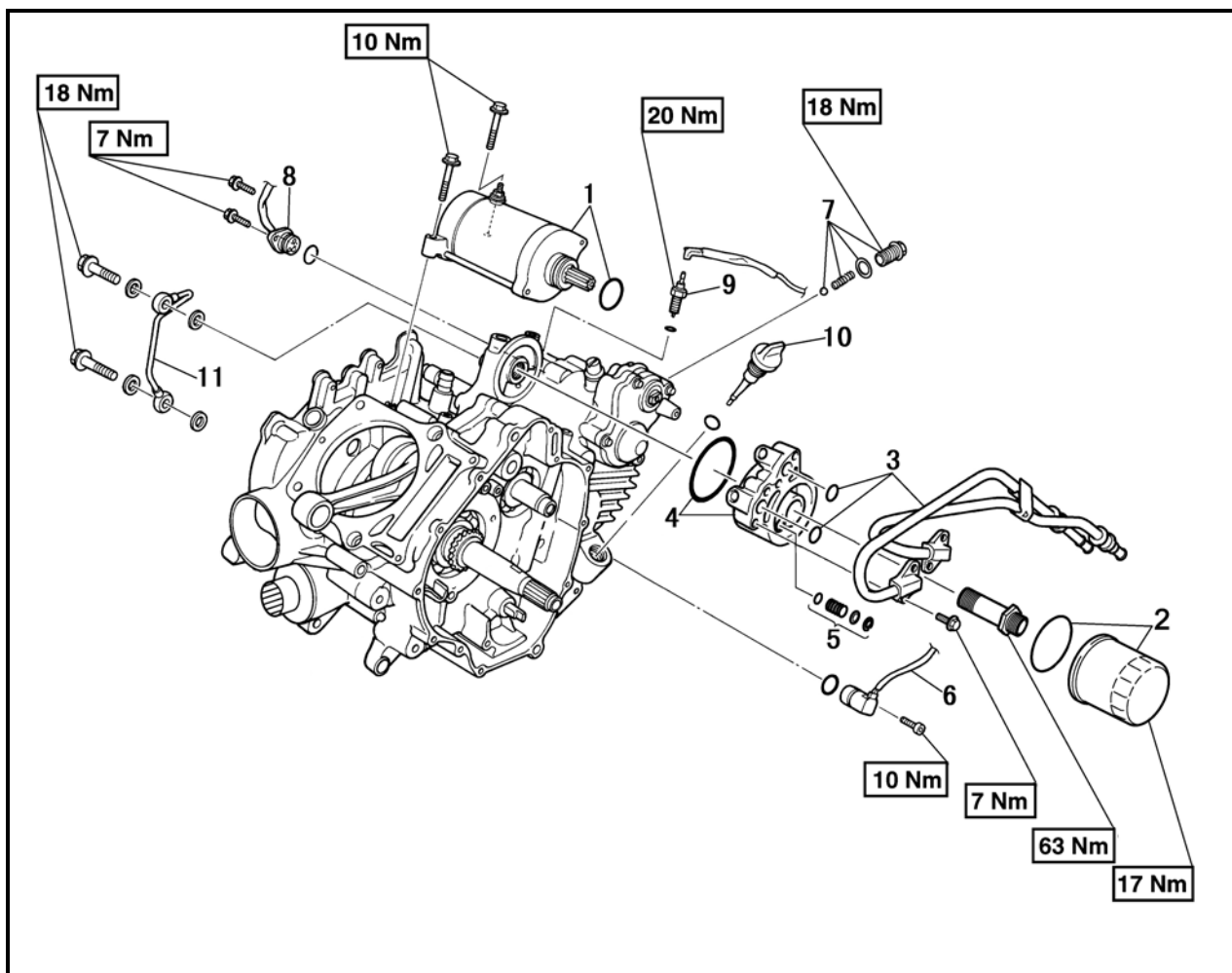

No.	Part Name	Qty	Remarks
	<b>Remove the starter motor, timing chain and oil filter</b>		Remove the parts in the order listed.
	A.C. magneto rotor		
	Primary and secondary sheaves		
	Clutch carrier assembly		
1	Starter motor/O-ring	1/1	
2	Oil filter cartridge/O-ring	1	
3	Oil pipe assembly/O-ring	1/2	
4	Oil pipe adapter/O-ring	1/1	
5	Relief valve assembly	1	
6	Speed sensor	1	
7	Shift drum stopper	1	
8	Gear position switch	1	



# ENGINE

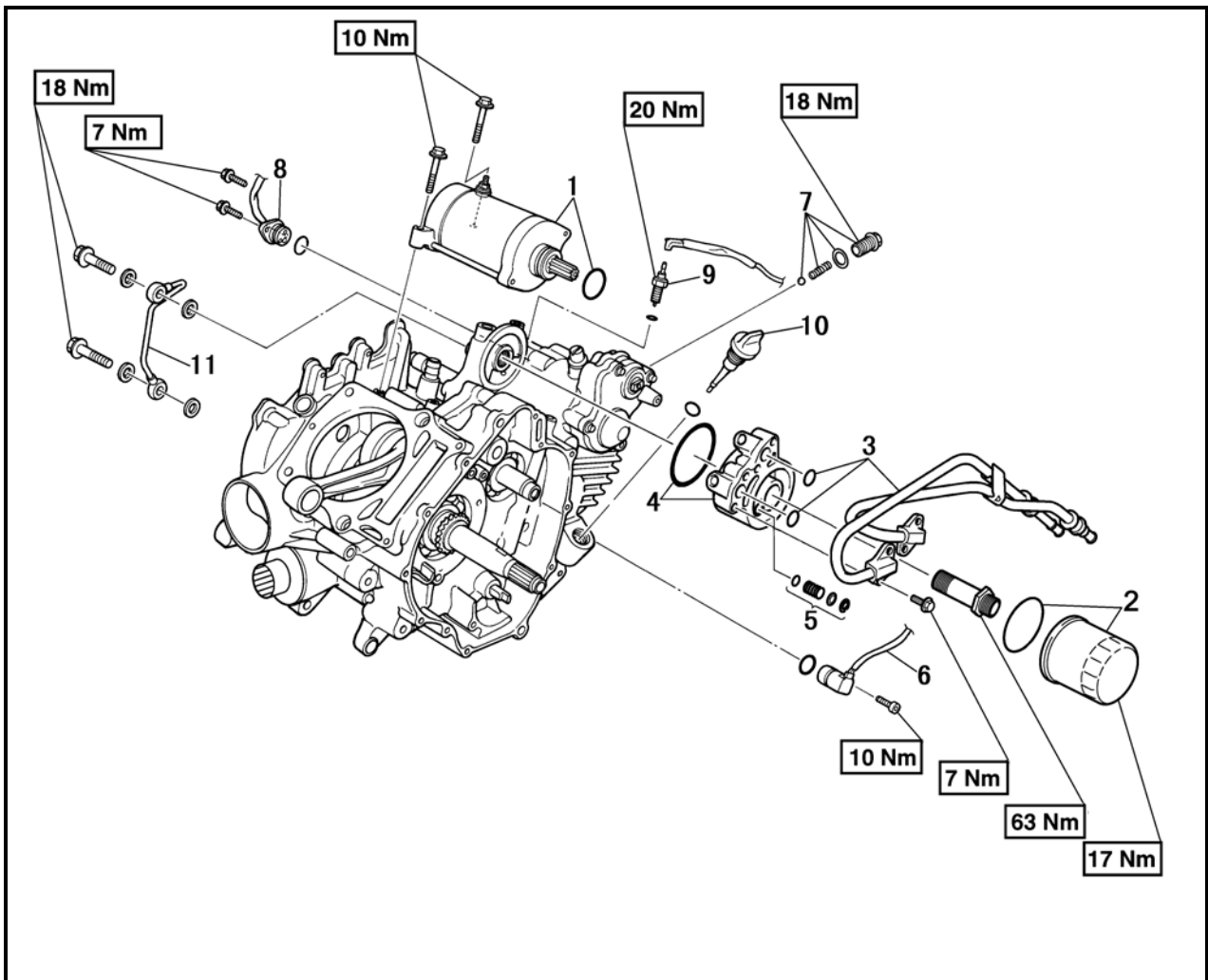

No.	Part Name	Qty	Remarks
9	Reverse switch	1	For installation, reverse the removal procedure.
10	Oil filler cap	1	
11	Oil delivery pipe 1	1	

# ENGINE

## Crankcase

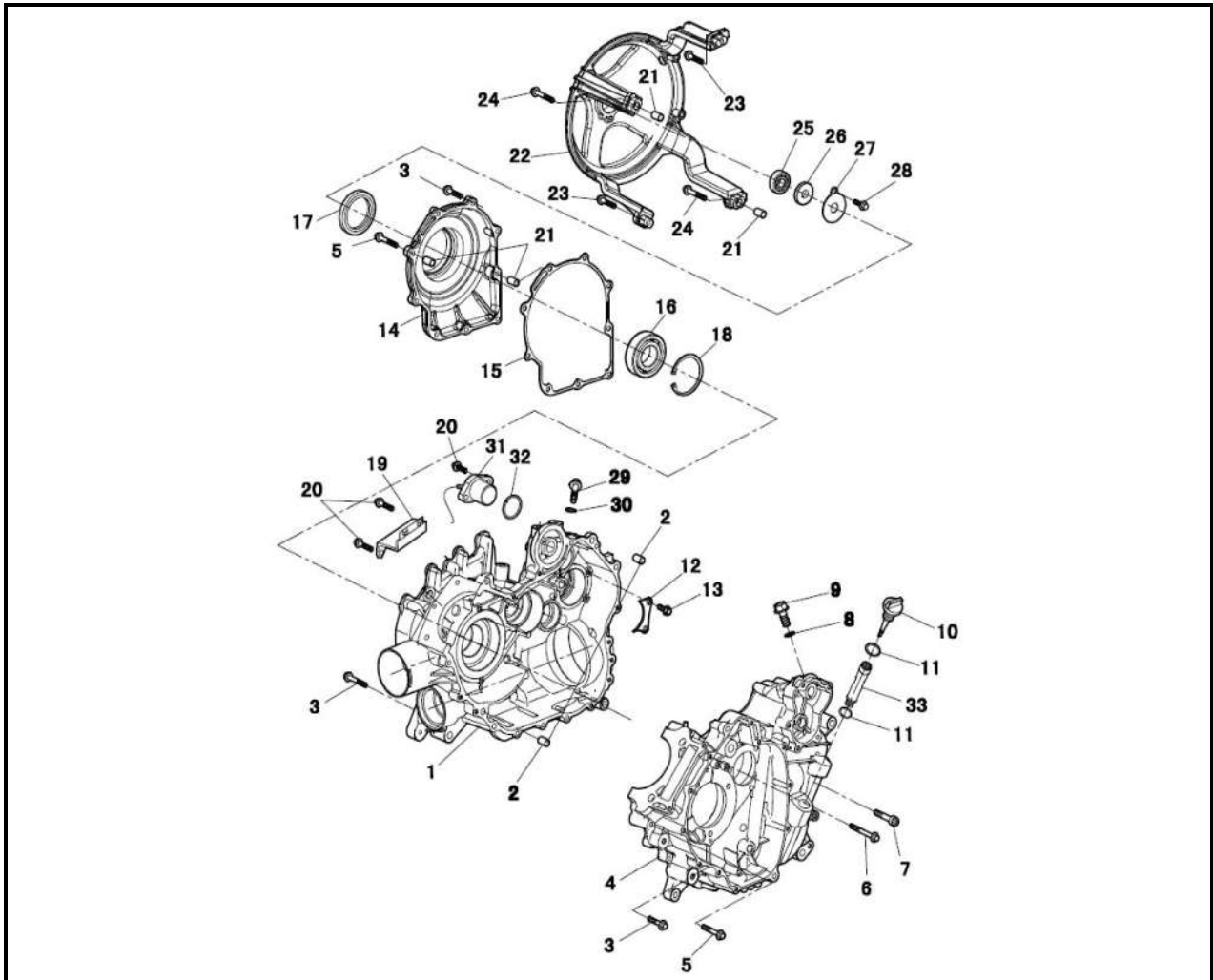

No.	Part Name	Qty	Remarks
	Separating the crankcase		Remove the parts in the order listed.
1	Right crankcase assy	1	
2	Pin, dowel 9×12×16	2	
3	Hexagon flange bolts m6×30	19	
4	Left crankcase assy	1	
5	Hexagon flange bolts m6×40	4	
6	Hexagon flange bolts m6×85	1	
7	Hexagon socket head cap screws M8×40	3	
8	Aluminum washer 14×22×1.5	1	
9	Hexagon flange screw plug M14×1.5×16	1	
10	Oil dipstck	1	
11	O-ring 18×3.5	1	
12	Press plate main shaft bearing	1	

# ENGINE

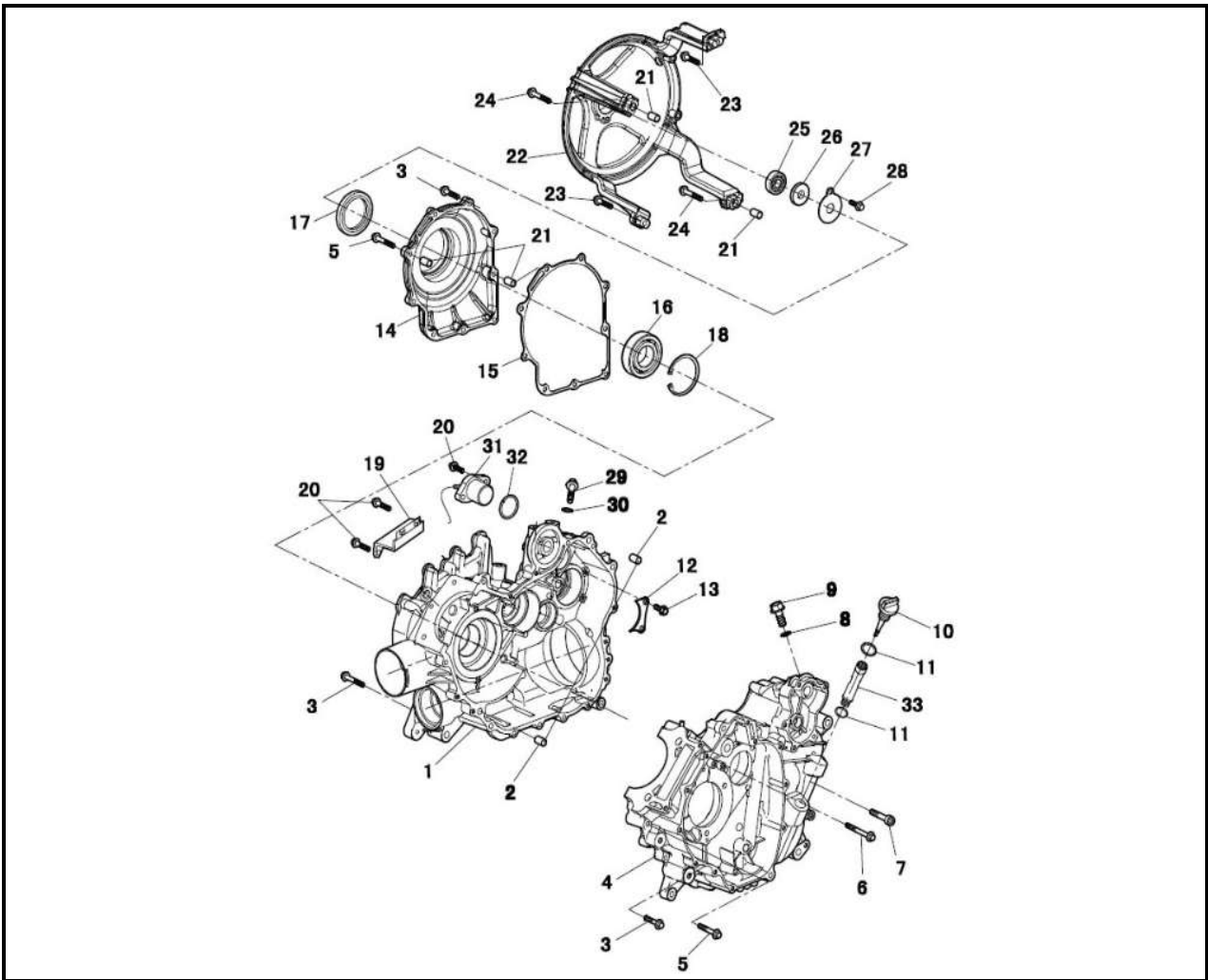

No.	Part Name	Qty	Remarks
13	Hexagon flange bolts m6×16	2	
14	Wet clutch case cover	1	
15	Gasket, wet clutch cover	1	
16	Bearing 16010	1	
17	Oil seal 35×65×9	1	
18	Circlip for hole ø80	1	
19	Bracket, cvt vent-pipe	1	
20	Hexagon head bolt and plain washer assemblies m6×16	2	
21	Pin, dowel 10×16	4	
22	Shield bracket, clutch	1	
23	Hexagon flange bolts m6×32	2	
24	Hexagon flange bolts m6×40	2	
25	Bearing 62012Z	1	

# ENGINE

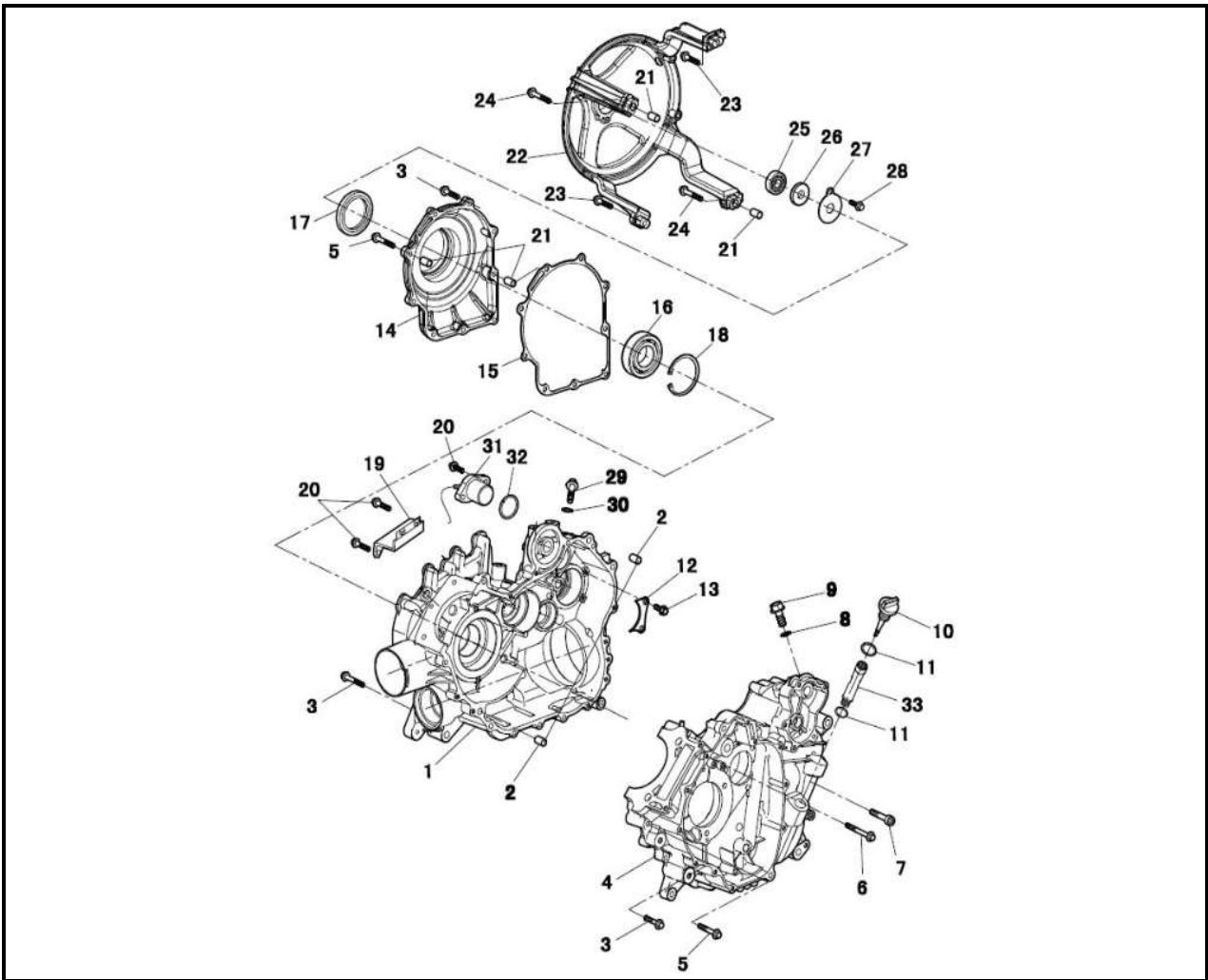

No.	Part Name	Qty	Remarks
26	Oil Seal 12×32×6	1	For installation, reverse the removal procedure.
27	Press Plate, Bracket Oil Seal	1	
28	Hexagon Flange Bolts M6×16	1	
29	Hexagon Flange Bolts M10×1.25×16	1	
30	Aluminum Washer 10×16×1.2	1	
31	Sensor, Gear Shift Indicator	1	
32	O-Ring 29.6×2.4	1	
33	Guiding Tube, Oil Level	1	

# ENGINE

## Crankcase bearings

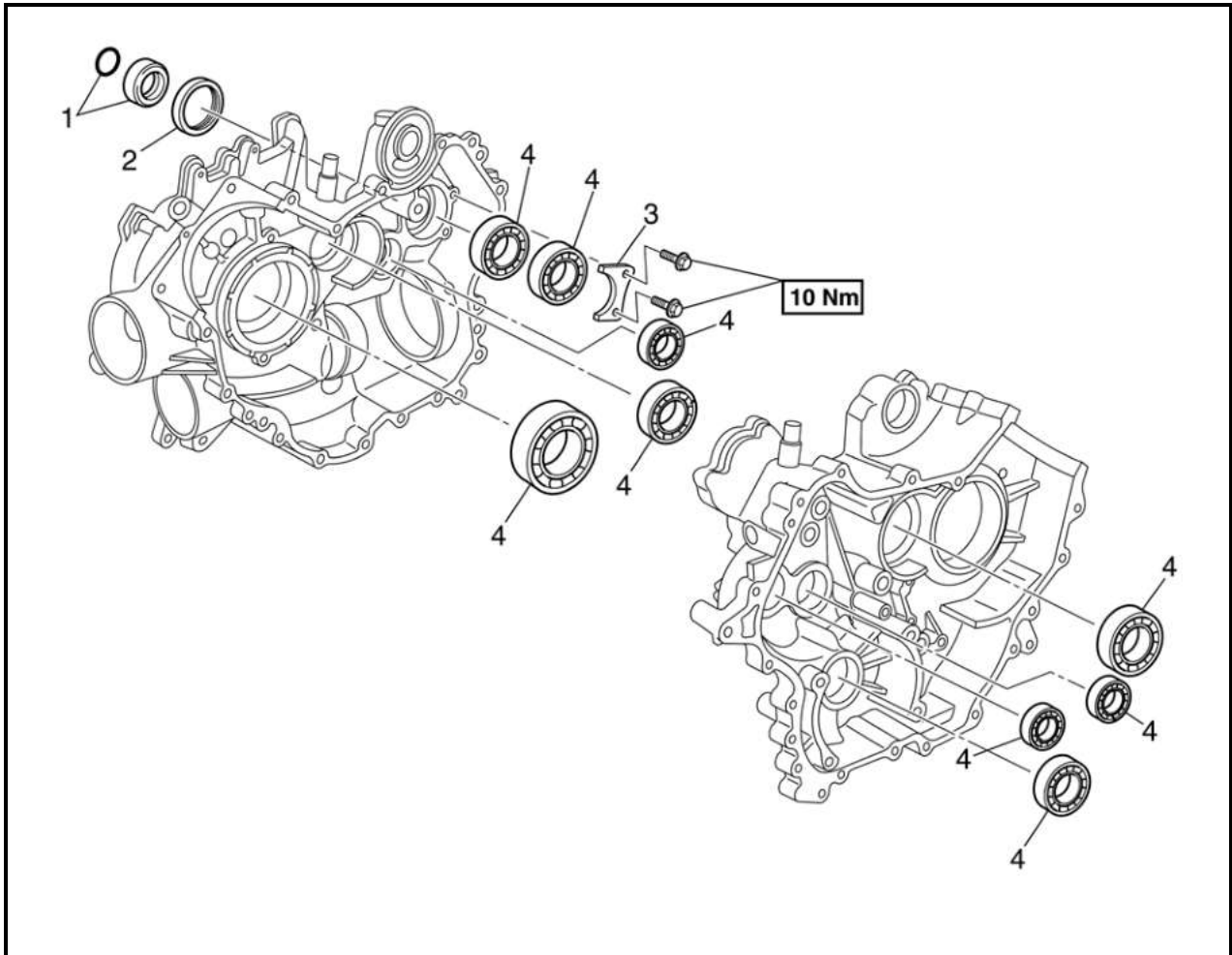

No.	Part Name	Qty	Remarks
	<b>Removing the crankcase bearings</b>		Remove the parts in the order listed.
	Crankshaft and oil pump		
	Transmission		
	Middle drive/driven shaft		
1	O-ring/collar	1/1	
2	Oil seal	1	
3	Bearing retainer	1	
4	Bearing	9	
			For installation, reverse the removal procedure.

## ENGINE

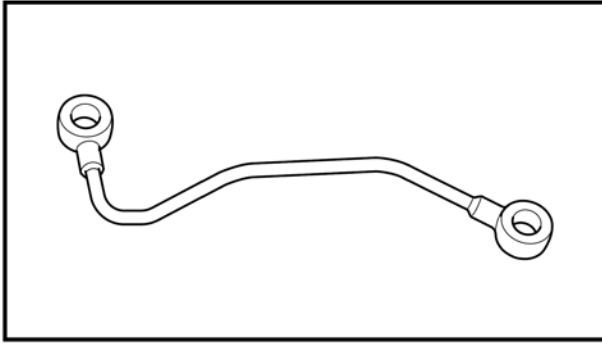

### 1. CHECK

- 1). Checking the oil delivery pipe
  - oil delivery pipe
  - Cracks/damage → Replace.
  - Clogged → Blow out with compressed air.

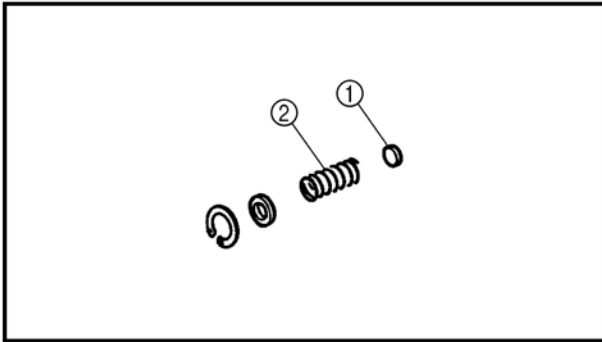

### 2). Checking the relief valve

- relief valve ①
- spring ②
- Damage/wear → Replace the defective part(s).

### 3). Checking the crankcase

- (1) Thoroughly wash the case halves in a mild solvent.
- (2) Clean all the gasket mating surfaces and crankcase mating surfaces thoroughly
- (3) heck:
  - crankcase
  - Cracks/damage → Replace.
  - oil delivery passages
  - Clogged → Blow out with compressed air.

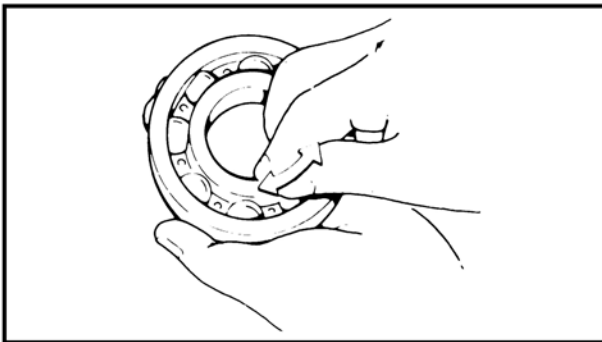

### 4). Checking the bearings

- (1) Check:
  - bearings
  - Clean and lubricate, then rotate the inner race with a finger.
  - Roughness → Replace

# ENGINE

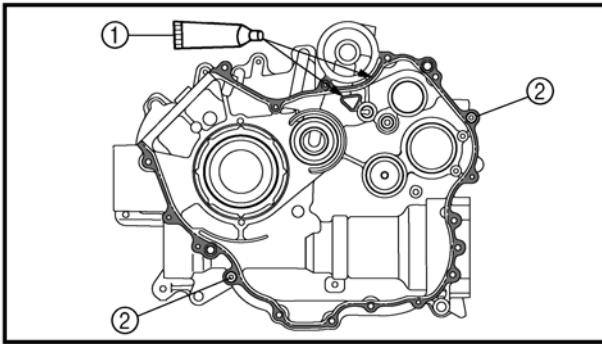

## 2. INSTALL

### 1). Assembling the crankcase

#### (1) Apply:

- sealant (Quick Gasket) ①  
(to the mating surfaces of both case halves)

#### (2) Install:

- dowel pins ②

#### (3) Fit the left crankcase onto the right case. Tap lightly on the case with a soft hammer

### **CAUTION:**

**Before installing and torque the crankcase holding bolts, be sure to check whether the transmission is functioning properly by manually rotating the shift drum in both directions.**

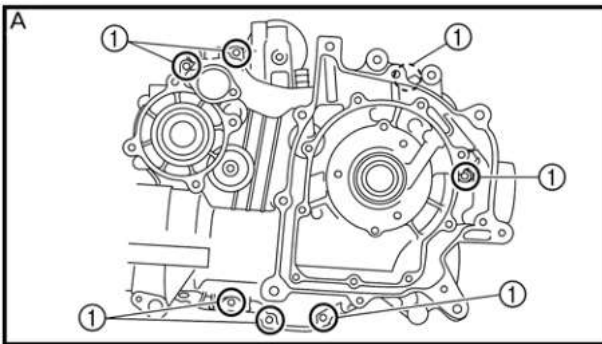

#### (4) Tighten:

- crankcase bolts ①, ② (10Nm)  
(follow the proper tightening sequence)
- crankcase bolts ③ (26Nm)  
(follow the proper tightening sequence)

A Left crankcase

B Right crankcase

### **NOTE:**

- Tighten the bolts in stages, using a criss cross pattern.
- Apply sealant (Quick Gasket) ④ to the thread of the bolt ② shown in the illustration

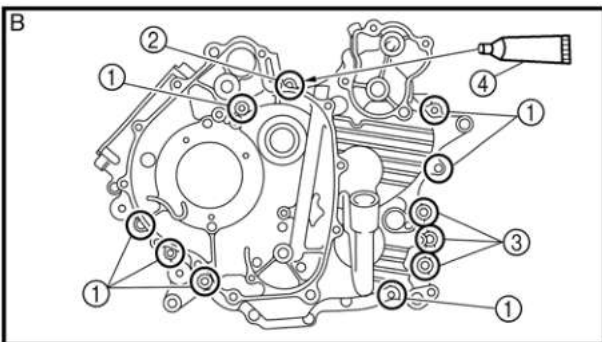

#### (5) Apply:

- 4-stroke engine oil  
(to the crank pin, bearing and oil delivery hole)

## ENGINE

---

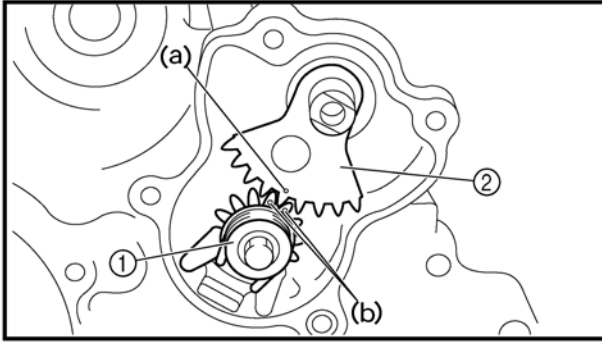

### 2). Installing the shift levers

- shift lever 2 assembly ① (14Nm)
- shift lever 1 ②

---

**NOTE:**

When installing the shift lever 1, align the punch mark (a) on the shift lever 1 with the punch marks (b) on the shift lever 2.

---



# ENGINE

## CRANKSHAFT AND OIL PUMP

### Crankshaft and oil pump

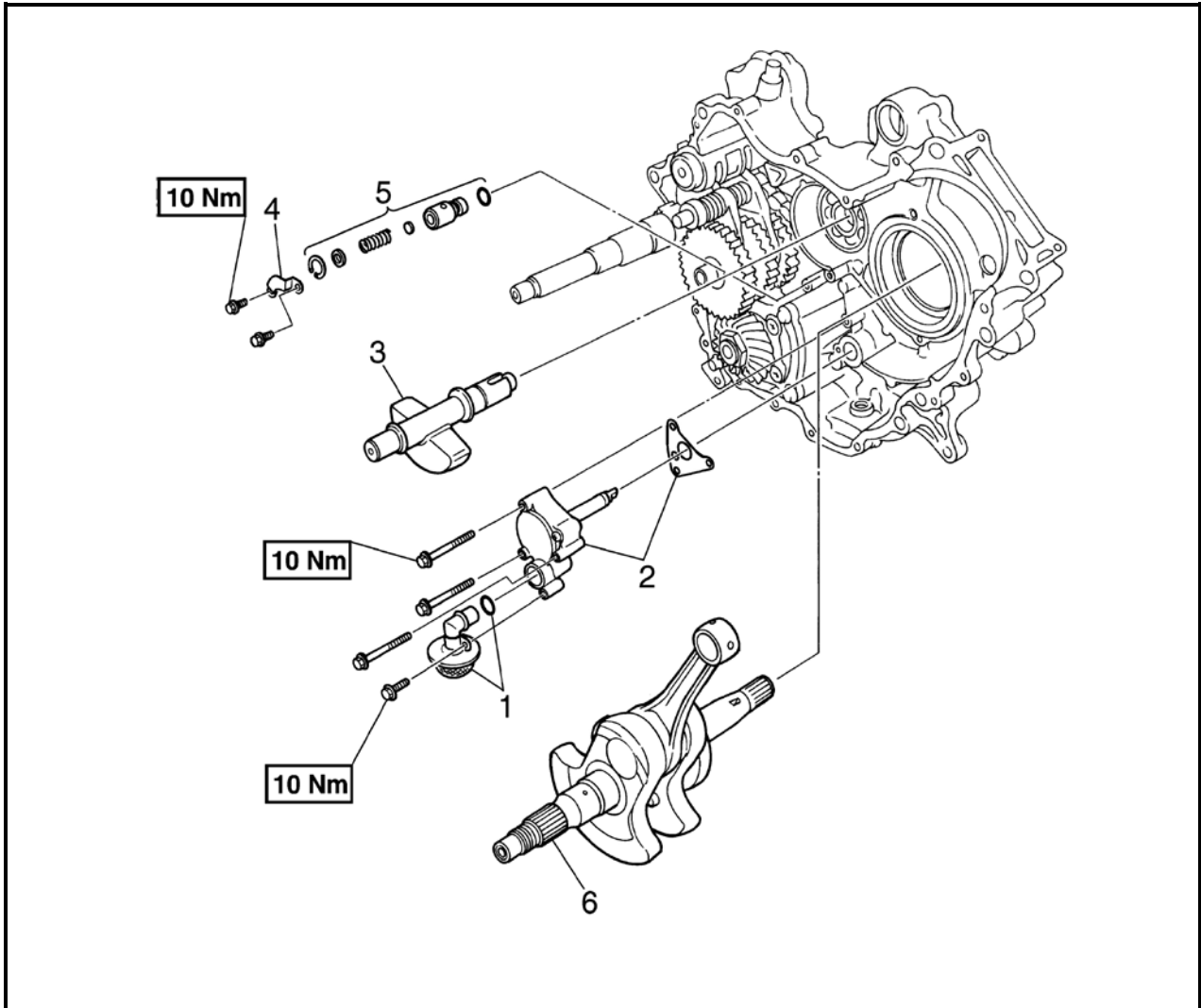

No.	Part Name	Qty	Remarks
	<b>Removing the crankshaft and oil pump</b>		Remove the parts in the order listed.  For installation, reverse the removal procedure.
	Crankcase separation		
1	Oil strainer/O-ring	1/1	
2	Oil pump assembly/gasket	1/1	
3	Balancer	1	
4	Plate	1	
5	Relief valve assembly	1	
6	Crankshaft	1	

# ENGINE

## Oil pump

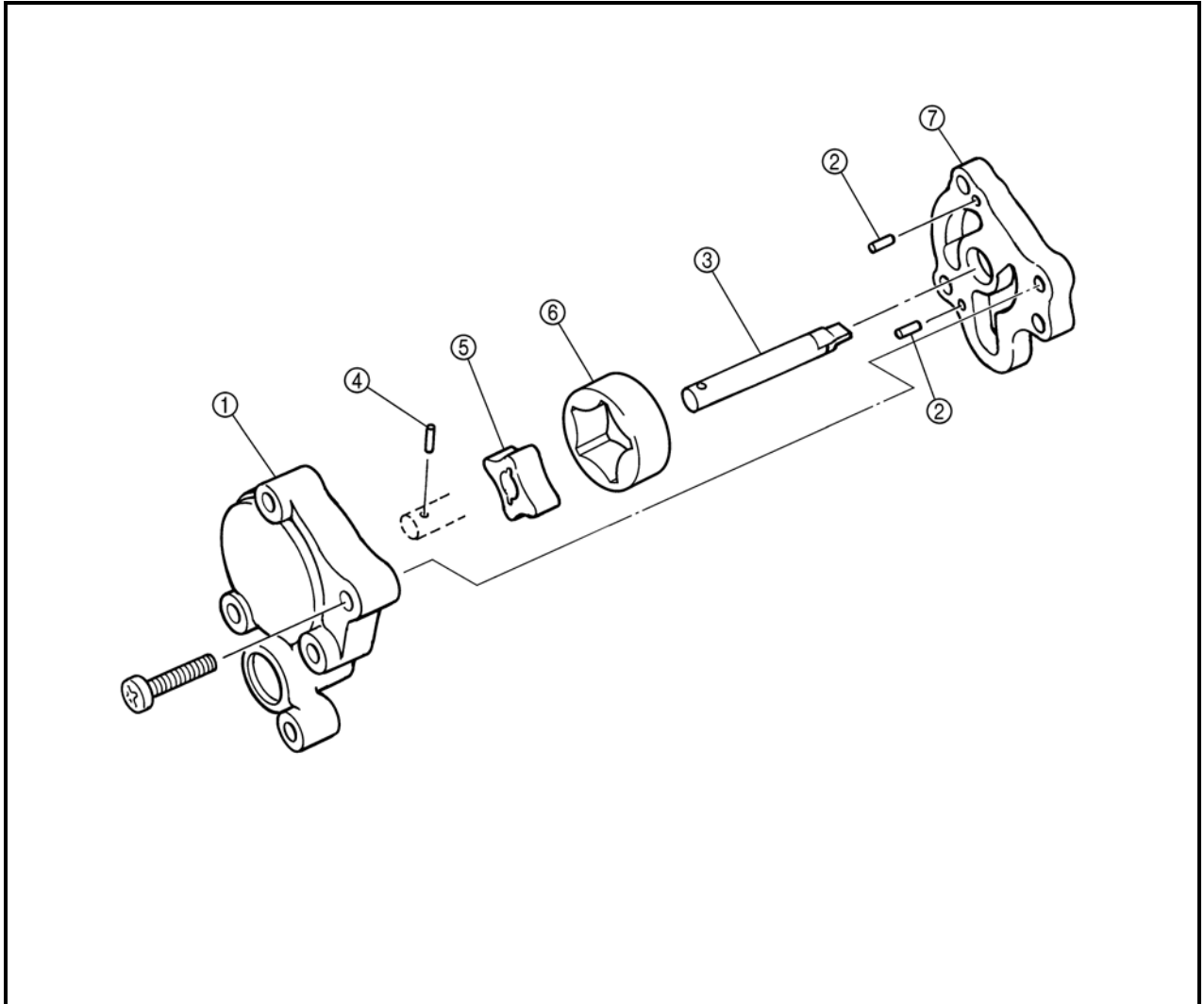

No.	Part Name	Qty	Remarks
	<b>Disassembling the oil pump</b>		Remove the parts in the order listed.
①	Rotor cover	1	
②	Pin	2	
③	Shaft	1	
④	Pin	1	
⑤	Inner rotor	1	
⑥	Outer rotor	1	
⑦	Oil pump housing	1	
			For assembly, reverse the disassembly procedure.

# ENGINE

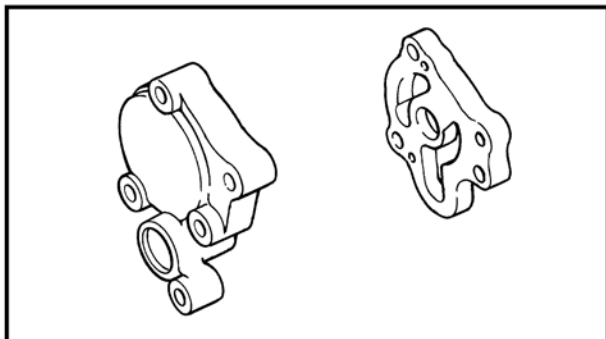

## 1、 CHECK

### 1). Checking the oil pump

- rotor housing
- rotor cover
- Cracks/wear/damage → Replace.
- oil pump operation
- Unsmooth → Repeat steps #1 and #2 or replace the defective parts.

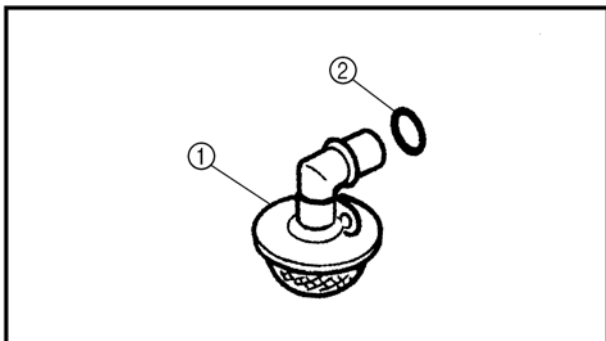

### 2). Checking the oil strainer

- oil strainer ①
- O-ring ②
- Damage → Replace.
- Contaminants → Clean with engine oil.

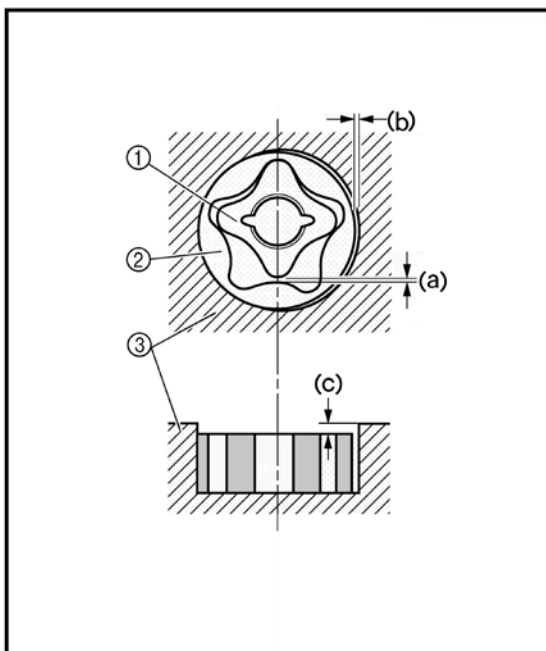

## 2、 MEASURE

### 1). Measure the oil pump

- tip clearance(a)
- (between the inner rotor ① and the out rotor ②)
- side clearance(b)
- (between the outer rotor ② and the pump housing ③)
- body clearance (c)
- (between the outer rotor ② and the pump housing ③)
- Out of specification → Replace the oil pump.

**Tip clearance Limit: 0.23 mm**  
**Side clearance Limit: 0.17 mm**  
**Body clearance Limit: 0.24 mm**

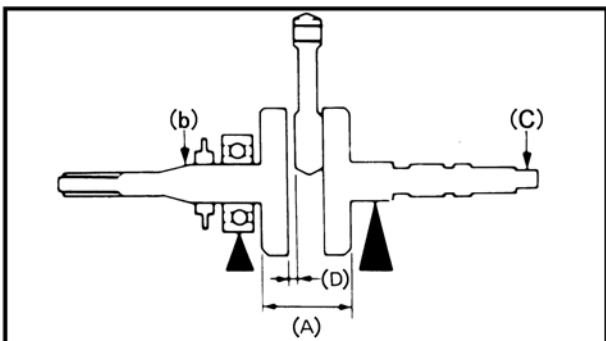

### 2). Measure the crankshaft

- crank width (A)
- Out of specification → Replace the crankshaft.

**Crank width**  
**74.95 ~ 75.00 mm**

- side clearance (D)
- Out of specification → Replace the crankshaft

## ENGINE

### Big end side clearance

Limit: 1.0 mm (0.0394 in)

- runout (b)(C)

Out of specification → Replace the crankshaft.

### Runout limit

(b): 0.03 mm (C): 0.03 mm

The crankshaft ① and the crank pin ② oil passages must be properly interconnected with a tolerance of less than 1 mm (0.04 in).

### CAUTION:

The buffer boss and woodruff key should be replaced when removed from the crankshaft.

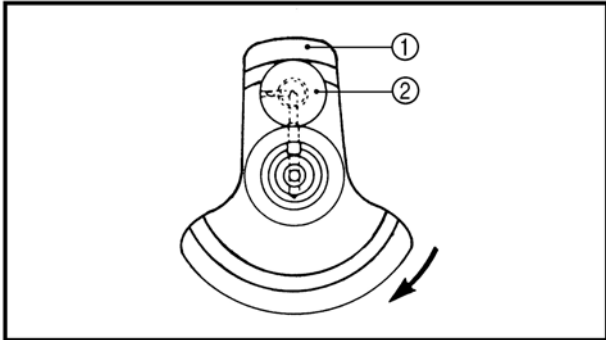

### 3. INSTALL

- 1). Assembling the oil pump

- inner rotor
- outer rotor
- oil pump shaft

(with the recommended lubricant)

- 2). Installing the crankshaft and balancer

- crankshaft

### NOTE:

Hold the connecting rod at the Top Dead Center (TDC) with one hand while turning the nut of the installing tool with the other. Operate the installing tool until the crankshaft bottoms against the bearing.

# ENGINE

## TRANSMISSION

### Transmission

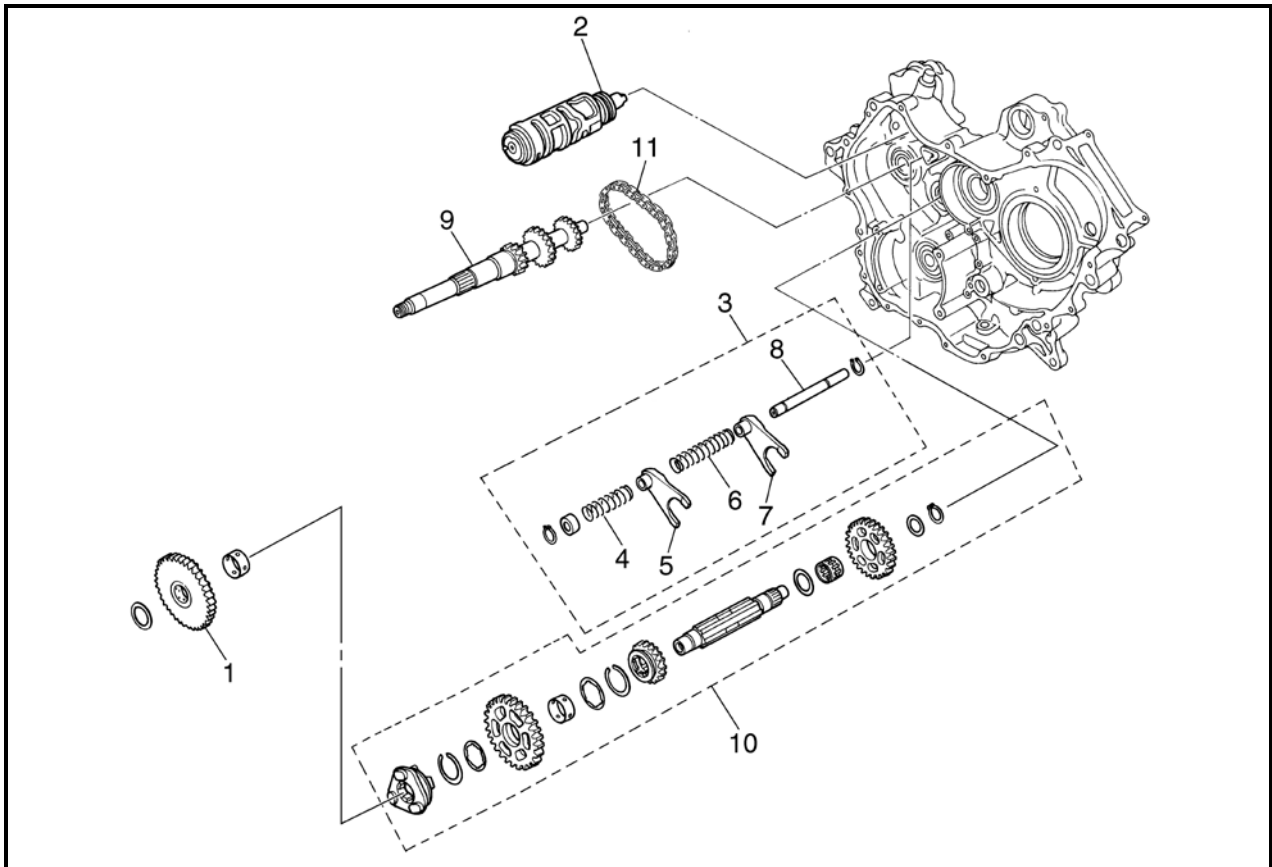

No.	Part Name	Qty	Remarks
	<b>Removing the transmission</b>		Remove the parts in the order listed.  For installation, reverse the removal procedure.
	Crankcase separation		
	Middle driven gear		
1	Low wheel gear	1	
2	Shift drum	1	
3	Shift fork assembly	1	
4	Short spring	1	
5	Shift fork 1	1	
6	Long spring	1	
7	Shift fork 2	1	
8	Guide bar	1	
9	Secondary shaft	1	
10	Drive axle assembly	1	
11	Chain	1	

# ENGINE

## Drive axle assembly

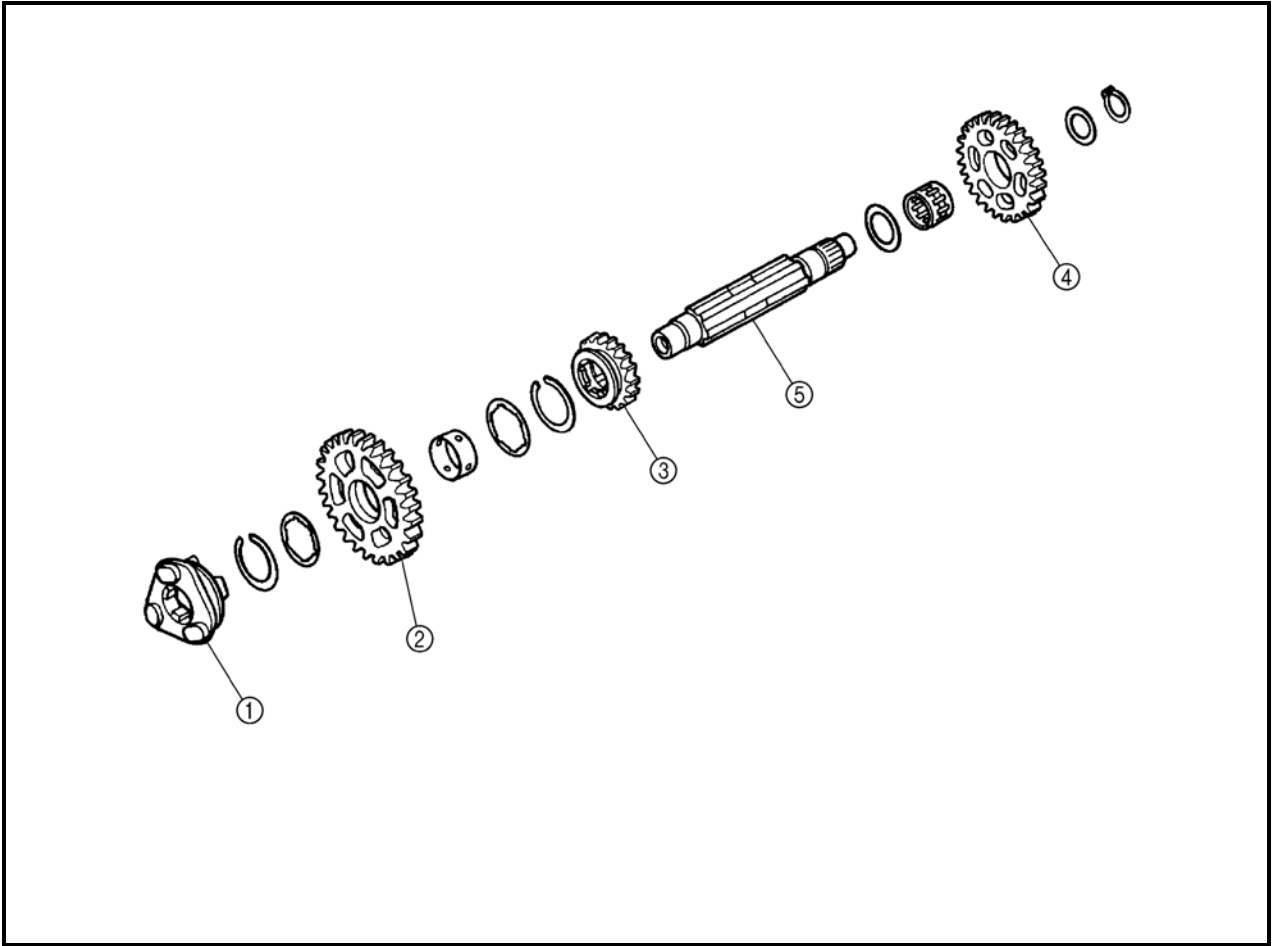

No.	Part Name	Qty	Remarks
	<b>Disassembling the drive axle</b>		
①	Clutch dog	1	Remove the parts in the order listed.
②	High wheel gear	1	
③	Middle drive gear	1	
④	Driven sprocket	1	
⑤	Drive axle	1	
			For assembly, reverse the disassembly procedure.

## ENGINE

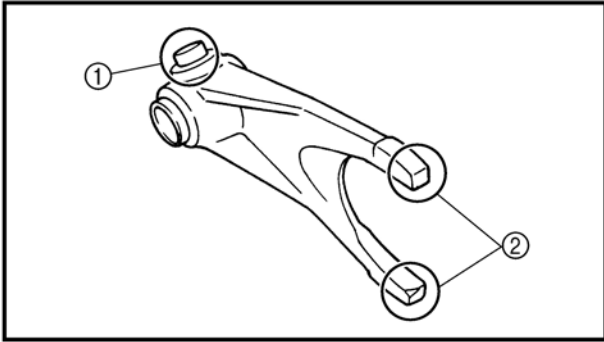

### 1. CHECK

#### 1). Checking the shift forks

- shift fork follower ①
  - shift fork pawl ②
- Scoring/bends/wear/damage → Replace.
- guide bar
- Roll the guide bar on a flat surface.
- Bends → Replace.

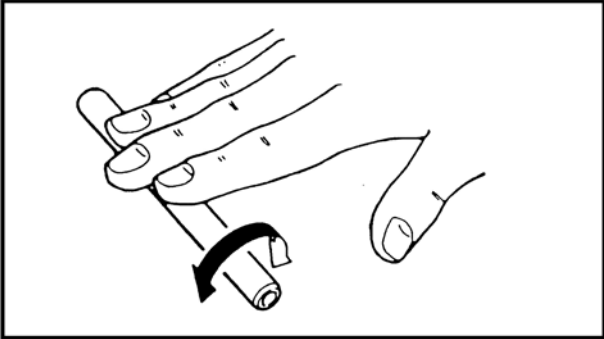

### **WARNING:**

***Do not attempt to straighten a bent guide bar.***

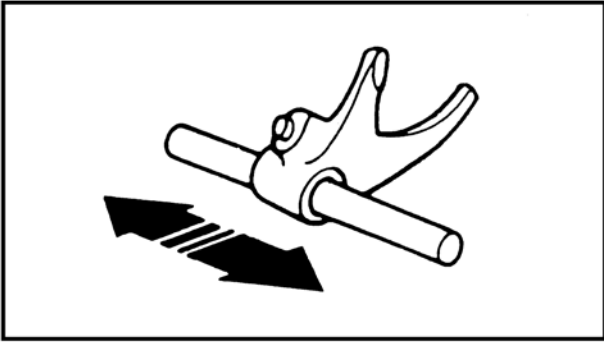

- shift fork movement  
(on the guide bar)
- Unsmooth operation → Replace the shift fork and the guide bar.

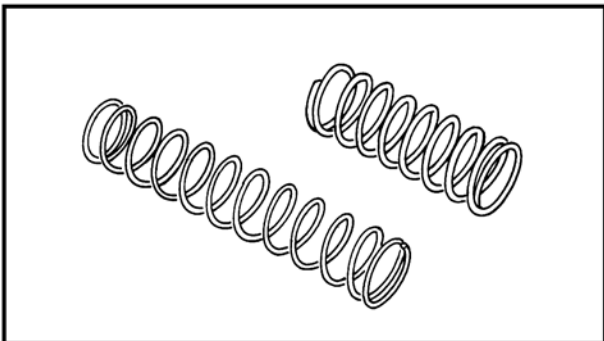

- springs
- Cracks/damage → Replace.

#### 2). Checking the shift drum

- shift drum grooves
- Scratches/wear/damage → Replace.

## ENGINE

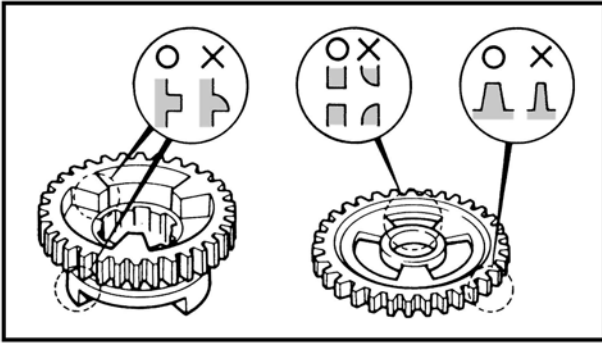

### 3). Checking the high wheel gear and middle drive gear

- gear teeth  
Blue discoloration/pitting/wear → Replace.
- mated dogs  
Rounded edges/cracks/missing portions  
→ Replace.
- gear movement  
Unsmooth → Repeat steps #1 or replace the defective parts.

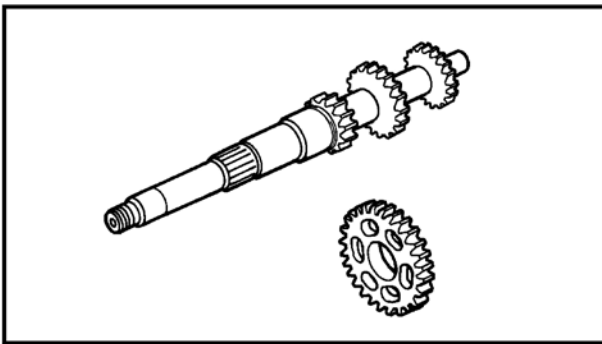

### 4). Checking the secondary shaft and driven sprocket

- gear teeth  
Blue discoloration/pitting/wear → Replace.
- gear movement  
Unsmooth → Repeat steps #1 or replace the defective parts.

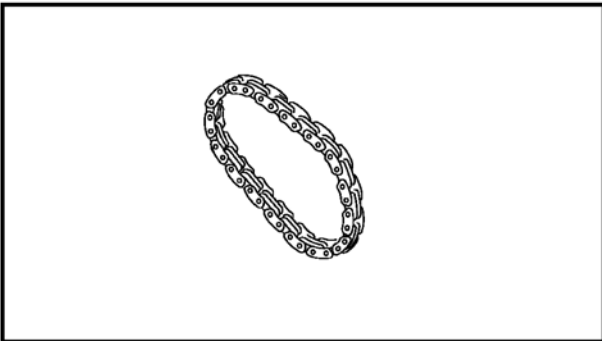

- circlip  
Bends/looseness/damage → Replace.

### 5). Checking the chain

- chain  
Cracks/shift → Replace the chain, secondary shaft and driven sprocket as a set.

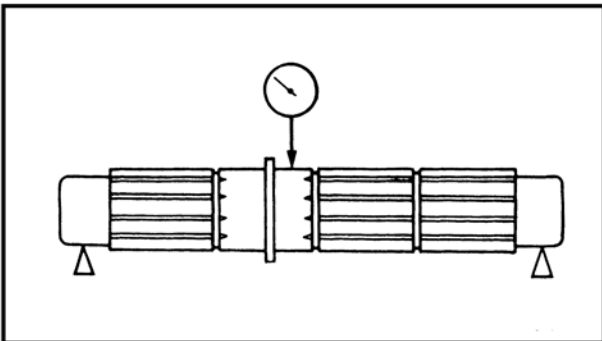

### 2. Measure:

- axle runout  
Use a centering device and a dial gauge.  
Out of specification → Replace the bent axle.

**Drive axle runout limit**

**0.06 mm**



## ENGINE

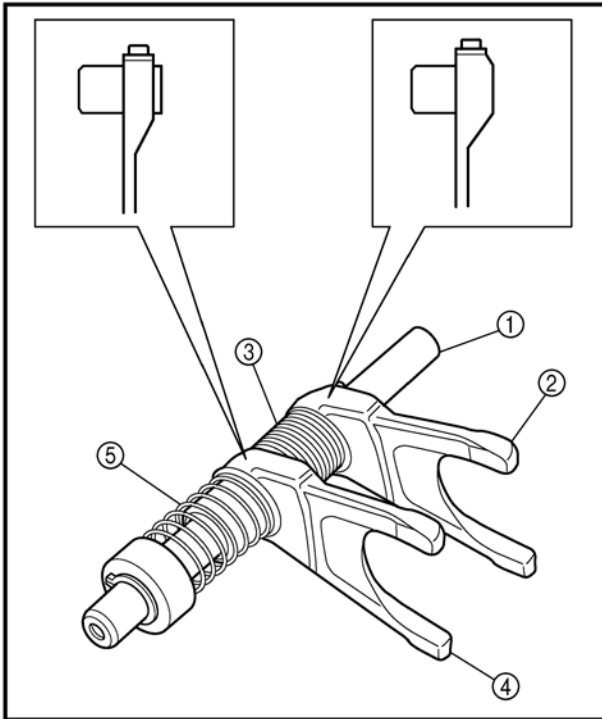

### 3. INSTALL

#### 1). Assembling the shift fork

- guide bar ①
- shift fork 2 ②
- long spring ③
- shift fork 1 ④
- short spring ⑤

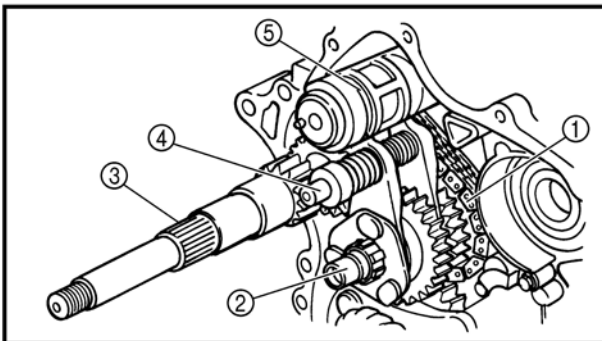

#### 2). Installing the transmission

- chain ①
- drive axle assembly ②
- secondary shaft ③
- shift fork assembly ④
- shift drum ⑤
- low wheel gear

#### **NOTE:**

- Oil each gear and bearing thoroughly.
- Before assembling the crankcase, be sure that the transmission is in neutral and that the gears turn freely.

# ENGINE

## MIDDLE GEAR

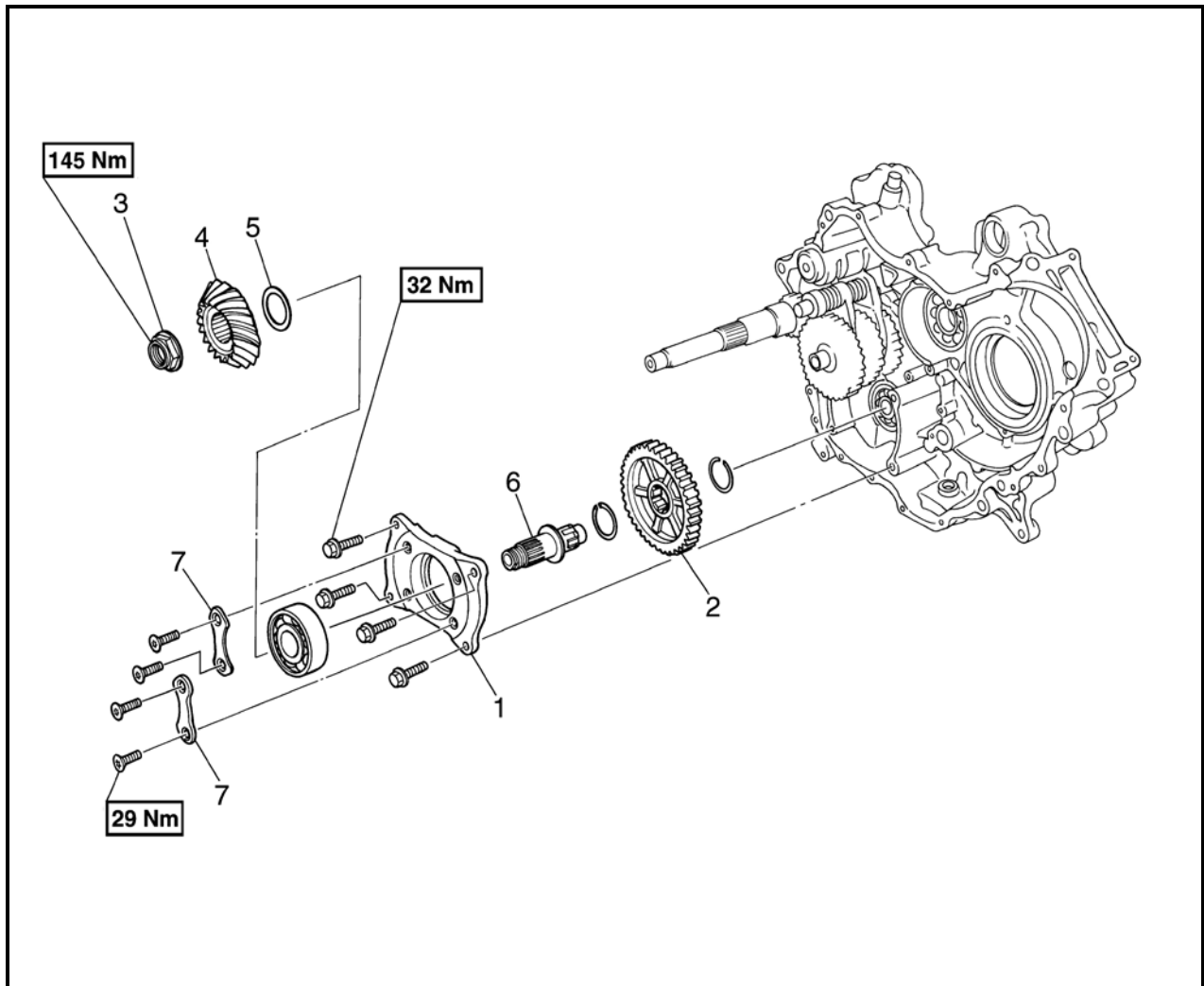

No.	Part Name	Qty	Remarks
	<b>Removing the middle drive shaft</b>		Remove the parts in the order listed.
	Crankcase separation		
1	Bearing housing	1	
2	Middle drive gear	1	
3	Nut	1	
4	Middle drive pinion gear	1	
5	Shim	1	
6	Middle drive shaft	1	
7	Bearing retainer	2	
			For assembly, reverse the disassembly procedure.

# ENGINE

## Middle driven shaft

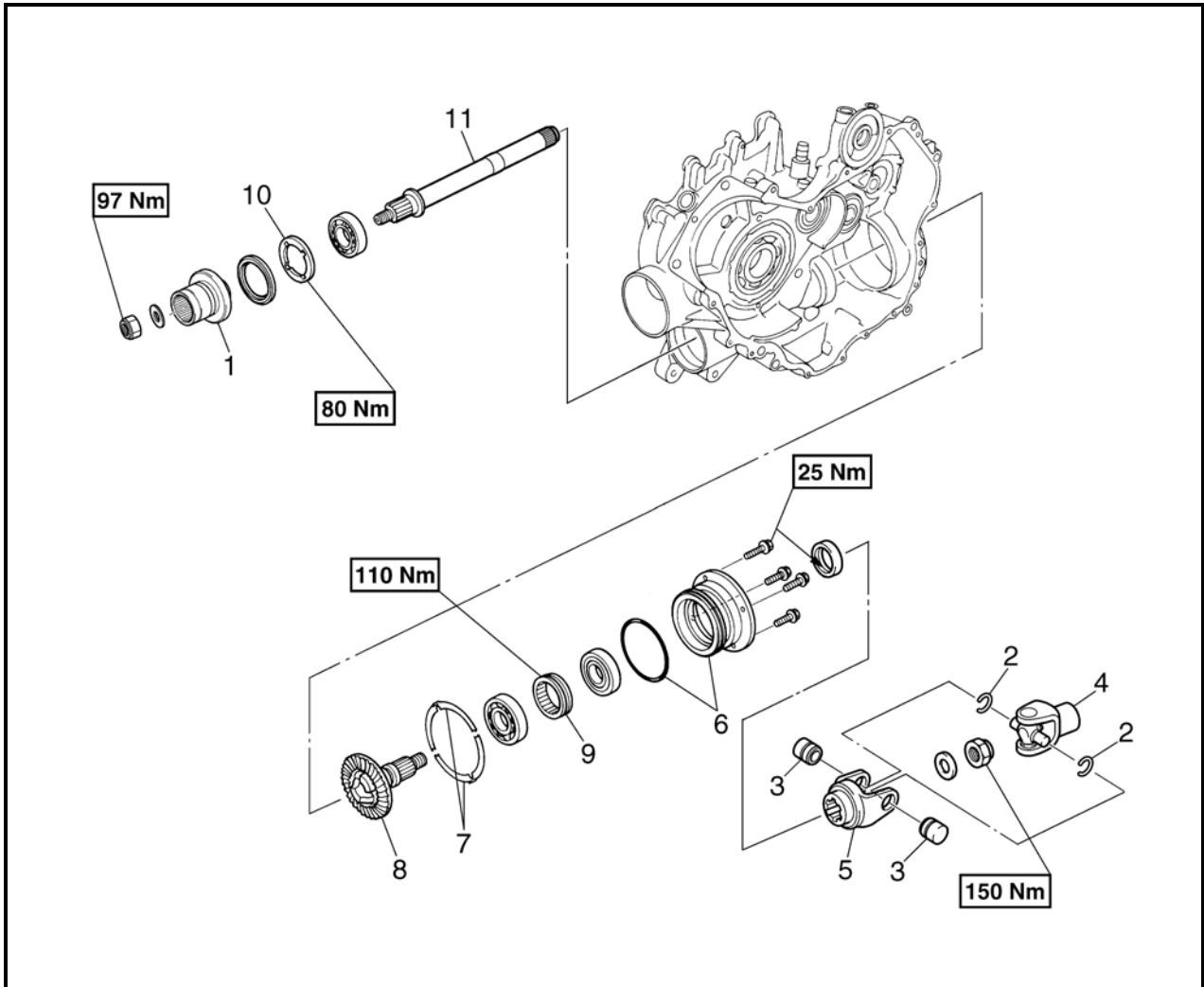

No.	Part Name	Qty	Remarks
	<b>Removing the middle drive shaft</b>		Remove the parts in the order listed.
	Crankcase separation		
1	Drive shaft coupling	1	
2	Circlip	2	
3	Bearing	2	
4	Universal joint	1	
5	Universal joint yoke	1	
6	Bearing housing/O-ring	1/1	
7	Shim	1	
8	Middle driven pinion gear	1	
9	Bearing retainer	1	
10	Bearing retainer	1	

# ENGINE

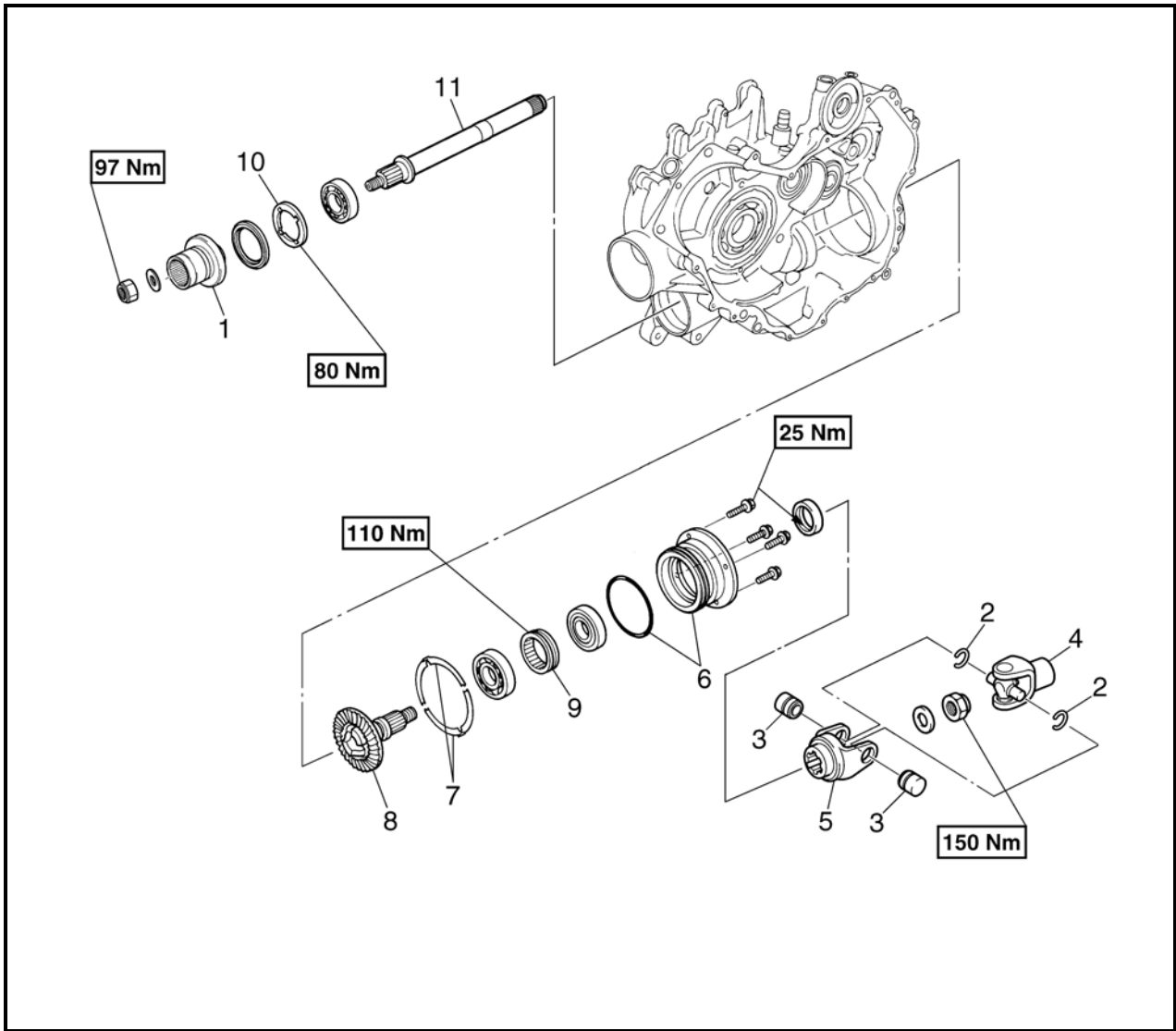

No.	Part Name	Qty	Remarks
11	Middle driven shaft	1	For installation, reverse the removal procedure.

# ENGINE

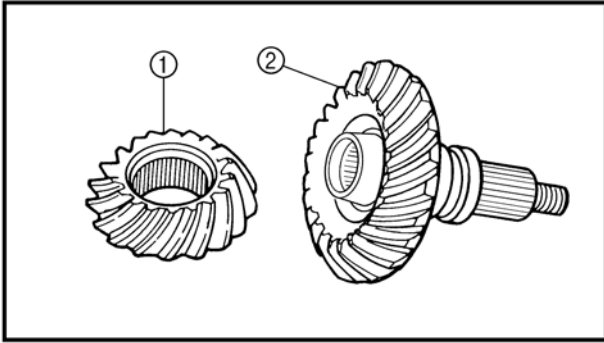

## 1、 CHECK

- 1). Checking the pinion gears
  - gear teeth (drive pinion gear) ①
  - gear teeth (driven pinion gear) ②
  - Pitting/galling/wear → Replace.
  - O-ring
  - Damage → Replace.
  - bearings
  - Pitting/damage → Replace.
  - universal joint movement
  - Roughness → Replace universal joint.

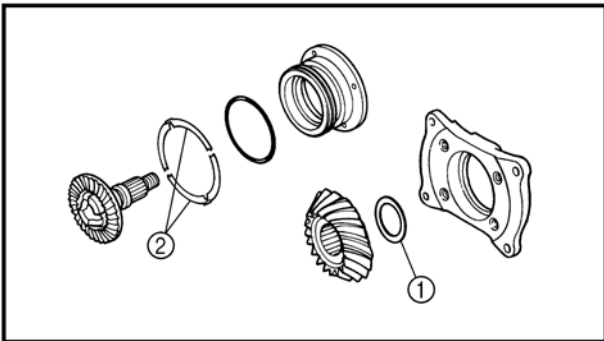

- 2). Selecting the middle drive and driven gear shims
- When the drive and driven gear, bearing housing assembly and/or crankcase replaced, be sure to adjust the gear shims ① and ②.
- middle drive gear shim ①
  - middle driven gear shim ②

## 2、 MEASURE

- gear lash

**Middle gear lash**  
**0.1 ~ 0.3 mm**

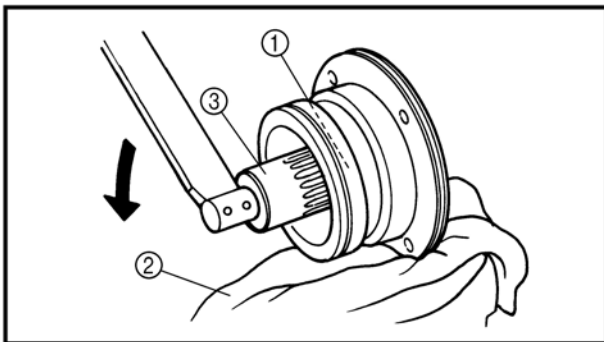

- a. Temporary install the left crankcase.
- b. Wrap a rag ① around a screwdriver ②, and then insert it into the installation hole ③ of the right crankcase speed sensor to hold the middle driven gear.
- c. Attach the gear lash measurement tool ④ and dial gauge ⑤.
  - a) 6.7 mm (0.26 in)
- d. Measure the gear lash while rotating the middle driven shaft back and forth.

### **NOTE:**

**Measure the gear lash at 4 positions. Rotate the middle driven gear 90° each time. If the gear lash is incorrect, adjust the gear lash by middle driven pinion gear shims and/or middle drive pinion gear shim(s).**

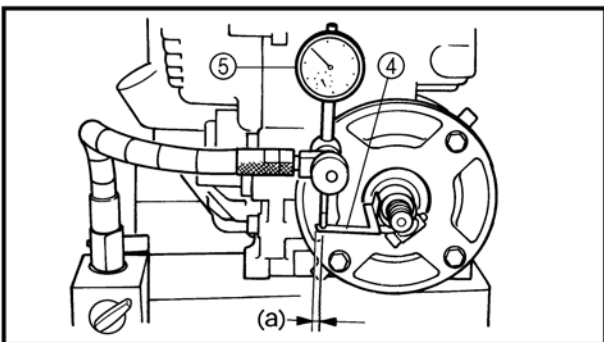

# ENGINE

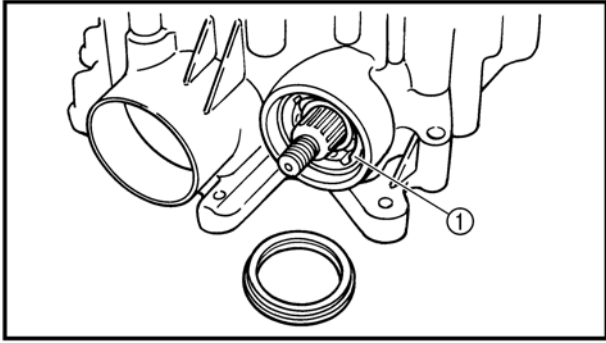

## 3、INSTALL

- 1). Installing the middle driven shaft
  - bearing retainer ①

**Bearing retainer**  
80 Nm

**NOTE:**

Attach the ring nut wrench ②.

**CAUTION:**

The middle driven shaft bearing retainer has left-handed threads. To tighten the retainer, turn it counterclockwise.

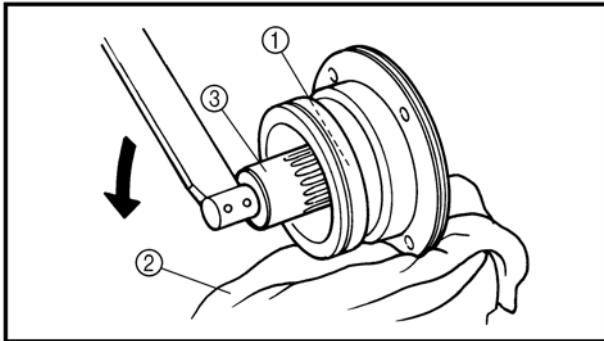
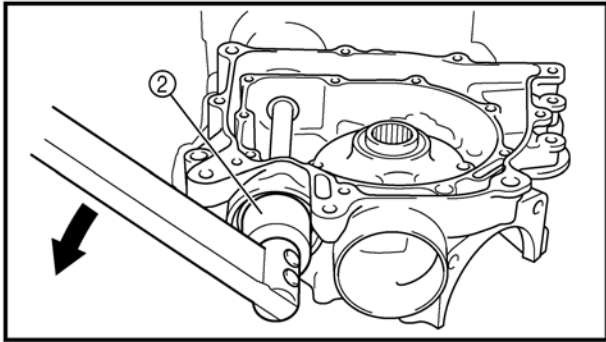

- bearing retainer ①

- a. Place a rag ② in the vise.
- b. Secure the bearing housing edge in the vise.
- c. Attach the bearing retainer wrench ③.
- d. Tighten the bearing retainer.

**CAUTION:**

The middle driven shaft bearing retainer has left-handed threads. To tighten the retainer, turn it counterclockwise.

**Bearing retainer**  
110Nm

- shims ①
- bearing housing

**NOTE:**

Install the shims so that the tabs are positioned as shown in the illustration.

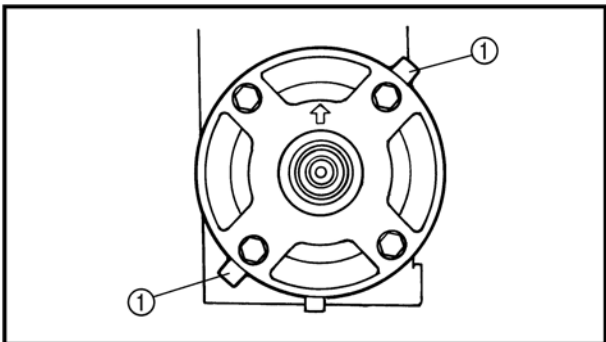

## ENGINE

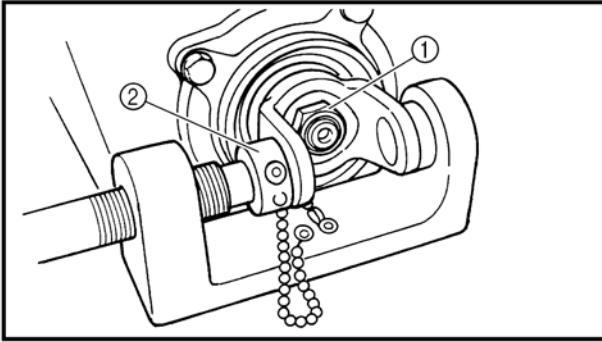

- universal joint yoke
- washer
- nut ①

### NOTE:

Use the universal joint holder ② to hold the yoke.

### Universal joint yoke nut

150 Nm

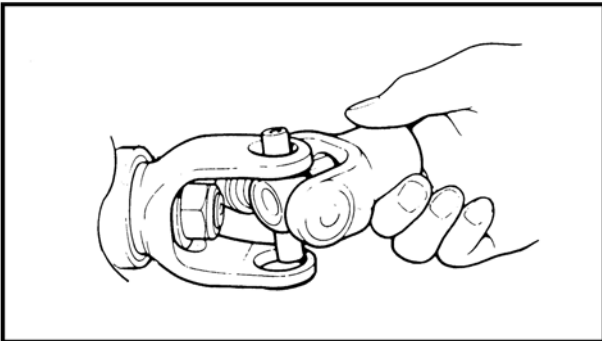

- universal joint.
- Install the opposite yoke into the universal joint.
  - Apply wheel bearing grease to the bearings.

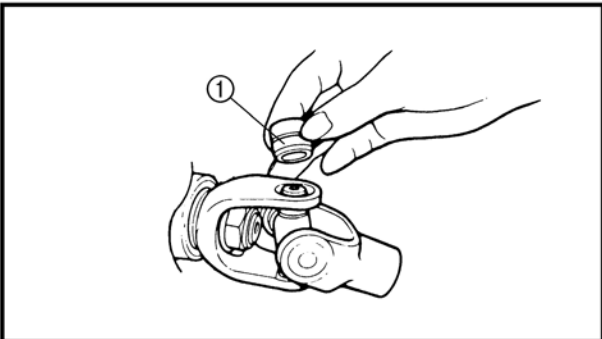

- Install the bearing ① onto the yoke.

### CAUTION:

Check each bearing. The needles can easily fall out of their races. Slide the yoke back and forth on the bearings; the yoke will not go all the way onto a bearing if a needle is out of place.

- Press each bearing into the universal joint using a suitable socket.

### NOTE:

The bearing must be inserted far enough into the universal joint so that the circlip can be installed.

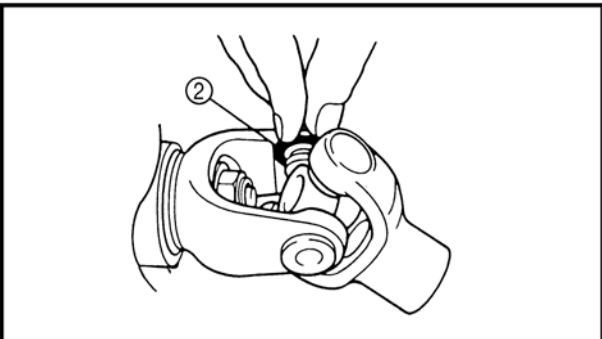

- Install the circlip ② into the groove of each bearing.

## ENGINE

---

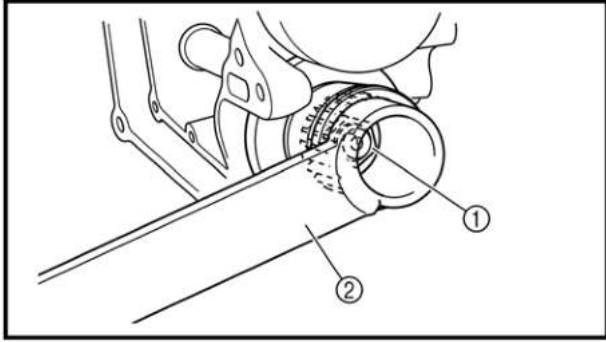

- drive shaft coupling
- washer
- nut (97Nm)

**NOTE:**

Use the coupling gear/middle shaft tool ② to hold the drive shaft coupling.

---

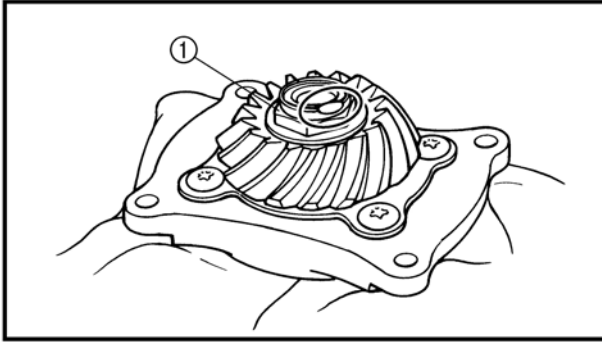

2). Installing the middle drive shaft

(1) Tighten:

- middle drive pinion gear nut ① (145Nm)

**NOTE:**

Secure the middle drive shaft in the vise with a clean rag.

---

(2) Lock the threads with a drift punch.



## CHASSIS

### MALFUNCTION INSPECTION

<b>Appearance malfunction inspection</b>		
No.	Phenomenon	Measure
1	Plastic cover damaged	1. Replace new plastic cover.
		2. Check whether installation supporter deformed, repairing or re-painting is needed before replacing new plastic cover.
		3. Re-paste decals and re-rivet warning labels.
2	Bumper damaged	1. Replace new bumper.
		2. Check whether installation supporter deformed or damaged, repairing or re-painting is needed before replacing new bumper.
3	Frame toe-board damaged	1. Replace new frame toe-board.
		2. Check whether gearbox and differential of front and rear axle damaged or leakage.
		3. Check plastic cover whether deformed or damaged, repairing deformed or damaged plastic cover.
4	Warning labels	Replace damaged and vague warning labels
<b>Brake system malfunction inspection</b>		
No.	Phenomenon	Measure
1	Locked braking system	1. Check whether brake disc plates deformed.
		2. Check whether hydraulic cylinder of brake clamp locked or brake clamp assembly parts deformed.
2	Brake performance degressive	1. Check whether disc plates abrasion exceeded limits.
		2. Check whether brake shoe of clamp abrasion exceeded limits or polluted by friction material such as oil.
		3. Check whether the oil cup of brake fluid lack oil.
3	Grinding noises emerged from front brake or brake plate become red during drive due to superheat.	1. Check whether brake plate deformed.
		2. Check whether hydraulic cylinder of brake clamp locked or brake clamp assembly parts deformed.
4	Grinding noises emerged from rear brake or brake plate become red during drive	1. Check whether brake plate deformed.
		2. Check whether hydraulic cylinder of brake clamp locked or brake clamp assembly parts deformed.
		3. Check whether rear brake clamp parking institution running flexible or return accurately.
5	Off tracking by braking at high-speed	1. Check whether front brake power deviation from left and right is within specified scope.
		2. Check whether front brake power degressive caused to rear wheel locked before front wheel in brake process.
		3. Check whether left and right absorber spring force deviation is exceeded specified value.

## CHASSIS

5	Off tracking by braking at high-speed	4. Check whether front wheel and front wheel axle nut loosen or damaged.
		5. Check whether front wheel hub inner spline and front wheel axle outer spline worn or loosen.
		6. Check whether rubber cushion connected to front suspension rocker and frame damaged.
<b>Other system malfunction inspection</b>		
No.	Phenomenon	Measure
1	Steering wheel loosen, shift up and down	1. Check whether steering wheel clip loosen or damaged.
		2. Check whether steering column clip and clip seat loosen or damaged.
		3. Check whether steering column bottom end inner bearing damaged.
2	Front wheel steering clearance excessive	1. Check whether tie-rod and steering column locknut loosen or damaged, or steering knuckle and steering column locknut loosen or damaged.
		2. Check whether tie-rod two ball joint damaged.
3	Front wheel sway during drive	1. Check whether steering knuckle bearing damaged.
		2. Check whether king pin ball joint damaged.
		3. Check whether front wheel and axle locknut loosen or damaged.
		4. Check whether front wheel hub inner spline and front wheel axle outer spline worn or loosen.
		5. Check whether rubber cushion connected to front suspension rocker and frame damaged.
4	Rear wheel sway during drive	1. Check whether rear axle bearing damaged.
		2. Check whether sliding bearing connected to rear axle bearing housing and rocker loosen or damaged.
		3. Check whether rear wheel and axle locknut loosen or damaged.
		4. Check whether rear wheel hub inner spline and rear wheel axle outer spline worn or loosen.
		5. Check whether rubber cushion connected to rear suspension rocker and frame damaged.
5	Wheel hop during drive	1. Check whether wheel rim deformed.
		2. Check whether front and rear axles bent.
		3. Check whether tyre aging and deformed.
6	Absorber become soft and comfortability depressed	1. Check whether over loading.
		2. Check whether absorber spring become soft.
		3. Check whether absorber lost of damping force in compression and prolongation.

## CHASSIS

No.	Phenomenon	Measure
7	Front and rear axles arise abnormal sound during drive	1. Check whether front and rear axles splines damaged.
		2. Check whether gears of front gearbox and differential over worn.
		3. Check whether rear gearbox gears over worn.
		4. Check whether axle universal joint rubber boot damaged or universal joint damaged.
8	Fail to shift into four-wheel-drive or lock differential.	1. Check whether four wheel drive switch normal.
		2. Check whether power divider damaged.
		3. Check whether differential mechanical conversion agency locked or damaged.
9	Rear axle differentiation lock failure	1. Check whether the switch of rear axle differentiation lock on the dashboard is damaged .
		2. Check whether the differential mechanical conversion mechanism within the rear axle reducer is damaged.

# CHASSIS

## PANEL AND CARGO BED

### Front Panel

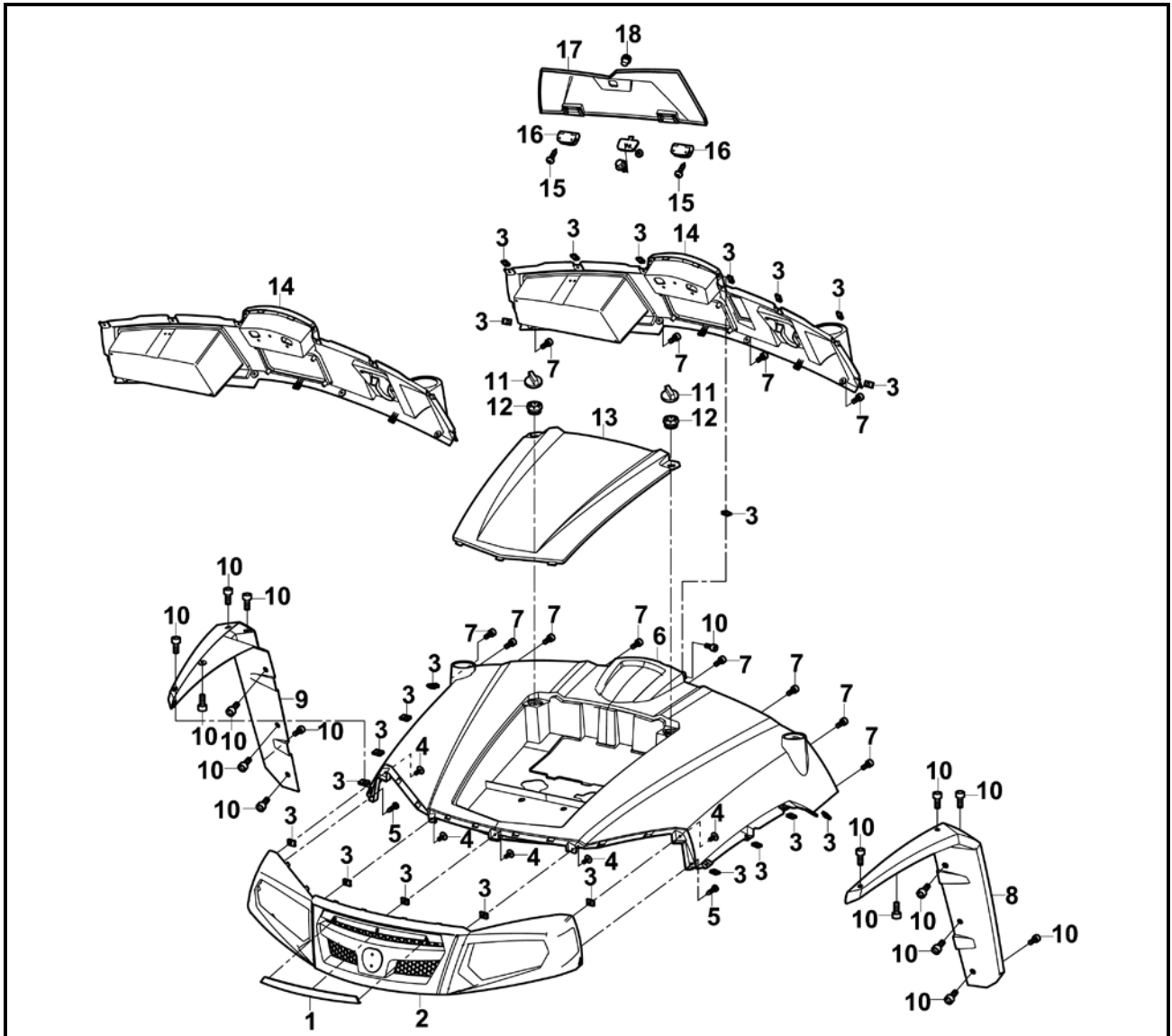

No.	Part Name	Qty	Remarks
	<b>Removing the front panel</b>		
1	Decorative plate, headlight mounting cover	1	
2	Headlight cover	1	
3	Screw thread clip M6x2	21	
4	Cross large plate head screw M6x16	5	
5	Socket hexagon plain head screws M6x16	2	
6	Front board	1	
7	Left fender, front cover	1	
8	Right fender, front cover	1	
9	Socket hexagon plain head screws M6x16	15	
10	Left fender, front cover	1	
11	Right fender, front cover	1	
12	Socket hexagon plain head screws M6x16	17	

# CHASSIS

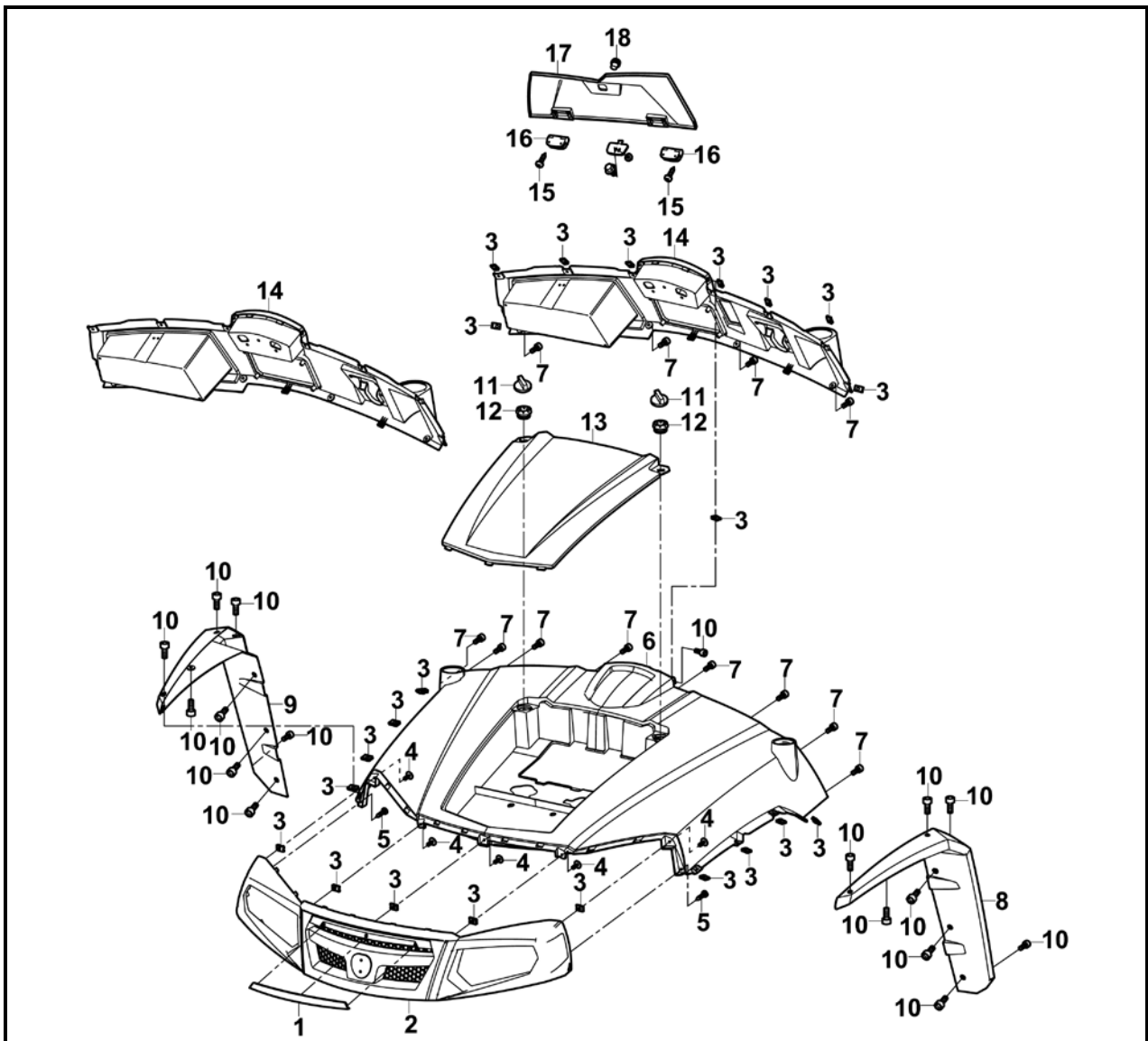

No.	Part Name	Qty	Remarks
13	Plate of front board	1	
14	Dashboard	1	
15	Dashboard	1	
16	Cross small plate head tapping screw ST4.7×13	4	
17	Plastic jaw	2	
18	Cover, glove box	1	

## CHASSIS

---

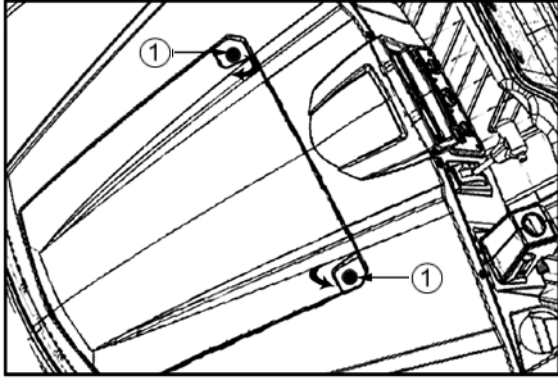

### DIASSEMBLING THE HOOD

Remove:

- Turn switch ①
- Hood cover ②

To open the hood, turn the switch as the direction in below picture to release the latch and lift the hood off. To close, tilt cover back to closed position and fasten the latches.

**CAUTION:** \_\_\_\_\_

- Never open operator's seat while the engine is running.
- \_\_\_\_\_

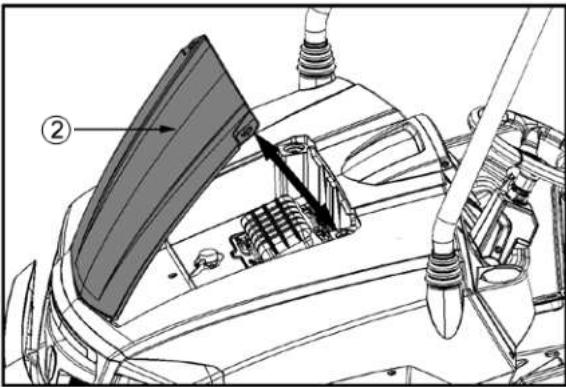

# CHASSIS

## Side Cover (Bench seat)

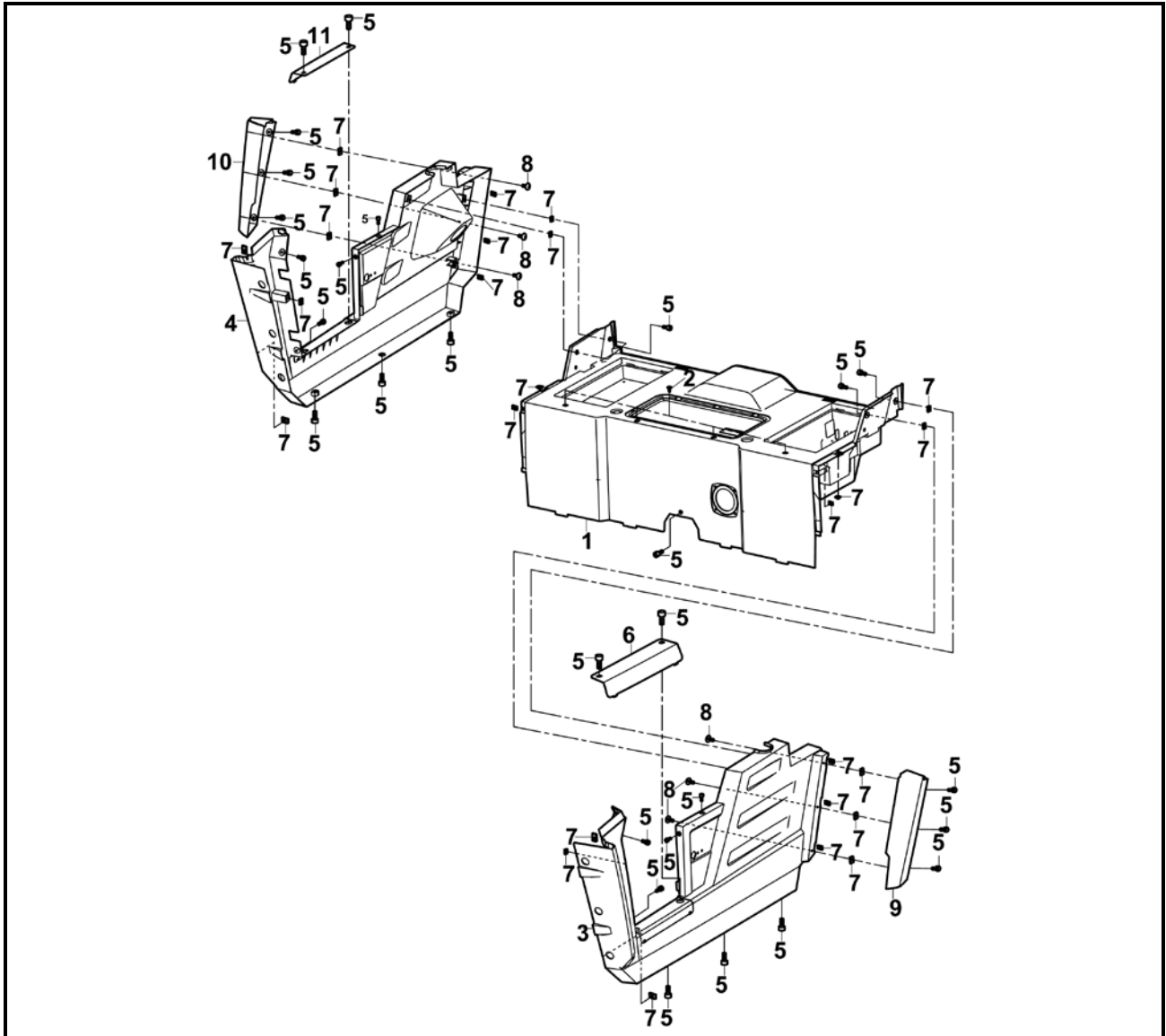

No.	Part Name	Qty	Remarks
	<b>Removing the side cover</b>		
1	Protective plate, seat cushion.	1	
2	Cross large plate head screw M6×16	4	
3	Protective plate L	1	
4	Protective plate R	1	
5	Socket hexagon plain head screws M6×16	31	
6	Side decoration plate(L)	1	
7	Screw thread clip M6×2	25	
8	Cross large plate head screw M6×16	6	
9	Rear right board, seat	1	
10	Rear left board, seat	1	
11	Decoration plate(R)	1	

# CHASSIS

## Side Cover (Bucket seat)

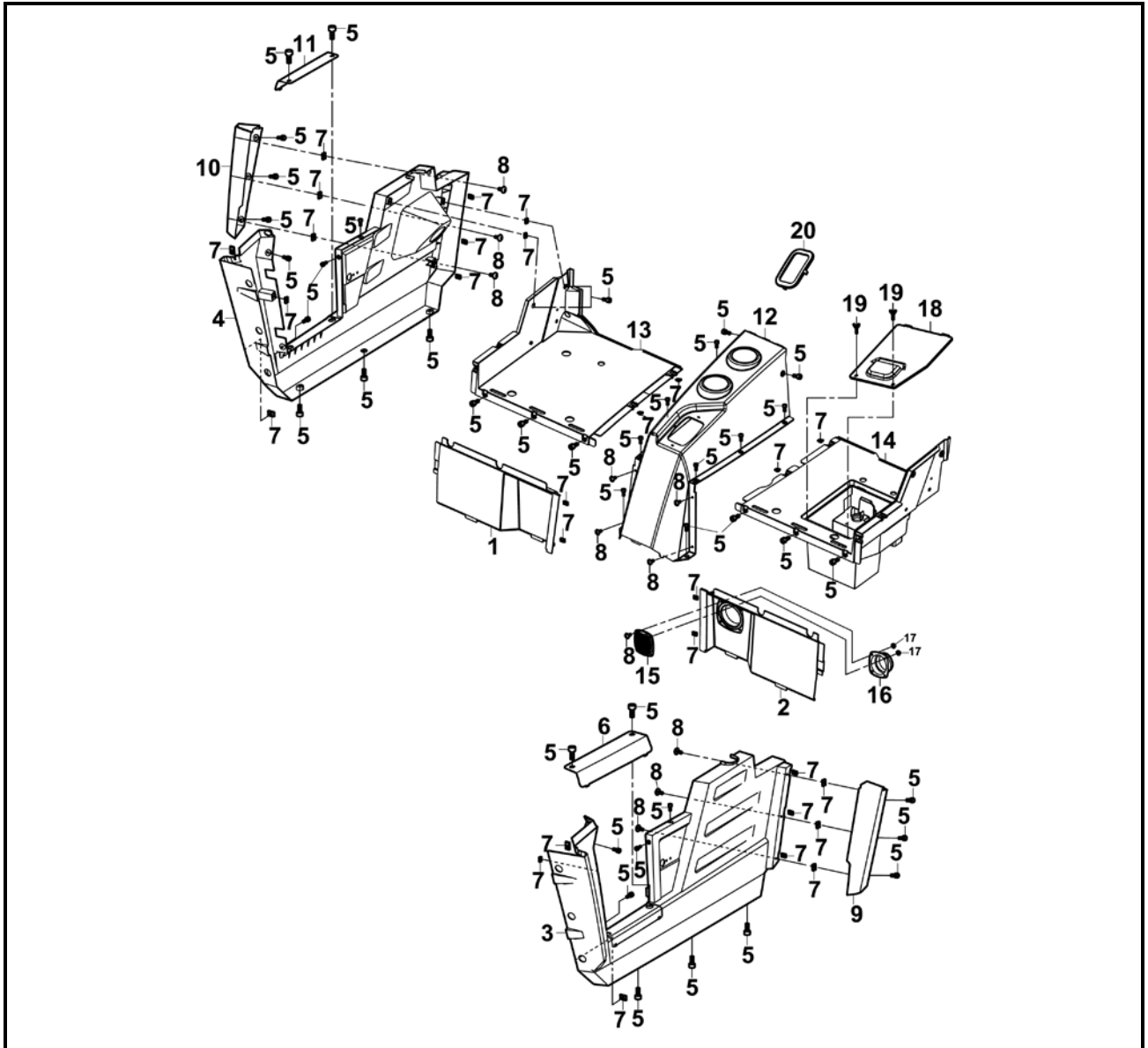

No.	Part Name	Qty	Remarks
	<b>Removing the side cover</b>		
1	Low protective plate II ,seat (R)	1	
2	Low protective plate II ,seat (L)	1	
3	Protective plate L	1	
4	Protective plate R	1	
5	Socket hexagon plain head screws M6×16	68	
6	Side decoration plate (L)	1	
7	Screw thread clip M6×2	22	
8	Cross large plate head screw M6×16	14	
9	Rear right board, seat	1	
10	Rear left board, seat	1	



# CHASSIS

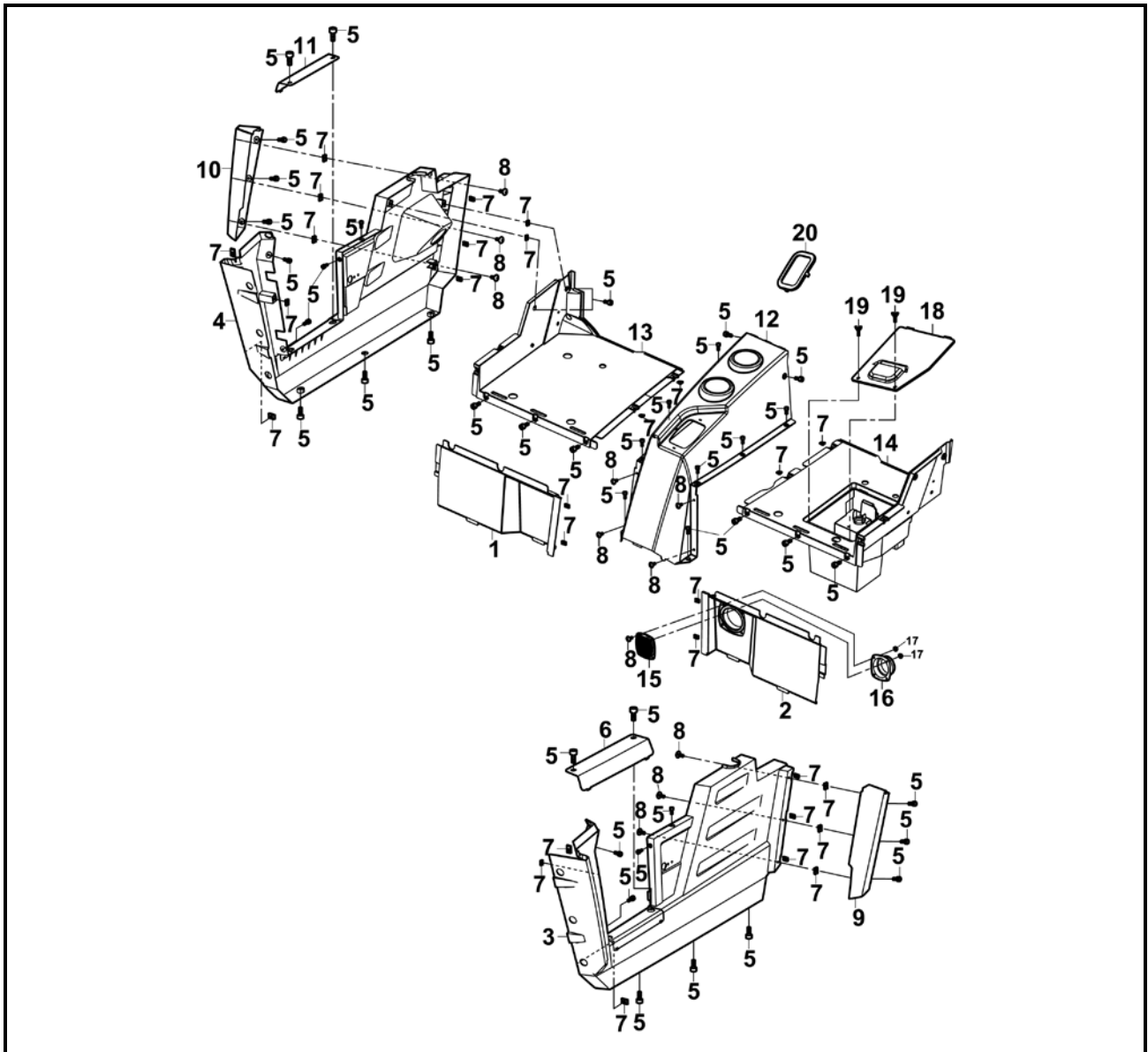

No.	Part Name	Qty	Remarks
11	Side decoration plate (R)	1	
12	Middle board, seat	1	
13	Lower protective board I ,seat (R)	1	
14	Lower protective board I ,seat (L)	1	
15	Speaker cover	1	
16	Inlet pipe, clutch	1	
17	Hexagon flange nut M6	4	
18	Battery mounting plate	1	
19	Bolt M6×20	2	
20	Gearshift decoration cover	1	

# CHASSIS

## Cargo Bed 1

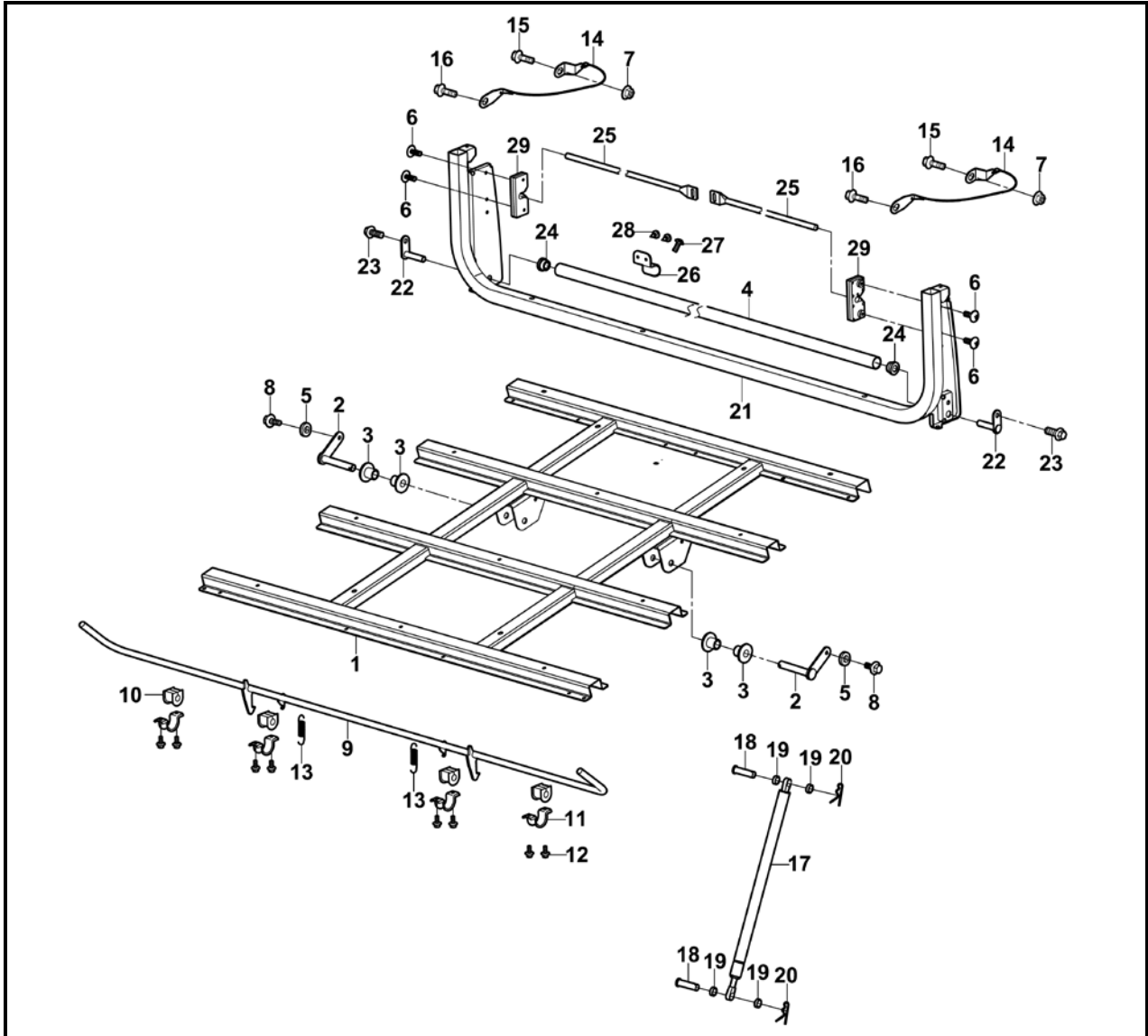

No.	Part Name	Qty	Remarks
	<b>Removing the cargo bed 1</b>		
1	Cargo bed plate assy	1	
2	Cargo bed rotating shaft assy	2	
3	Nylon collar bushing $\Phi 12 \times \Phi 18 \times \Phi 34 \times 22$	4	
4	Tube	1	
5	Spring washer 6	2	
6	Cross large plate head screw M6×16	4	
7	Hexagon flange lock nut M6	2	
8	Hexagon flange bolt M6×16	2	
9	Invert bracket assy, carrier	1	
10	U-shaped rubber sleeve	4	

# CHASSIS

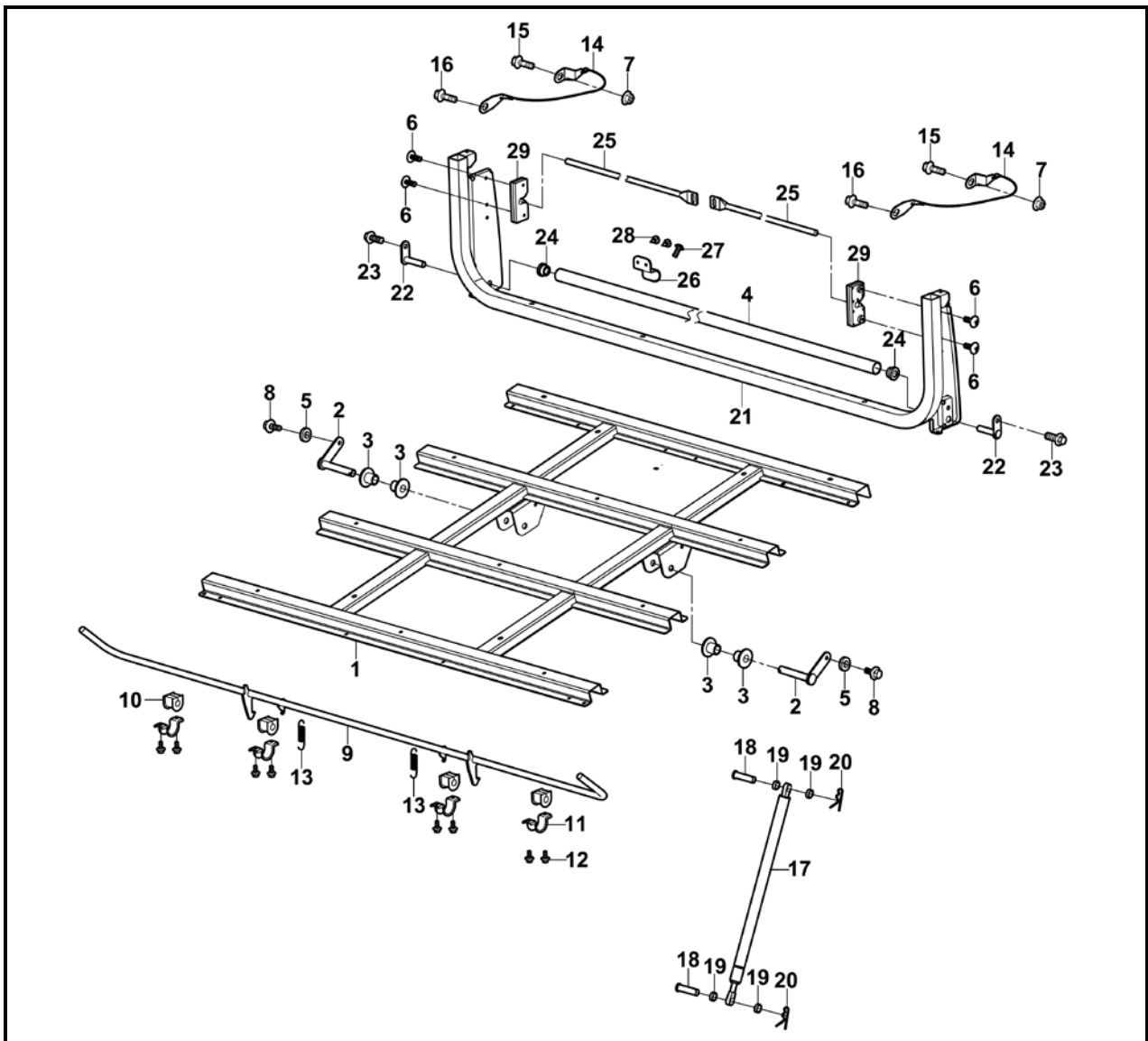

No.	Part Name	Qty	Remarks
11	Invert bracket fixing board, carrier	4	
12	Hexagon flange bolt M6×12	8	
13	Spring	2	
14	Cargo door plate cable	2	
15	Step bolt M6×12	2	
16	Step bolt M6×20	2	
17	Gas spring assy	1	
18	Fixing pin, carrier gas spring	2	
19	Rubber washer Φ12×Φ23×16	4	
20	R-pin	2	
21	Cargo bed door mounting assy	1	
22	Cargo bed mounting bracket	2	

# CHASSIS

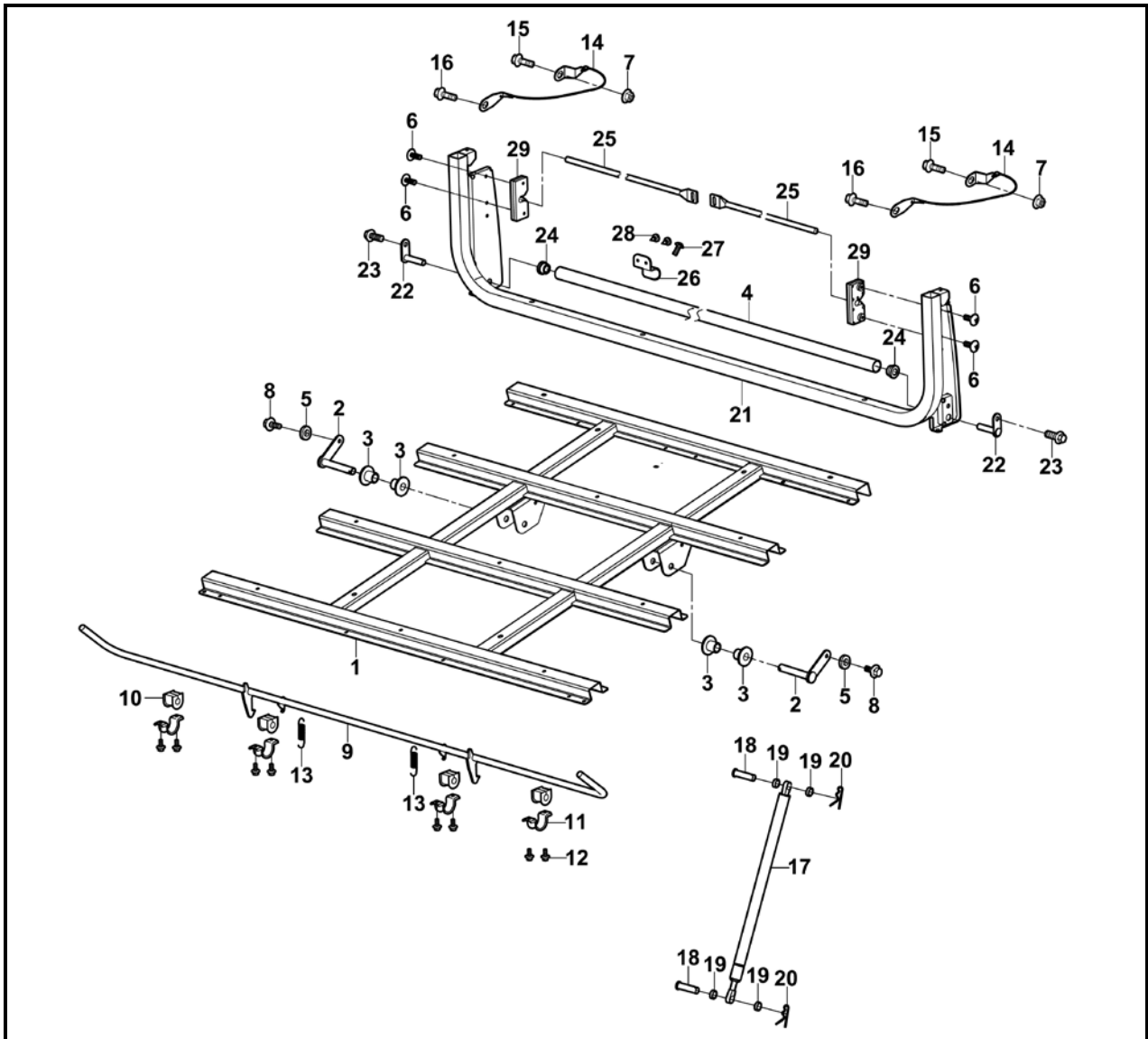

No.	Part Name	Qty	Remarks
23	Hexagon flange bolt M8×12	2	
24	Nylon collar bushing Φ12×Φ18×Φ34×22	2	
25	Rotary shaft , carrier door switch	2	
26	Rotated slotted liner tube	2	
27	Cross small plate head screw M5X12	2	
28	Self Tapping screw, cross pan headed ST4.8×13	4	
29	Rear door lock assy	2	

# CHASSIS

## Cargo Bed 2

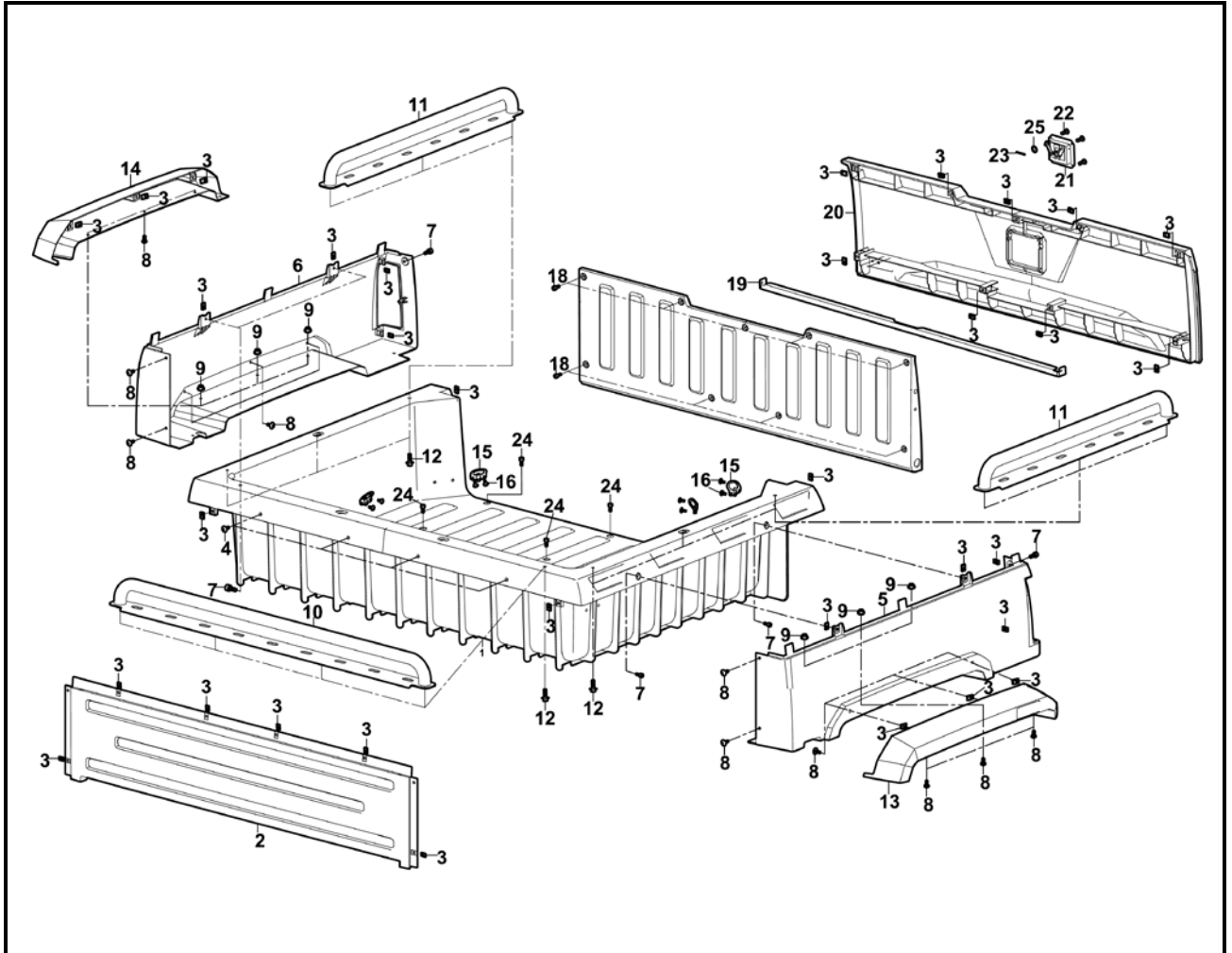

No.	Part Name	Qty	Remarks
	<b>Removing the cargo bed 2</b>		
1	Cargo bed	1	
2	Front panel, cargo bed	1	
3	Screw thread clip M6×2	32	
4	Cross large plate head screw M6×16	4	
5	Left side board assy, carrier	1	
6	Right side board assy, carrier	1	
7	Hexagon socket head bolt M6×20	6	
8	Cross large plate head screw M6×16	20	
9	Hexagon flange nut M6	18	
10	Front guard bar cargo Bed	1	
11	Side guard bar cargo Bed	2	
12	Hexagon flange bolt M8×16	10	
13	Left cargo bed decoration panel	1	

# CHASSIS

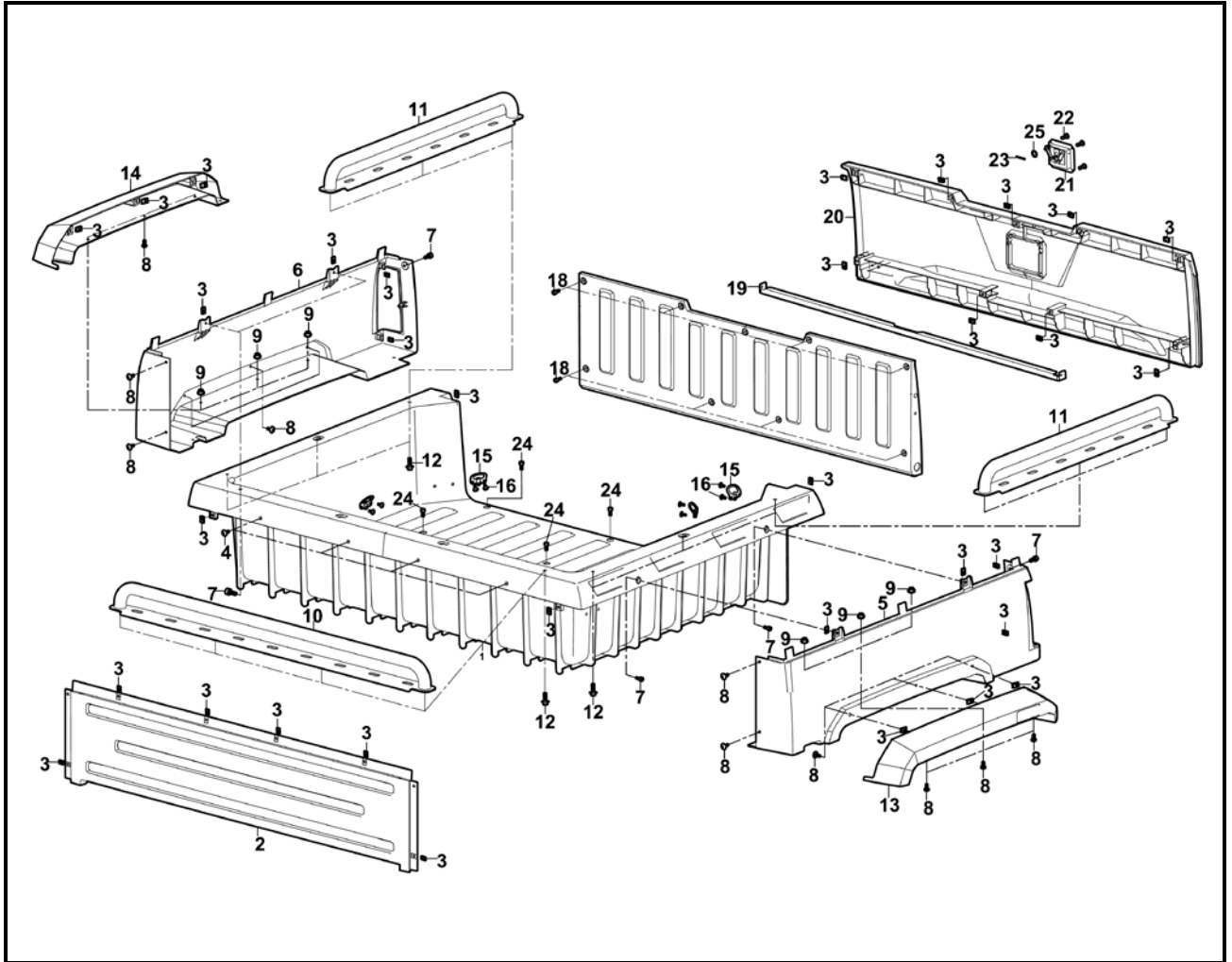

No.	Part Name	Qty	Remarks
14	Right cargo bed decoration panel	1	
15	Drawstring pothook	4	
16	Cross large plate head screw M6×16	8	
17	Liner panel, cargo bed	1	
18	Hexagon socket head bolt M6×20	9	
19	Supporting plate, cargo bed	1	
20	Decorative board, cargo bed door	1	
21	Rear door switch assy	1	
22	Cross small plate head tapping screw ST4.2×13	4	
23	Cotter pin2×25	2	
24	Hexagon socket head bolt M6×20	11	
25	Washer Φ6×Φ18×1.6	2	

# CHASSIS

---

## Raising and Lowering the Cargo Bed

- Cargo bed handle ①
- Up ②
- Down ③

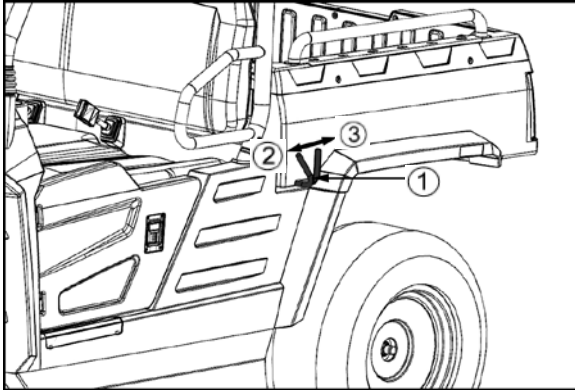

### Raise the cargo bed

1. Apply the parking brake with the engine off.
2. Pull up the cargo bed handle.

### Lower the cargo bed

Press down the cargo bed hard to make the gas spring contractive till it is locked.

### **NOTE:**

**Pull up the cargo bed handle to raise the cargo bed with the gas spring elasticity.**

---

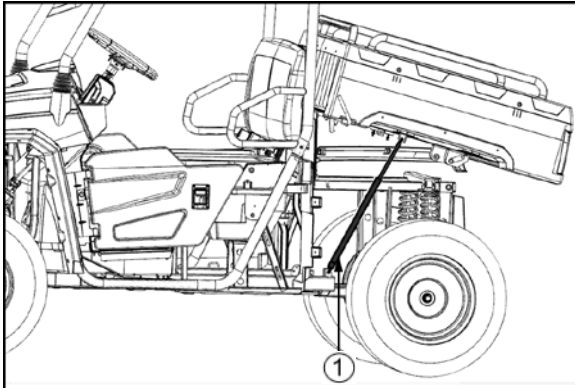

- Gas spring ①

# CHASSIS

## Head Shed Frame (Bench seat)

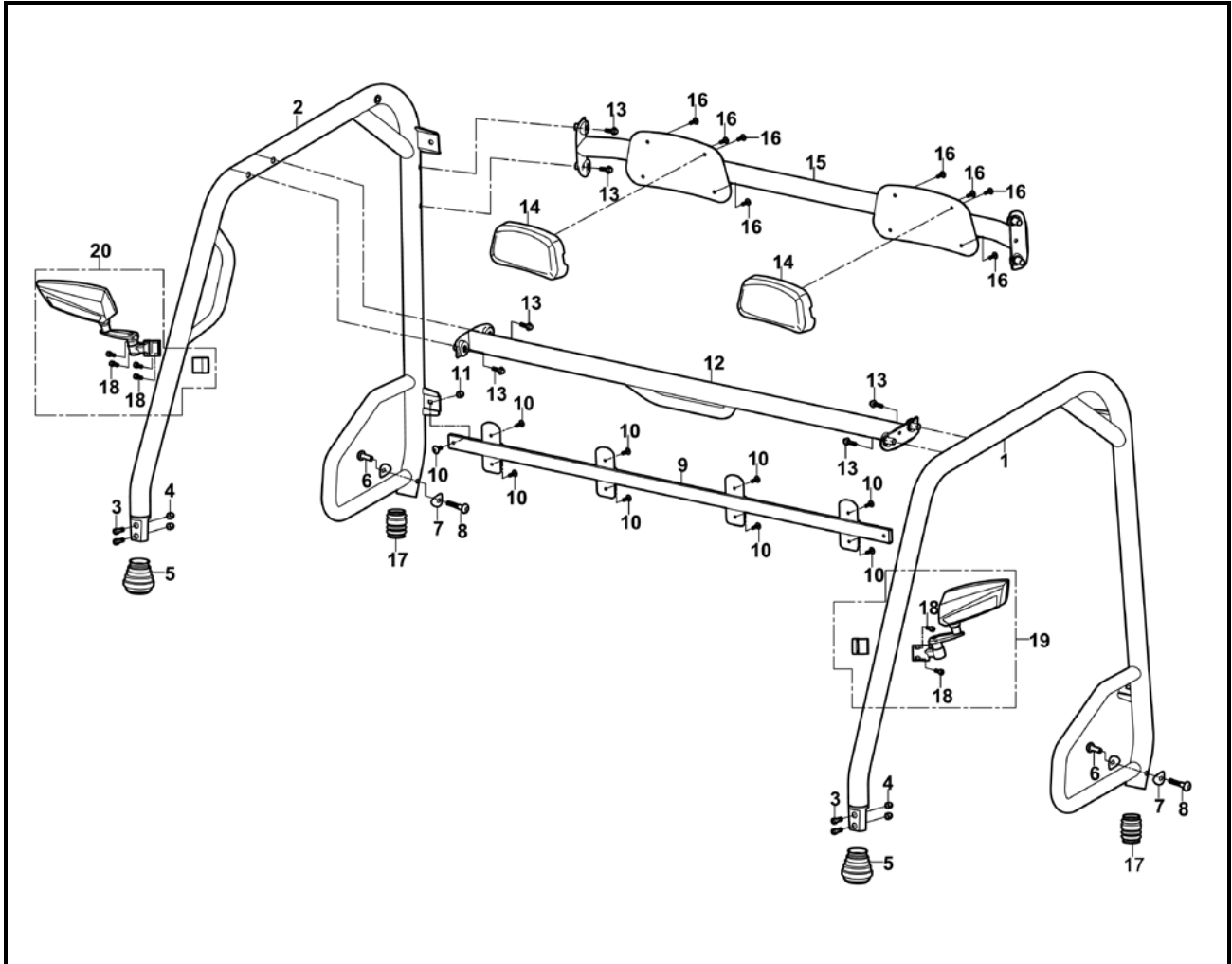

No.	Part Name	Qty	Remarks
	<b>Removing the head shed frame</b>		
1	Front segment of roof rod (L)	1	
2	Front segment of roof rod (R)	1	
3	Hexagon socket head screw M10×1.25×45	4	
4	Hexagon flange nut M10×1.25	4	
5	Waved seal I	2	
6	Hexagon socket head bolt M8×22-Φ10×16	2	
7	Curved washer	4	
8	Hexagon socket head bolt M8×25	2	
9	Backrest mounting pipe assy	1	
10	Cross large plate head screw M6×20	10	
11	Cap nut M6×12	2	
12	Horizontal tube assy I , shed	1	
13	Hexagon flange bolt M10×1.25×16	8	



# CHASSIS

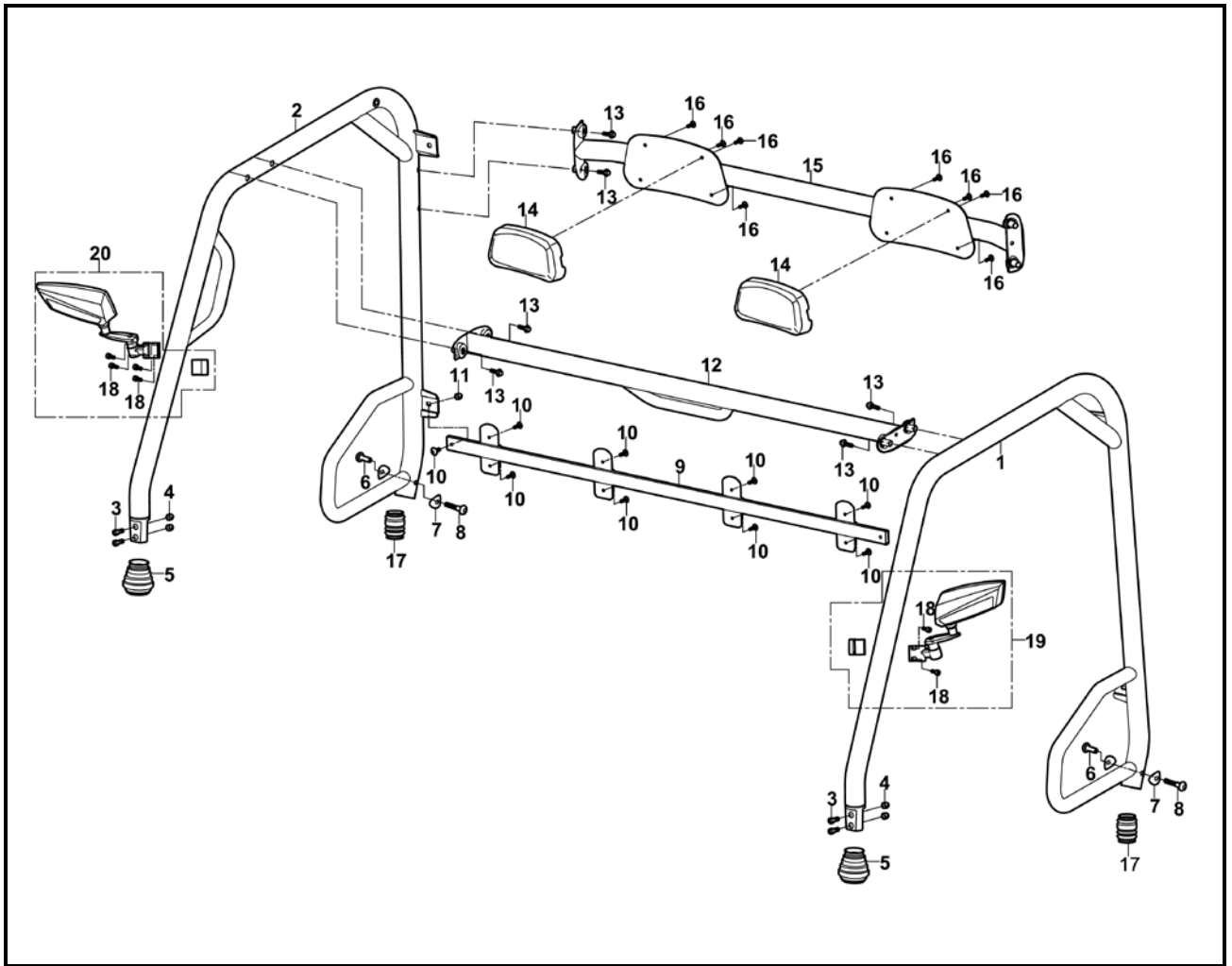

No.	Part Name	Qty	Remarks
14	Head rest	2	
15	Horizontal tube assy II, shed	1	
16	Cross large plate head screw M6×20	8	
17	Waved seal II	2	
18	Socket hexagon screw M4×12	8	
19	Left mirror assy	1	
20	Right mirror assy	1	

# CHASSIS

## Head Shed Frame (Bucket seat)

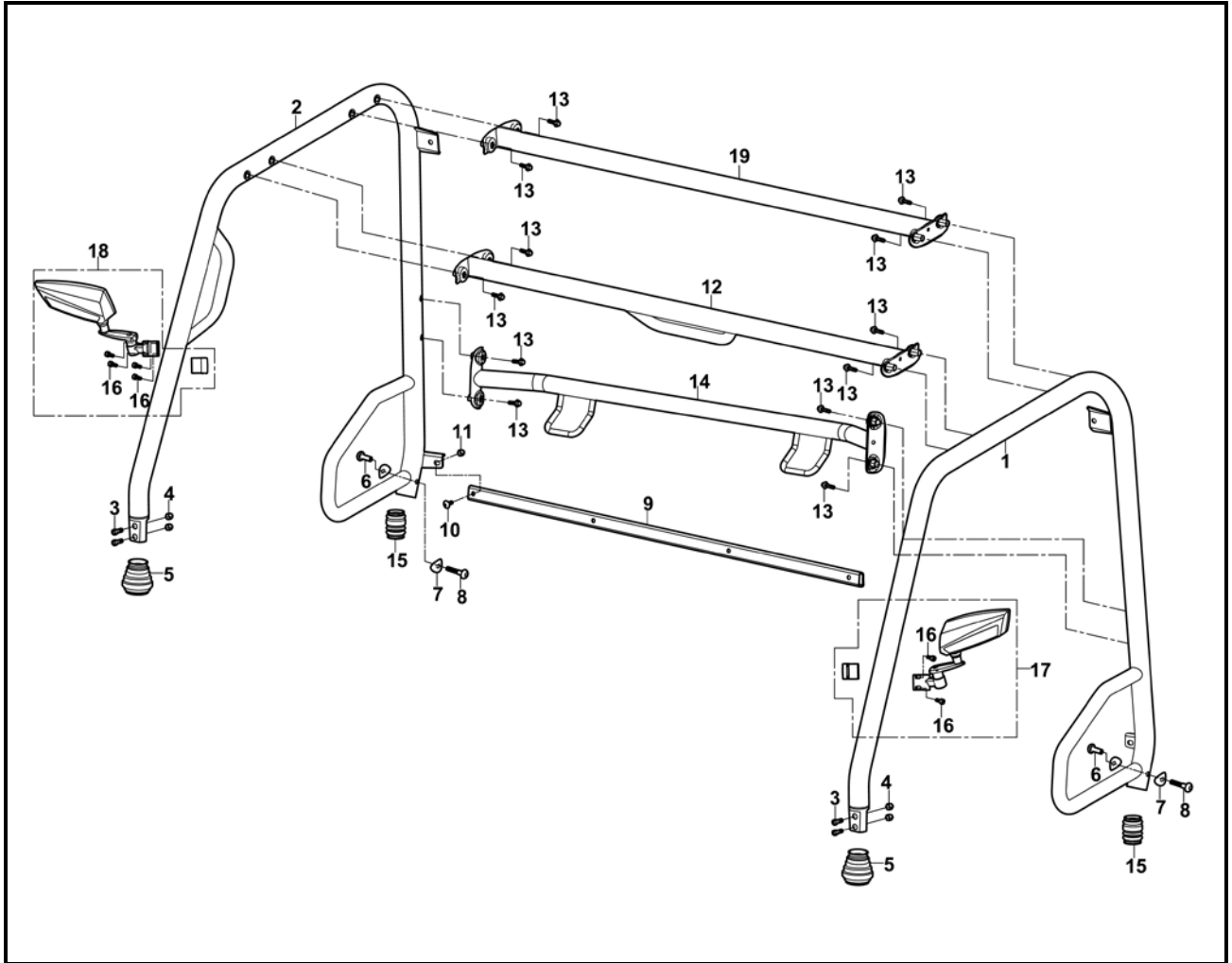

No.	Part Name	Qty	Remarks
	<b>Removing the head shed frame</b>		
1	Front segment of roof rod (L)	1	
2	Front segment of roof rod (R)	1	
3	Hexagon socket head screw M10×1.25×45	4	
4	Hexagon flange nut M10×1.25	4	
5	Waved sealing boot I	2	
6	Hexagon socket head bolt M8×22-Φ10×16	2	
7	Curved washer	4	
8	Hexagon socket head bolt M8×25	2	
9	Rear back panel mounting pipe	1	
10	Cross pad head screw M6×20	2	
11	Cap nut M6×12	2	
12	Horizontal tube assy, shed	1	
13	Hexagon flange bolt M10×1.25×16	8	

# CHASSIS

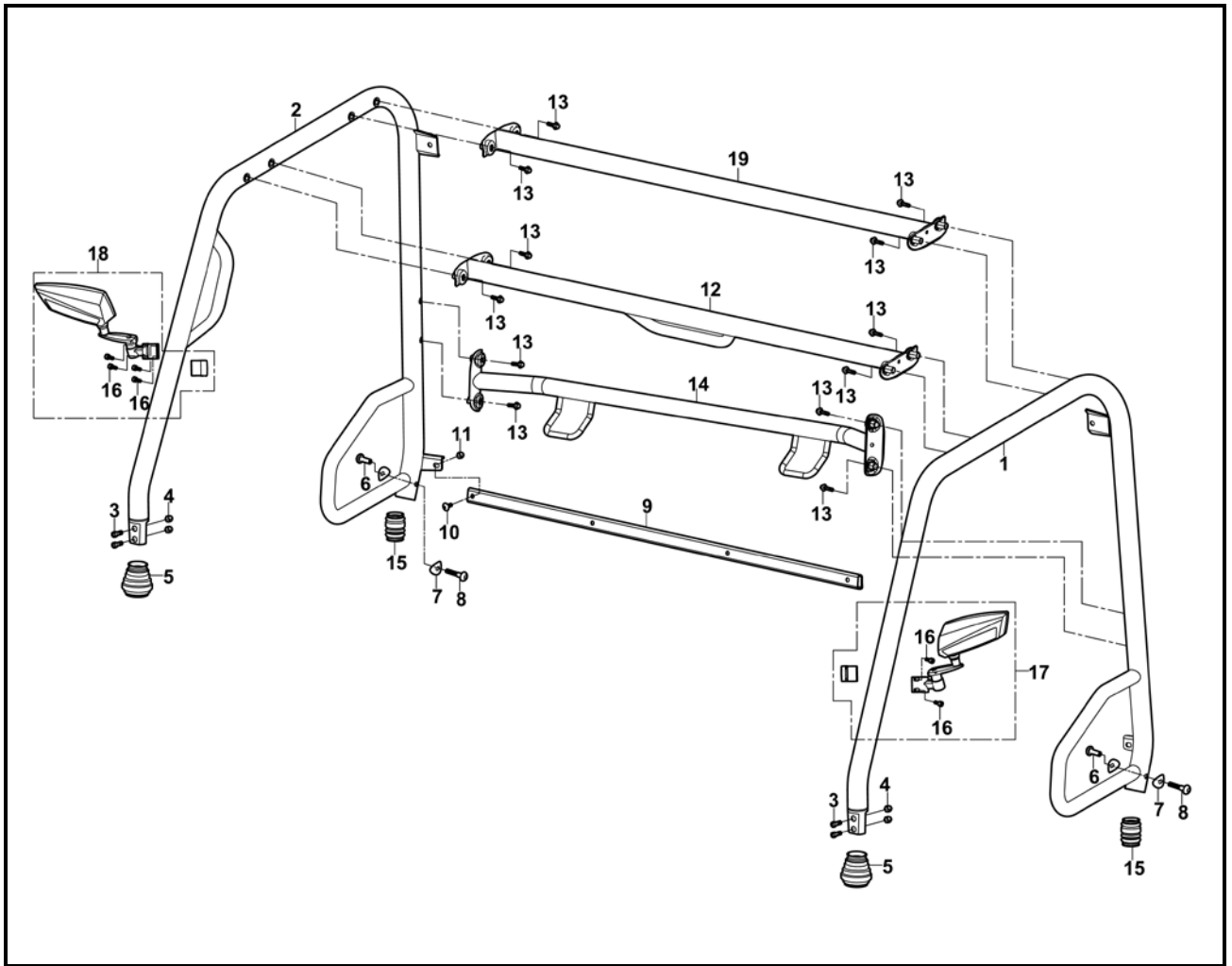

No.	Part Name	Qty	Remarks
14	Horizontal tube assy III, shed	1	
15	Waved seal II	2	
16	Socket hexagon screw M4×12	8	
17	Rear mirror assy(L)	1	
18	Rear mirror assy(R)	1	
19	Horizontal tube assy II ,shed	1	

# CHASSIS

## DIRECTION SYSTEM

### Steering Wheel part

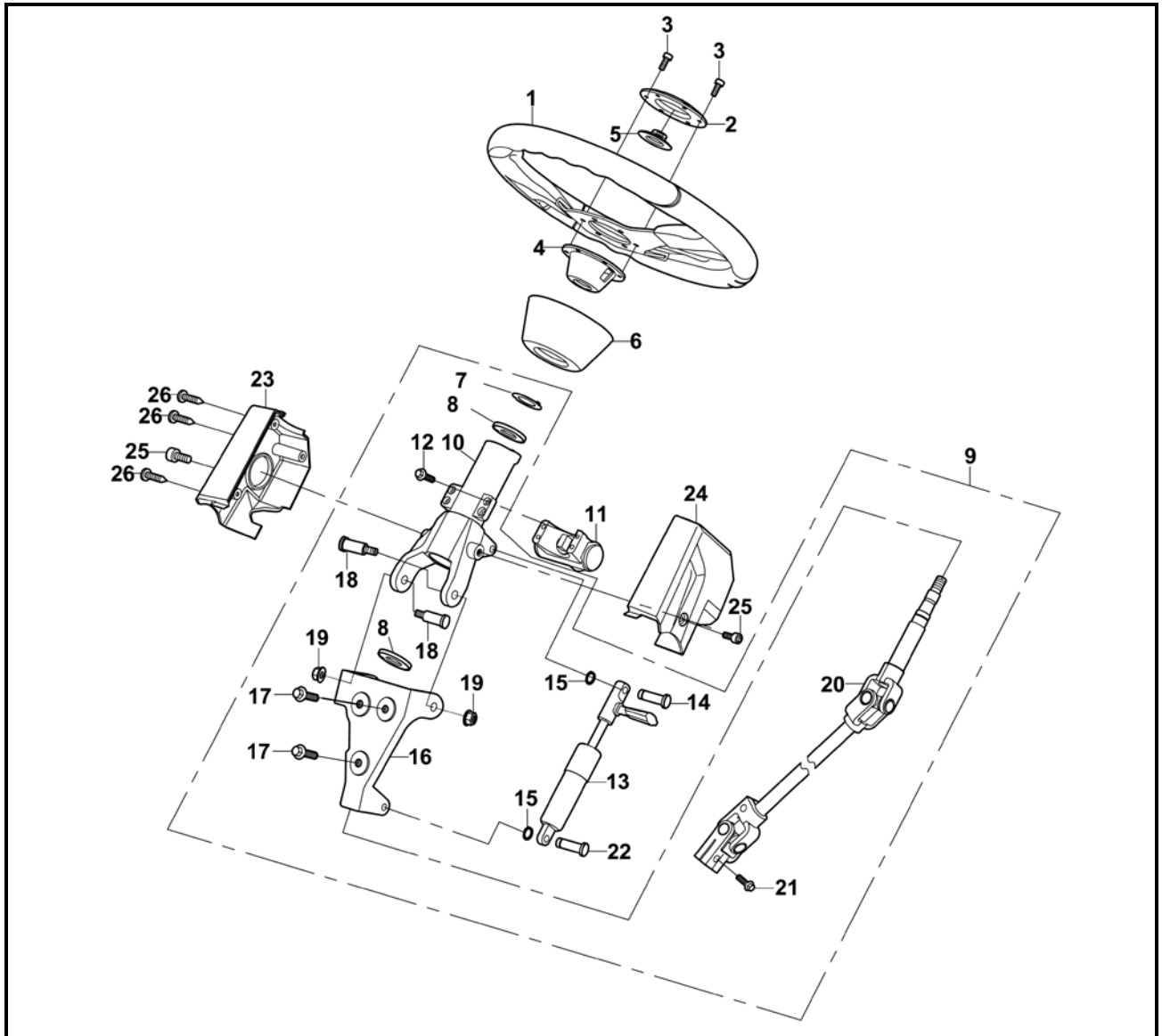

No.	Part Name	Qty	Remarks
	<b>Removing the steering wheel</b>		
1	Steering wheel comp	1	
2	Steering wheel cap	1	
3	Socket hexagon plain head screws M6×16	6	
4	Lower cover	1	
5	Horn	1	
6	Steering pole cover	1	
7	Clamp	1	
8	Bearing 6003-2Z	2	
9	Steering pole assy	1	
10	Steering pipe	1	

# CHASSIS

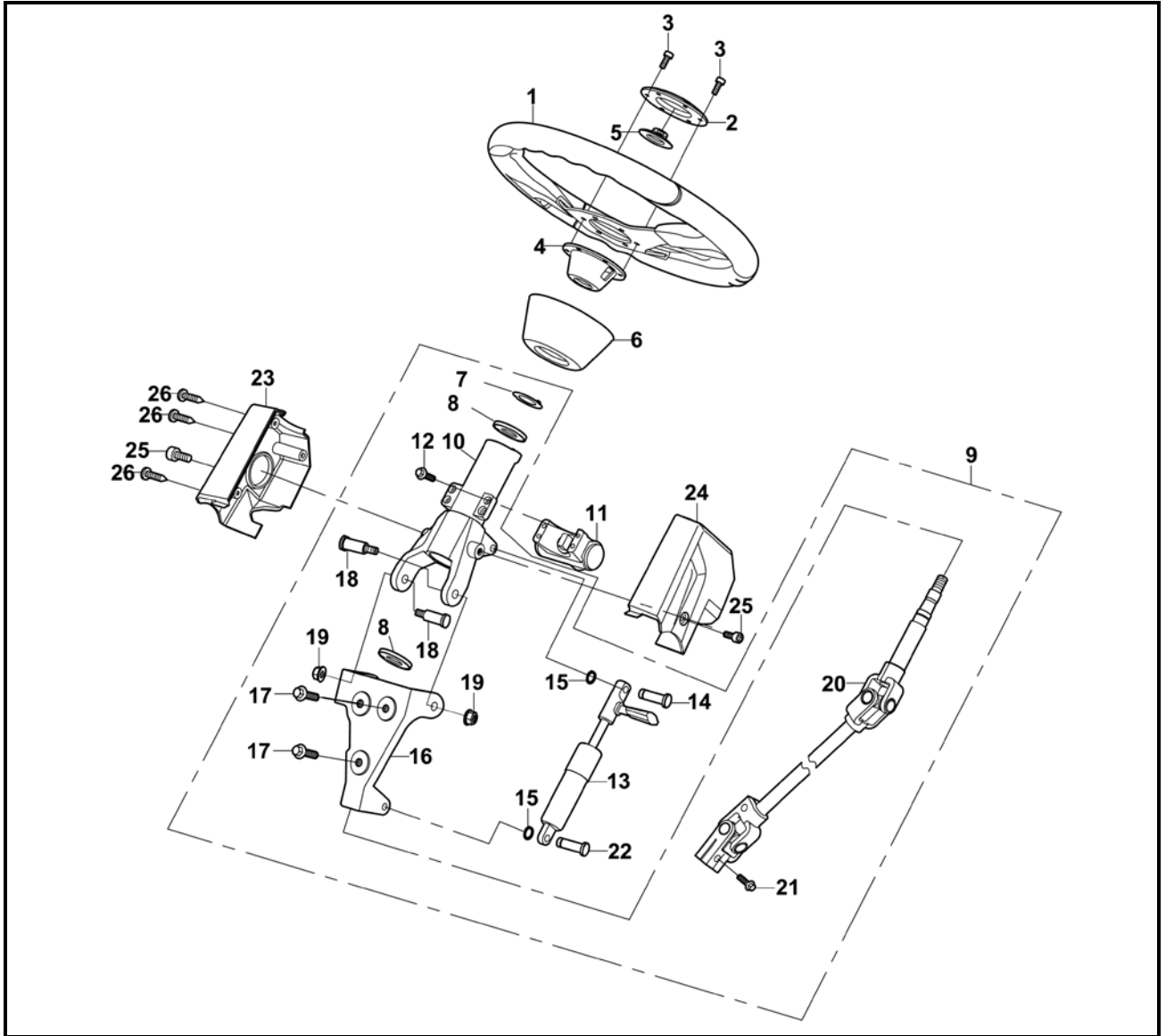

No.	Part Name	Qty	Remarks
11	Ignition switch	1	
12	Hexagon flange bolt M6×16	4	
13	Gas spring assy	1	
14	Pin shaft I	1	
15	Cotter pin Φ5×1	2	
16	Steering pipe bracket	1	
17	Hexagon flange bolt M10×1.25×16	3	
18	Bolts M6×10-Φ10×20.5	2	
19	Hexagon flange Nut M10×1.25	2	
20	Steering drive axle	1	
21	Hexagon flange bolt M8×30	1	
22	Pin shaft II	1	

# CHASSIS

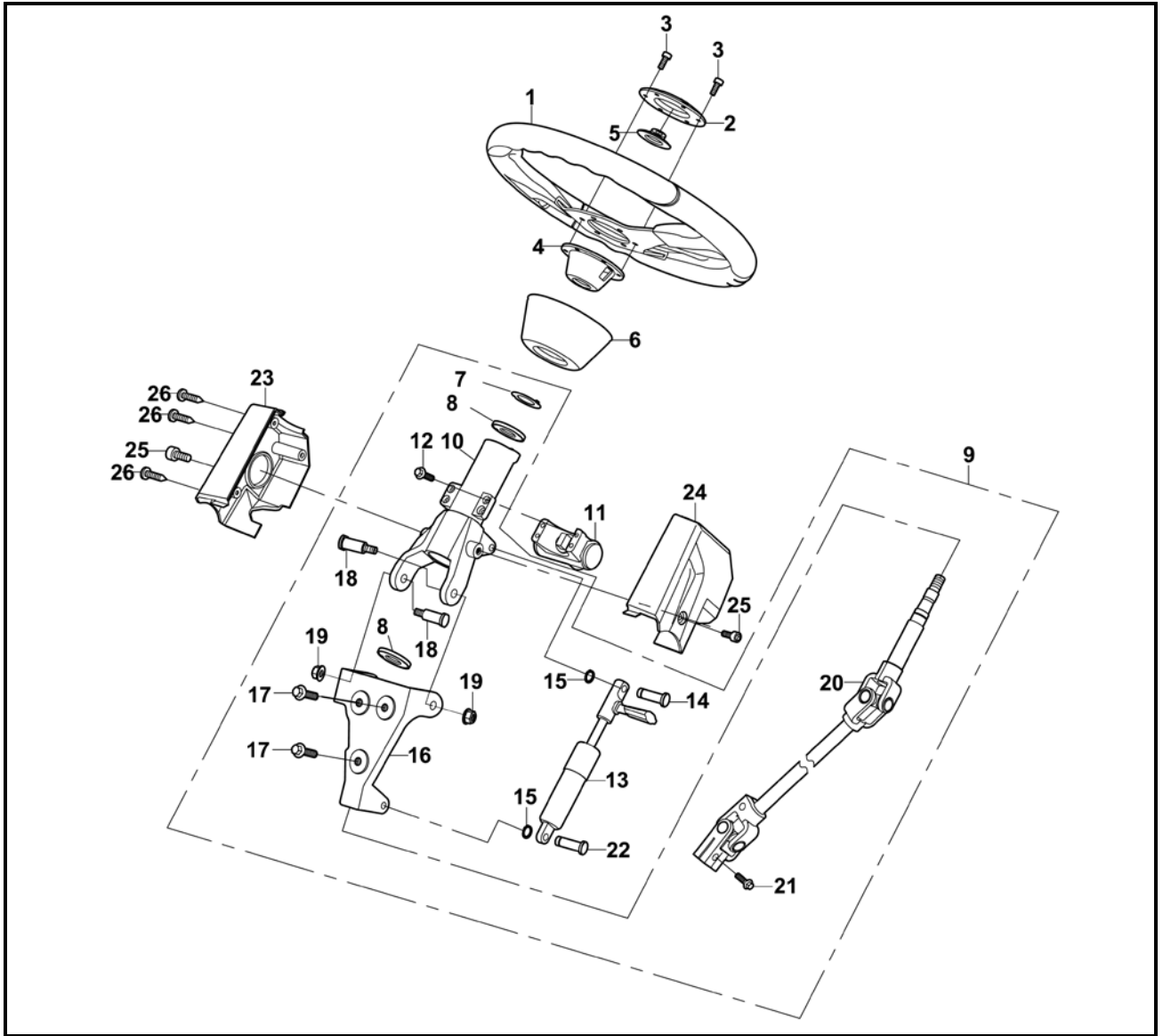

No.	Part Name	Qty	Remarks
23	Steering wheel cover (R)	1	
24	Steering wheel cover (L)	1	
25	Socket hexagon screw M6×12	2	
26	Cross small plate head tapping screw ST3.9×13	3	

# CHASSIS

## Steering mechanism part

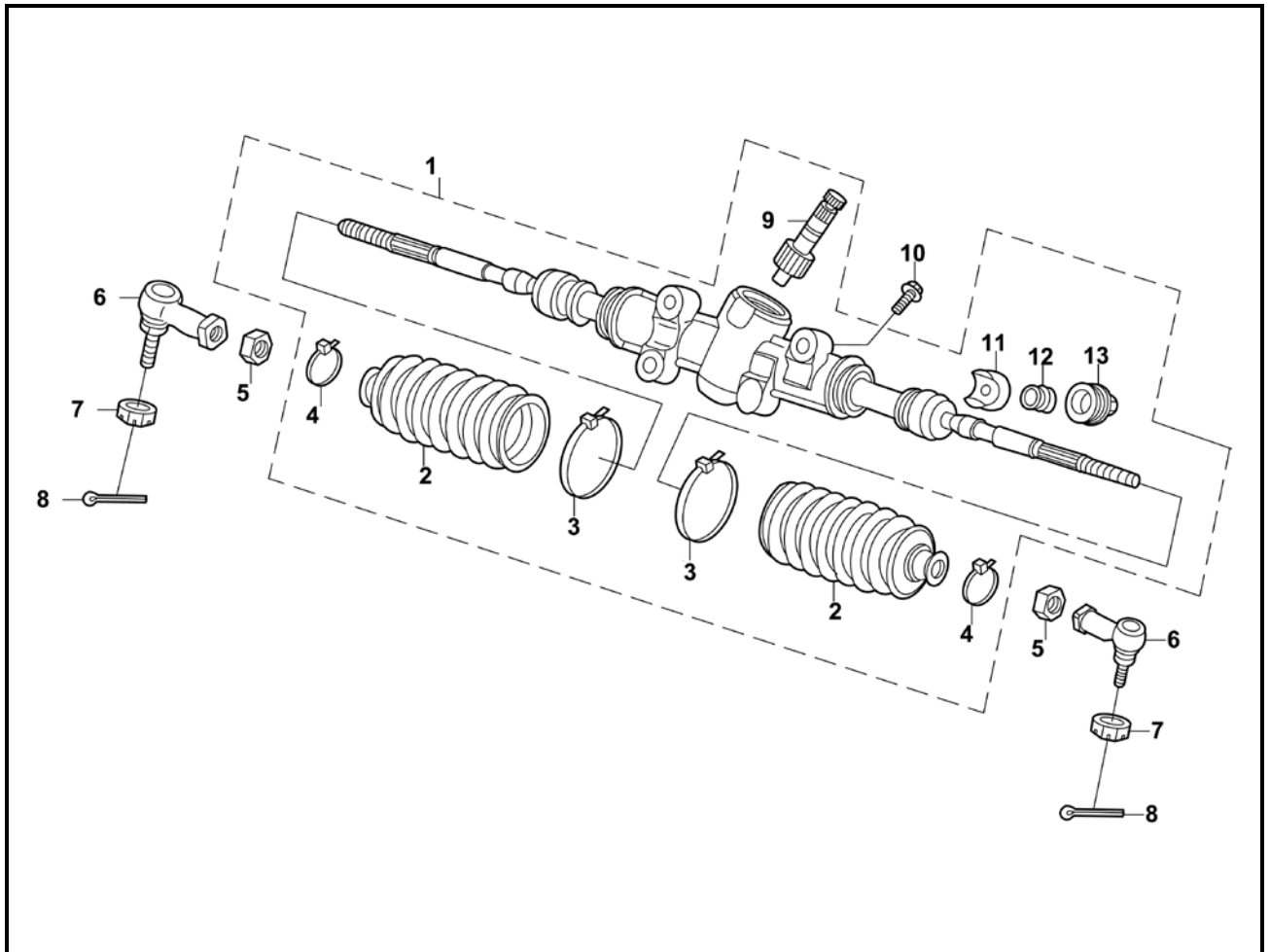

No.	Part Name	Qty	Remarks
	<b>Removing the steering mechanism</b>		
1	Steering mechanism comp	1	
2	Rubber boot	2	
3	Clip	2	
4	Clip $\Phi 16$	2	
5	Hexagonal nut M12	2	
6	Ball joint, steering mechanism	2	
7	Hexagon nut M12 $\times$ 1.25	3	
8	Cotter pin 2 $\times$ 25	2	
9	Driving gear	1	
10	Hexagon flange bolt M10 $\times$ 1.25 $\times$ 35	4	
11	Washer	2	
12	Spring	1	
13	Adjuster cap	2	

## THE STRUCTURE OF STEERING WHEEL PART DIASSEMBLING THE PARTS OF THE STEERING WHEEL

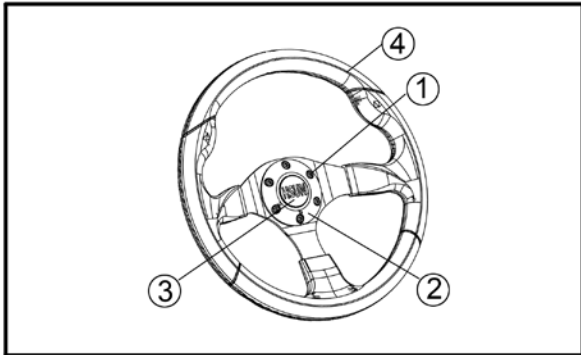

Remove:

- screw M6×16 ①
  - Decoration cover for steering wheel ②
  - Horn assembly ③
- a. Takes down the screw ①
  - b. Takes down the decoration cover for steering wheel ② and horn assembly ③
  - c. Use the special tools pull out the steering wheel ④.

## CHECKING THE PARTS OF THE STEERING WHEEL

Check:

- steering wheel ①
  - rocky ledge ②
  - reverse turning clearance ③
- crack/ break → Replace.  
loose/play → Adjust.

the steering wheel to rotate whether nimble, do not have stagnation. → Adjust the torque of the steering wheel whether obviously increase → Adjust.

### NOTE:

The steering force cutting which exerts to transfers in steering wheel outflow boundary is smaller than 245N.

The reverse running clearance whether does surpass the limited stipulation → Adjust

### NOTE:

The reverse running clearance is less than 30mm.

The grip part which is covered by the foam whether has damaged, if it is, must replace a new steering wheel.

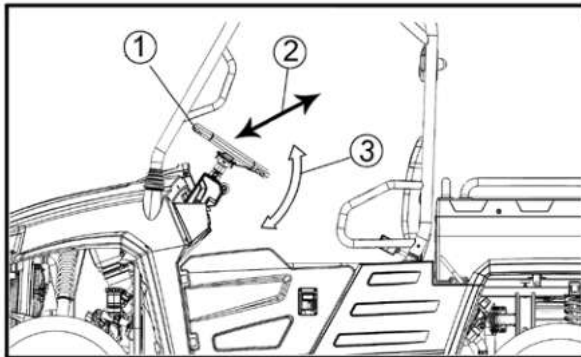



## CHASSIS

---

Inspect fastens nut of the steering wheel whether does have flaw and fissure , if it is, must replace. Check the internal spline between the steering wheel and steering column whether have damaged, if the attrition is serious, must replace the steering wheel.

**NOTE:**

**The tolerance clearance between the internal spline on the steering wheel and outer spline on the steering column is smaller than 0.1mm.**

---

**WARNING:**

*If find some problems in the check, it should be service immediately to ensure the normal work of the steering system.*

---

### DIASSEMBLING THE STEERING COLUMN PARTS

Remove:

- Front cover
  - connection covers part
  - steering wheel cover
  - display board
  - steering wheel
- a. Takes down the parts of the front panel and the connection covers part and the display board and the steering wheel center covers
  - b. Take down the steering wheel
    - bolt
    - steering shaft
  - c. Loose the bolt which is on the steering drive axle, the top of spline, draws out the cross gimbal.
  - d. Loose the fastening bolt on the steering shaft, take down the steering shaft from the frame.

# CHASSIS

---

## CHECKING AND SERVICE THE STEERING COLUMN PARTS

### 1. Check:

- steering column tube ①
- bearing ②
- central axis of the steering shaft ③
- spline ④
- loosening ⑤

The central axis of the steering shaft whether flexible and moves. If does, dismantle and check the axis, bearing and retaining ring whether ware or damaged, according to the inspection situation to instead the parts.

### 2. Check:

The two ends of the spline on the central axis whether is wear out, if so, instead the central axis.

### 3. Check:

The spline in the two ends of the central axis whether have wear, if dose, instead the central axis.

### 4. Check:

The steering shaft tube and welding line of the branch whether have crack and corrosion, if it does, instead the steering shaft tube.

## DIASSEMBLING THE STEERING DRIVE AXLE

1. Loose the clamp one piece flange bolt in the cross gimbal, internal spline on the top of the steering drive axle, pull out the top of the steering drive axle.
2. Loose the clamp one piece flange bolt in the cross gimbal, spline on the bottom of the steering drive axle, pull out the lower of the steering drive axle.

## STEERING MACHINE PARTS THE STRUCTURE OF THE STEERING

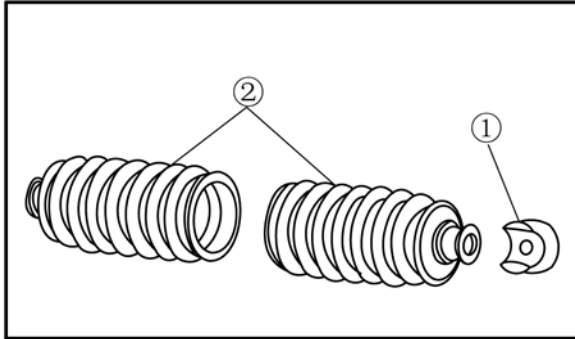

### 1. Check:

- pressure pad ①
  - Rubber dust cover ②
- Wear/damage → Replace.  
Damage/degradation → Replace

### NOTE:

When replace the dust boots of the ball , must enter 1/2 volume in lithium grease in to the dust boots.

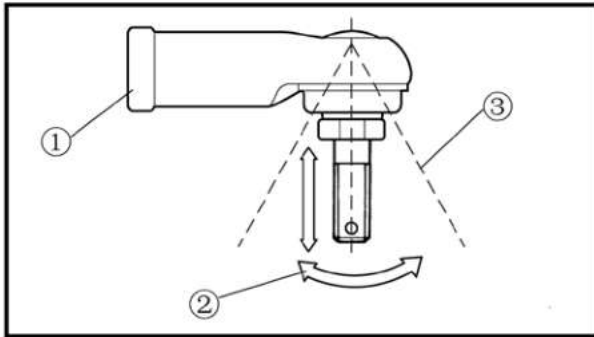

### 2. Check:

- Ball joint steering mechanism ①
  - turning ②
  - rocky ledge ③
- Free play → Replace the tie-rod end.  
Turns roughly → Replace the tie-rod end.

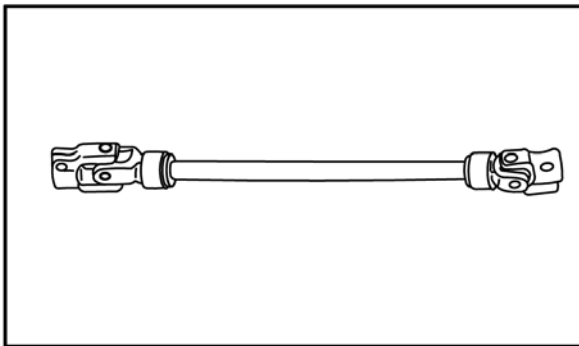

### 3. Check:

- tie-rods
- Bends/damage → Replace.

### 4. Check:

- steering joint
- Crack/distortion → Replace.

## BRAKE SYSTEM

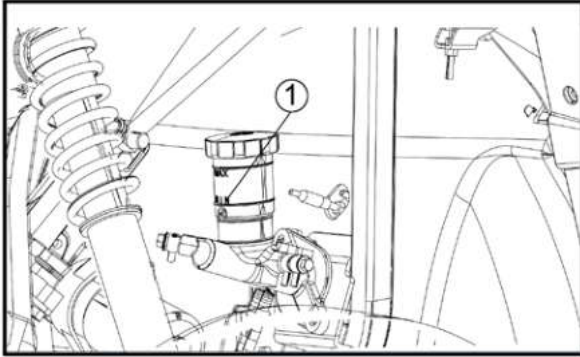

### PREPARATION FOR CHECKING BEFORE THE MAINTENANCE OF THE BRAKE SYSTEM.

Brake system is crucial to the life safety of the operator and therefore must be periodically inspected and maintained.

This vehicle uses the single return route hydraulic pressure disc brake system. Please follow the tips of inspection as below.

①. To check the amount of liquid in the oil cup. If it is min than the minimum mark, refill the box with the same type of fluid as was recommended by the manufacturer, to ensure to fluid level is higher than the minimum mark.

②. The brake should be kept between 3mm-5mm, Otherwise, please adjust the screw to meet required travel distance.

1. Inspect the brake pedal does maintain the certain counter-tension

When checks disk brake plate, the saved liquid in the oil cup will pour automatically into the pressure pipe and the liquid level along with it to reduce, the periodic inspection the disk brake plate liquid volume will be an important project.

**Must use DOT3 Brake Fluid**

2.

- rear disk brake plate ①
- thickness ②

Periodical inspection of the wear condition of rear disk brake plate is also necessary. Disk brake plate must be replaced depending on its wear condition.

3. Disk brake plate uses hydraulic pressure of the brake fluid. Therefore, fuel pipe must be periodically inspected and replaced.

Inspection method: If the oil tubing has the aging, crack or distortion, must replace the oil tubing.

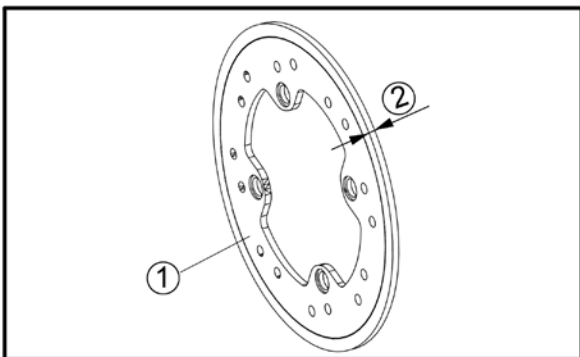

# CHASSIS

## DISK BRAKE COMPONENTS

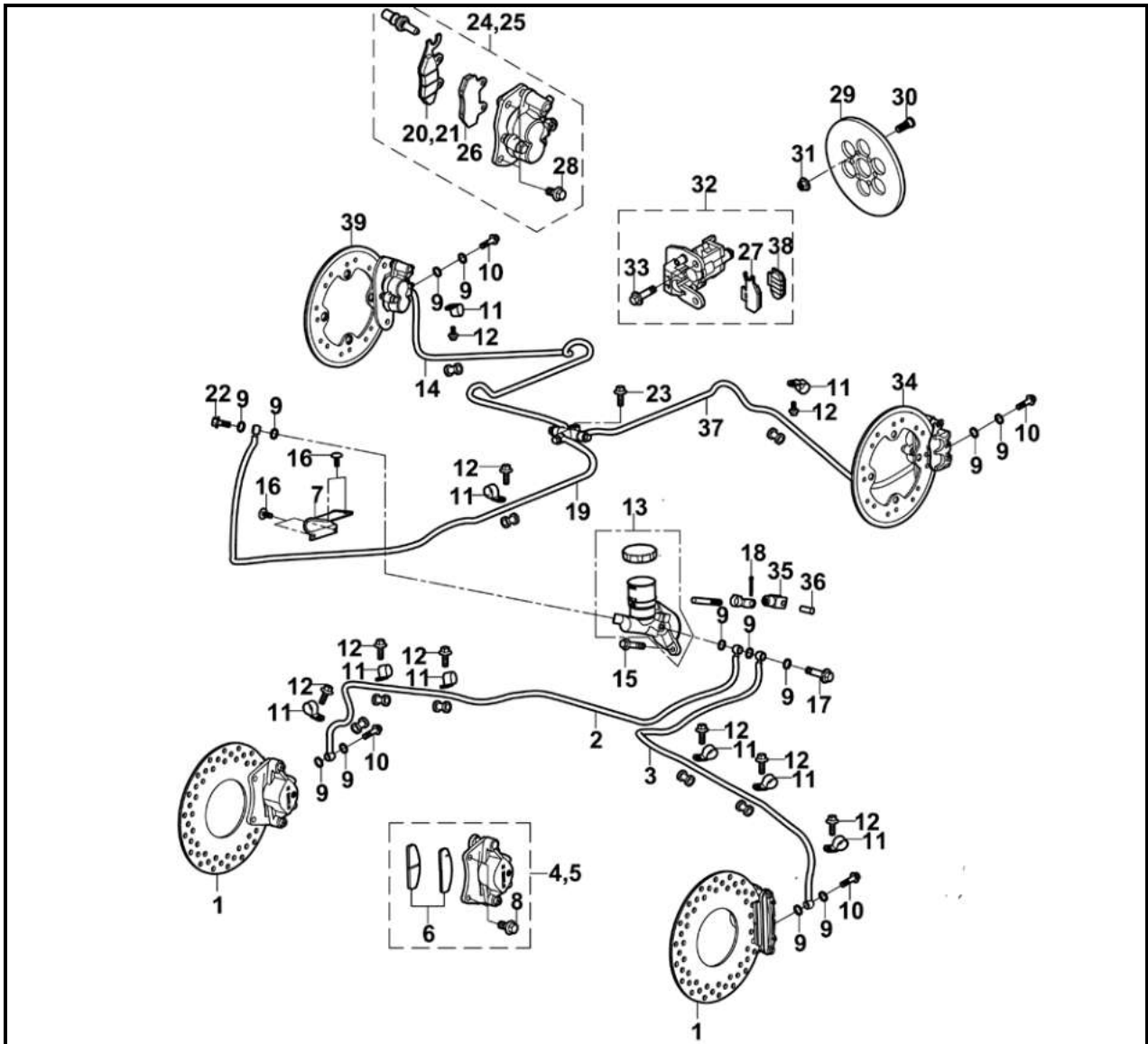

No.	Part Name	Qty	Remarks
	<b>Removing brake components</b>		
1	Front brake pad	2	
2	Front right brake oil pipe	1	
3	Front left brake oil pipe	1	
4	Front brake caliper assy(R)	1	
5	Front brake caliper assy(L)	1	
6	Front brake pad assy	4	
7	Fixed plate, rear disk brake oil pipe	1	
8	Hexagon flange bolt M10×1.25×30	4	
9	Cooper seal	13	
10	Strainer bolt	4	

# CHASSIS

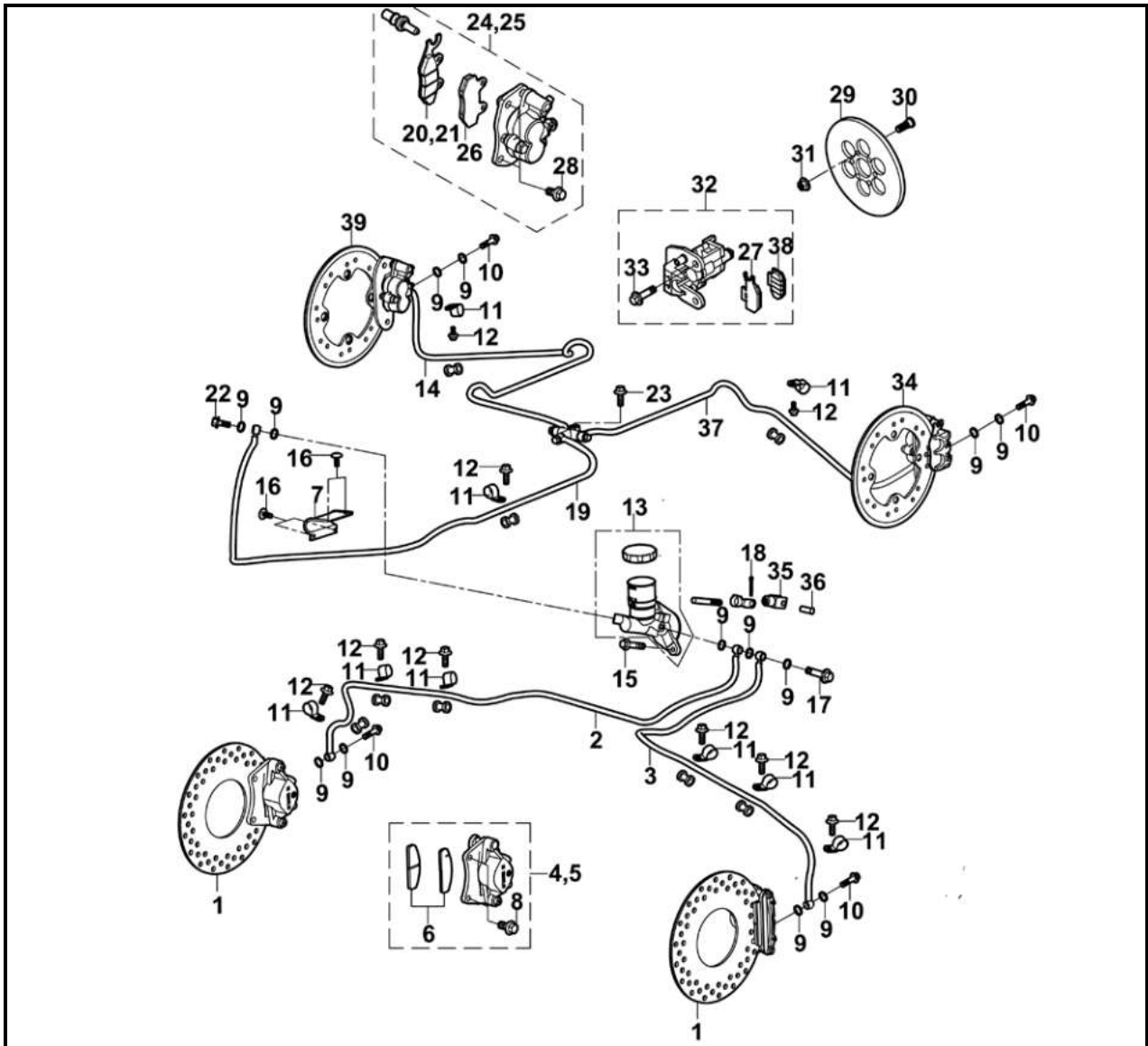

No.	Part Name	Qty	Remarks
11	Cable clip	9	
12	Hexagon flange bolt M6×16	9	
13	Rear brake pump	1	
14	Rear brake oil pipe	1	
15	Hexagon flange nut M10×1.25×25	2	
16	Cross large plate head screw M6×16	4	
17	Strainer bolt	1	
18	Cotter pin	1	
19	Rear disk brake main tube	1	
20	Outer brake pad assy (front&left)	2	
21	Outer brake pad assy (front&right)	2	
22	Strainer bolt	1	

# CHASSIS

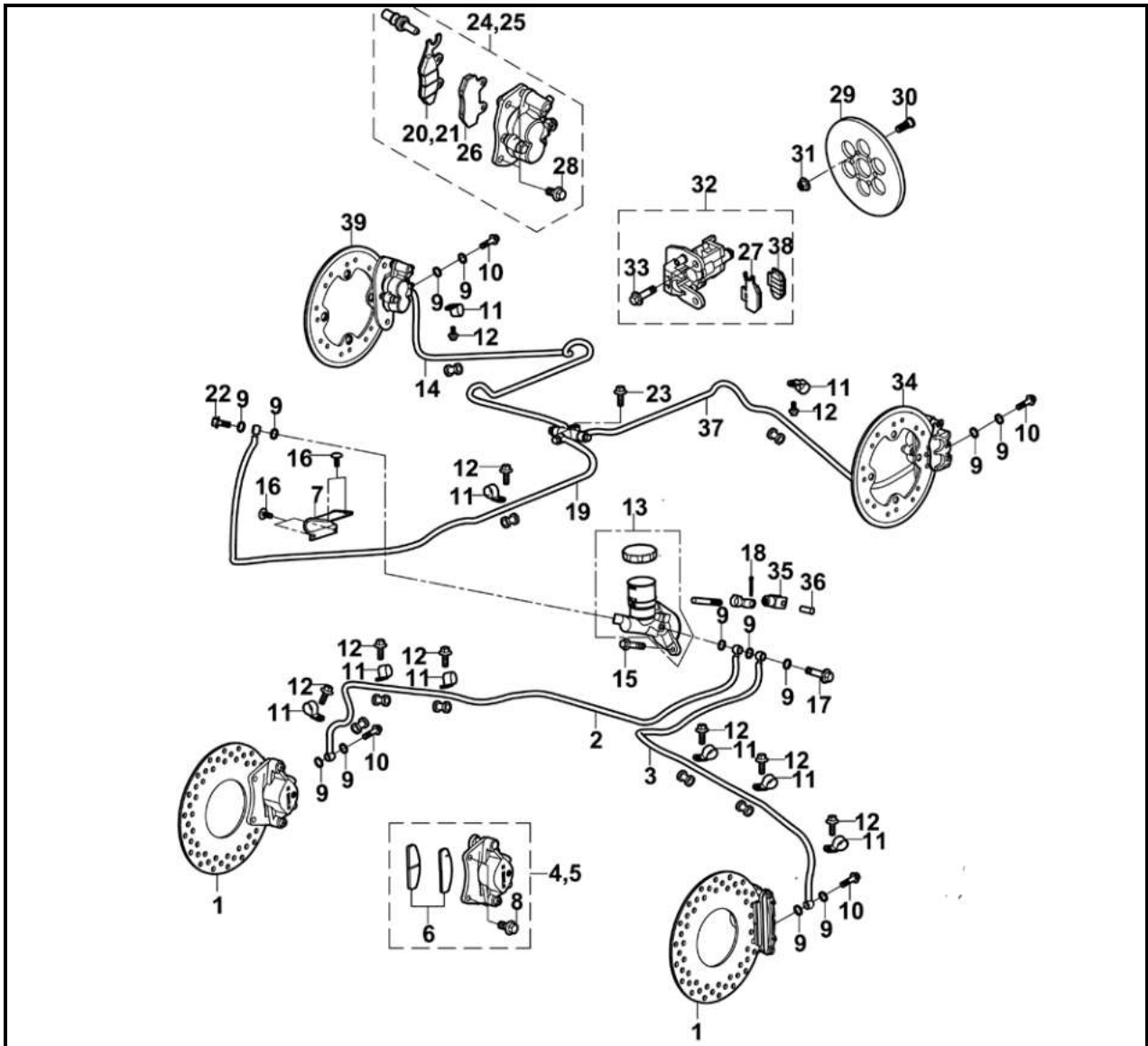

No.	Part Name	Qty	Remarks
23	Hexagon flange bolt M6×30	1	
24	Rear brake caliper assy (R)	1	
25	Rear brake caliper assy (L)	1	
26	Inner brake pad assy	2	
27	Outer brake pad assy(parking caliper)	1	
28	Bolt M10×1.25×22	4	
29	Braking plate	1	
30	Hexagon step zylinderschraube M6×14-Φ7×15	6	
31	Hexagon flange self-lock nuts M6	6	
32	Middle brake assy	1	
33	Hexagon bolt M10×1.25×55	2	
34	Rear brake plate (L)	1	

# CHASSIS

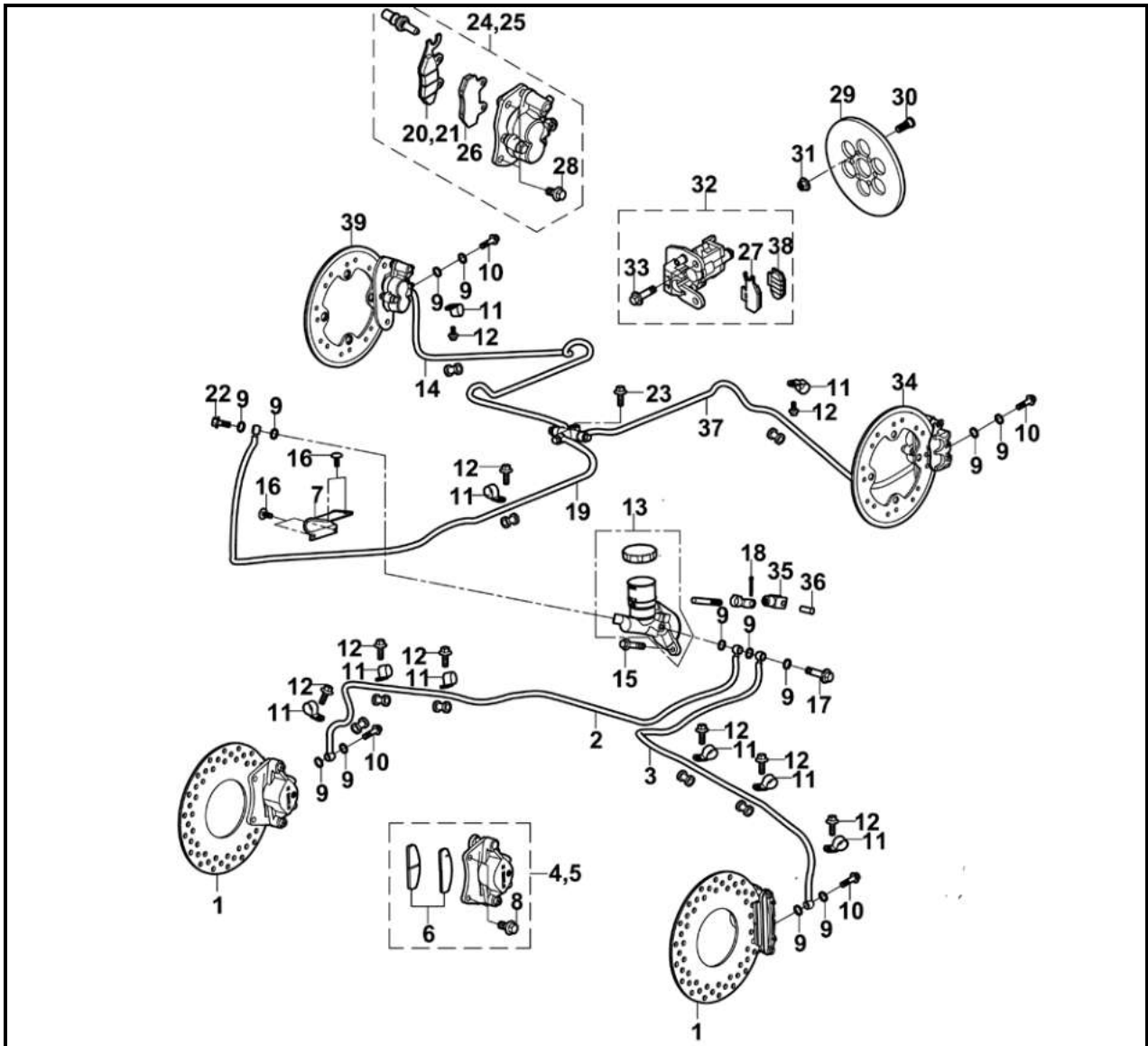

No.	Part Name	Qty	Remarks
35	Connecting fork	1	
36	Connecting fork pin	1	
37	Rear left brake hose	1	
38	Inner brake pad assy	1	
39	Rear brake plate (R)	1	



## CHASSIS

### CHECKING THE FRONT BRAKE DISC

1. Check:

- brake disc

Galling/damage → Replace.

2. Measure:

- brake disc deflection

Out of specification → Check the wheel runout.

If wheel runout is within the limits, replace the brake disc.

**Brake disc maximum deflection**  
**0.10 mm (0.004 in)**

- brake disc thickness ①
- wheel hub ②
- wheel tyre ③

Out of specification → Replace.

**Brake disc minimum thickness**  
**3.0 mm (0.12 in)**

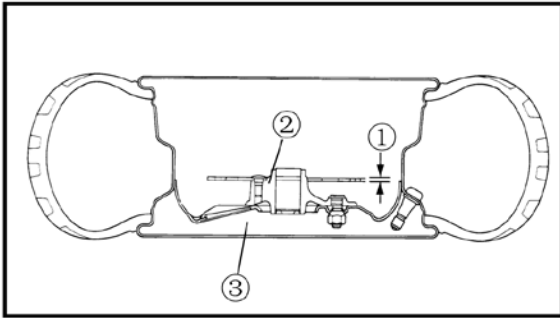

**NOTE:**

Apply the locking agent to the 30Nm bolt with screw down.

## CHASSIS

### REPLACING THE FRONT BRAKE PADS

**NOTE:**

It is not necessary to disassemble the brake caliper and brake hose to replace the brake pads.

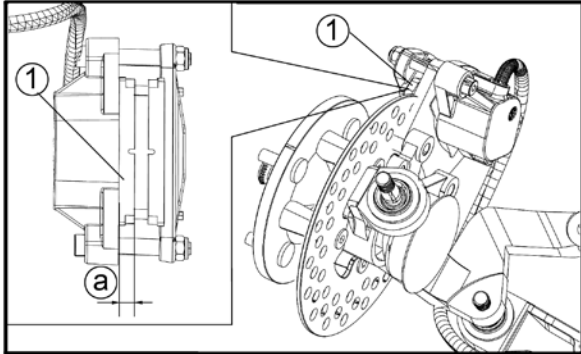

1. Check:

- brake pad ①  
Damage/wear → Replace

2. Measure:

- brake pad thickness ①  
Out of specification → Replace the brake pads as a set.

3. Install:

**Brake pad wear limit**  
**1.5 mm (0.06 in)**

3. Install:

- brake pads
- brake pad spring

**NOTE:**

**Always install new brake pads and brake pad spring as a set.**

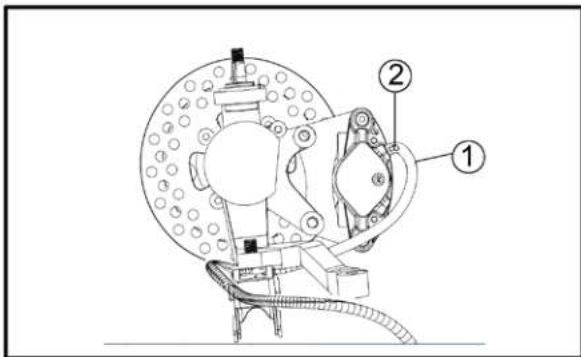

a. Connect a suitable hose ① tightly to the brake caliper bleed nozzle ②. Put the other end of this hose into an open container.

b. Loosen the brake caliper bleed screw and, using a finger, push the caliper piston into the brake caliper.

c. Tighten the brake caliper bleed screw.

**Brake caliper bleed screw**  
**6 Nm (0.6 m · kg, 4.3 ft · lb)**

d. Install the retaining bolts and brake caliper.

**Brake pad holding bolt**  
**18Nm (1.8 m · kg, 13 ft · lb)**

## CHASSIS

---

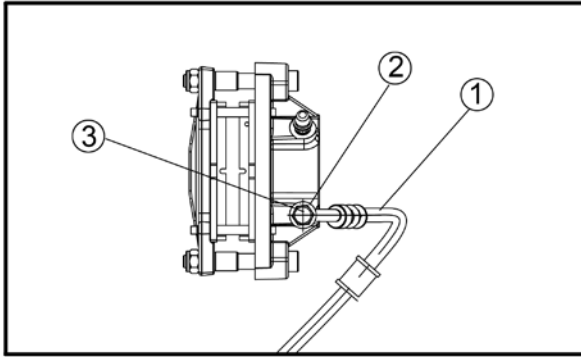

### INSTALLING THE FRONT BRAKE CALIPERS

The following procedure applies to both of the front brake calipers.

1. Install:

- brake caliper assembly
- bolt flange

**48Nm (4.8m · kg, 35 ft · lb)**

- brake hose ①
- copper washers ②
- union bolt ③

**NOTE:**

When installing the brake hose on the brake caliper, make sure that the brake pipe touches the projection a on the brake caliper.

---

**WARNING:**

*Proper brake hose routing is essential to insure safe vehicle operation.*

---

2. Fill:

- brake reservoir

**Must use DOT3 Brake Fluid**

**NOTE:**

Brake fluid may damage painted surfaces or plastic parts. Always clean up spilled brake fluid immediately.

---

3. Air bleed:

- brake system

4. Check:

- brake fluid level

Brake fluid level is below the “MIN” level line

→ Add the recommended brake fluid to the proper level.

## REPLACING THE REAR BRAKE PADS

### NOTE:

It is not necessary to disassemble the brake caliper and brake hose to replace the brake pads.

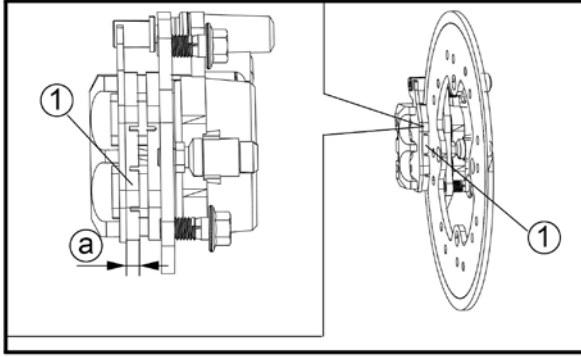

1. Check:

- brake pad ①  
Damage/wear → Replace

2. Measure:

- brake pad thickness ①  
Out of specification → Replace the brake pads as a set.

**Brake pad wear limit**  
**1.5 mm (0.06 in)**

3. Install:

- brake pads
- brake pad spring

### NOTE:

Always install new brake pads and brake pad spring as a set.

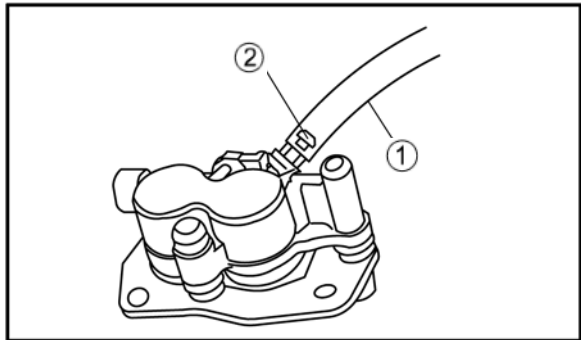

- Connect a suitable hose ① tightly to the brake caliper bleed nozzle ②. Put the other end of this hose into an open container.
- Loosen the brake caliper bleed screw and, using a finger, push the caliper piston into the brake caliper.
- Tighten the brake caliper bleed screw.

**Brake caliper bleed screw**  
**6 Nm (0.6 m · kg, 4.3 ft · lb)**

- Install the retaining bolts and brake caliper.

**Brake pad holding bolt**  
**18Nm (1.8 m · kg, 13 ft · lb)**

## CHASSIS

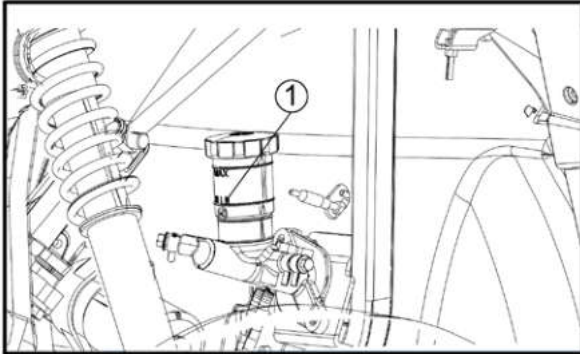

#### 4. Check:

- brake fluid level
- minimum level mark ①

**Must use DOT3 Brake Fluid**

#### 5. Check:

- brake pedal operation
- Soft or spongy feeling → Bleed the brake system.

### DISASSEMBLING THE REAR BRAKE CALIPERS

#### **WARNING:**

- *Brake caliper is one of the most important security components. Disassembly and maintenance must have a rich experience in technology and complete tool.*
- *Wrong disassembly and reassembly may cause serious injury and even death. Replace damaged brake caliper.*
- *If only replace the brake caliper of one side, please check carefully whether the braking force of right and left are balance and equal.*

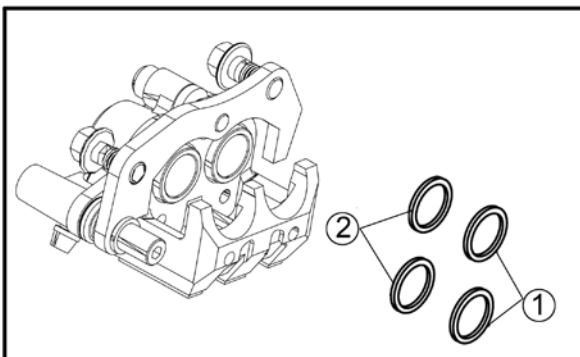

#### 1. Remove:

- brake caliper pistons
- dust seals ①
- caliper piston seals ②

a. Blow compressed air into the hose joint opening to force out the caliper piston from the brake caliper body.

#### **WARNING:**

- *Never try to pry out a caliper piston.*
- *Cover the caliper piston with a rag. Be careful not to get injured when the piston is expelled from the caliper cylinder.*

## CHASSIS

---

- b. Remove the dust seals and caliper piston seals.

**WARNING:**

***All internal brake components should be cleaned in new brake fluid only. Do not use solvents as they will cause seals to swell and distort.***

---

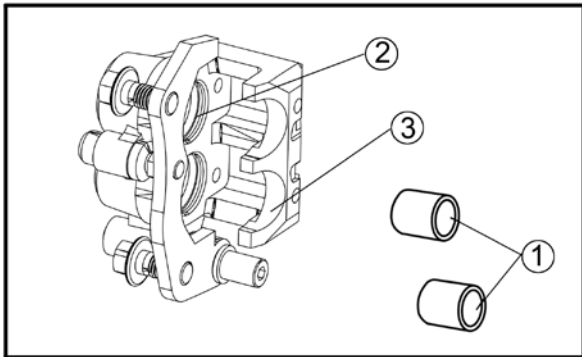

2. Check:

- brake caliper pistons ①  
Scratches/rust/wear → Replace the brake caliper assembly.
- brake caliper cylinders ②  
Wear/scratches → Replace the brake caliper assembly.
- brake caliper body ③  
Cracks/damage → Replace.
- brake fluid delivery passage (brake caliper body)  
Blockage → Blow out with compressed air.

**WARNING:**

***Replace the caliper piston seals and dust seals whenever the brake caliper is disassembled.***

---

## CHASSIS

### ASSEMBLING THE REAR BRAKE CALIPERS

#### **WARNING:**

- *All internal brake components should be cleaned and lubricated with new brake fluid only before installation.*

**Must use DOT3 Brake Fluid**

- *Replace the caliper piston seals and dust seal whenever a brake caliper is disassembled.*

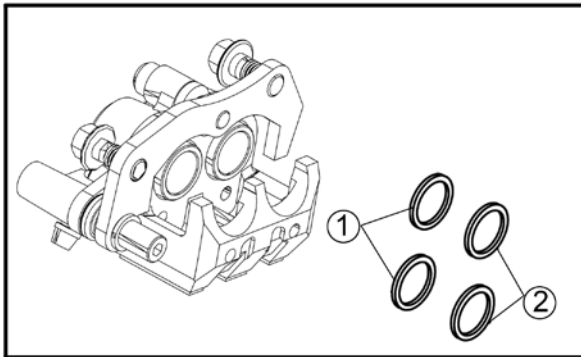

1. Install:
  - caliper piston seals ①
  - dust seals ②

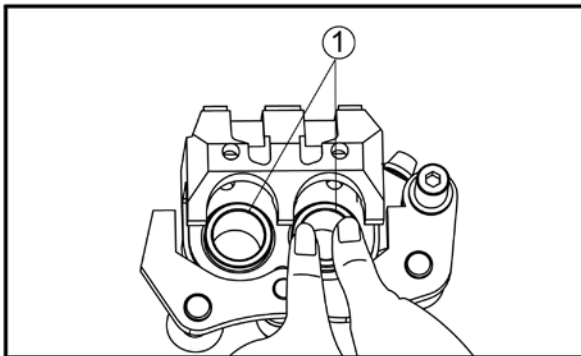

2. Install:
  - brake caliper pistons ①

### INSTALLING THE REAR BRAKE CALIPERS

The following procedure applies to both of the front brake calipers.

1. Install:
  - brake caliper assembly
  - bolt flange

**48Nm (4.8m · kg, 35 ft · lb)**

- brake hose ①
- copper washers ②
- union bolt ③

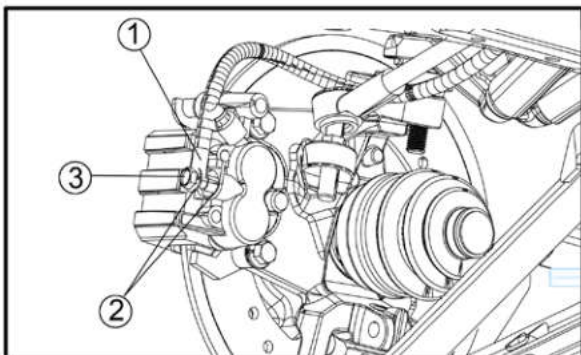

## CHASSIS

---

**NOTE:**

When installing the brake hose on the brake caliper, make sure that the brake pipe touches the projection a on the brake caliper.

---

**WARNING:**

*Proper brake hose routing is essential to insure safe vehicle operation.*

---

2. Fill:

- brake reservoir

**Must use DOT3 Brake Fluid**

**NOTE:**

Brake fluid may damage painted surfaces or plastic parts. Always clean up spilled brake fluid immediately.

---

3. Air bleed:

- brake system

4. Check:

- brake fluid level

Brake fluid level is below the “MIN” level line

→ Add the recommended brake fluid to the proper level.



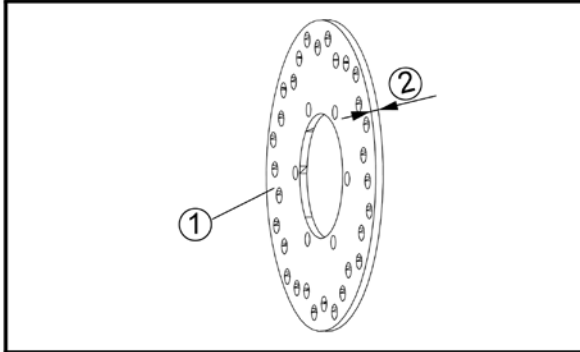

## CHECKING THE PARKING BRAKE DISC

1. Check:

- parking disc ①

Galling/damage → Replace.

2. Measure:

- parking disc deflection

Out of specification → Replace.

**Parking disc maximum deflection**  
**0.10 mm (0.004 in)**

- parking disc thickness ②

Out of specification → Replace.

**Parking disc minimum thickness**  
**4.5 mm (0.18 in)**

# CHASSIS

---

## REPLACING THE PARKING BRAKE PADS

1. Check:

- brake pad
- brake pad plate

Damage/wear → Replace

2. Measure:

- brake pad thickness

Out of specification → Replace the brake pads as a set.

**Brake pad wear limit**

**1.0 mm (0.04 in)**

3. Install:

- brake pads
- pad spring

### **NOTE:**

**Always install new brake pads, new brake pad shims, new insulators, and a new brake pad spring as a set.**

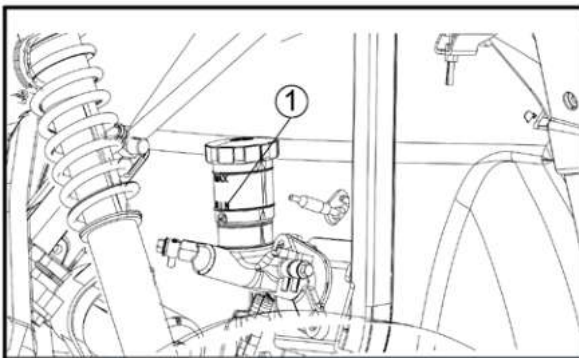

4. Check:

- brake fluid level
- minimum level mark ①

Should the fluid level falls under the minimum mark, please refill the box with the same type of fluid as was recommended by the manufacturer to ensure the fluid level is higher than the minimum mark.

***Must use DOT3 Brake Fluid***

## DISASSEMBLING THE PARKING BRAKE CALIPER

### **WARNING:**

- *Brake caliper is one of the most important security components. Disassembly and maintenance must have a rich experience in technology and complete tool.*
- *Wrong disassembly and reassembly may cause serious injury and even death. Replace damaged brake caliper.*
- *If only replace the brake caliper of one side, please check carefully whether the braking force of right and left are balance and equal.*

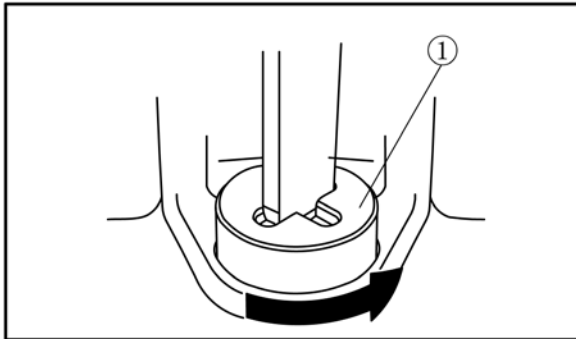

### 1. Remove:

- brake caliper piston ①
  - dust seal ②
  - caliper piston seal ③
- a. Turn the brake caliper piston counterclockwise to remove it.
  - b. Remove the dust seal and caliper piston seal.

### **WARNING:**

*All internal brake components should be cleaned in new brake fluid only. Do not use solvents as they will cause seals to swell and distort.*

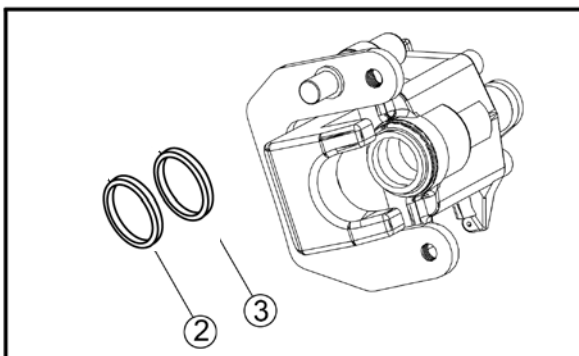

### .Check:

- brake caliper pistons ①  
Scratches/rust/wear → Replace the brake caliper assembly.
- brake caliper cylinders ②  
Wear/scratches → Replace the brake caliper assembly.
- Cracks/damage → Replace.

- brake caliper body ③
- brake fluid delivery passage (brake caliper body)

Blockage → Blow out with compressed air.

**WARNING:**

**Replace the caliper piston seals and dust seals whenever the brake caliper is disassembled.**

### ASSEMBLING THE REAR BRAKE CALIPER

**WARNING:**

- All internal brake components should be cleaned and lubricated with new brake fluid only before installation.

**Must use DOT3 Brake Fluid**

- Replace the caliper piston seal and dust seal whenever a brake caliper is disassembled.

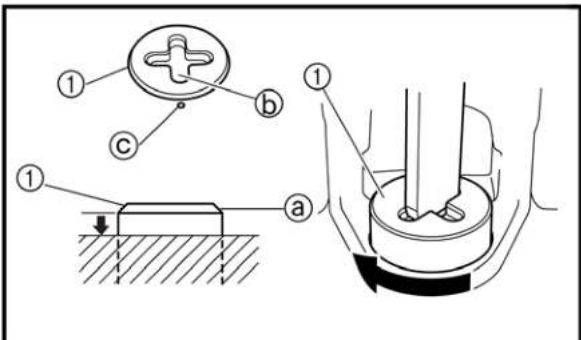
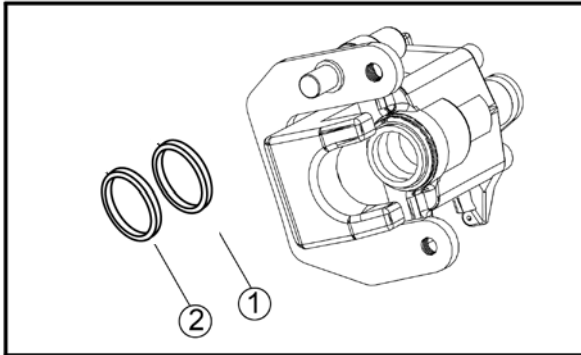

1. Install:
  - caliper piston seal ①
  - dust seal ②

2. Install:
  - brake caliper piston ①

Turn the brake caliper piston clockwise until section **a** of the brake caliper piston is level with the surface of the brake caliper body.

**NOTE:**

**Align an end **b** of the groove in the brake caliper piston with the punch mark **c** on the brake caliper body.**

## CHASSIS

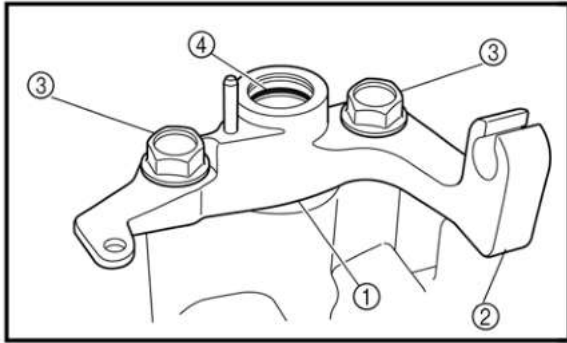

### 3. Install:

- gasket ①
- parking brake case ②
- parking brake case bolts ③

**22Nm (2.2 m · kg, 16 ft · lb)**

- O-ring ④

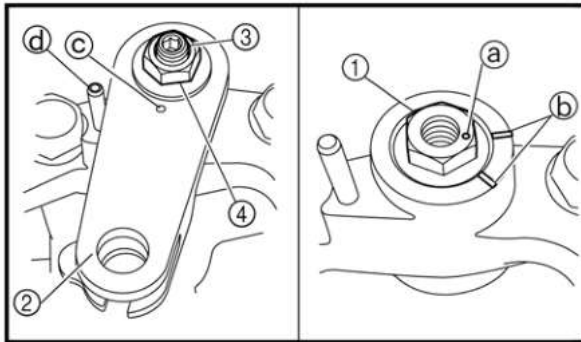

### 4. Install:

- parking brake arm shaft ①
- parking brake arm ②
- set bolt ③
- parking brake arm nut ④

#### **NOTE:**

**Apply lithium-soap-based grease to the parking brake arm shaft and set bolt.**

- a. Screw in the parking brake arm shaft counterclockwise completely so that the punch mark ① on the parking brake arm shaft is between the alignment marks ②.

#### **NOTE:**

**The hole for the parking brake arm shaft has multiple threads. If the punch mark ① on the parking brake arm shaft is not between the alignment marks ② when the parking brake arm shaft is screwed in completely, remove the parking brake arm shaft and screw it in from a different starting position.**

- b. Turn the parking brake arm shaft approximately 60° clockwise.
- c. Install the parking brake arm to the parking brake arm shaft so that the punch mark ③ on the parking brake arm is aligned with the punch mark ① on the parking brake arm shaft.
- d. Turn the parking brake arm until it contacts the pin ④.
- e. Finger tighten the set bolt.
- f. Tighten the parking brake arm nut.

## CHASSIS

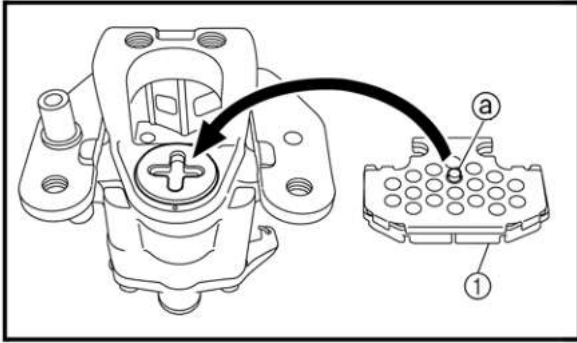

5. Install:
- brake pad (piston side) ①  
(with insulator and pad shim)

**NOTE:**

Align the projection a on the piston side of the brake pad with the groove in the brake caliper piston.

6. Install:
- brake pad holding bolts

**17Nm (1.7 m · kg, 12 ft · lb)**

### INSTALLING THE REAR BRAKE CALIPER

1. Install:
- brake caliper assembly
  - brake caliper mounting bolts

**40Nm (4.0m · kg, 29 ft · lb)**

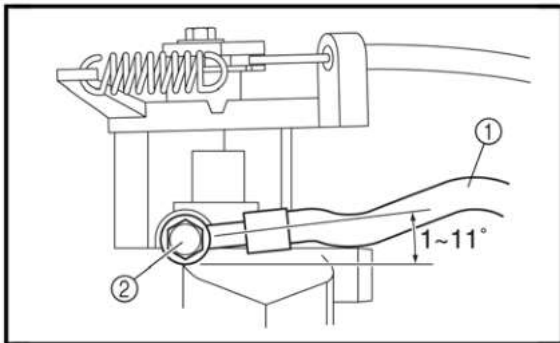

- brake hose ①
- copper washers
- union bolt ②

**48Nm (4.8m · kg, 35 ft · lb)**

**NOTE:**

Tighten the union bolt while holding the brake hose as shown.

**WARNING:**

*Proper brake hose routing is essential to insure safe vehicle operation.*

2. Fill:
- brake reservoir

**Must use DOT3 Brake Fluid**

**NOTE:**

Brake fluid may damage painted surfaces or plastic parts. Always clean up spilled brake fluid immediately.

## CHASSIS

---

3. Air bleed:

- brake system

4. Check:

- brake fluid level

Brake fluid level is below the “MIN” level line → Add the recommended brake fluid to the proper level.

5. Adjust:

- parking brake cable free play

### CHECKING THE MASTER CYLINDER

1. Check:

- brake master cylinder

Wear/scratches → Replace the brake master cylinder assembly.

- brake master cylinder body

Cracks/damage → Replace.

- brake fluid delivery passage (brake master cylinder body)

Blockage → Blow out with compressed air.

2. Check:

- brake master cylinder kit

Scratches/wear/damage → Replace as a set.

3. Check:

- brake fluid reservoir

- brake fluid reservoir diaphragm

Cracks/damage → Replace.

### ASSEMBLING THE BRAKE MASTER CYLINDER

**WARNING:**

- *All internal brake components should be cleaned and lubricated with new brake fluid only before installation.*

**Must use DOT3 Brake Fluid**

- *Whenever a master cylinder is disassembled replace the piston seals and dust seals.*
-

## CHASSIS

---

### INSTALLING THE BRAKE MASTER CYLINDER

1. Install:

- brake master cylinder

**16Nm (1.6 m · kg, 11 ft · lb)**

2. Install:

- brake pipe

**19Nm (1.9 m · kg, 13 ft · lb)**

- washer plate
- brake hose
- union bolt

**27Nm (2.7 m · kg, 19 ft · lb)**

3. Fill:

- brake fluid reservoir

**Must use DOT3 Brake Fluid**

**NOTE:**

**Brake fluid may damage painted surfaces or plastic parts. Always clean up spilled brake fluid immediately.**

---

4. Air bleed:

- brake system

5. Check:

- brake fluid level

Brake fluid level is under the “MIN” level line

Fill up.

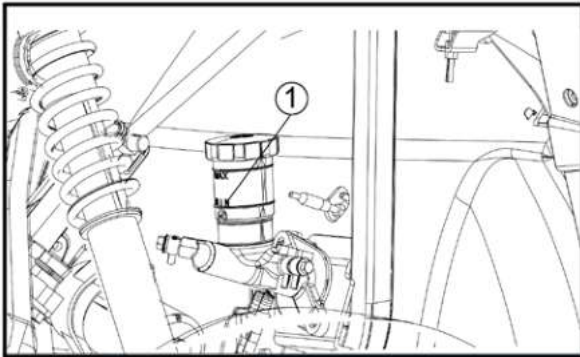



# CHASSIS

## FOOTREST PART

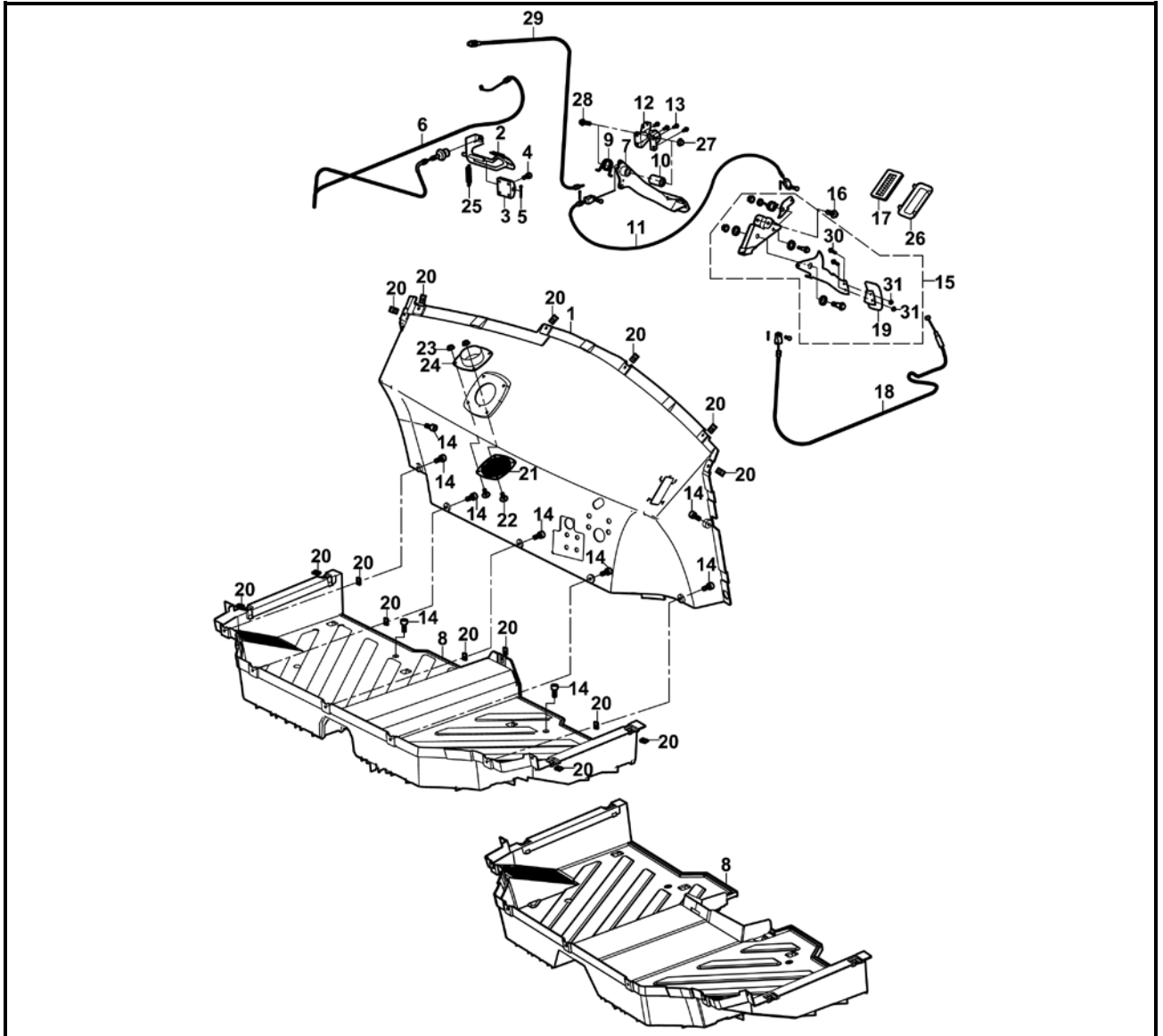

No.	Part Name	Qty	Remarks
	<b>Removing the footrest part</b>		
1	Inner fender	1	
2	Accelerator pedal welding assy	1	
3	Mounting seat assy, accelerator pedal	1	
4	Hexagon socket head bolt M6×20	4	
5	Cotter pin 2×32	1	
6	Throttle cable	1	
7	Parking pedal welding assy	1	
8	Foot pedal cover	1/2	1 for bench seat 2 for bucket seat
9	Spring Φ3×Φ30×72°	1	
10	Inner bushing, brake	1	
11	Parking brake cable	1	

# CHASSIS

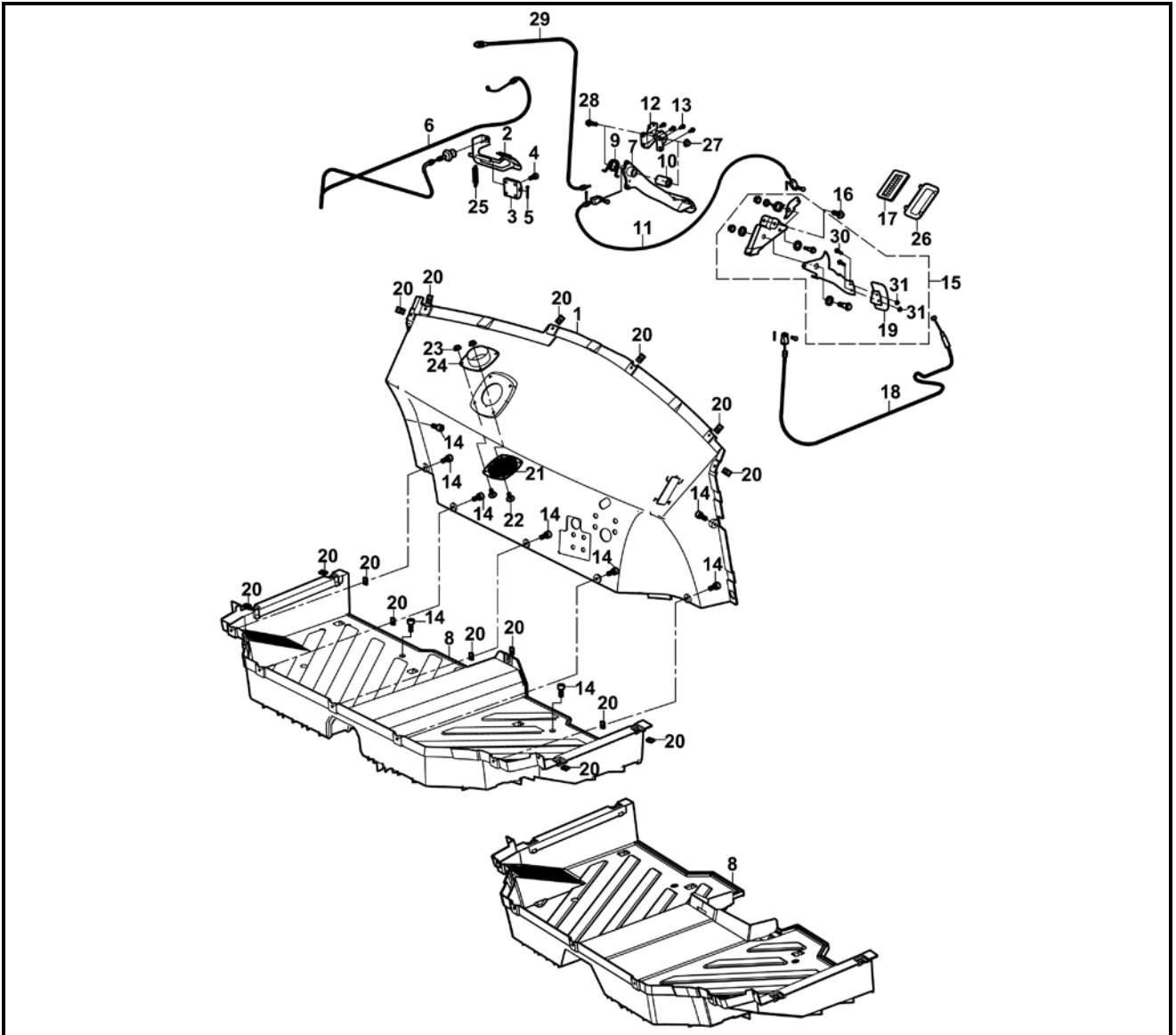

No.	Part Name	Qty	Remarks
12	Mounting seat, brake	1	
13	Hexagon flange bolt M8×16	4	
14	Hexagon socket head bolt M6×20	13	
15	Parking system	1	
16	Hexagon flange bolt M8×16	2	
17	Dustproof plate, parking pedal	1	
18	Parking cable assy	1	
19	Parking pedal	1	
20	Screw Thread clip M6×2	21	
21	Speaker cover	1	
22	Cross large plate head screw M6×16	4	
23	Hexagon flange nut M6	4	

# CHASSIS

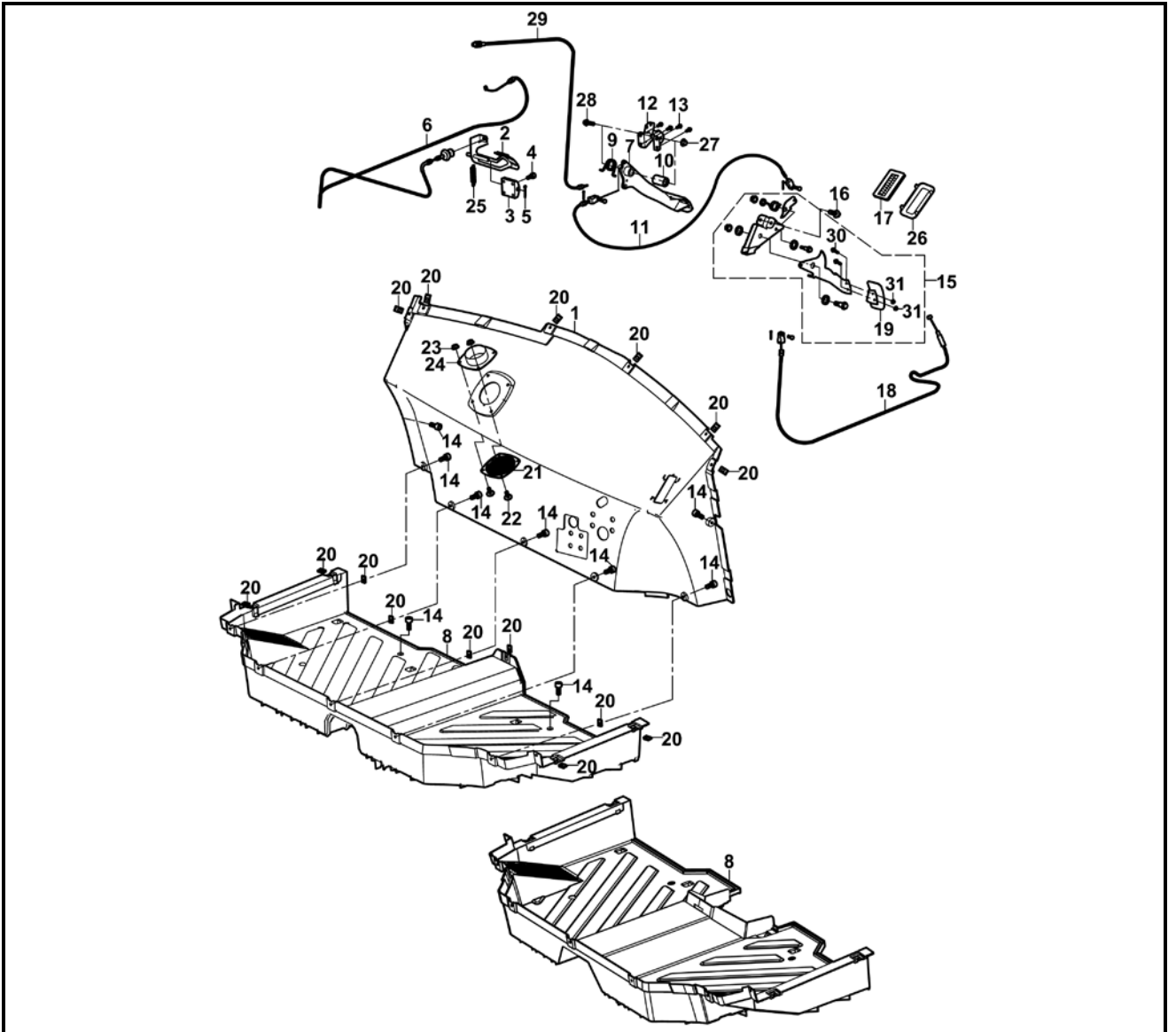

No.	Part Name	Qty	Remarks
24	Inlet cap, clutch	1	
25	Spring $\Phi 2.5 \times \Phi 23 \times 90^\circ$	1	
26	Rubber binder plate, parking	1	
27	Hexagon flange nut M10×1.25	1	
28	Hexagon bolt M10×1.25×55	1	
29	Reverse cable	1	
30	Hexagon flange bolt M6×16	2	
31	Hexagon flange nut M6	2	

## CHASSIS

---

### CHECKING THE BRAKE PEDAL

- Brake pedal ①
- Free type travel ②
- Pedal stroke ③

Inspect the brake pedals for free clearance and smooth operation.

Adjust if incorrect measurement is found.

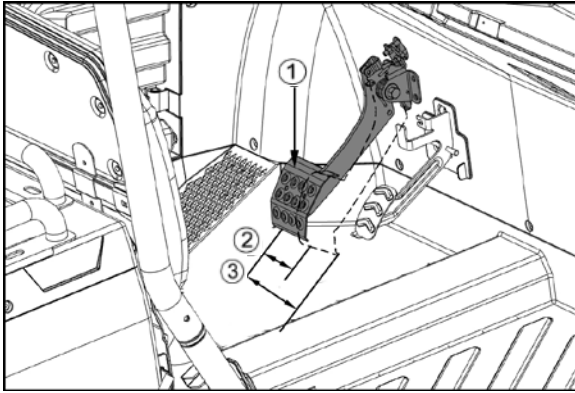

# CHASSIS

## WHEEL AND TYRE PARTS

### FRONT WHEELS

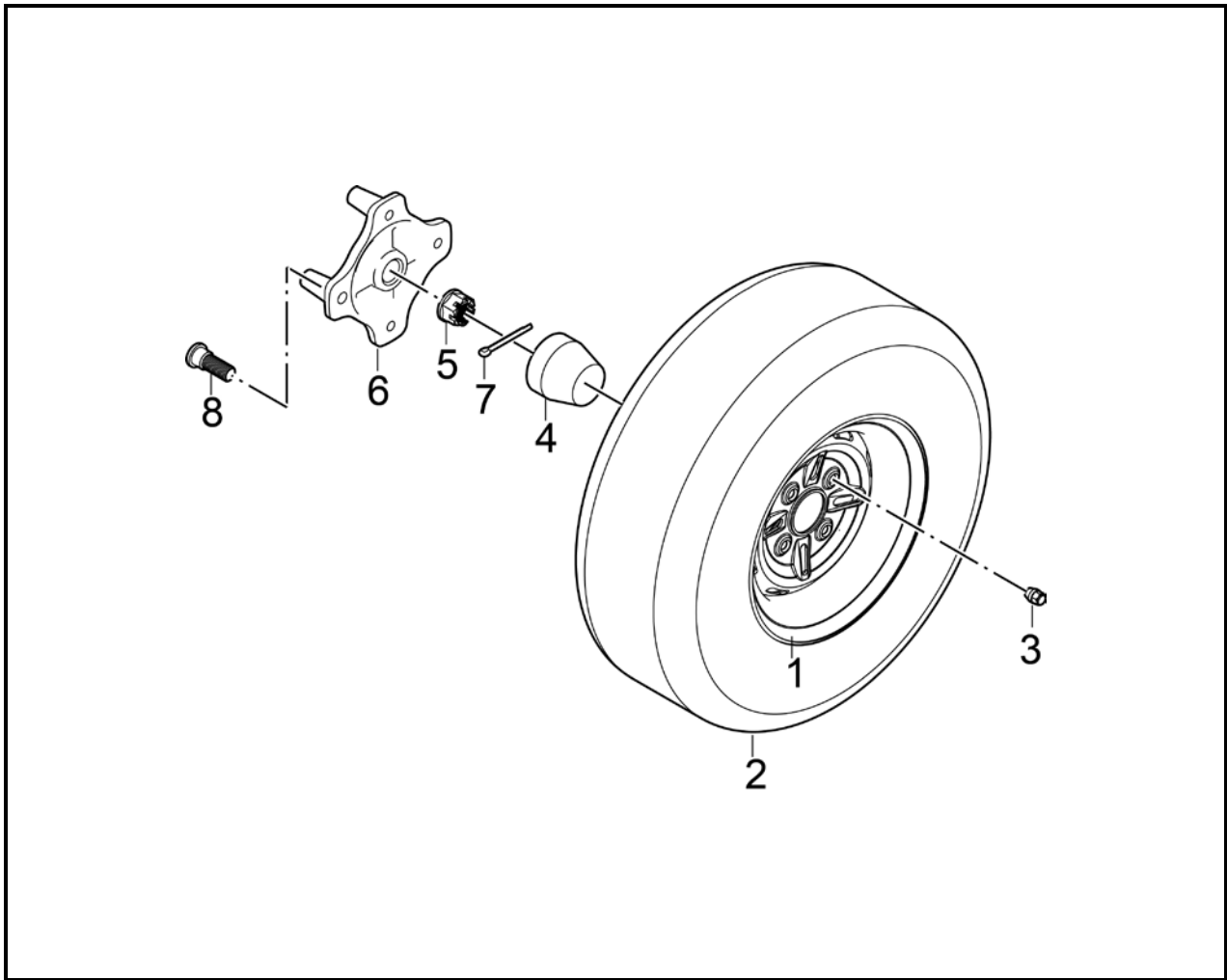

No.	Part Name	Qty	Remarks
	<b>Removing the front wheel</b>		
1	Front rim	2	
2	Front tyre	2	
3	Nut M10	8	
4	Wheel decoration cover IV	2	
5	Nut M22×1.5	2	
6	Front hub	2	
7	Cotter pin 3.2×50	2	
8	Bolt M10×30	4	

**WARNING:**

**Securely support the vehicle so  
There is no danger of it falling over.**

# CHASSIS

## REAR WHEELS

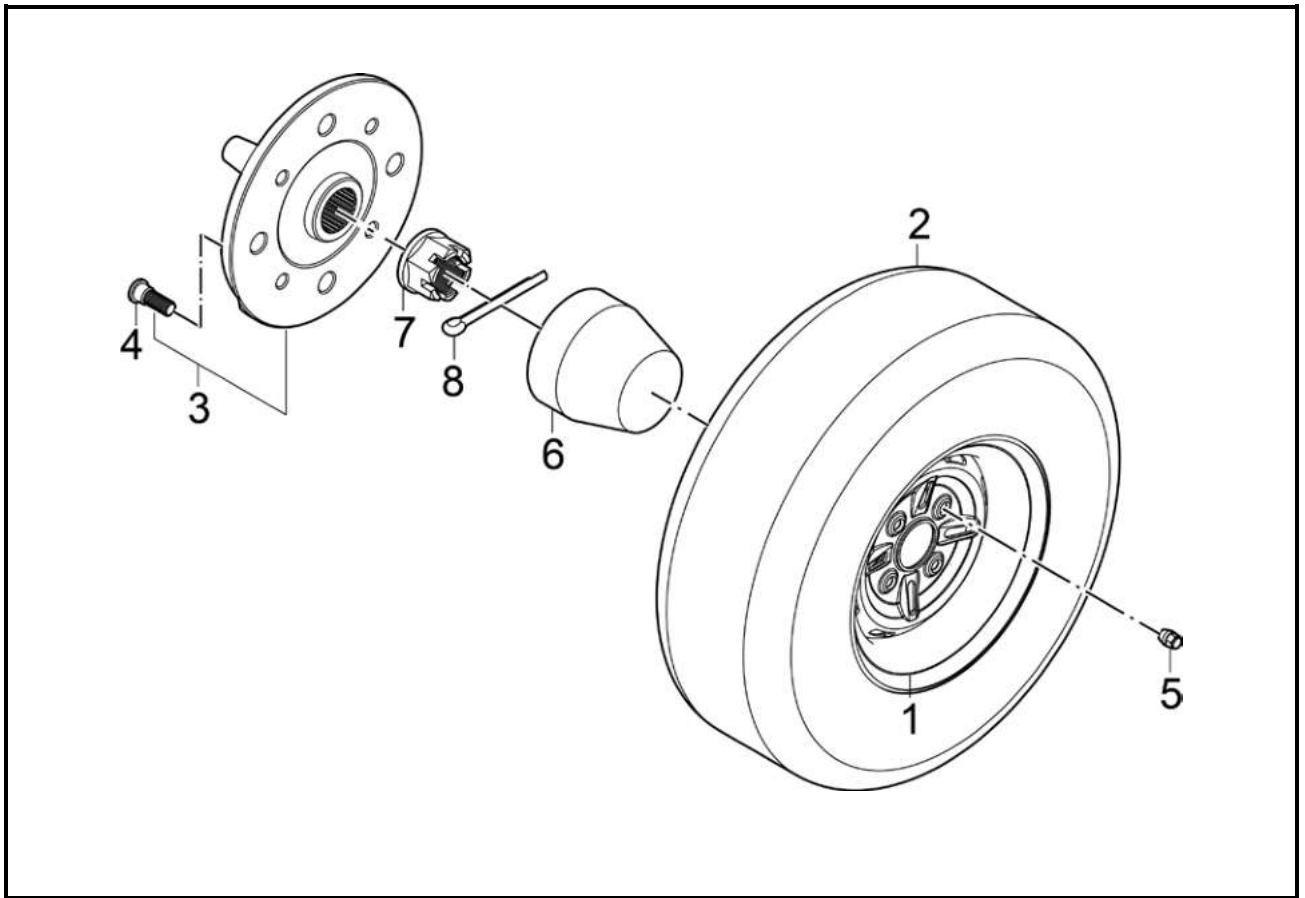

No.	Part Name	Qty	Remarks
	<b>Removing the rear wheel</b>		
1	Rear rim	2	
2	Rear tyre	2	
3	Rear hub	2	
4	Bolt M10×30	4	
5	Nut M10	8	
6	Wheel decoration cover IV	2	
7	Nut M22×1.5	2	
8	Cotter pin 3.2×50	2	
			<b>WARNING:</b> <i>Securely support the vehicle so There is no danger of it falling over.</i>

# CHASSIS

## CHECKING THE WHEEL TYRE

1. Check:

- wheel tyre

2. Measure:

- wheel runout

Over the specified limit → Replace the wheel or check the wheel bearing play ①.

3. Check:

- wheel balance

Out of balance → Adjust.

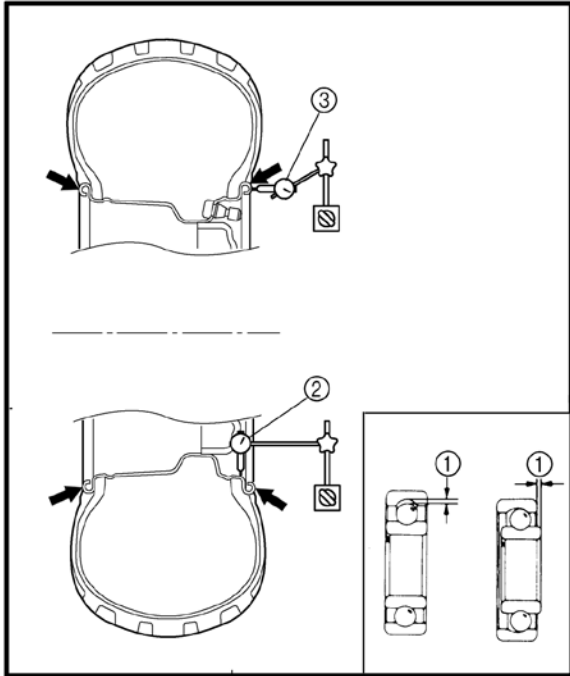

**Wheel runout limit**  
**Radial ②: 2.0 mm (0.08 in)**  
**Lateral ③: 2.0 mm (0.08 in)**

## **WARNING:**

*The profile depth falls below 3mm, Please replace the tyre immediately.*

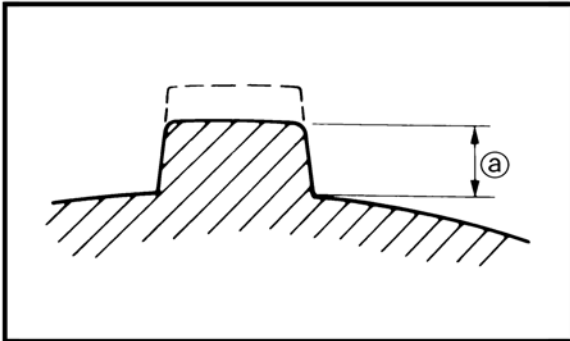

- tyre wear limit ①

## CHECKING THE WHEEL HUB

1. Check:

- wheel hub ①

Cracks/damage → Replace.

- splines (wheel hub) ②

Wear/damage → Replace.

- nuts (wheel hub)

loosen or distorted → Replace or tighten

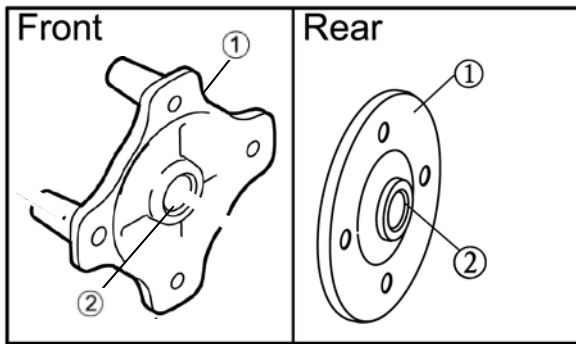

# CHASSIS

## INSTALLING THE WHEEL HUB

1. Install:
  - axle nut

260 Nm (26.0 m · kg, 190 ft · lb)

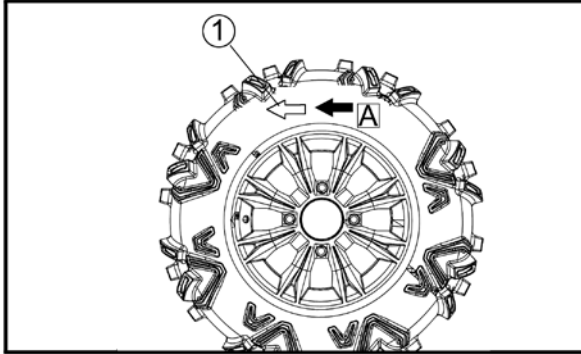

## INSTALLING THE WHEEL TYRE

1. Install:
  - wheel

### NOTE:

The arrow mark ① on the tyre must point in the direction of rotation  $\Delta$  of the wheel.

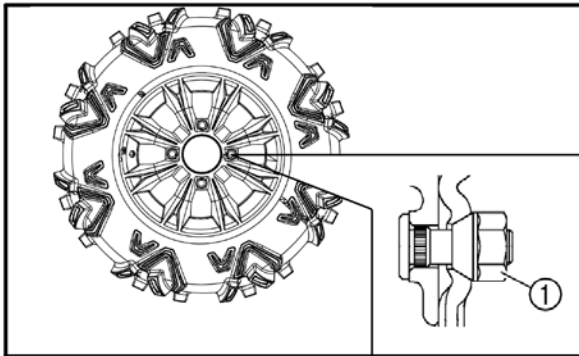

2. Tighten:
  - wheel nuts ①

The angle of the conical bores is 60°

### WARNING:

Tapered wheel nuts ① are used for both the front and rear wheels. Install each nut



## CHASSIS

---

### SPECIFICATION OF WHEEL AND TYRE

	Wheel hub Dimension	Tyre Dimension	Tyre Pressure (Kpa /Psi)
Front Wheel	14×7	26×9-14	100/14
Rear Wheel	14×9	26×11-14	100/14

- Since wheels and tyres are crucial to the vehicle operation, inspection for tyre pressure and profile depth is necessary.
- To ensure maximum security and longer life expectancy of the wheel, please periodically inspect the tyre pressure and profile depth. Insufficient tyre pressure can result in not only intensified wearing of the tyre but also instability during the course of operating the vehicle (such as hard turning). Excessive tyre pressure can also reduce the friction force between the tyre and ground, causing spinning or lose of control. Therefore, please ensure the tyre pressure strictly complies with figures shown in the chart above.
- Before operating the vehicle each time, please check if profile depth of the tyre is over worn, which might result in spinning, instability, lose of control and other potential security risk of the vehicle.

# CHASSIS

## TRANSMISSION SYSTEM

### C.V Axle, Front Axle

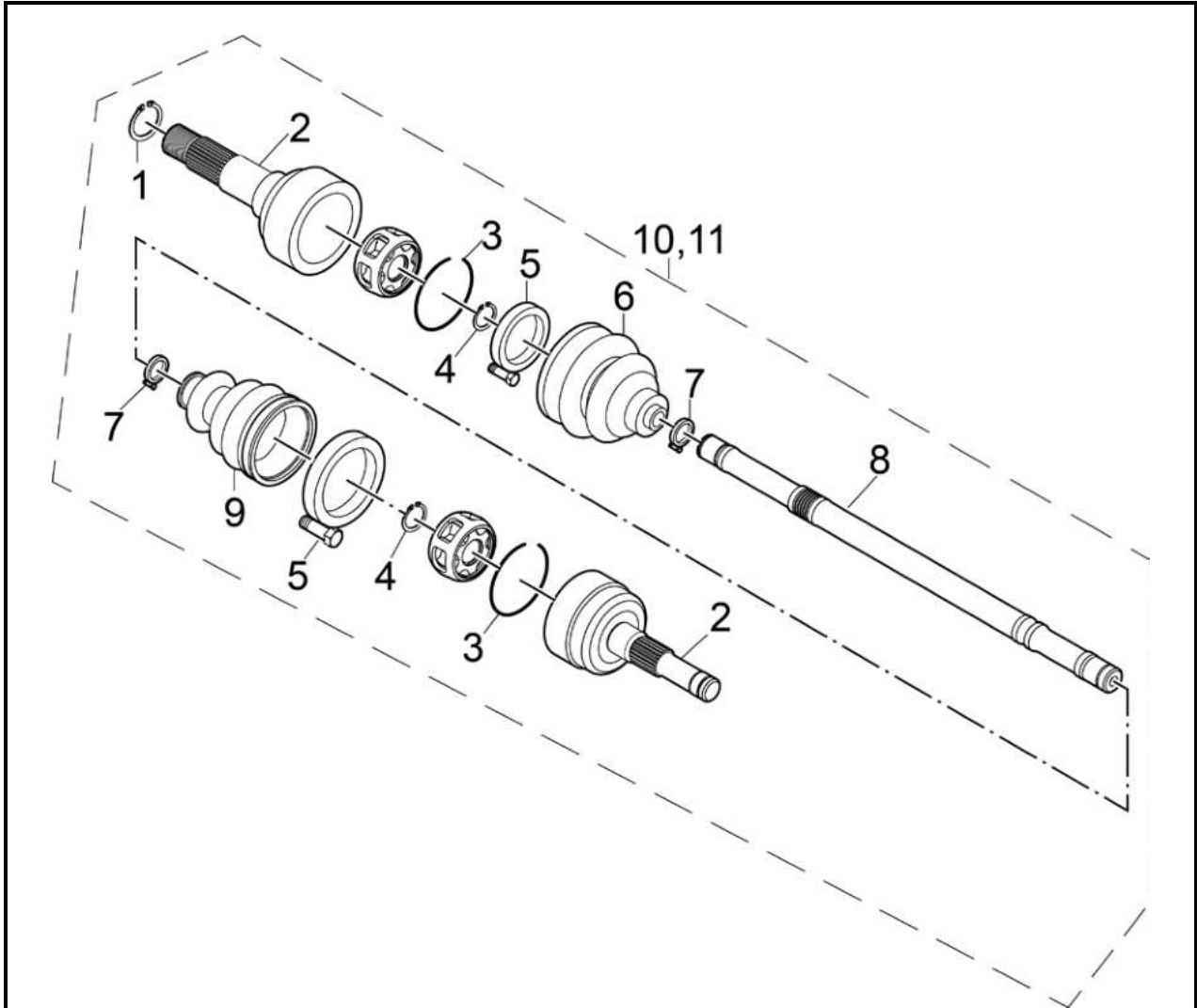

No.	Part Name	Qty	Remarks
1	Circlip	1	
2	Double off-set joint assembly	2	
3	Circlip	2	
4	Circlip	2	
5	Hoop A, dust P shed $\Phi 80$	4	
6	Outer rubber dust-P cover (C-1610)	2	
7	Hoop B, dust P shed $\Phi 32$	4	
8	Joint shaft	1	
9	Inner rubber dust-p cover (C-1605)	2	
10	Front left C.V axle	1	
11	Front right C.V axle	1	

# CHASSIS

## Front Bridge

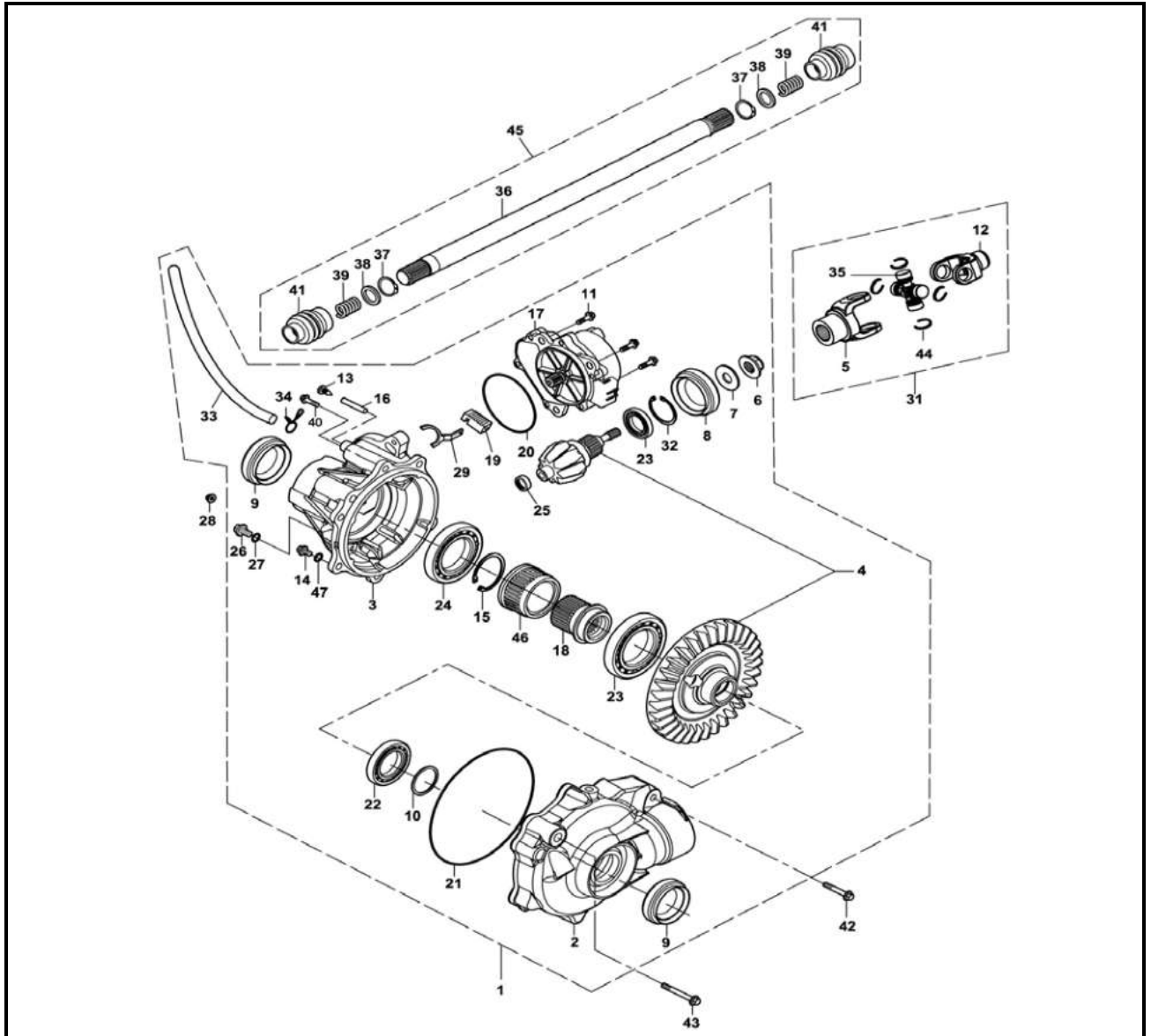

No.	Part Name	Qty	Remarks
	<b>Removing the front bridge</b>		
1	Front differential assy	1	
2	Front differential case II	1	
3	Front differential case I	1	
4	Drive & driven gears assy(with rear differential status)	1	
5	Connection fork I	1	
6	Hexagon flange nut m14×1.5	1	
7	O-type ring Φ6.8×Φ14	1	
8	Oil seal Φ48×Φ65×9	1	
9	Oil seal Φ24×Φ38×8	2	
10	Washer I Φ50×Φ61.5	1	

# CHASSIS

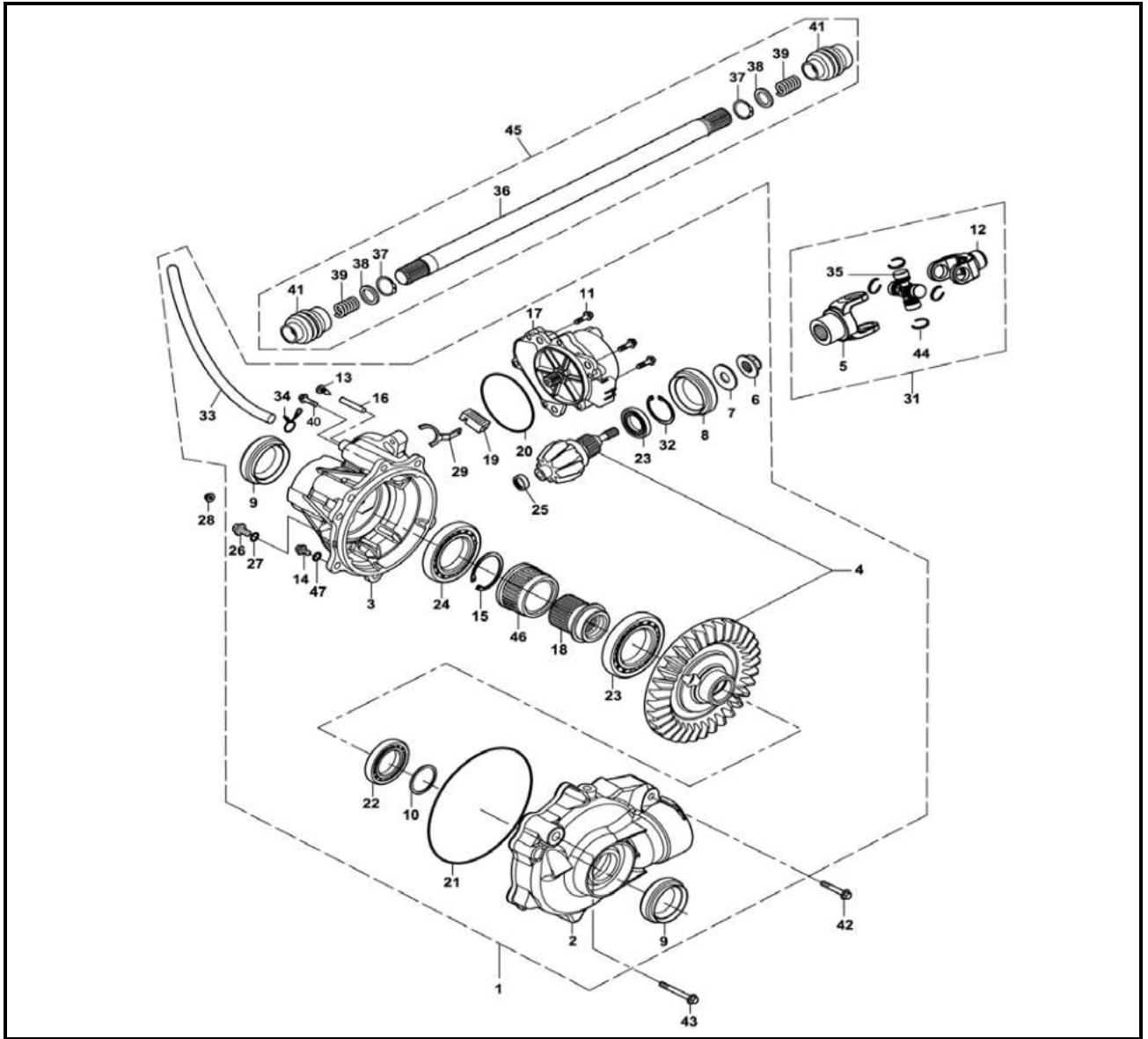

No.	Part Name	Qty	Remarks
11	Socket hexagon screw M8×25	2	
12	Connection fork II	1	
13	Socket hexagon screw M8×10	1	
14	Hexagon flange bolt M10×1.25×15	1	
15	Clip D0=62	1	
16	Pin Φ5×75	1	
17	Transfer case assembly	1	
18	Divide device connection	1	
19	Rack	1	
20	O-ring Φ2×Φ81,transfer case	1	
21	O-ring Φ2.62×Φ139.37, front tank cover	1	

# CHASSIS

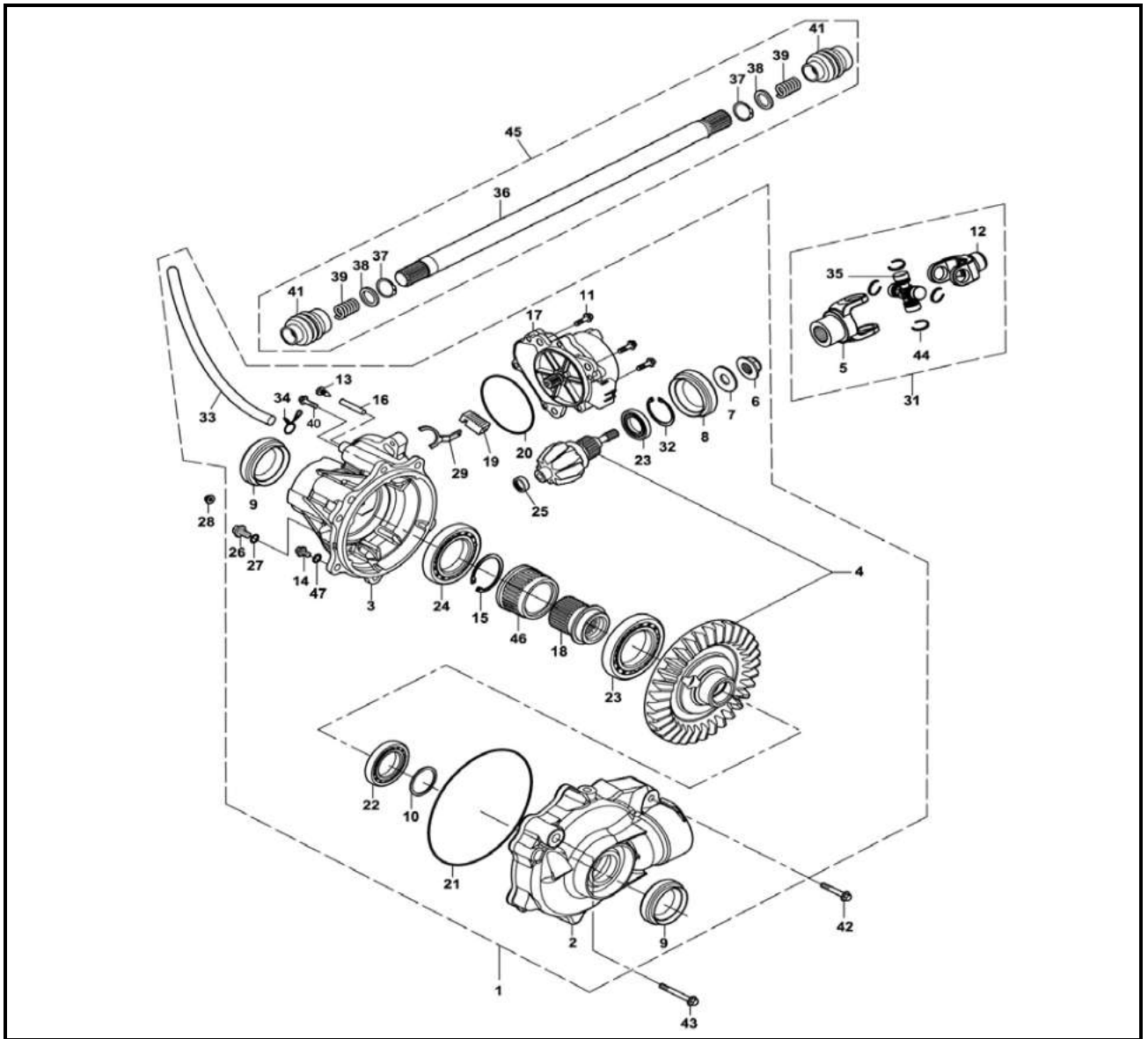

No.	Part Name	Qty	Remarks
22	Bearing $\Phi 35 \times \Phi 62 \times 14$	1	
23	Bearing $\Phi 60 \times \Phi 85 \times 13$	1	
24	Bearing $\Phi 35 \times \Phi 62 \times 9$	1	
25	Rolling bearing $\Phi 15 \times \Phi 21 \times 12$	1	
26	Screw	1	
27	Copper washer $\Phi 13 \times 1.5$	1	
28	Hexagon flange nut M10 $\times$ 1.25	1	
29	Shaft fork IV	6	
30	Clamp $\Phi 20$ -32	1	
31	Universal joint I	1	
32	Clip D0=62	1	
33	Vent pipe l=700	1	

# CHASSIS

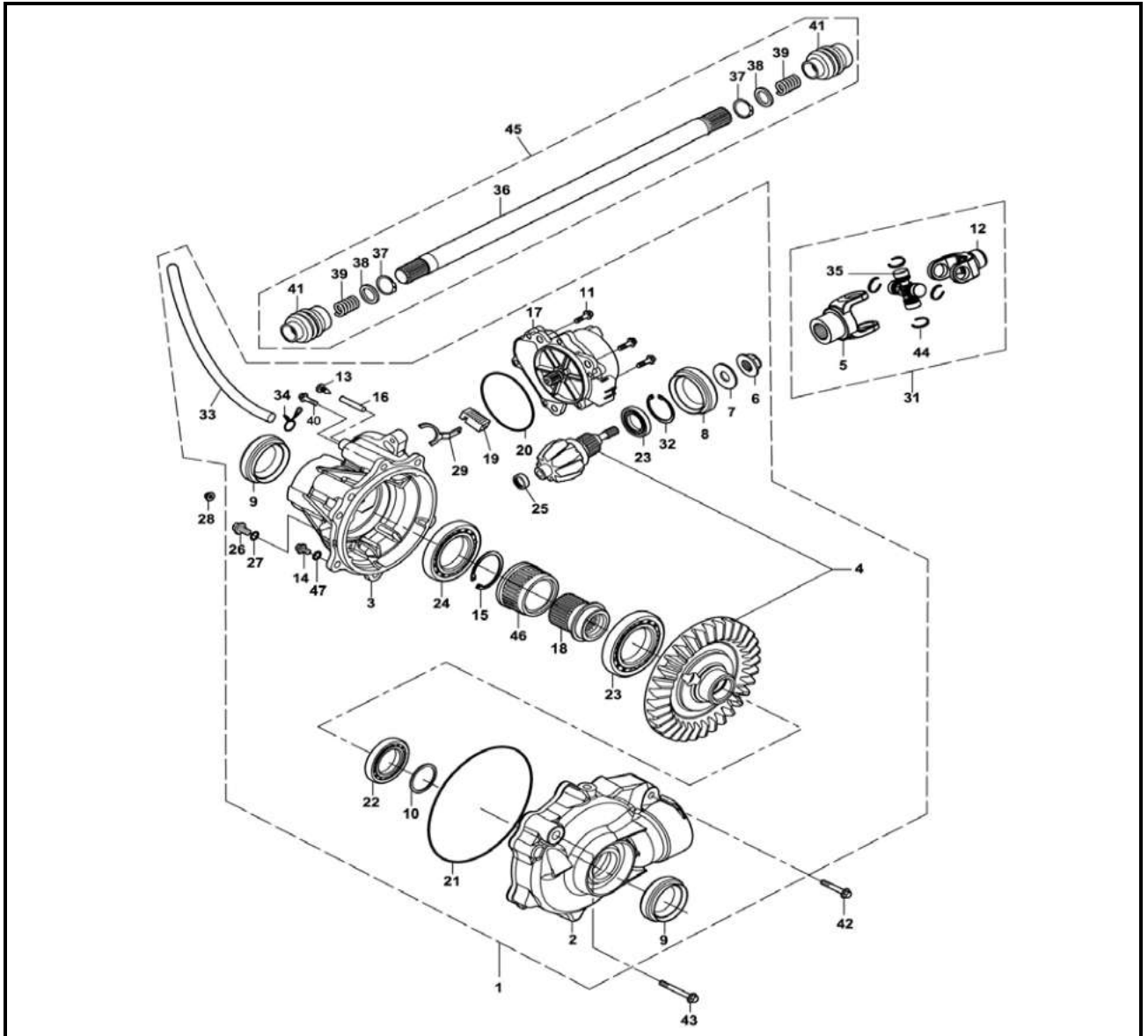

No.	Part Name	Qty	Remarks
34	Oil pipe clip $\Phi 8$	1	
35	Cross shaft ( $\Phi 20$ )	1	
36	Front transmission shaft	1	
37	Circlip $D0=19$	2	
38	Circlip $\Phi 20 \times \Phi 26 \times 1$	2	
39	Spring $\Phi 25 \times \Phi 2.3 \times 28$	2	
40	Hexagon flange bolt $M8 \times 28$	6	
41	Front dustproof rubber cover $\Phi 19 \times \Phi 38 \times 50$ , front transmission shaft	2	
42	Hexagon flange bolt $M10 \times 1.25 \times 30$	2	
43	Hexagon flange bolt $M10 \times 1.25 \times 142$	1	
44	Block ring	4	

# CHASSIS

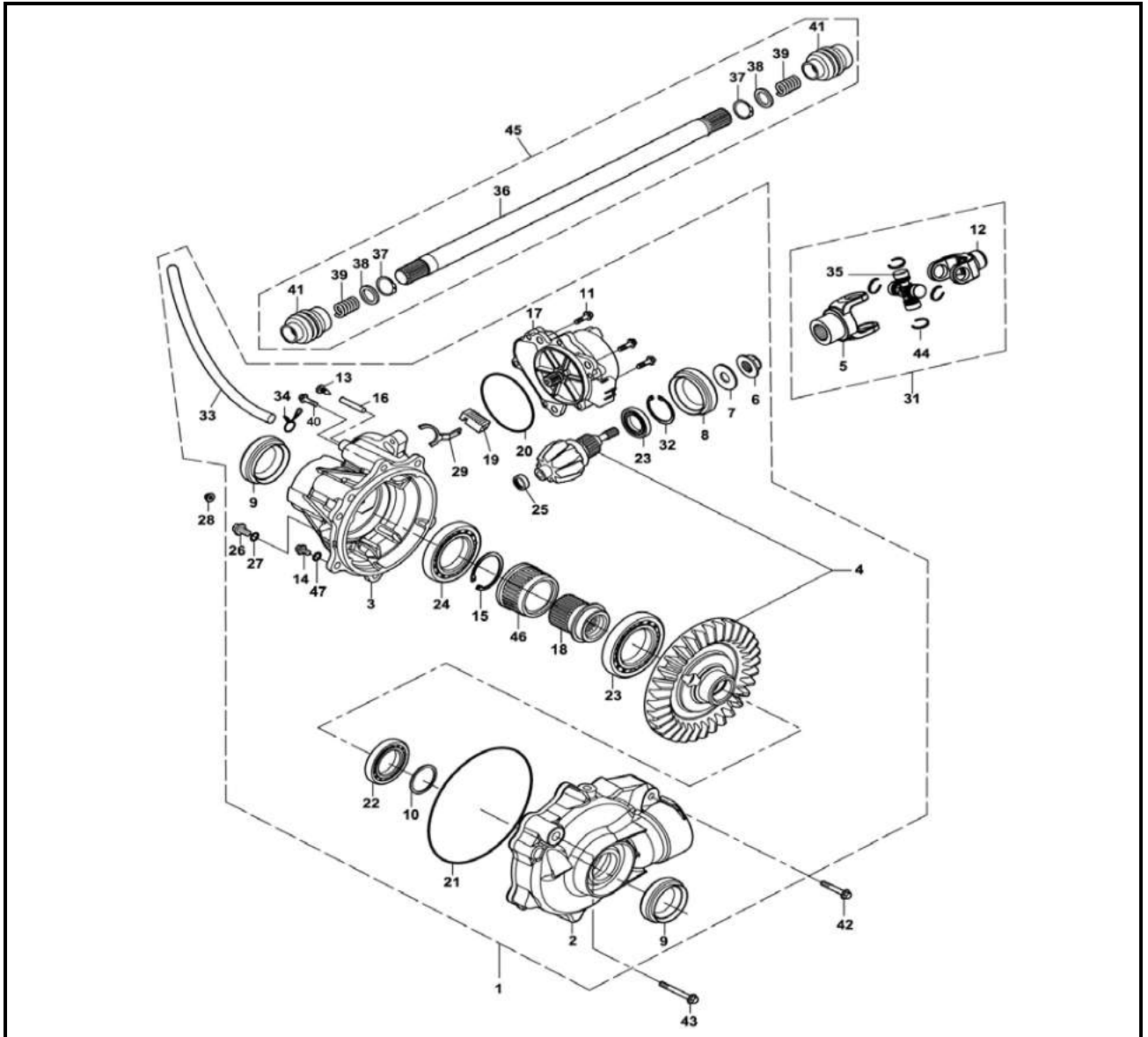

No.	Part Name	Qty	Remarks
45	Front transmission shaft comp	1	
46	Sliding sleeve	1	
47	O-ring 1.5×9	1	

# CHASSIS

## Front Bridge

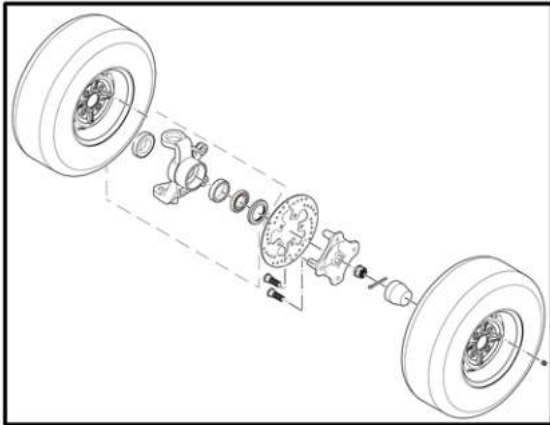



### DISASSEMBLING THE FRONT BRIDGE

1. Take down the left and right front wheel parts.
2. Sequentially remove the front disk brake clip, cotter pin, open-groove nut, cushion and front wheel hub.
3. Disassembly the left and right arm rocker and cross steering knuckle.
4. Disassembly the differential device
5. Take down the front bridge from the frame
6. Emit the oil in the differential device
7. Pull out the left and right transmission shaft from the differential device.

### DISASSEMBLING THE UNIVERSAL JOINT

Remove:

- universal joint

- a. Remove the circlips ①.
- b. Place the universal joint in a press.
- c. With a suitable diameter pipe  at the yoke  ③, press shown.
- d. Repeat the steps for the opposite bearing.
- e. remove the yoke.

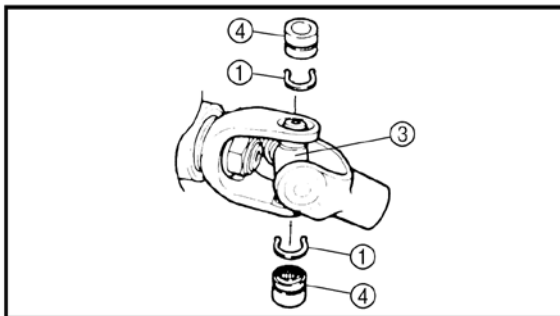
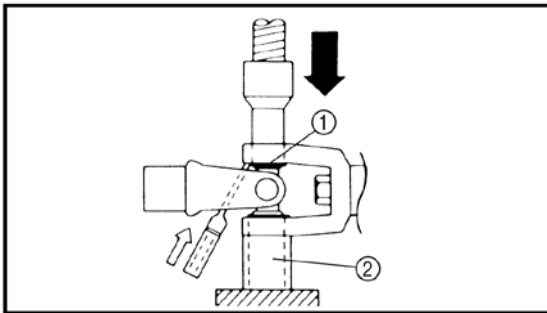

### NOTE:

It may be necessary to lightly tap the yoke with a punch.



## CHASSIS

---

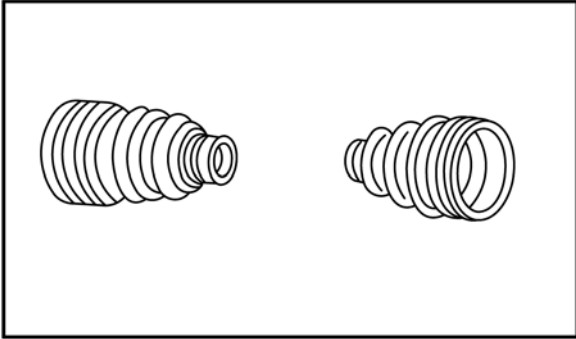

### CHECKING THE C.V AXLE, FRONT AXLE

#### 1.Check:

- Rubber dust-P cover
- Cracks/damage → Replace

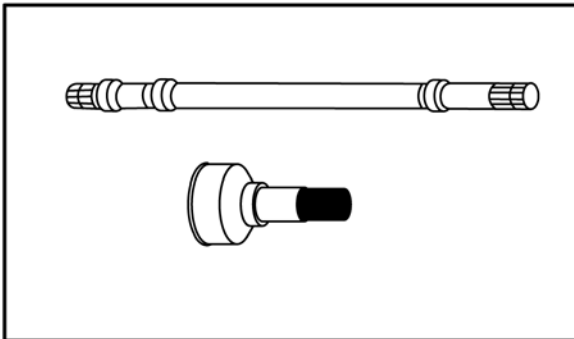

#### 2.Check:

- double off-set assembly
  - ball joint spline
  - shaft spline
- Wear/damage → Replace.
- balls and ball races
  - inner surface of double off-set
- Pitting/wear/damage → Replace.
- Check whether the inner and outer ball cage of the left and right transmission shaft movement is Smooth, ceaseless. If it is stagnation and obvious becoming less loosen, replace it.
  - Disassemble the left and right transmission shaft ,cleaning and assemble it again.

#### **NOTE:**

1. The dustproof rubber wrap on the ball cage is not allow to contact with the gas and diesel oil.
  2. The dustproof rubber wrap does not allow to be scratched, a slight scratches can damage the dustproof rubber wrap very quickly.
  3. When reassembles the left and right transmission shaft, in the ball cage must sufficiently enter 2/3 volume with the Lithium lubricating.
-

## CHASSIS

---

### ASSEMBLING THE UNIVERSAL JOINT

Install:

- universal joint
- a. Install the opposite yoke into the universal joint.
- b. Apply wheel bearing grease to the bearings.
- c. Install the bearing ① onto the yoke.
- d. Press each bearing into the universal joint using a suitable socket.

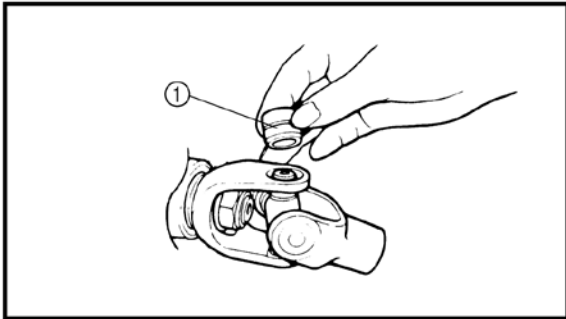
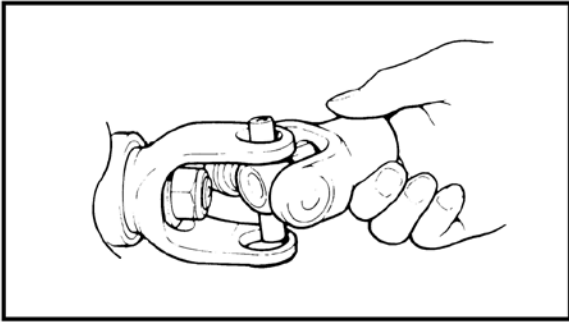

---

**CAUTION:**

Check each bearing. The needles can easily fall out of their races. Slide the yoke back and forth on the bearings; the yoke will not go all the way onto a bearing if a needle is out of plate.

---

**NOTE:**

The bearing must be inserted far enough into the universal joint so that the circlip can be installed.

---

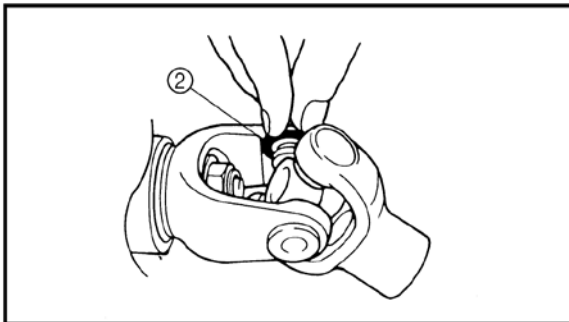

- e. Install the circlips ② into the groove of each bearing.

# CHASSIS

## C.V Axle, Rear Axle

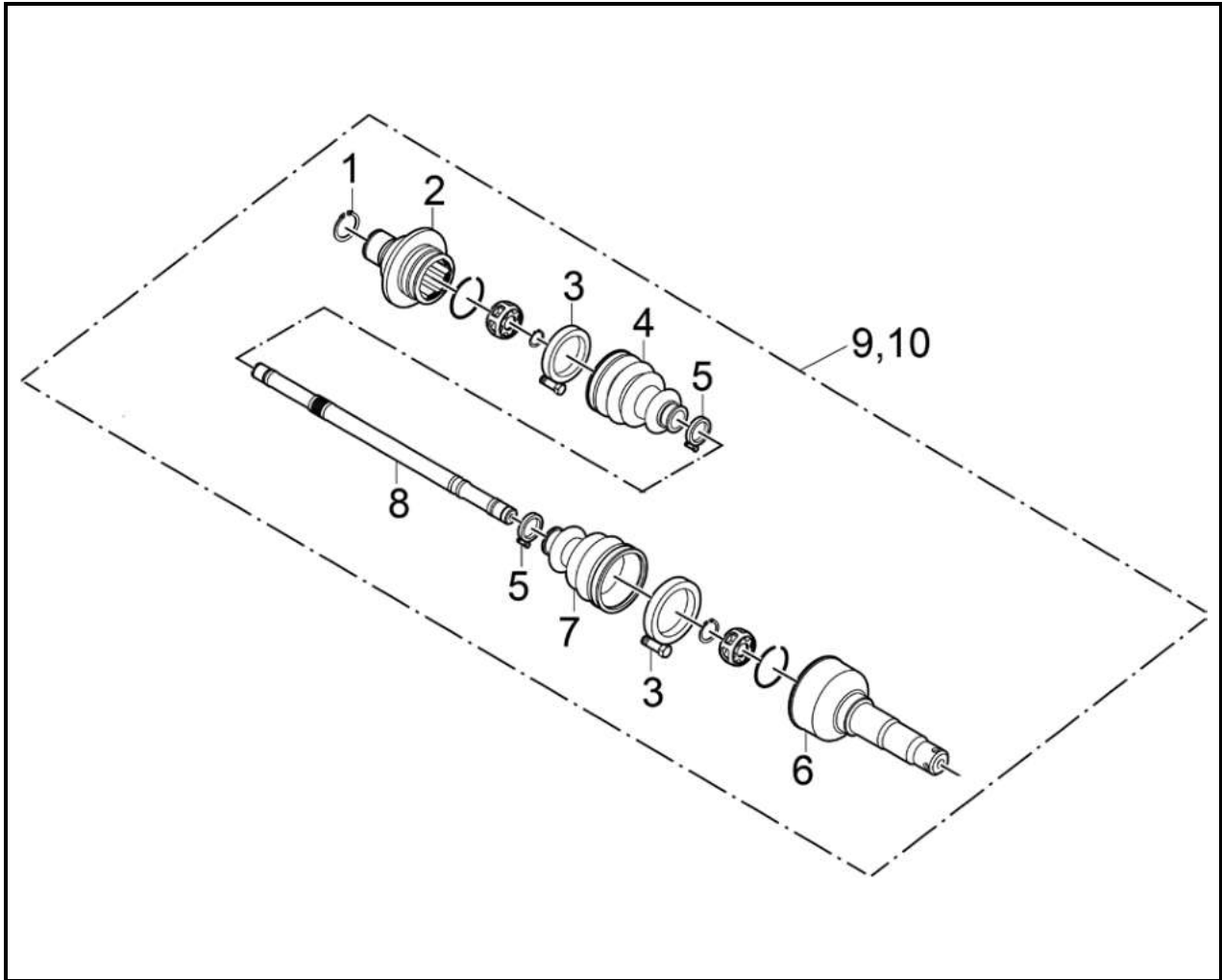

No.	Part Name	Qty	Remarks
	<b>Removing the rear axle</b>		
1	Circlip	2	
2	Double off-set joint assembly	2	
3	Hoop A, dust P shed Φ80	4	
4	Inner rubber dust-P cover (C-1520)	2	
5	Hoop B, dust P shed Φ32	4	
6	Double off-set joint assembly	2	
7	Inner rubber dust-P cover (C-1605)	2	
8	Half axle assembly	2	
9	Rear left C.V axle	1	
10	Rear right C.V axle	1	
11	Circlip	2	
12	Double off-set joint assembly	2	

# CHASSIS

## Rear Bridge Reducer

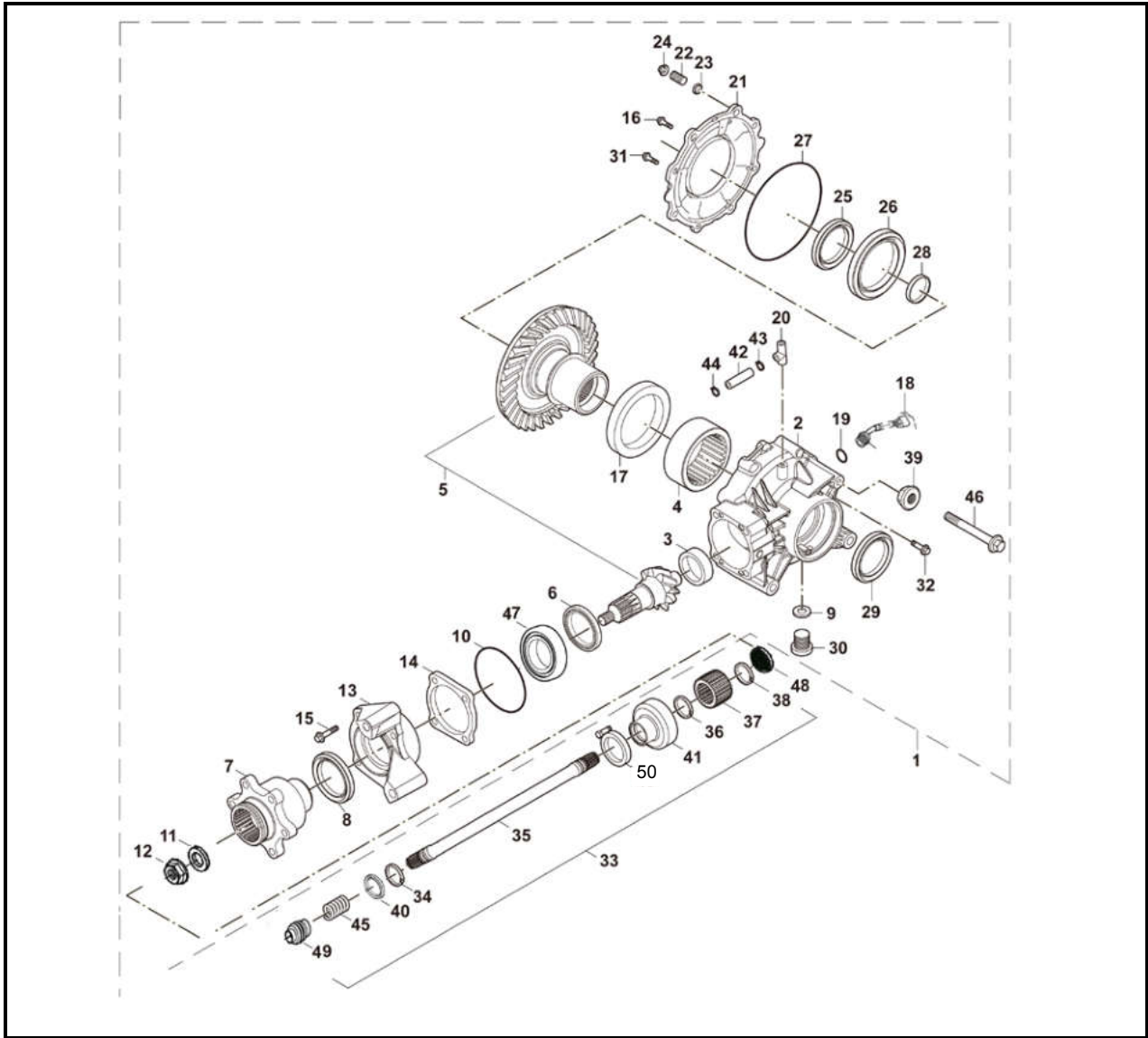

No.	Part Name	Qty	Remarks
	<b>Removing the rear bridge</b>		
1	Rear reducer assy	1	
2	Rear reducer case I	1	
3	Bearing $\Phi 22 \times \Phi 30 \times 13$	1	
4	Bearing 55bM6720 $\Phi 55 \times \Phi 67 \times 20$	1	
5	Drive & driven gears	1	
6	Bearing $\Phi 25 \times \Phi 62 \times 17$	1	
7	Mount bracket, rear disk brake plate	1	
8	Oil seal $\Phi 61 \times \Phi 35 \times 9$	1	
9	Fuel drain o-ring seal $\Phi 13 \times \Phi 1.5$	1	
10	O-ring gasket $\Phi 3 \times \Phi 71$	1	

## CHASSIS

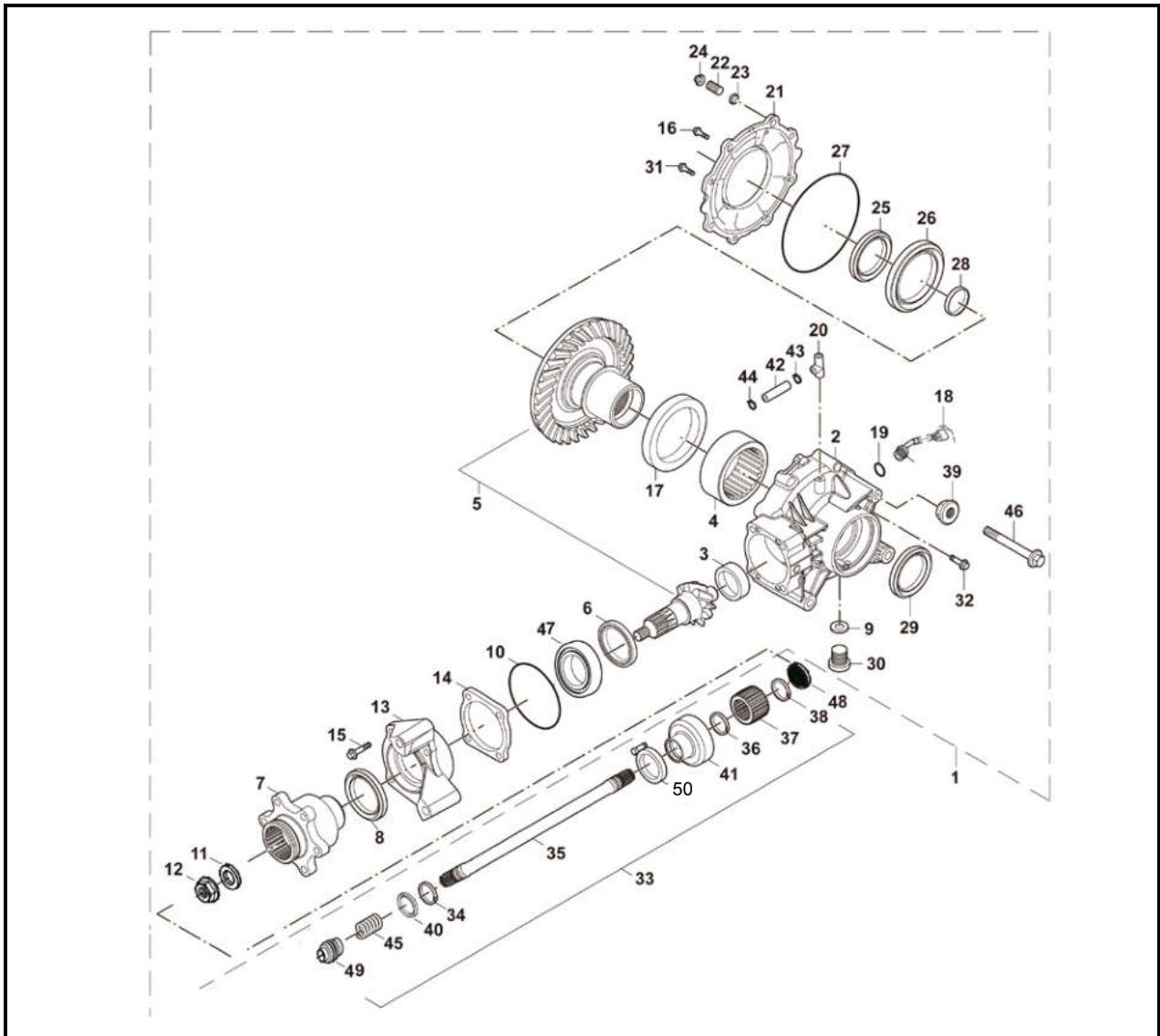

No.	Part Name	Qty	Remarks
11	Washer $\Phi 12 \times \Phi 30 \times 4$	1	
12	Hexagon flange nut M12 $\times$ 1.25	1	
13	Mount bracket, rear brake caliper	1	
14	Rear adjustment gasket I	1	
15	Hexagon bolt with washer	4	
16	Socket hexagon screw M8 $\times$ 25	1	
17	Rear adjustment gasket II	1	
18	Speed sensor comp.	1	
19	O-ring gasket, fuel injection $\Phi 2.3 \times \Phi 19.4$	1	
20	Vent pipe, rear reducer	1	
21	Rear reducer case II	1	
22	Socket hexagon screw M8 $\times$ 45	1	
23	Washer $\Phi 8.2 \times 1$	4	

# CHASSIS

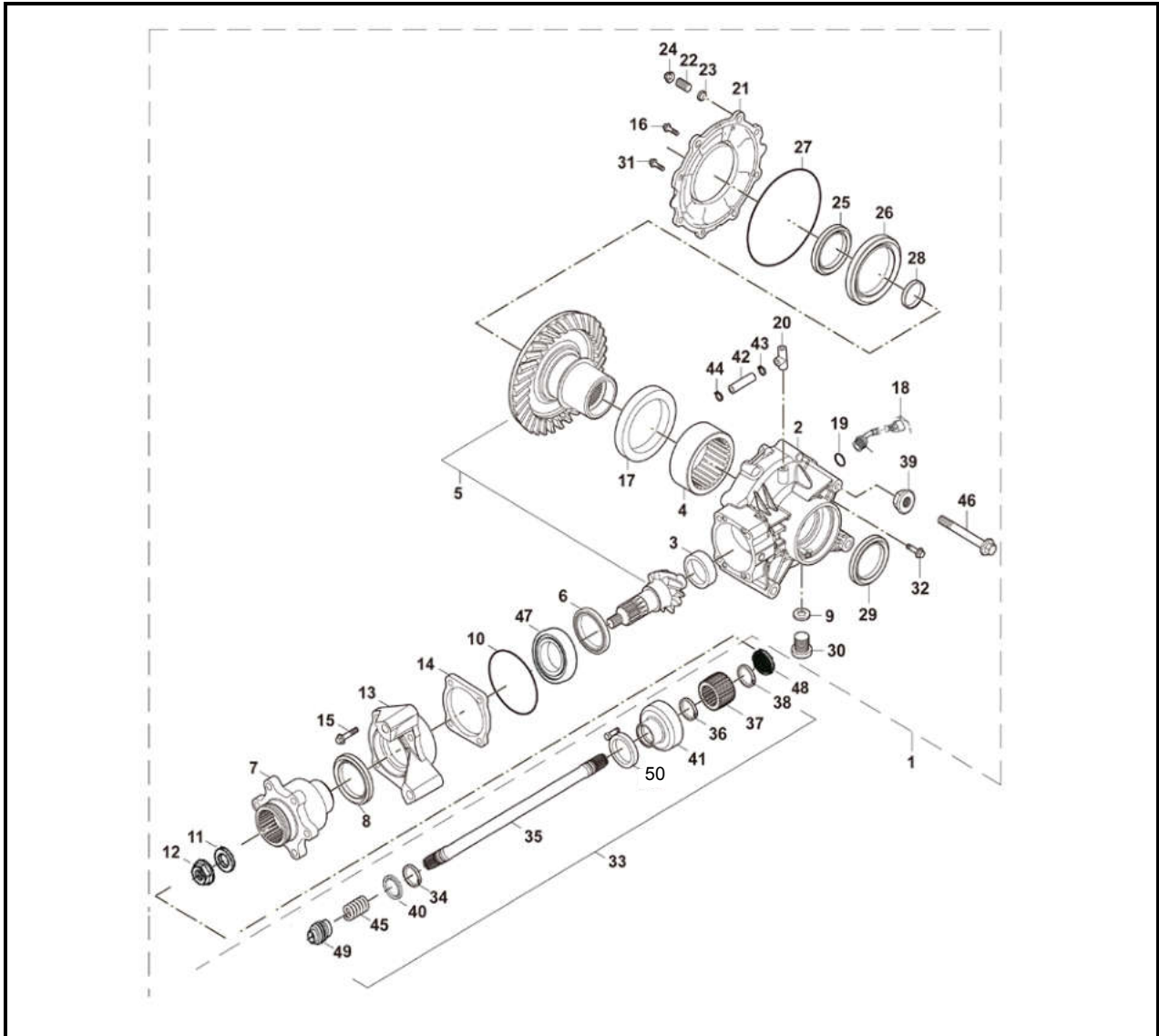

No.	Part Name	Qty	Remarks
24	Hexagon flange nut M8	2	
25	Oil seal $\Phi 65 \times \Phi 90 \times 9$	1	
26	Bearing 16017C2 $\Phi 85 \times \Phi 130 \times 14$	1	
27	O-ring $\Phi 3 \times \Phi 150$	2	
28	Adjustment gasket III	1	
29	Oil Seal $\Phi 65 \times \Phi 90 \times 9$	1	
30	Fuel drain screw plug	1	
31	Hexagon flange nut M10 $\times$ 1.25 $\times$ 25	1	
32	Hexagon flange bolt M8 $\times$ 12	4	
33	Rear transmission shaft comp	1	
34	Circlip D0=19	1	
35	Rear transmission shaft	1	

## CHASSIS

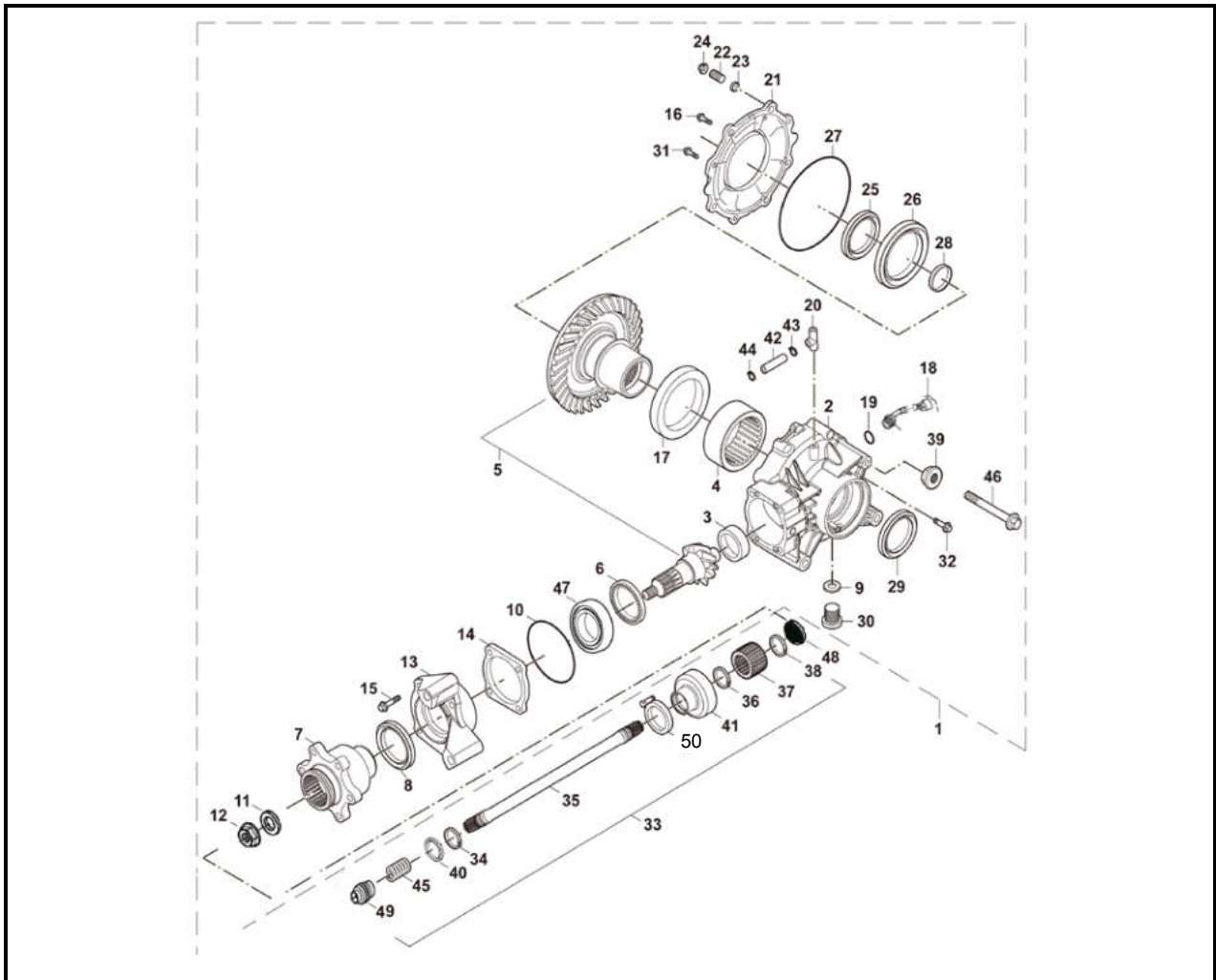

No.	Part Name	Qty	Remarks
36	Circlip D0=19	2	
37	Joint sleeve, rear axle transmission shaft	1	
38	Elasticity block ring D0=22	1	
39	Hexagon flange nut M10×1.25	2	
40	Circlip Φ20×Φ26×1	1	
41	Rear dust cover Φ20.5×Φ48×30,	1	
42	Vent pipe, rear reducer	1	
43	Steel Wire Clamp Φ8	1	
44	Clip Φ11	1	
45	Spring Φ25×Φ2.3×28	1	
46	Hexagon flange bolt M10×1.25×120	2	
47	Impaction ring	1	
48	Rubber washer of shaft	1	
49	Front dustproof rubber cover Φ19×Φ38×50, front transmission shaft	1	
50	Clamp Φ20-32	1	

## CHASSIS

---

### Rear Bridge

(The service method of the rear bridge parts is as the same as the front bridge parts, please refer to the before-mentioned to operate.)

**NOTE:**

Apply lithium-soap-based grease to the bearing assembly and o-ring and bearing and driven gear and oil seal and drive shaft coupling and final drive pinion gear bearing housing.



# CHASSIS

## Shift Operating System (Bench seat)

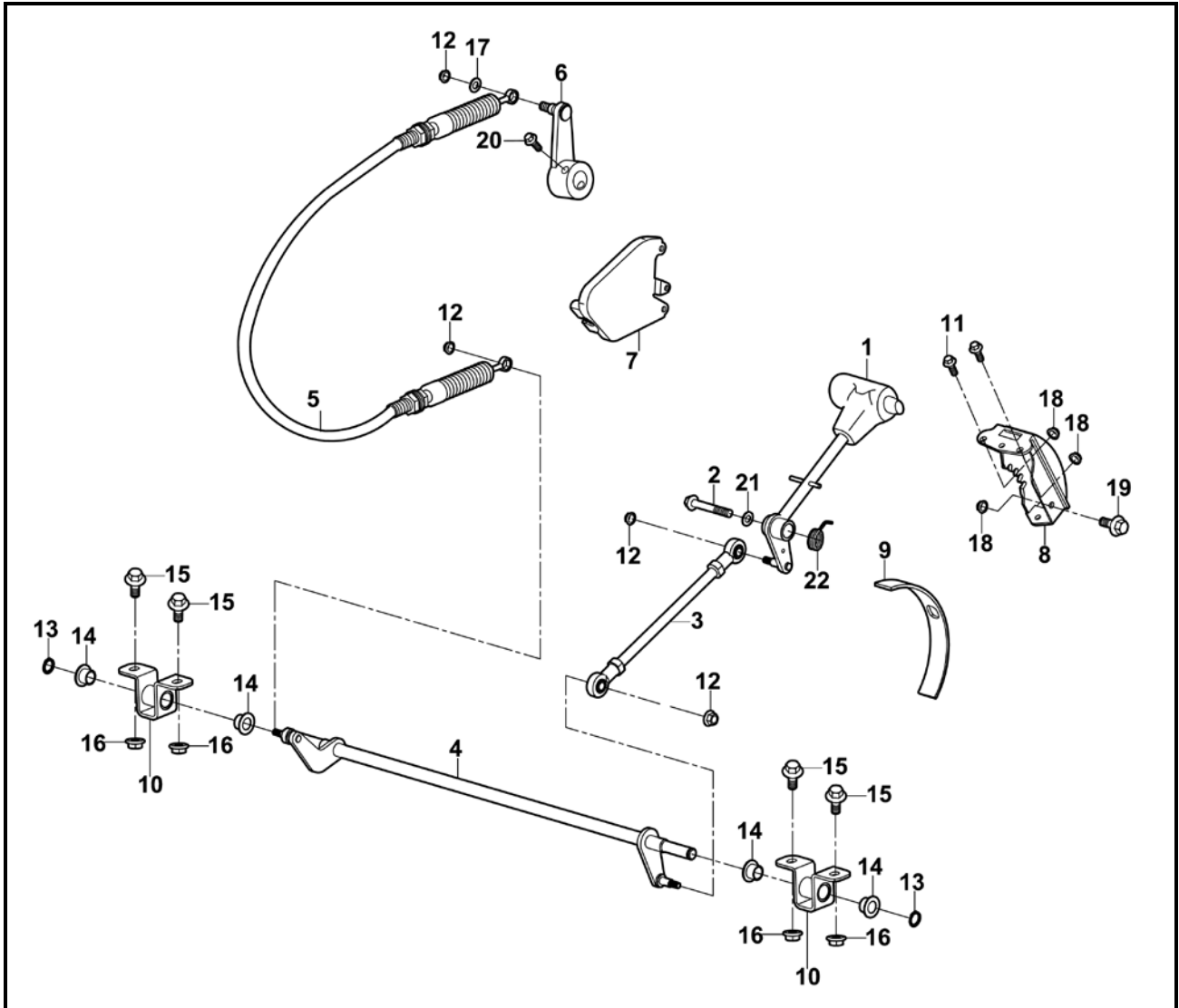

No.	Part Name	Qty	Remarks
	<b>Removing the shift operating system</b>		
1	Gear shifter assembly	1	
2	Hexagon flange bolt M8×25	1	
3	Gear shift rod	1	
4	Shifting arm assy	1	
5	Gearshift cable assy	1	
6	Gearshift arm assy	1	
7	Gearshift cable fix plate	1	
8	Gear shift cover	1	
9	Gearshift cover	1	
10	Shift arm mounting plate	2	
11	Hexagon flange bolt M6×16	2	
12	Hexagon flange self-lock nut M6	4	

# CHASSIS

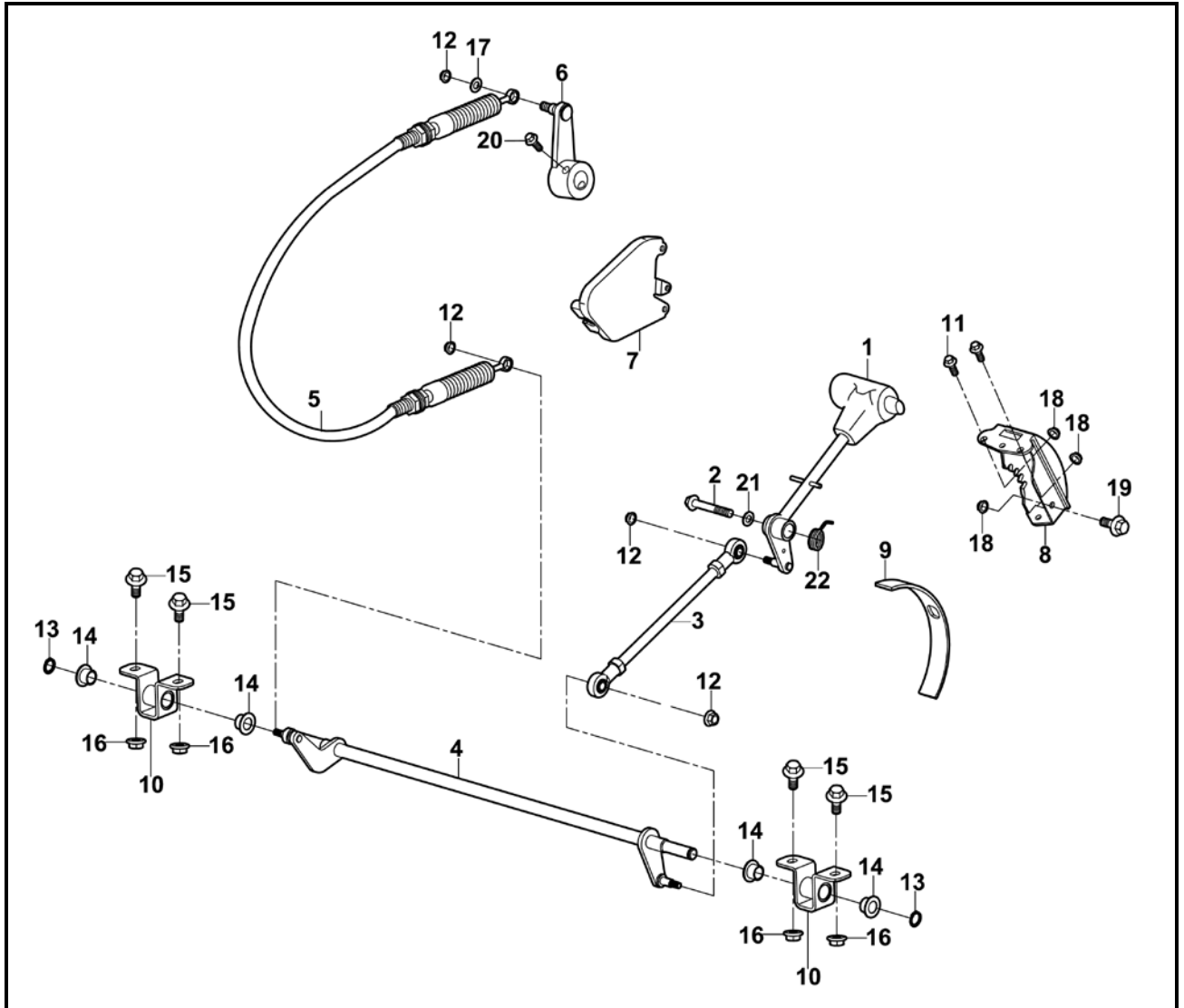

No.	Part Name	Qty	Remarks
13	Split washer 12	2	
14	Rubber washer $\Phi 11 \times \Phi 16 \times \Phi 23 \times 11$	4	
15	Hexagon flange bolt M8×55	4	
16	Hexagon flange self-lock nut M8	4	
17	Washer $\Phi 6 \times \Phi 18 \times 1.6$	1	
18	Hexagon flange nut M6	3	
19	Hexagon flange bolt M8×20	1	
20	Hexagon flange bolt M6×30	1	
21	Cushion $\Phi 8 \times \Phi 24 \times 2$	1	
22	Spring $\Phi 2.5 \times \Phi 23 \times 90^\circ$	1	

# CHASSIS

## Shift Operating System (Bucket seat)

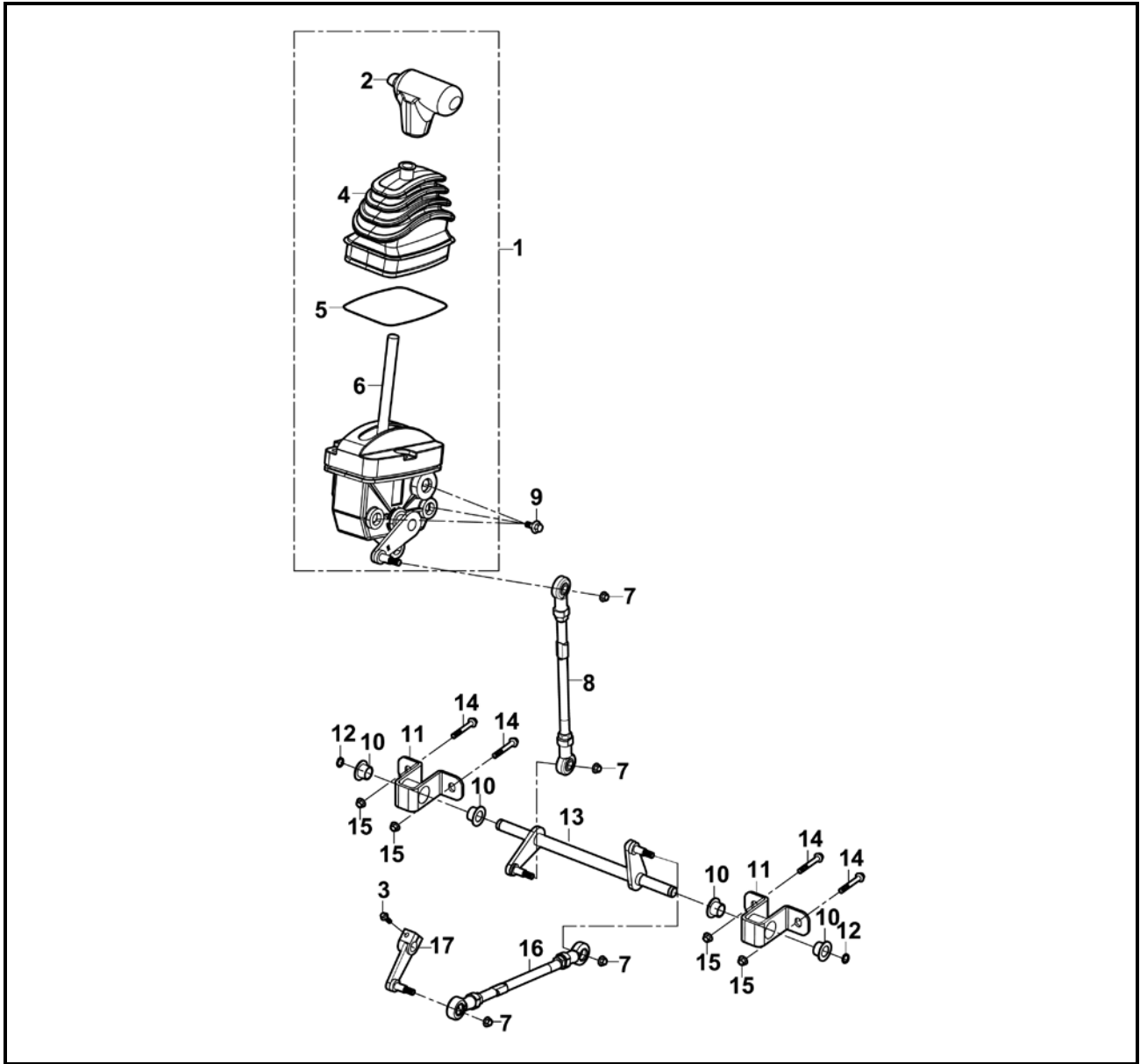

No.	Part Name	Qty	Remarks
	<b>Removing the shift operating system</b>		
1	Gear shifter assembly	1	
2	Gearshift knob	1	
3	Hexagon flange bolt M6×30	1	
4	Gearshift boot	1	
5	Clamp	1	
6	Gearshift assy	1	
7	Hexagon flange bolt M6	4	
8	Gearshift rod	1	
9	Hexagon flange bolt M8×16	3	

# CHASSIS

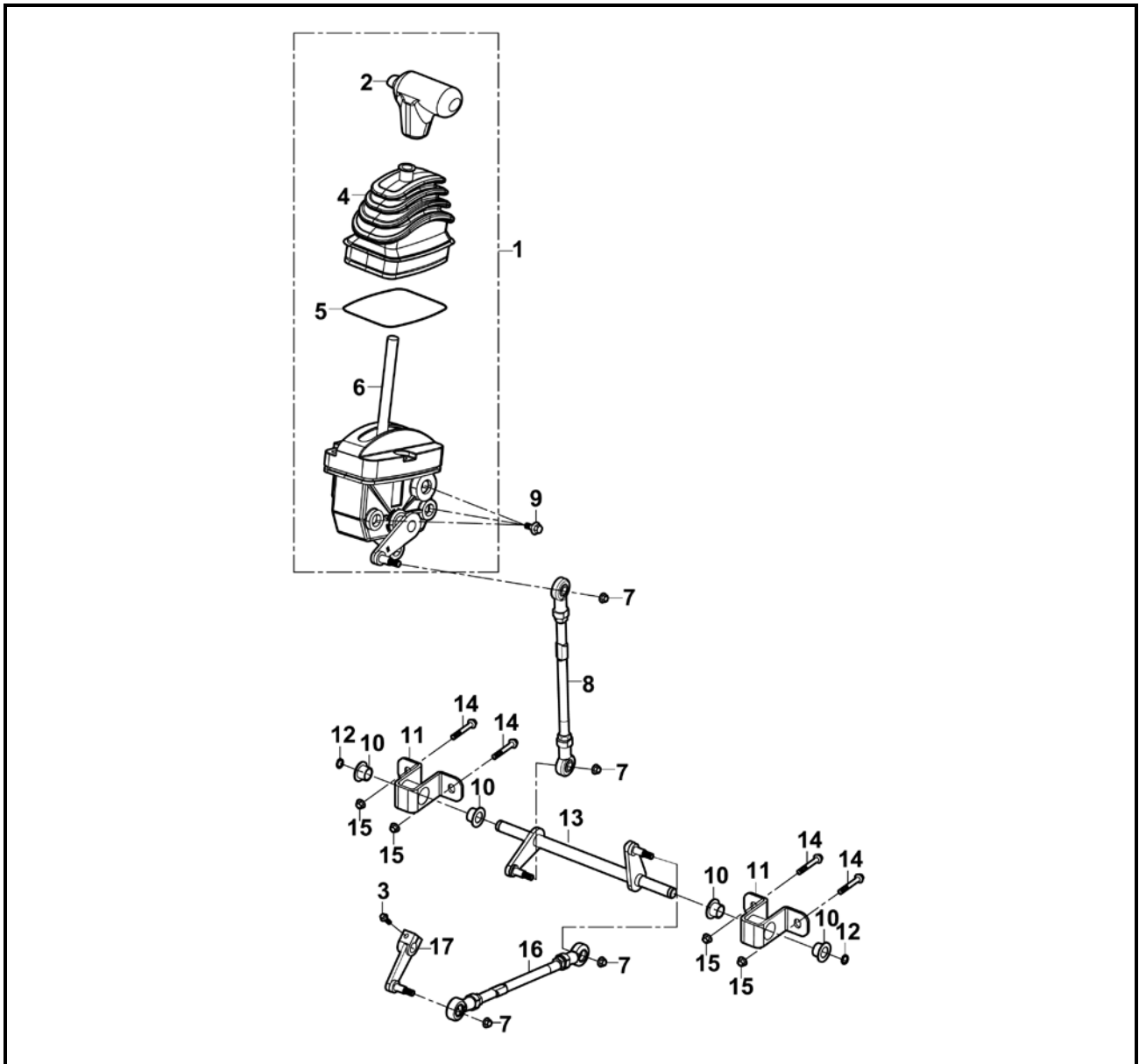

No.	Part Name	Qty	Remarks
10	Nylon collar bushing $\Phi 11 \times \Phi 16 \times \Phi 22 \times 11$	4	
11	Gearshift seat	2	
12	Split washer 12	2	
13	Gearshift assy I	1	
14	Hexagon flange bolt M8×35	4	
15	Hexagon flange lock nut M8	4	
16	Gearshift rod	1	
17	Gearshift arm assy.	1	

## CHASSIS

### Reverse mechanism parts (Bench seat)

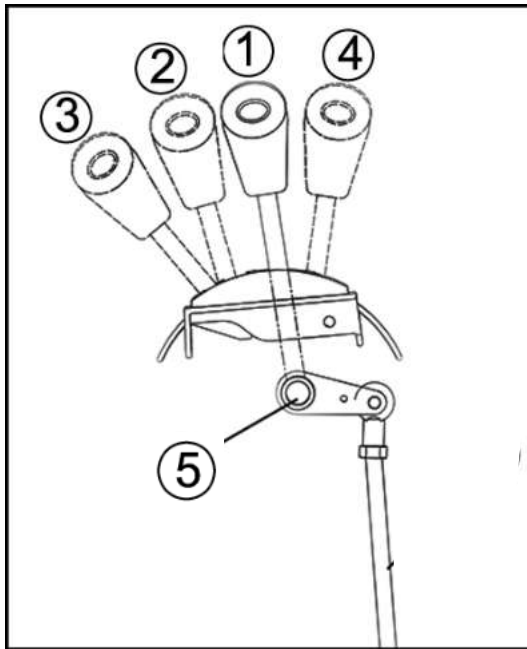

### ADJUSTING REVERSE MECHANISM PARTS

- ① Neutral
- ② High
- ③ Low
- ④ Reverse
- ⑤ Select lever shift rod

#### **NOTE:**

**Before shifting, you must stop the vehicle and take your foot off the accelerator pedal. Otherwise, the transmission may be damaged.**

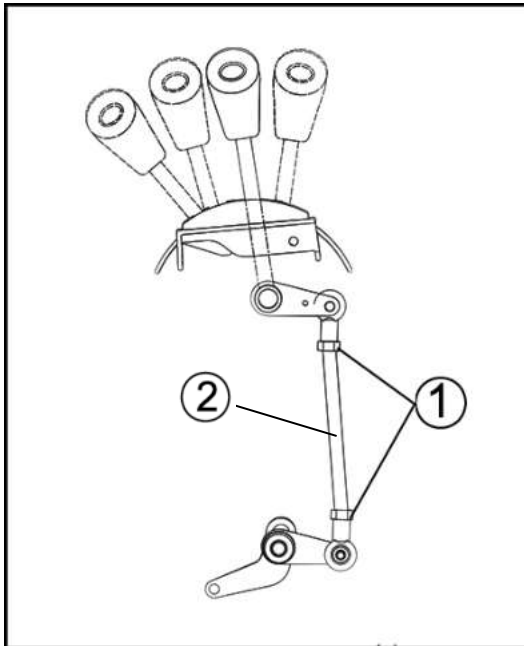

1. Adjust:
  - Select lever shift rod
    - a. Make sure the select lever is in NEUTRAL.
    - b. Loosen both in nuts ①.
    - c. Adjust the shift rod length for smooth and correct shifting ②.
    - d. Tighten the nuts ①.

#### **Nut**

**23 Nm (2.3 m · kg, 17 ft · lb)**

# CHASSIS

## Reverse mechanism parts (Bucket seat)

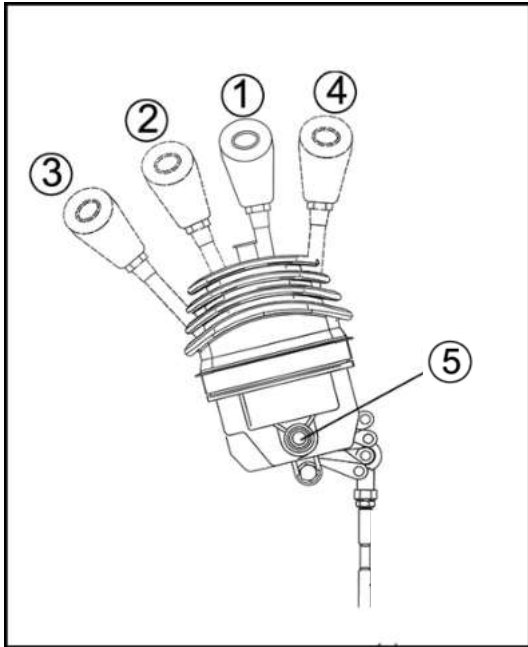

### ADJUSTING REVERSE MECHANISM PARTS

- ① Neutral
- ② High
- ③ Low
- ④ Reverse
- ⑤ Select lever shift rod

#### **NOTE:**

**Before shifting, you must stop the vehicle and take your foot off the accelerator pedal. Otherwise, the transmission may be damaged.**

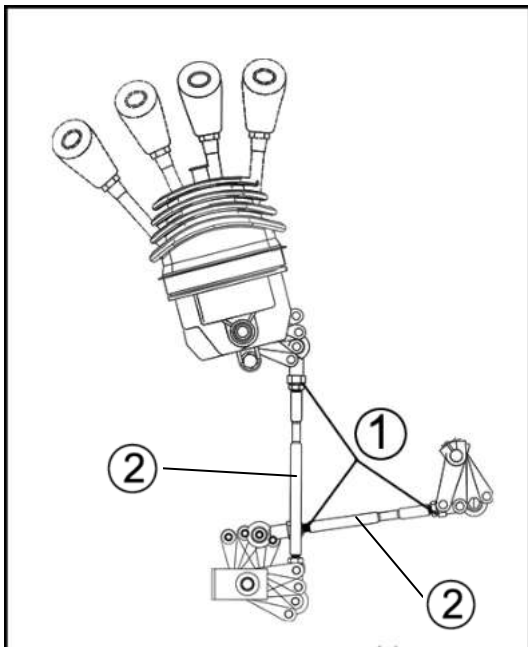

1. Adjust:
  - Select lever shift rod
  - a. Make sure the select lever is in NEUTRAL.
  - b. Loosen both in nuts ①.
  - c. Adjust the shift rod length for smooth and correct shifting ②.
  - d. Tighten the nuts ①.

#### **Nut**

**23 Nm (2.3 m · kg, 17 ft · lb)**

## Reverse mechanism parts

### CHECKING AND SERVICE OF REVERSE MECHANISM

1. Check the mobility of gear shift handle. If it is not working properly, remove the gear shift Mechanism to check if the fork , ball and spring is stuck.,in which case replace the defective component and try again.The last way is to turn to the professional repairman.
2. If there is lack in the gear shift mechanism , adjust the nut of the fork to correct position and strengthen gear shift mechanism .
3. Remove the gear shift mechanism and check whether the linking rod is cracked; If so, it should be changed.
4. Check whether the bouncing spring of gear shift mechanism is intense enough.
5. Check whether the gear is engaged correctly and whether there are tripstop or lack. If these situation exists, call for the staff to test and repair it.
6. If the gear can not be engaged, we can test it from the following aspects:
  - whether the clutch can completely declutch;
  - whether the gearshift is greased reliable(whether the oil pipe of gear shift mechanism is blocked);
  - whether gear shift mechanism jams;If these situation happens, maintanance staff would come to test and repair it.

# CHASSIS

## SUSPENSION

### Front Swing Arm

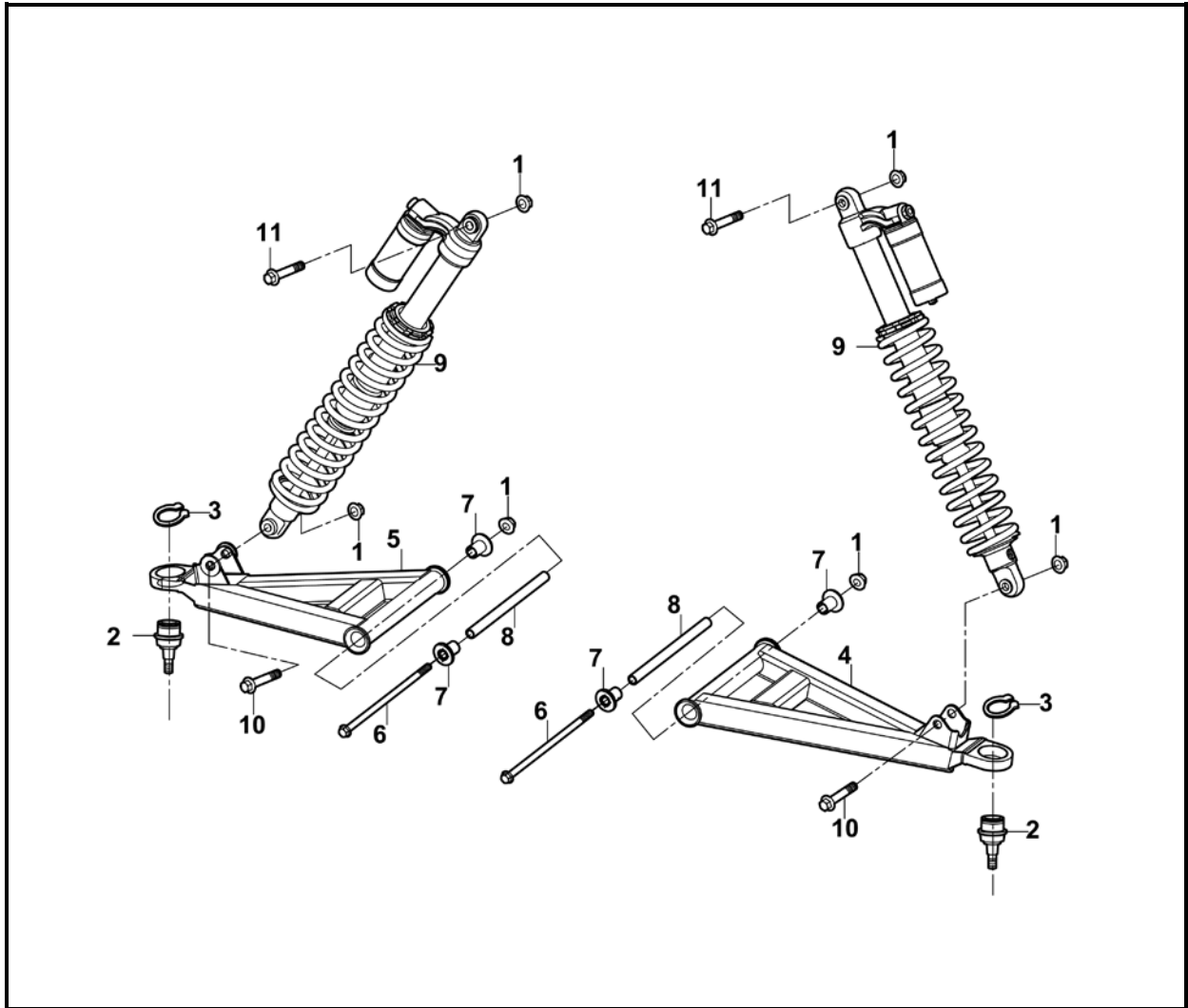

No.	Part Name	Qty	Remarks
	<b>Removing the front swing arm</b>		
1	Hexagon flange nut M10×1.25	4	
2	Joint A, suspension	2	
3	Circlip D0=30	4	
5	Left front upper swing arm	1	
6	Right front upper swing arm	1	
7	Hexagon flange bolt M10×1.25×230	2	
8	Nylon bush $\Phi 14 \times \Phi 19 \times \Phi 35 \times 30$	4	
9	Liner tube	2	
10	Hexagon bolt M10×1.25×55	2	
11	Hexagon bolt M10×1.25×55	2	



# CHASSIS

## Front Suspension

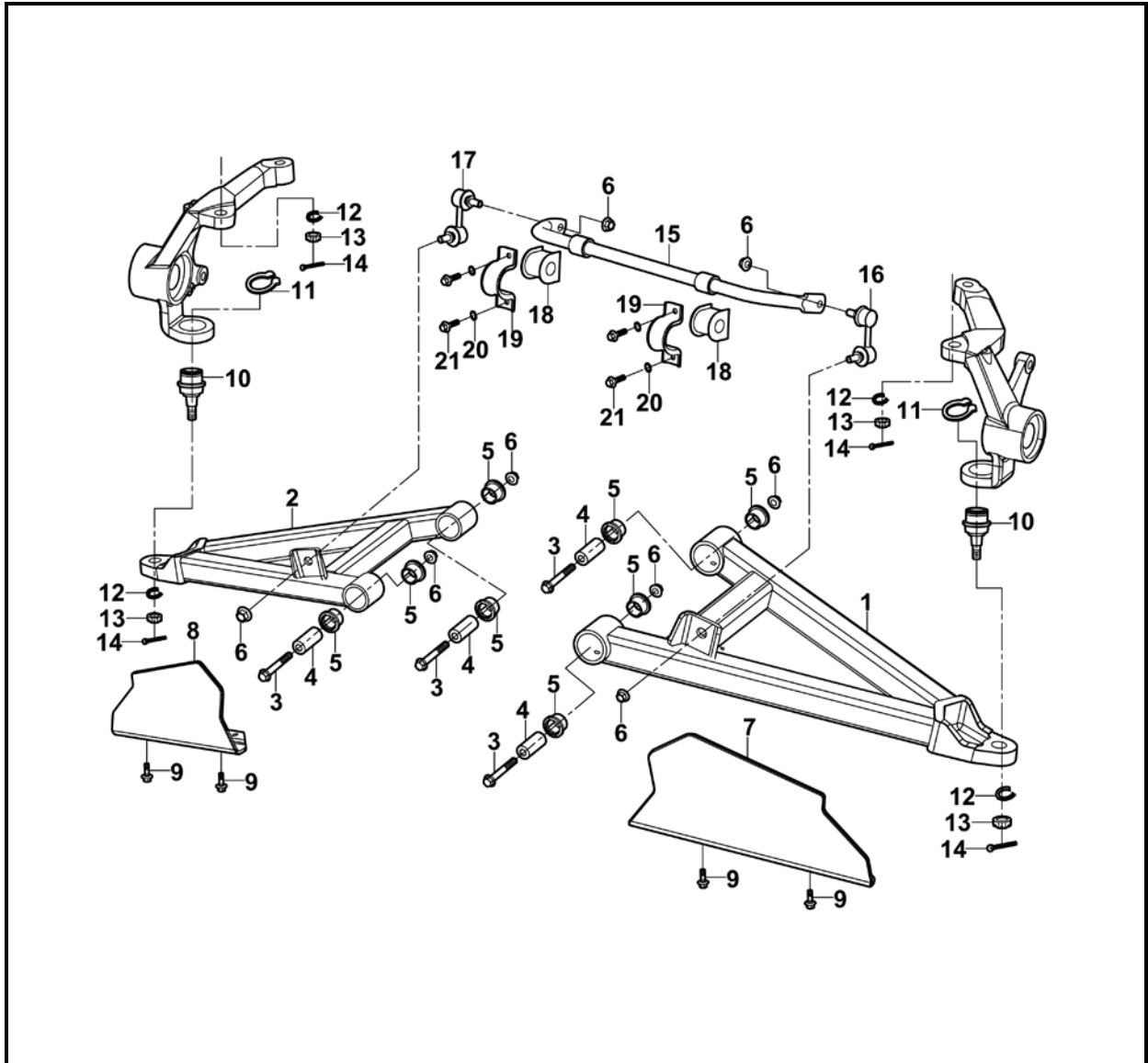

No.	Part Name	Qty	Remarks
	<b>Removing the front suspension</b>		
1	Left front lower swing arm	1	
2	Right front lower swing arm	1	
3	Hexagon flange bolt M10×1.25×70	4	
4	Bush Φ10×Φ23×50	4	
5	Nylon bush Φ22×Φ28×Φ35×20	16	
6	Hexagon flange nut M10×1.25	6	
7	Protective board, right lower swing arm	1	
8	Protective board, left lower swing arm	1	
9	Hexagon flange bolt M6×16	4	
10	Joint A, suspension	2	

# CHASSIS

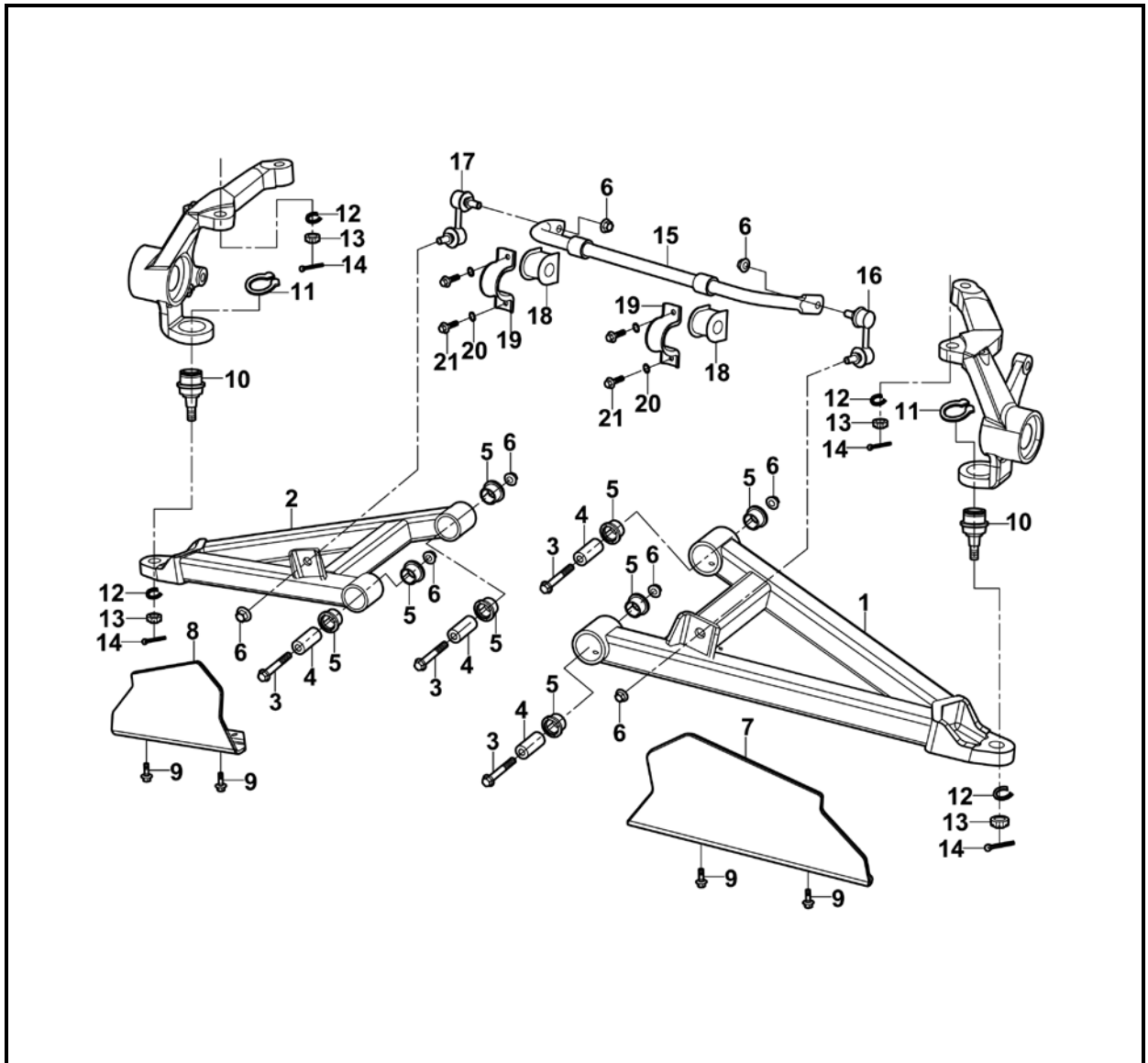

No.	Part Name	Qty	Remarks
11	Circlip D0=30	4	
12	Spring washer -12	4	
13	Hexagon nut M12×1.25	4	
14	Cotter pin 2.5×30	4	
15	Front anti-roll bar	1	
16	Left tie-rod, anti-roll bar	1	
17	Right tie-rod, anti-roll bar	1	
18	"U" type rubber bush III	2	
19	Press block, rear anti-roll bar	2	
21	Split washer-8	4	
21	Hexagon flange bolt M8×16	4	

## Front Suspension and arm

### DISASSEMBLING, SERVICE AND ASSEMBLY THE SUPPORTING ROCKER PARTS

#### 1. Disassembling and Service

In the suspension, there is easy to appear the problem with bushing, cotter pin and shock absorber.

·If the left and right rocker rocks fiercely, check the few aspect, whether the bushing of the rocker is crushed, the middle rubber separate is aging and chapped.

· check whether the cotter pin is credible, if it is not instead the same spec cotter pin.

·The problem with the shock absorber and maintain method, whether it can returns to the position under the pressure and the torsional spring is rupture. If it is rupture or nearly to rupture, instead the shock absorber. whether it leak oil, if so instead the same spec shock absorber. According to the different request, if there is a oil cup on the rocker, must check it whether complete and refuels.

#### 2. Install:

Mount fore L/R damper, up-and-down rocker arm assembly onto the frame with Flange Bolt, M10 nuts, Flange Bolt and M10 Nut, self-locking to ensure a torque of 40 ~ 45Nm.

#### **CAUTION:**

---

·**These components should be greased with butter before assembly.**

·**The surface of components can not be cracked.**

---

# CHASSIS

## Front Suspension and arm

·Check whether these components are greased with butter and then tighten the up-and-down rocker arm assembly and L/R fore dampers and their components. Fix the L/R tension rods into hole by way of the trough of open-groove nut with cotter pin and make these tension rods bisection on feet.

### CHECKING THE STEERING KNUCKLES

1. Check:

- steering knuckles  
Damage/pitting → Replace

### CHECKING THE FRONT ARMS

1. Check:

- front arms  
Bends/damage → Replace.

2. Check:

- Middle bushing  
Wear/damage → Replace.

3. Check:

- ball joints  
Damage/pitting → Replace the ball joint.  
Free play → Replace the ball joint.  
Turns roughly → Replace the ball joint.

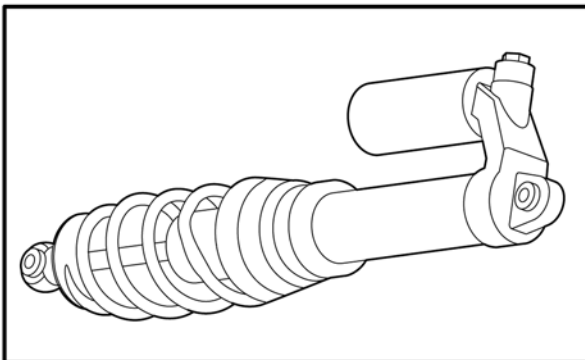

### CHECKING THE FRONT SHOCK ABSORBER

1. Check:

- shock absorber rod  
Bends/damage → Replace the shock absorber assembly.
- shock absorber assembly  
Oil leaks → Replace the shock absorber assembly.
- spring  
Fatigue → Replace the shock absorber assembly.

Move the spring up and down.

# CHASSIS

## Front Suspension and arm

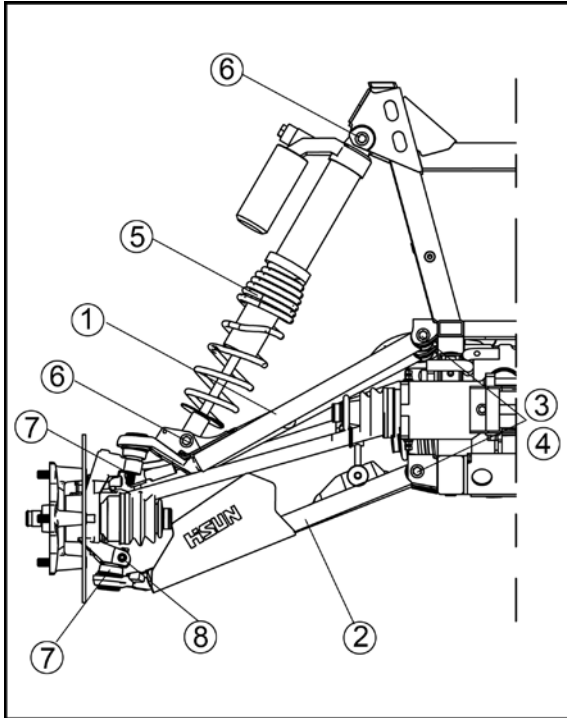

### INSTALLING THE FRONT ARMS AND FRONT SHOCK ABSORBER

1. Install:

- front arms
- front shock absorber

a. Install the front upper arm ① and front lower arm ②.

#### **NOTE:**

- Lubricate the bolts ③ with lithium-soap-based grease.
- Be sure to position the bolts ③ so that the bolt head faces inward.
- Temporarily tighten the nuts ④.

b. Install the front shock absorber ⑤.

**Nut ⑥**

**45 Nm (4.5 m · kg, 32 ft · lb)**

c. Install the front knuckle.

**Nut ⑧**

**45 Nm (4.5 m · kg, 32 ft · lb)**

d. Tighten the nuts ④.

**Nut ④**

**45 Nm (4.5 m · kg, 32 ft · lb)**

# CHASSIS

## Rear Suspension

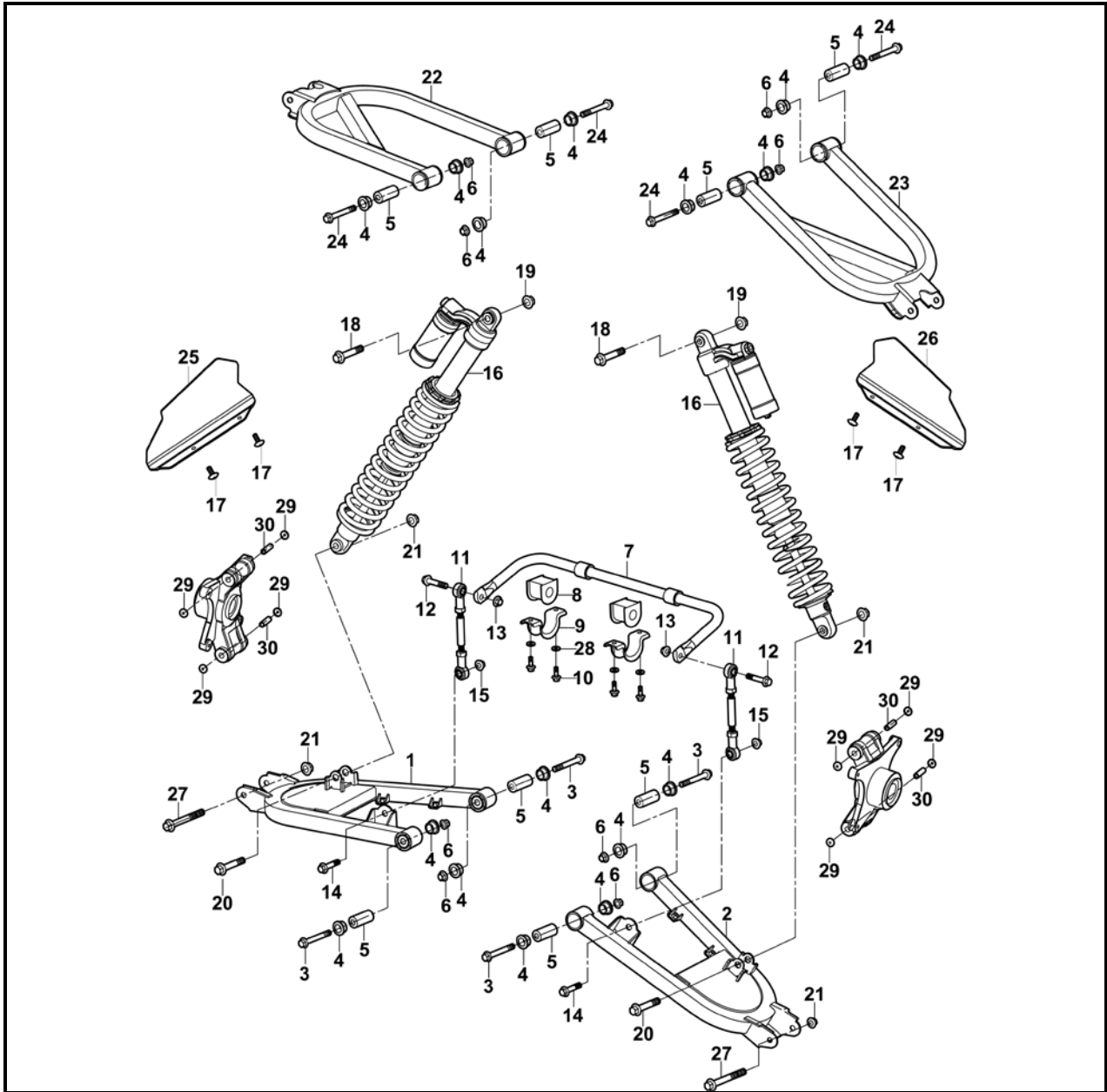

No.	Part Name	Qty	Remarks
	<b>Removing the rear suspension</b>		
1	Rear right lower swing arm	1	
2	Rear left lower swing arm	1	
3	Hexagon flange bolt M10×1.25×70	4	
4	Nylon bush Φ22×Φ28×Φ35×20	16	
5	Bush Φ10×Φ23×50	8	
6	Hexagon flange nut M10×1.25	8	
7	Rear anti-roll bar	1	
8	"U" type rubber bush III	2	
9	Press block, rear anti-roll bar	2	

# CHASSIS

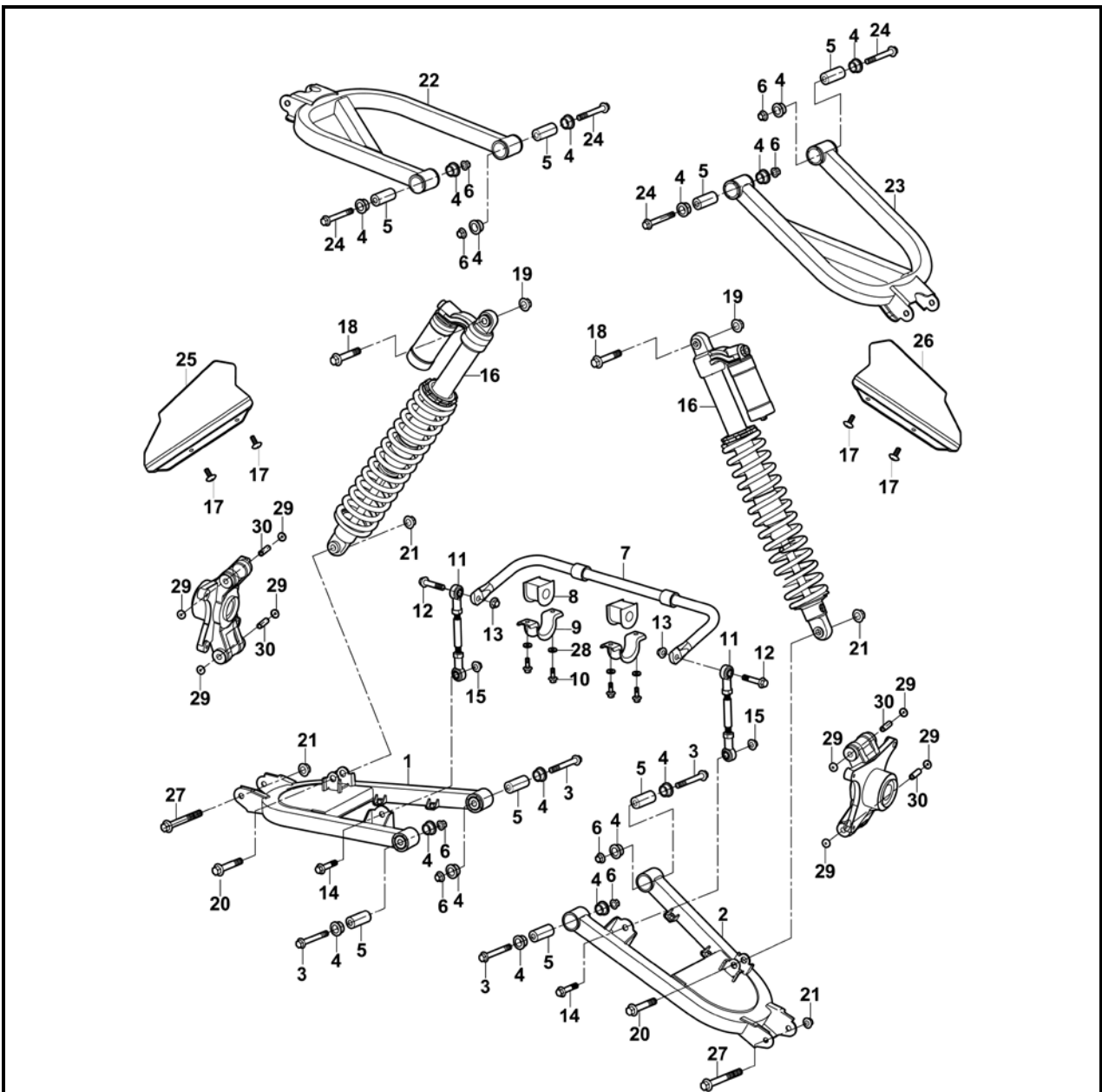

No.	Part Name	Qty	Remarks
10	Hexagon flange bolt M8×16	4	
11	Tie-rod assy, anti- roll bar	2	
12	Hexagon flange bolt M10×1.25×45	2	
13	Hexagon flange nut M10×1.25	2	
14	Hexagon flange bolt M10×1.25×40	2	
15	Hexagon flange nut M10×1.25	2	
16	Rear shock absorber	2	
17	Hexagon flange bolt M6×16	4	
18	Hexagon flange bolt M12×1.25×60	2	
19	Hexagon flange nut M12×1.25	2	
20	Hexagon flange bolt M12×1.25×60	2	

# CHASSIS

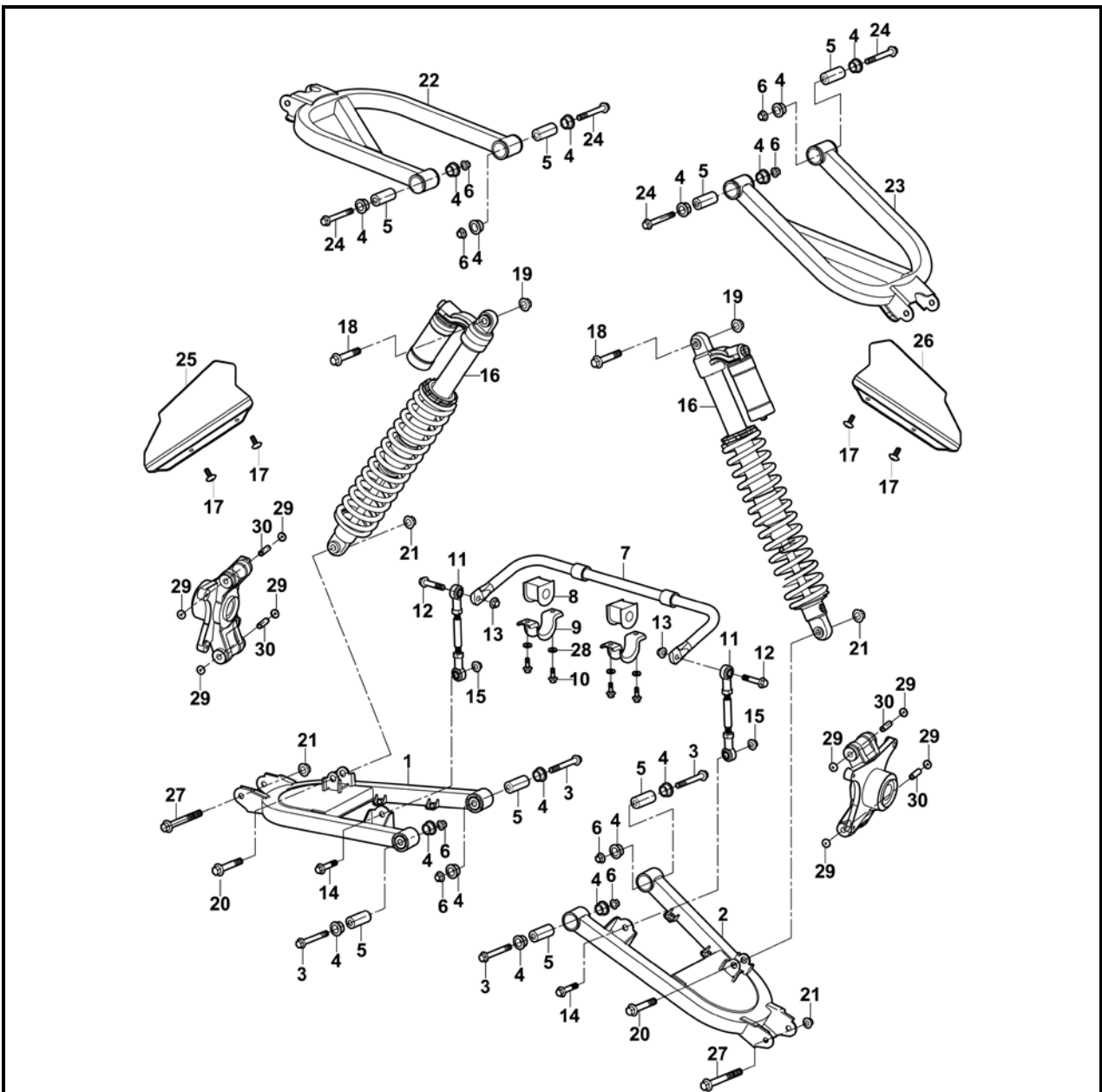

No.	Part Name	Qty	Remarks
21	Hexagon flange nut M12×1.25	2	
22	Rear Right upper swing arm	1	
23	Rear left upper swing arm	1	
24	Hexagon flange bolt M10×1.25×70	4	
25	Protective board, right lower swing arm	1	
26	Protective board, left lower swing arm	1	
27	Hexagon flange bolt M10×1.25×115	4	
28	Split washer-8	4	
29	Dust P. cover	8	
30	Axle sleeve, liner	4	



## CHASSIS

---

### Rear Suspension and arm

#### CHECKING AND SERVICE OF REAR SUSPENSION

1. It is similar to the front suspension ,Check if there exists any distortion or crack on the install axis of the shock absorber in which case it must be replaced.
2. Inspect the rocker bushing and the middle rubber separate is integrant.( According to the front Suspension)
3. The cotter pin on the head of the install axis which in the rear shock absorber whether is credible.

**NOTE:**

---

**After disassemble the rear shock absorber, check if there exists any distortion or crack on the frame connection hole and the rear shock absorber, if so, inform the special serviceman to inspect and service first or install the rear shock absorber on the frame after instead.(Attention, the bolts must be the special self-lock nut, the fastening torque must be 45-55Nm)**

---

# CHASSIS

## Rear Suspension and arm

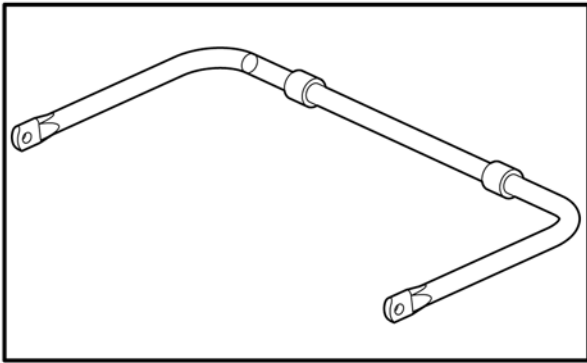

### CHECKING THE STABILIZER

1. Check:
  - bar, stabilizerBends/cracks/damage → Replace.

### CHECKING THE STEERING KNUCKLES

1. Check:
  - steering knucklesDamage/pitting → Replace

### CHECKING THE REAR ARMS

1. Check:
  - rear armsBends/damage → Replace.
2. Check:
  - Middle bushingWear/damage → Replace.

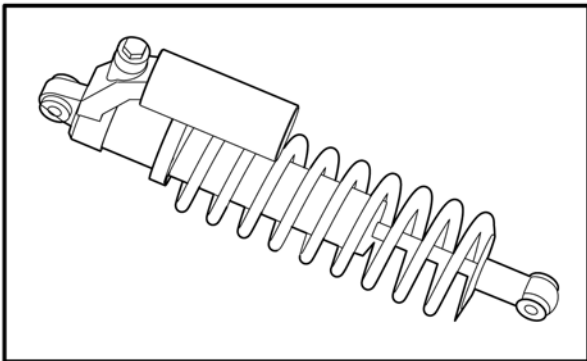

### CHECKING THE REAR SHOCK ABSORBER

1. Check:
  - shock absorber rod
    - Bends/damage → Replace the shock absorber assembly.
  - shock absorber assembly
    - Oil leaks ⇒  Replace the shock absorber assembly.
  - spring
    - Move the spring up and down.
    - Fatigue → Replace the shock absorber assembly.

# CHASSIS

## INSTALLING THE REAR ARMS AND REAR SHOCK ABSORBER

1. Install:
  - rear arms
  - rear shock absorber

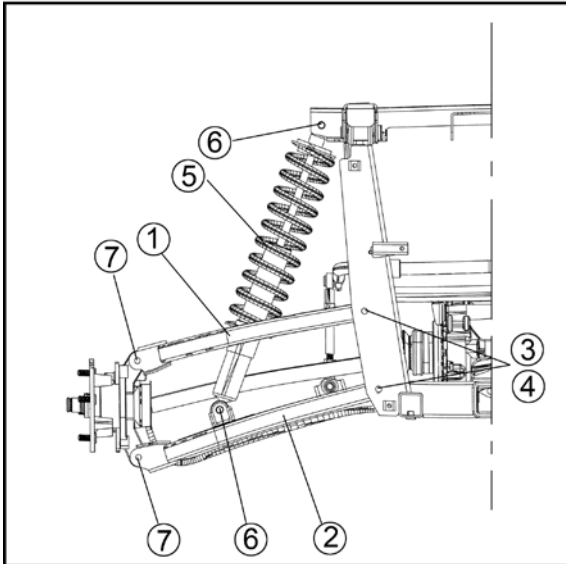

- a. Install the rear upper arm ① and rear lower arm ②.

### NOTE:

- Lubricate the bolts ③ with lithium-soap-based grease.
- Be sure to position the bolts ③ so that the bolt head faces outward.
- Temporarily tighten the nuts ④.

- b. Install the rear shock absorber ⑤.

#### Nut ⑥

45 Nm (4.5 m · kg, 32 ft · lb)

- c. Install the new cotter pins.

- d. Tighten the nuts.

#### Nut ④ ③

45 Nm (4.5 m · kg, 32 ft · lb)

# CHASSIS

## COOLING SYSTEM

### Water And Oil Radiator

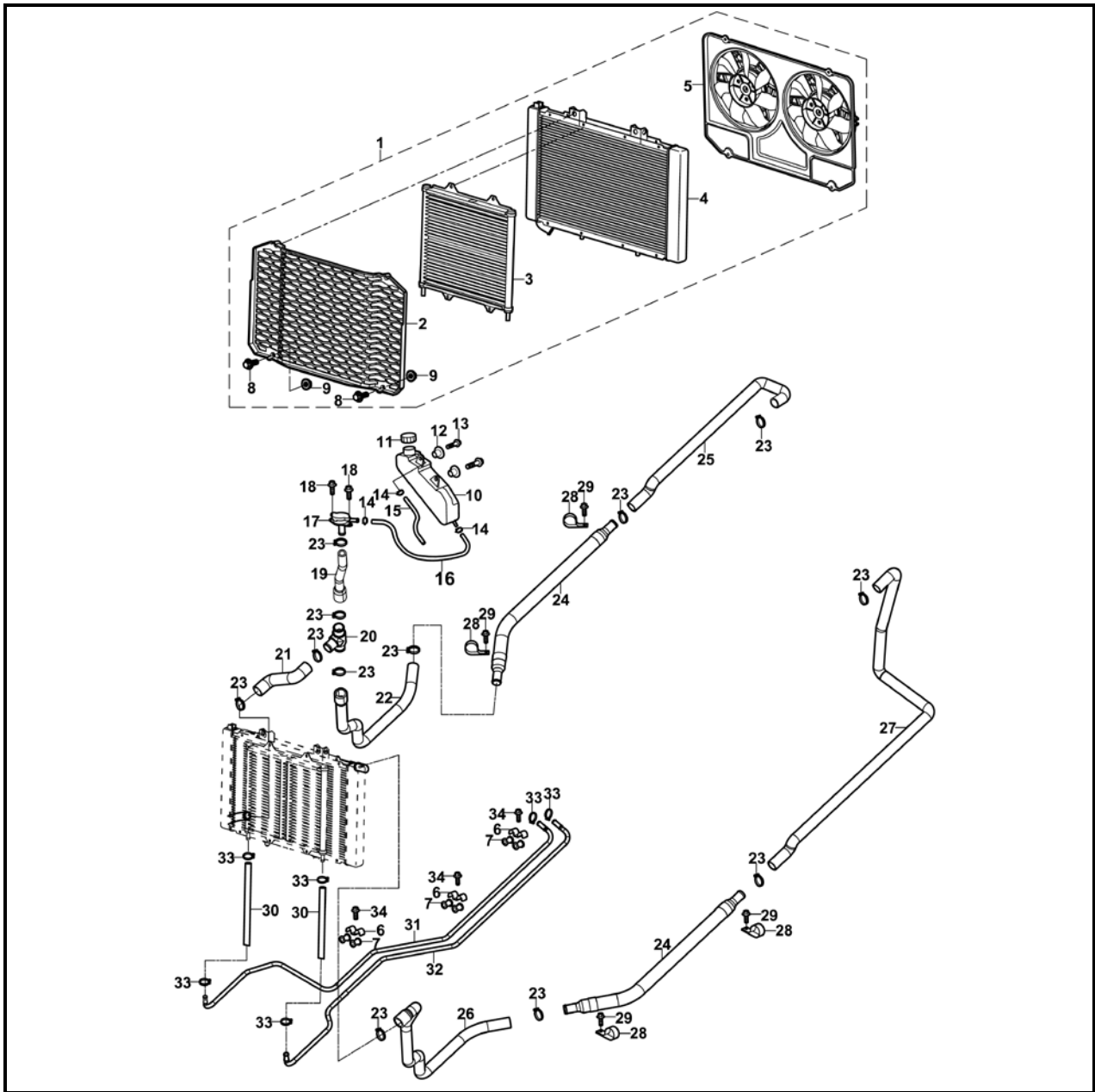

No.	Part Name	Qty	Remarks
	<b>Removing the radiator</b>		
1	Water tank	1	
2	Radiator cover	1	
3	Oil cooler	1	
4	Radiator assy	1	
6	Radiator fan assy	1	
7	M-shaped fixed pipe clamps	3	
8	H-shaped rubber washer	6	

# CHASSIS

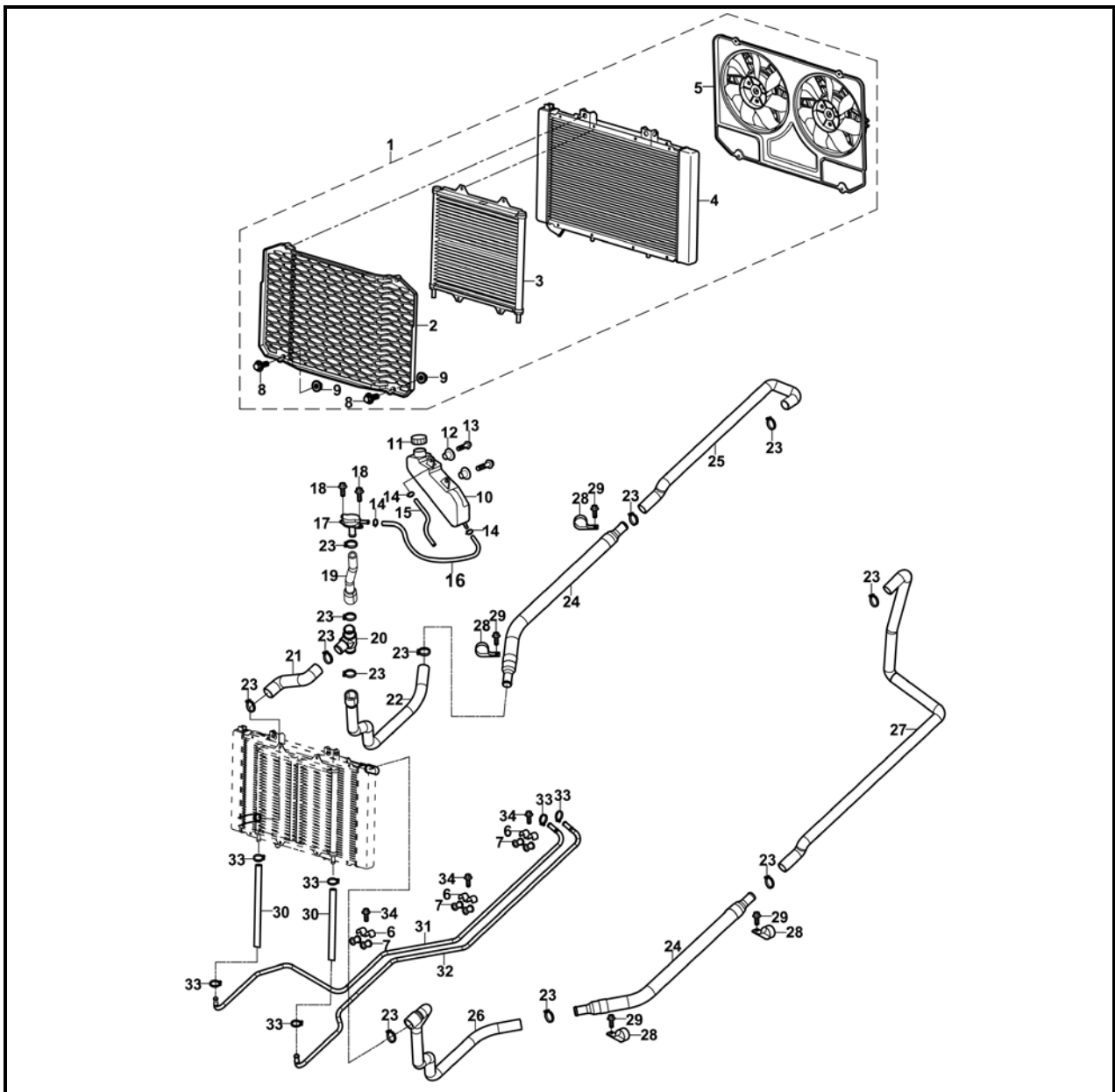

No.	Part Name	Qty	Remarks
9	Hexagon flange nut M6	2	
10	Secondary water tank	1	
11	Secondary water tank cover	1	
12	Collar bushing $\Phi 6 \times \Phi 9 \times \Phi 22 \times 6.5$	2	
13	Hexagon flange bolt M6 $\times$ 16	2	
14	Clip $\Phi 9$	3	
15	Rubber tube $\Phi 5 \times \Phi 9 \times 550$		
16	Rubber pipe $\Phi 7 \times \Phi 11 \times 750$	1	
17	Water inlet assy	1	
18	Hexagon flange bolt M6 $\times$ 16	2	
19	Water pipe	1	

# CHASSIS

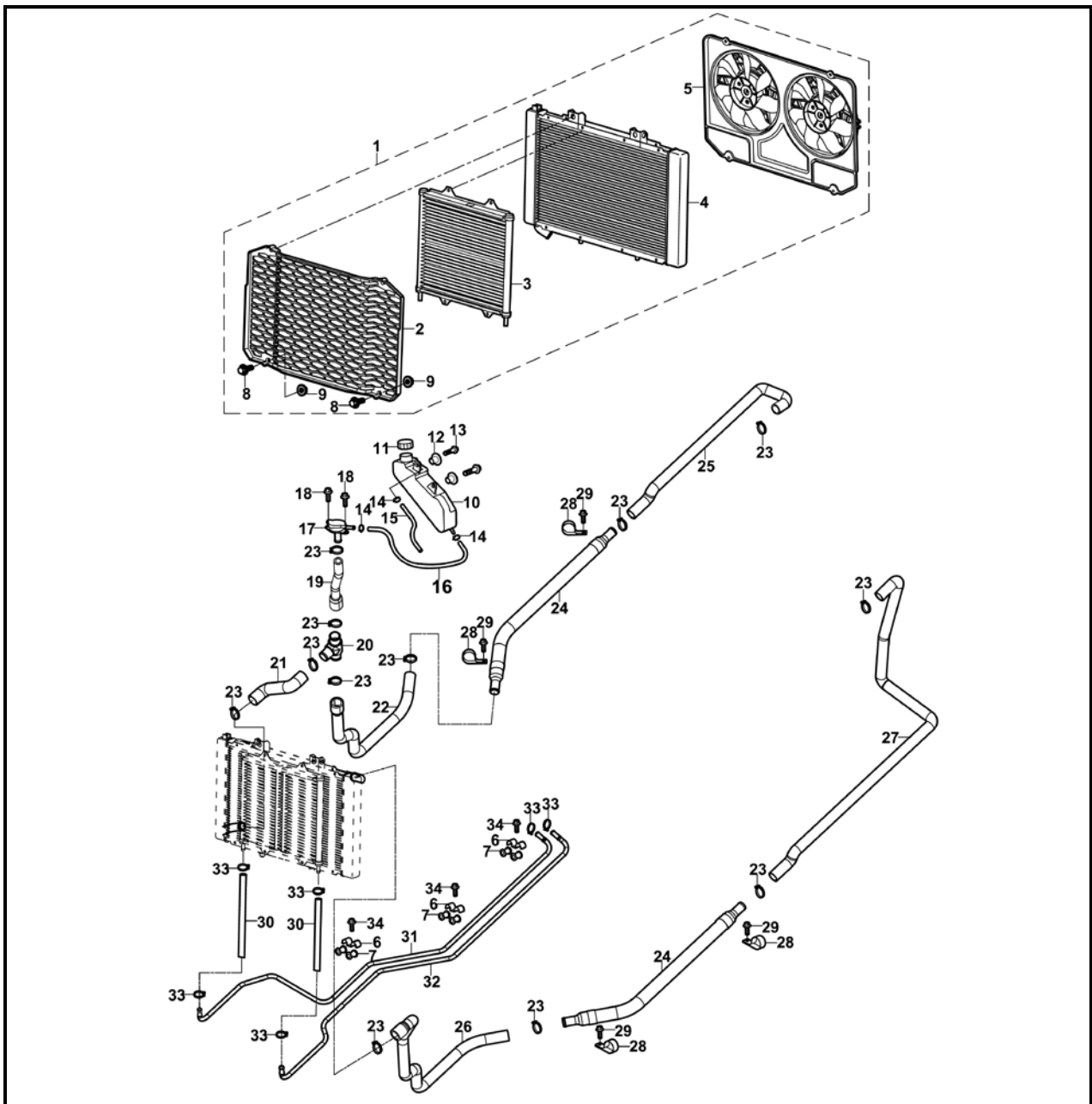

No.	Part Name	Qty	Remarks
20	Aluminum pipe joint	1	
21	Middle water pipe(R)	1	
22	Front water pipe(R)	1	
23	Screw hoop $\Phi 20-32$	12	
24	Metal water pipe	2	
25	Rear right water pipe	1	
26	Front left water pipe	1	
27	Rear left water pipe	1	
28	Clip , metal water pipe	4	
29	Hexagon flange bolt M6×16	4	

# CHASSIS

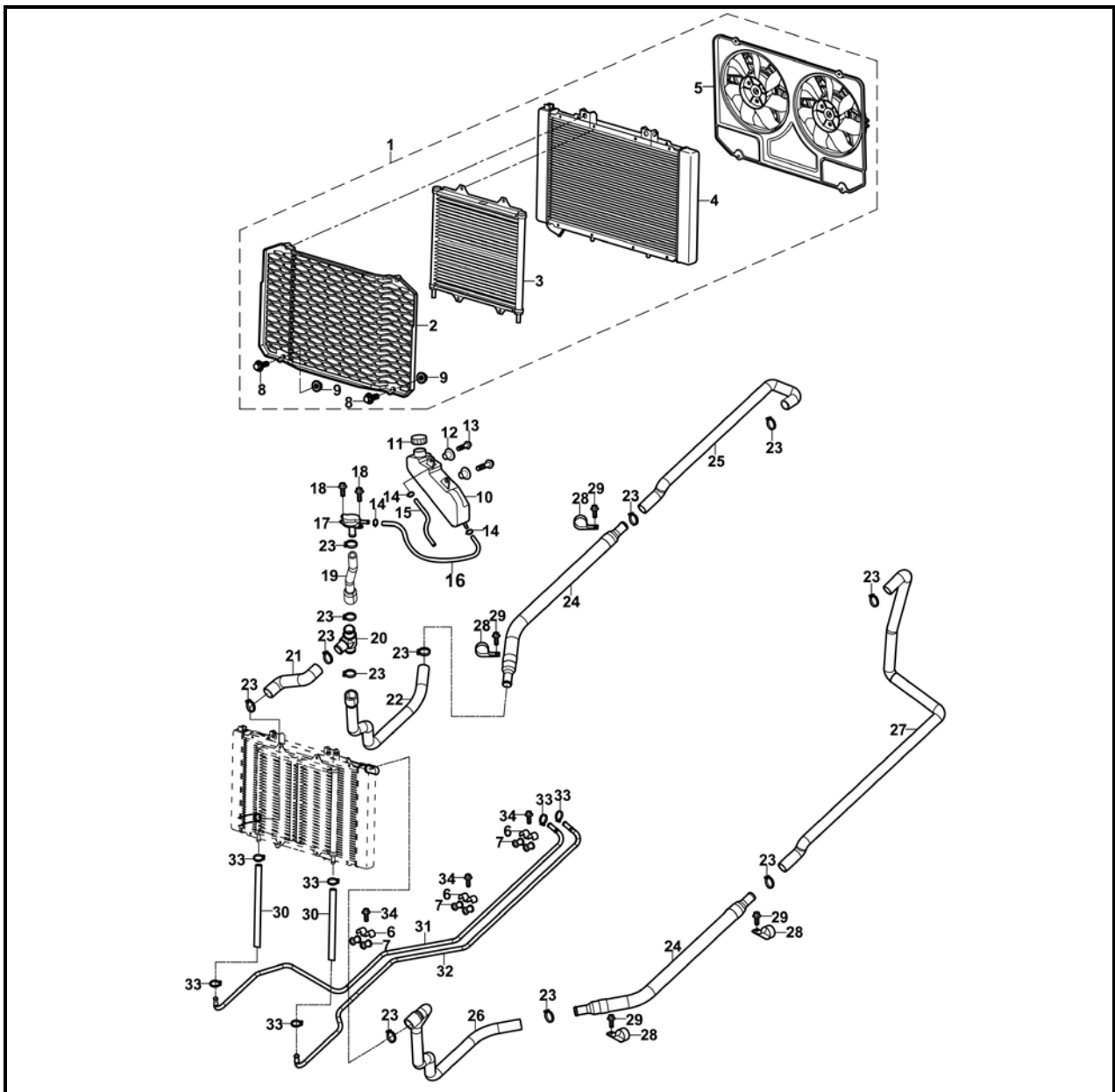

No.	Part Name	Qty	Remarks
30	Pressure-proof rubber oil pipe I $\Phi 10 \times \Phi 17 \times 300$	2	
31	Metal oil pipe I	1	
32	Metal oil pipe II	1	
33	Screw hoop $\Phi 12-20$	6	
34	Hexagon flange bolt M6 $\times$ 12	3	

## CHASSIS

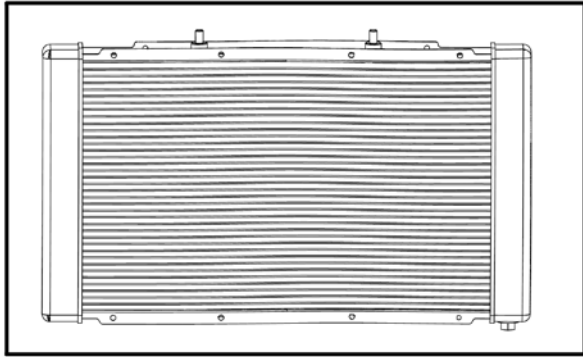

### CHECKING THE RADIATOR

1. Check:

- radiator fins

Obstruction → Clean.

Apply compressed air to the rear of the radiator

Damage → Repair or replace.

**NOTE:**

**Straighten any flattened fins with a thin, flat-head screwdriver.**

2. Check:

- all rubber hose

Cracks/damage → Replace.

3. Check:

- Bolt clip

the tightness of Bolt clip. If loosen, please have the hoop tightened immediately.

4. Check:

- radiator fan

Damage → Replace.

Malfunction → Check and repair.

5. Measure:

- radiator cap opening pressure

Below the specified pressure → Replace the radiator cap.

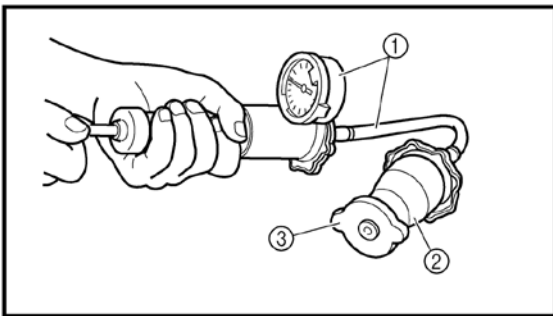

**Radiator cap opening pressure**

**107.9 ~ 137.3 KPa**

**(1.079 ~ 1.373 kg/cm<sup>2</sup>, 15.35 ~ 19.53 psi)**

a. Install the radiator cap tester ① and adapter

② onto the radiator cap ③.

b. Apply the specified pressure for ten seconds and make sure that there is no drop in pressure.



## CHASSIS

---

### INSTALLING THE RADIATOR

#### 1. Fill:

- cooling system

Start engine when pour full the refrigerating fluid, loose the exhaust nut on the pipe, the water level will get lower at this time, Supply the refrigerating fluid until the water level stop to change, then screw the exhaust nut, cover the water tank lid.

The water tank inspection is finished. .

#### 2. Check:

- cooling system

Leaks → Repair or replace any faulty part.

## CHASSIS

---

### CHECKING THE OIL COOLER

1. Check:

- oil cooler

Obstruction → Clean.

Apply compressed air to the rear of the oil cooler.

Damage → Repair or replace the oil cooler.

**NOTE:**

---

**Straighten any flattened fins with a thin, flathead screwdriver.**

---

2. Check:

- oil pipes

Cracks/damage →  Replace.

# CHASSIS

## SEAT (Bench seat)

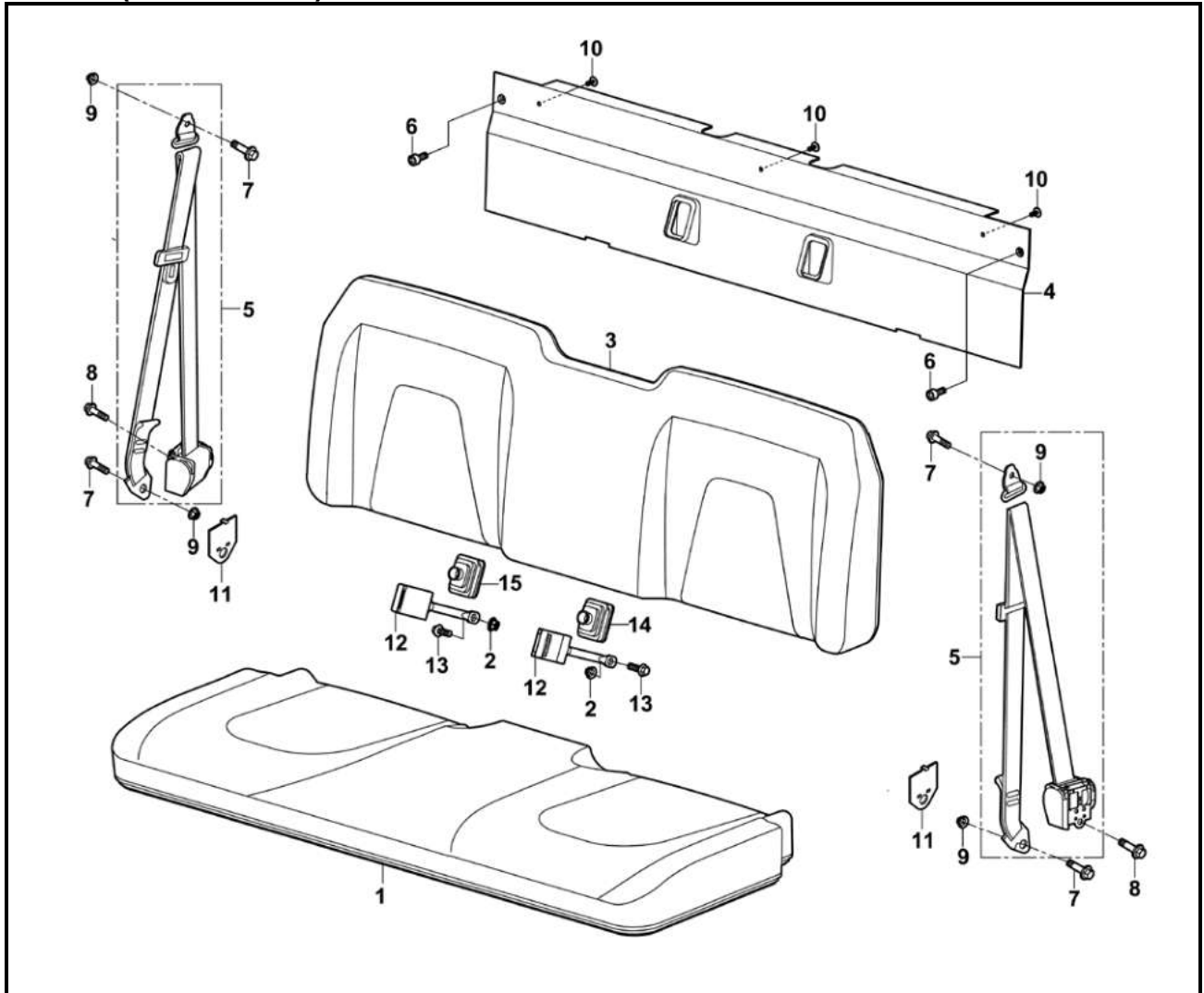

No.	Part Name	Qty	Remarks
	<b>Removing the seat</b>		
1	Bench seat	1	
2	Hexagon flange nut M10×1.25	2	
3	Backrest assy	1	
4	Baffle plate	1	
5	Safety belt assy	2	
6	Hexagon socket head bolt M6×20	2	
7	Hexagon flange step bolt M10×1.25×20-Φ14×5	4	
8	Hexagon flange bolt M10×1.25×20	2	
9	Hexagon flange nut M10×1.25	4	
10	Cross large plate head screw M6×16	3	
11	Safety belt placing plate	2	
12	Safety belt buckle	2	
13	Hexagon flange bolt M10×1.25×20	2	
14	Rubber insulation (L)	1	
15	Rubber insulation (R)	1	

# CHASSIS

## SEAT (Bucket seat)

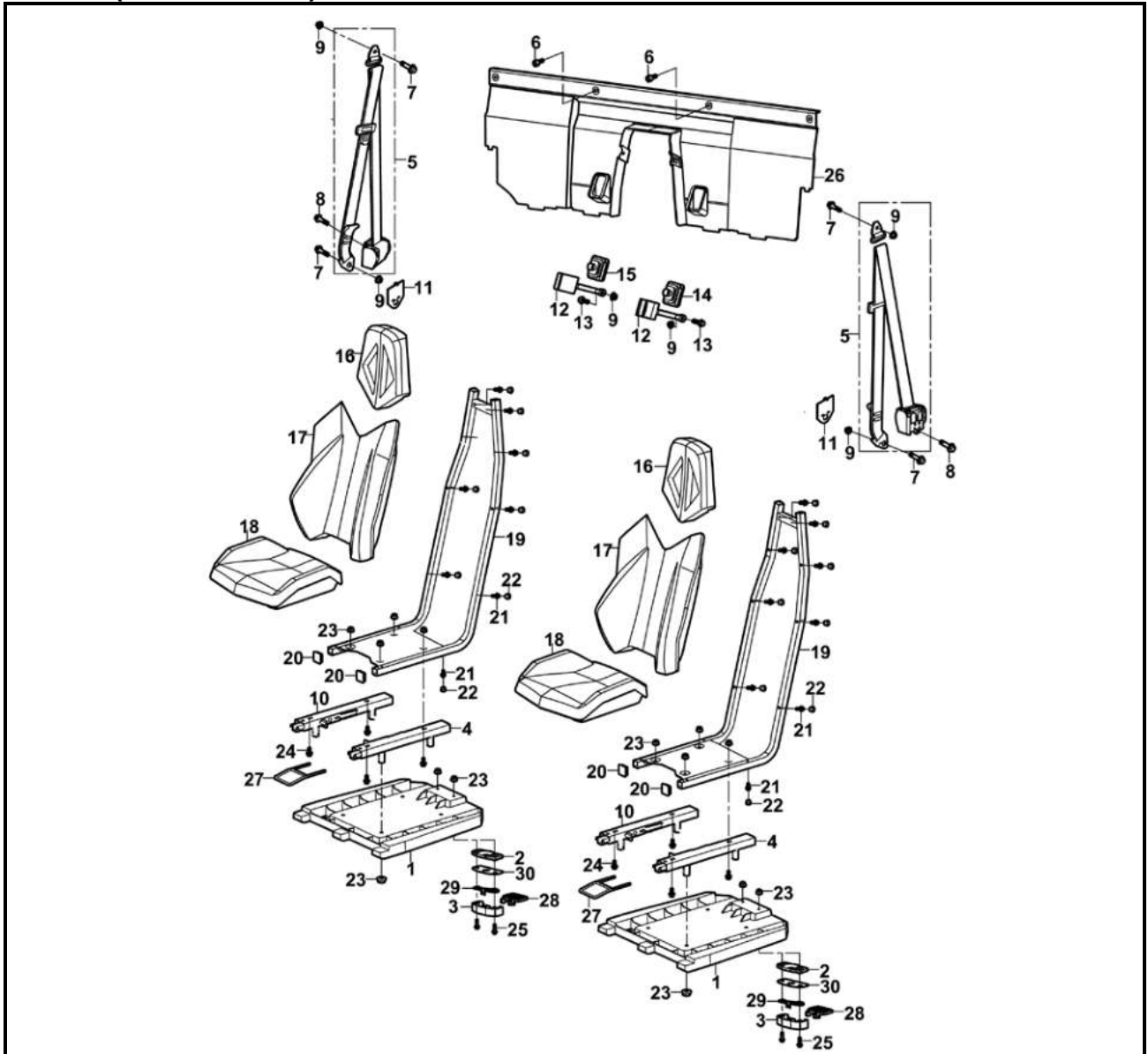

No.	Part Name	Qty	Remarks
	<b>Removing the seat</b>		
1	Seat mounting board	2	
2	Lock plate, seat	2	
3	Lock plate assy	2	
4	Slide rail comp.(L)	2	
5	Safety belt assy	2	
6	Hexagon socket head bolt m6×20	2	
7	Hexagon flange step bolt M10×1.25×20-Φ14×5	4	
8	Hexagon flange bolt M10×1.25×20	2	
9	Hexagon flange nut M10×1.25	6	
10	Slide rail comp.(R)	2	
11	Safety belt placing plate	2	
12	Safety belt buckle	2	

# CHASSIS

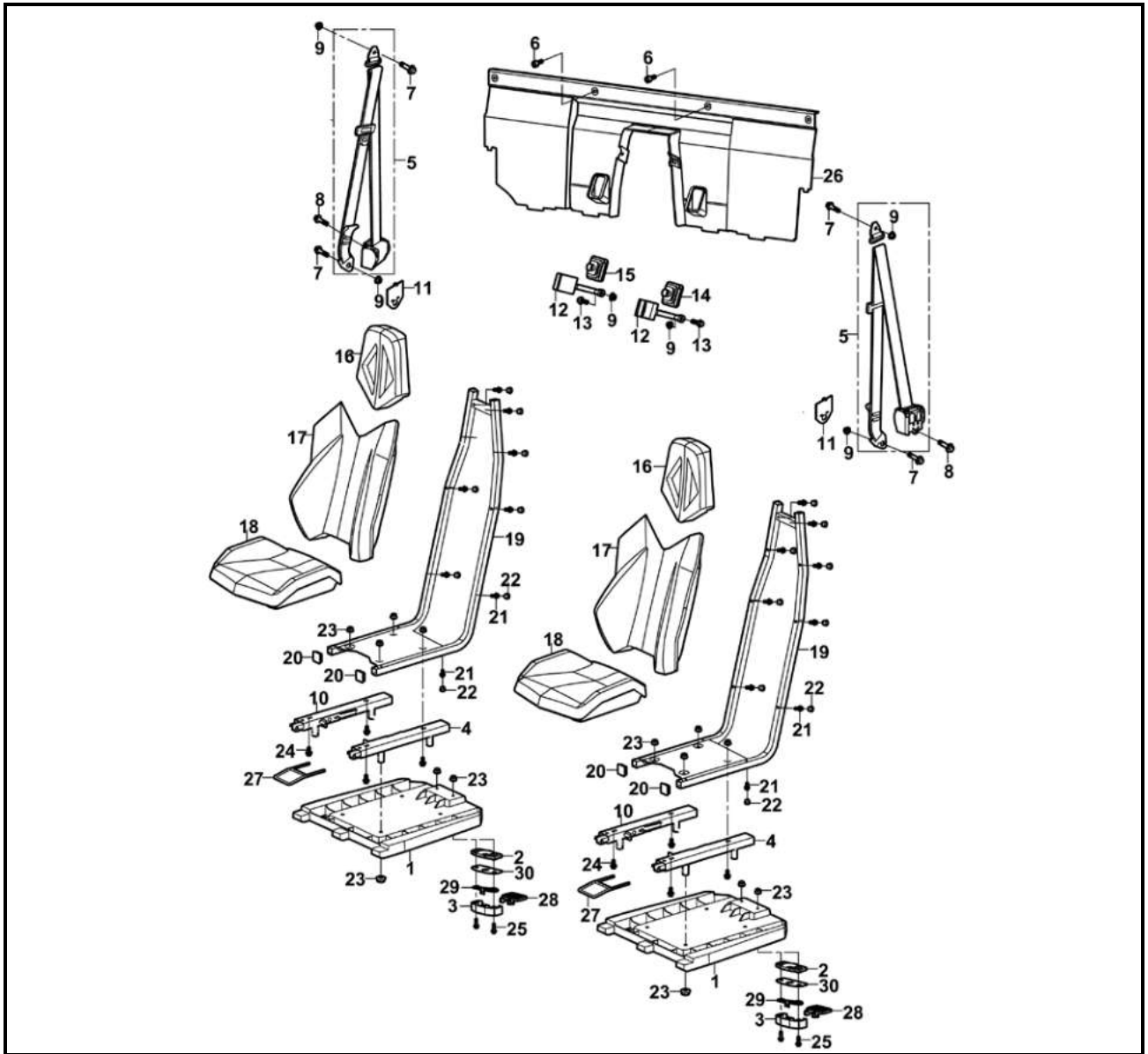

No.	Part Name	Qty	Remarks
13	Hexagon flange bolt M10×1.25×20	2	
14	Rubber insulation(L)	1	
15	Rubber insulation(R)	1	
16	Head rest	2	
17	Backrest assy	2	
18	Seat assy	2	
19	Front seat connect bracket assy	2	
20	Front plug 25×25	4	
21	Hexagon flange bolt M8×25	24	
22	Rubber Plug Φ19×Φ25×10	24	
23	Hexagon flange nut M8	20	
24	Hexagon flange bolt M8×16	8	
25	Hexagon flange bolt M8×40	4	

# CHASSIS

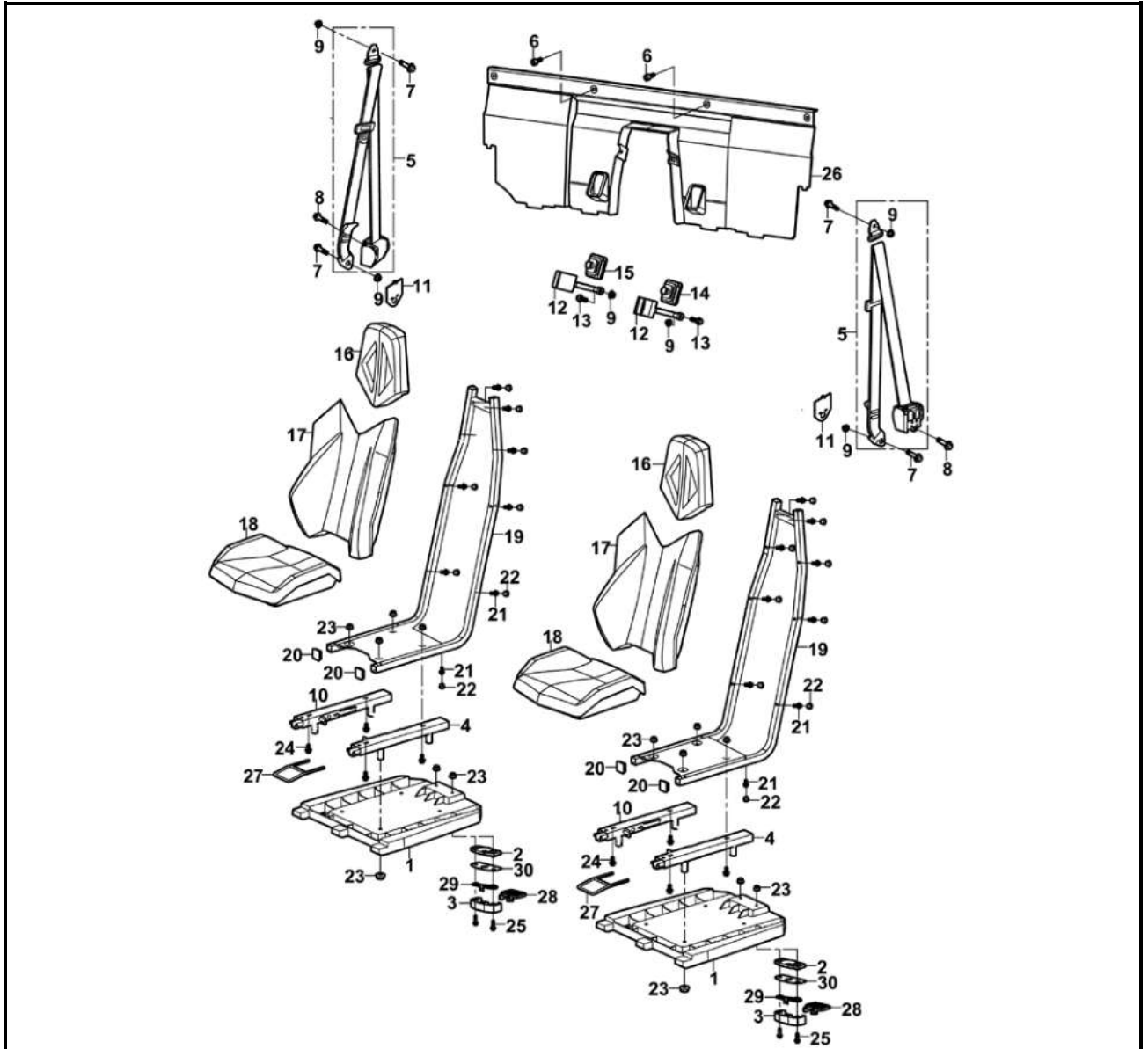

No.	Part Name	Qty	Remarks
26	Baffle plate	1	
27	Pull rod, side rail	2	
28	Seat Lock handle bar	2	
29	Lock spring, seat	2	
30	Spring board, seat	2	

## CHASSIS

---

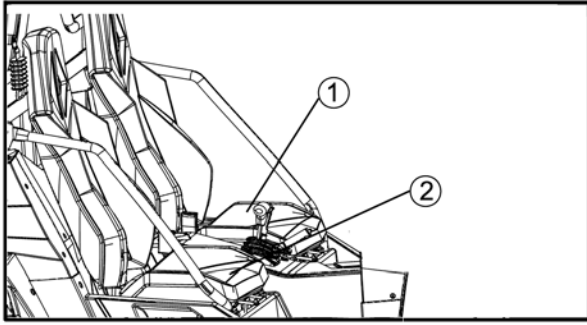

### DISASSEMBLING THE SEAT (Bucket seat)

Remove:

- Driver seat ①
- Passenger seat ②
- Bolt ③

To remove the seat, Remove bolts with socket wrench, and then remove the seat. Installation is the reverse of removal.

### CAUTION:

- These components should be greased with butter before assembly.
  - The surface of components can not be cracked.
- 

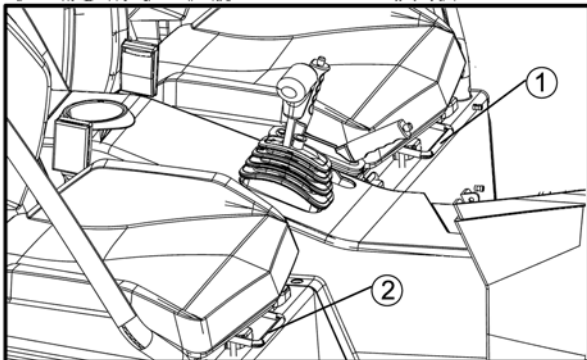
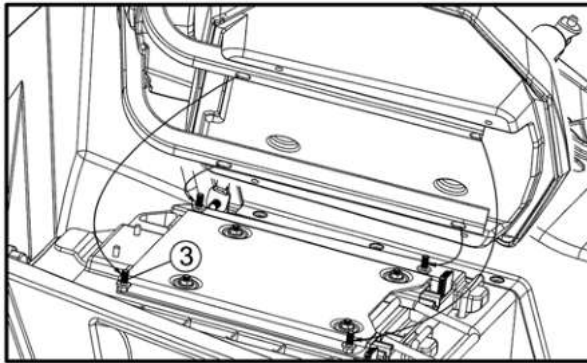

### Moving Seat Forward And Backward

- Driver seat handle ①
- Passenger seat handle ②

The seat can be moved forward and backward to fit the height of different drivers. Pull up the handle, then you can move the seat forward and backward.

### CAUTION:

To install the seat, Adjust the four bolts M8 cooperatively to ensure the seat can move forward and backward normally. Improper installation can result in seat rail blocked and failure to move the seat back and forth.

---

## CHASSIS

---

### DISASSEMBLING THE SEAT (Bench seat)

Remove:

- Driver seat and passenger seat ①

To open the seat, raise the seat to the forward position.

To remove the seat, Remove bolts with socket wrench, and then remove the seat. Installation is the reverse of removal.

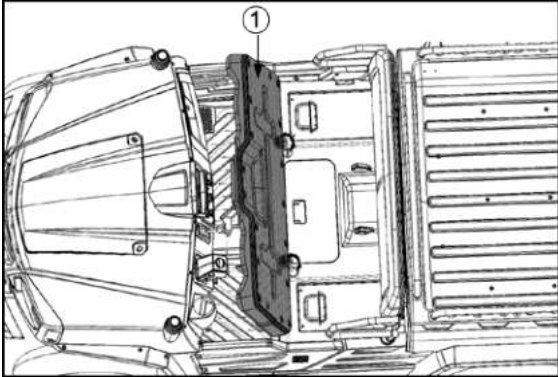

### CAUTION:

• These components should be greased with butter before assembly.

• The surface of components can not be cracked.

---



# CHASSIS

## FUEL TANK

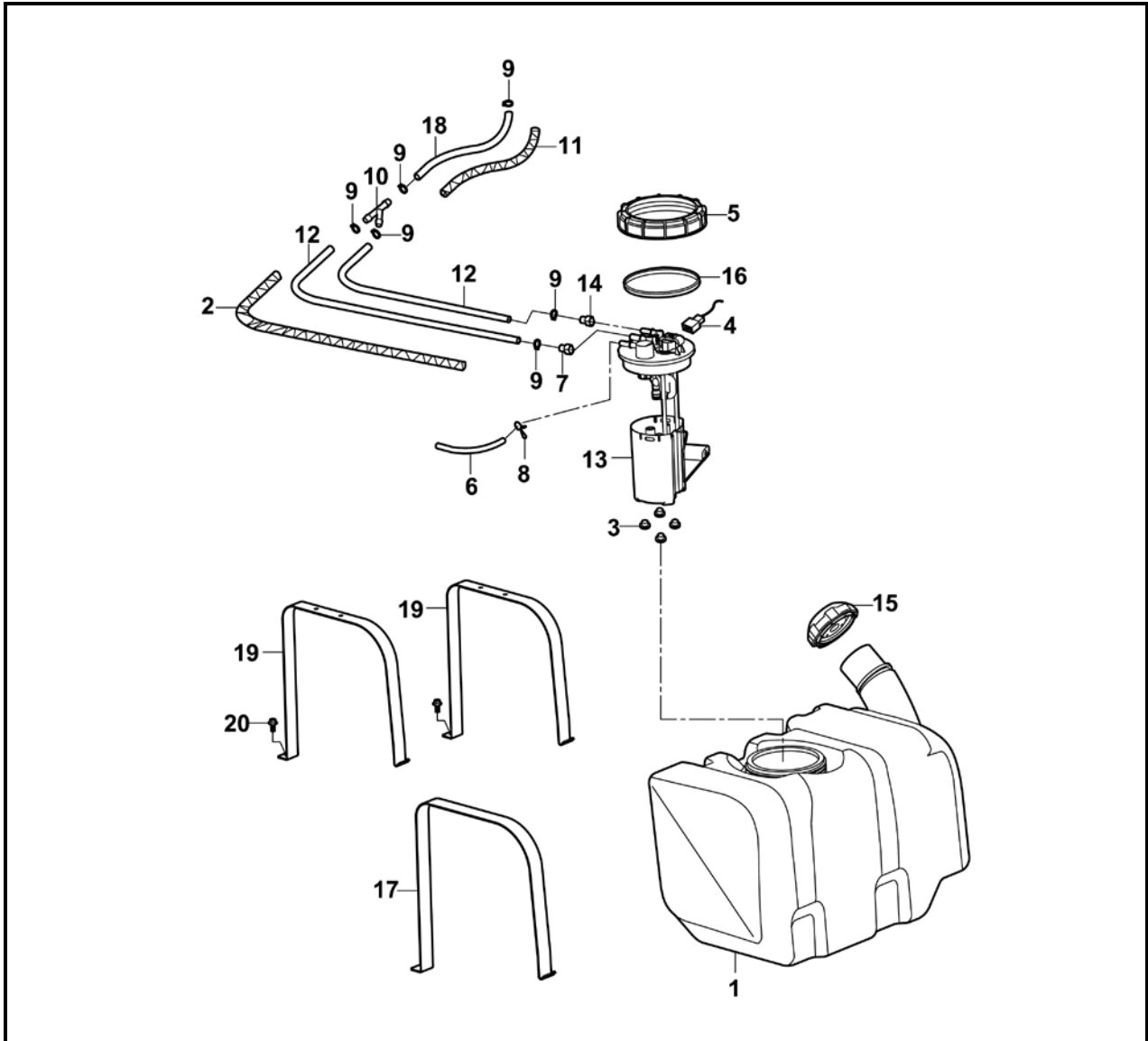

No.	Part Name	Qty	Remarks
	<b>Removing the fuel tank</b>		
1	Fuel tank	1	
2	Aluminum foil insulation bellows $\Phi 14 \times \Phi 17-220$	2	
3	Shock absorbtion rubber VIII	4	
4	Fuel pump connector	1	
5	Fuel pump cover	1	
6	Rubber tube $\Phi 7 \times \Phi 11 \times 700$	1	
7	Plug for fuel outlet	1	
8	Clip $\Phi 10$	1	
9	Clamp	6	
10	Triplet joint fuel pipe	1	
11	Aluminum foil insulation bellows $\Phi 14 \times \Phi 17-470$	1	

# CHASSIS

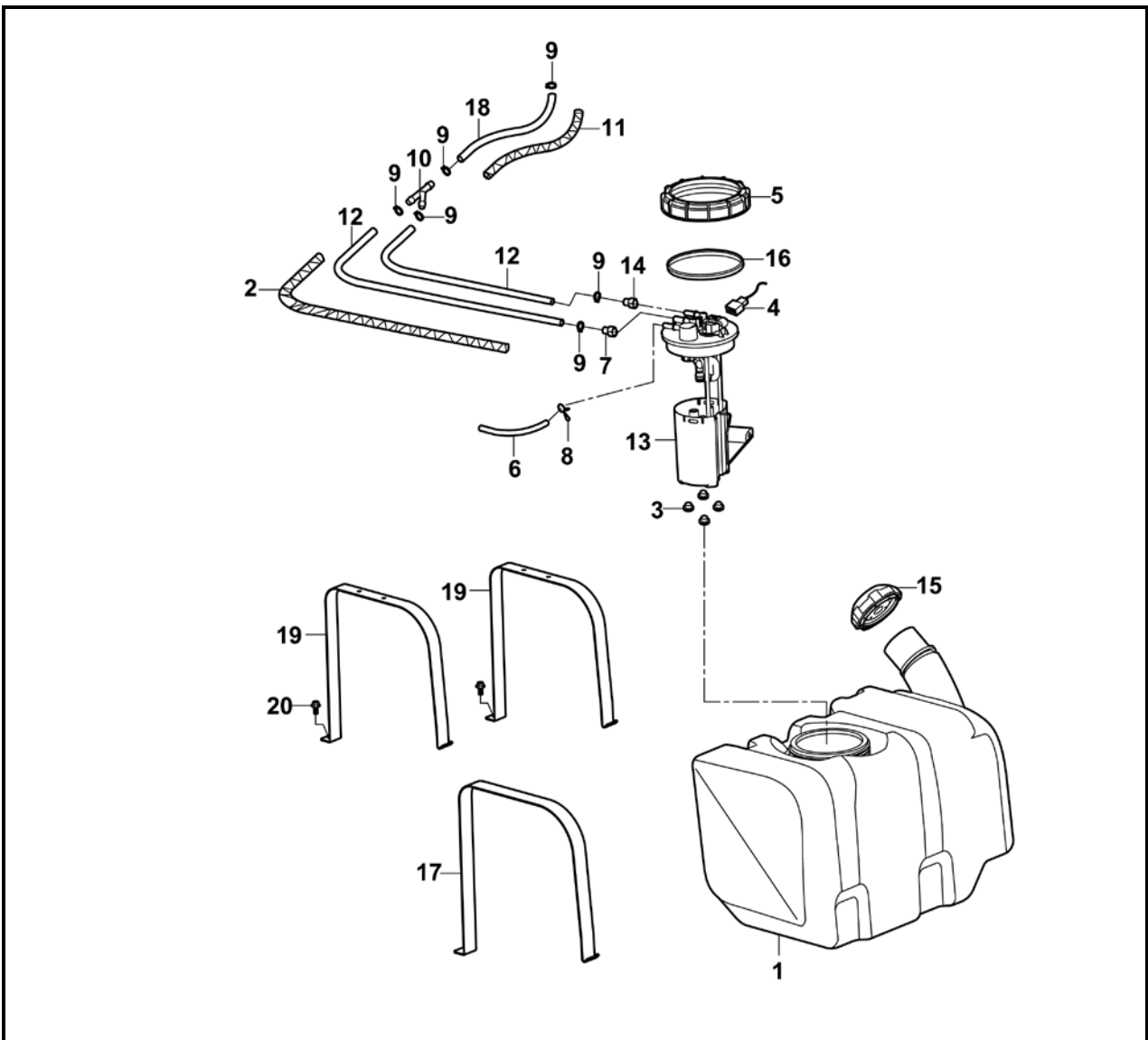

No.	Part Name	Qty	Remarks
12	Fuel pipe $\Phi 8 \times \Phi 14-250$	2	
13	Fuel pump assy	1	
14	Fuel inlet plug	1	
15	Fuel tank cap	1	
16	Seal gasket for fuel pump	1	
17	Cushion strip for fuel tank binder plate	2	
18	Fuel pipe $\Phi 8 \times \Phi 14-250$	1	
19	Binder plate for fuel tank	2	
20	Hexagon flange bolt M8×30	2	

## CHASSIS

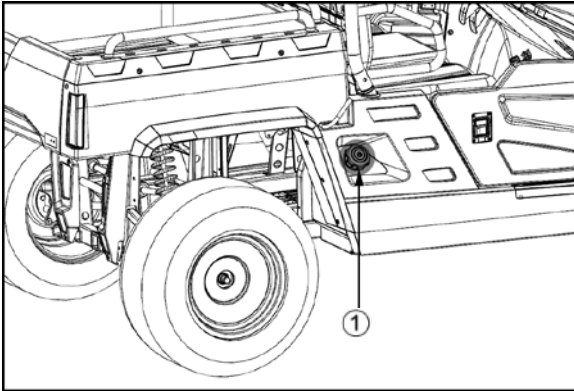

- Fuel tank cap

Remove the fuel tank cap by turning it counterclockwise.

Fill fuel tank when fuel gauge shows 1/4 or less fuel in tank.

**CAUTION:** \_\_\_\_\_

- **Do not smoke while refueling.**
- **Be sure to stop the engine before refueling.**

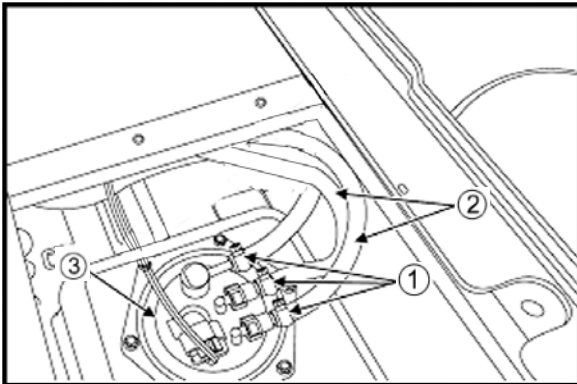

- Fuel pump

Pipe clamp ①

Fuel line ②

Fuel pump ③

**NOTE:** \_\_\_\_\_

When the fuel line is disconnected for maintenance or repair close both ends of the fuel line with a piece of clean cloth or paper to prevent dust and dirt from entering in addition particular, care must be taken not to admit dust and dirt into the fuel pump entrance of even a small amount of dust or dirt cause premature wear and malfunction of the fuel pump and injector components.

## ELECTRICAL COMPONENTS

### ELECTRICAL SYSTEM MALFUNCTION INSPECTION

S/N	Phenomenon	Measure
1	Abnormal lights	1、 Check whether switches normal.
		2、 Check whether cables damaged.
		3、 Check whether lights damaged.
2	Fail to shift into four-wheel-drive or lock differential.	1、 Check whether four wheel drive switch normal.
		2、 Check whether front bridge differential mechanical conversion agency locked or damaged.
3	Fail to electric start	1、 Check whether battery undercharge.
		2、 Check whether starting motor damaged.
		3、 Check whether EFI damaged.
		4、 Check whether ignition coil normal.
		5、 Check whether spark plug fouling or ablative.
		6、 Check whether crankshaft speedmeter magneto ignition signal normal.
		7、 Check whether oilpump damaged.
		8、 Check whether air filter plugged.
		9、 Check whether oil circuit smooth.
4	Abnormal speed indication between meter and mileage.	1、 Check whether speedmeter damaged.
		2、 Check whether meter damaged.
		3、 Check whether speedmeter surface polluted by iron scrap,
5	Neutral indicator of meter is not bright	1、 Check whether neutral switch damaged.
		2、 Check whether meter damaged.
		3、 Check whether cable damaged.
6	Reverse indicator of meter is not bright	1、 Check whether reverse switch damaged.
		2、 Check whether meter damaged.
		3、 Check whether cable damaged.
7	Other indicators of meter are not bright	1、 Check whether meter damaged.
		2、 Check whether cable damaged.
		3、 Check whether sensor or switch damaged.

# ELECTRICAL COMPONENTS

## ELECTRICAL

### ELECTRICAL COMPONENTS(bucket seat)

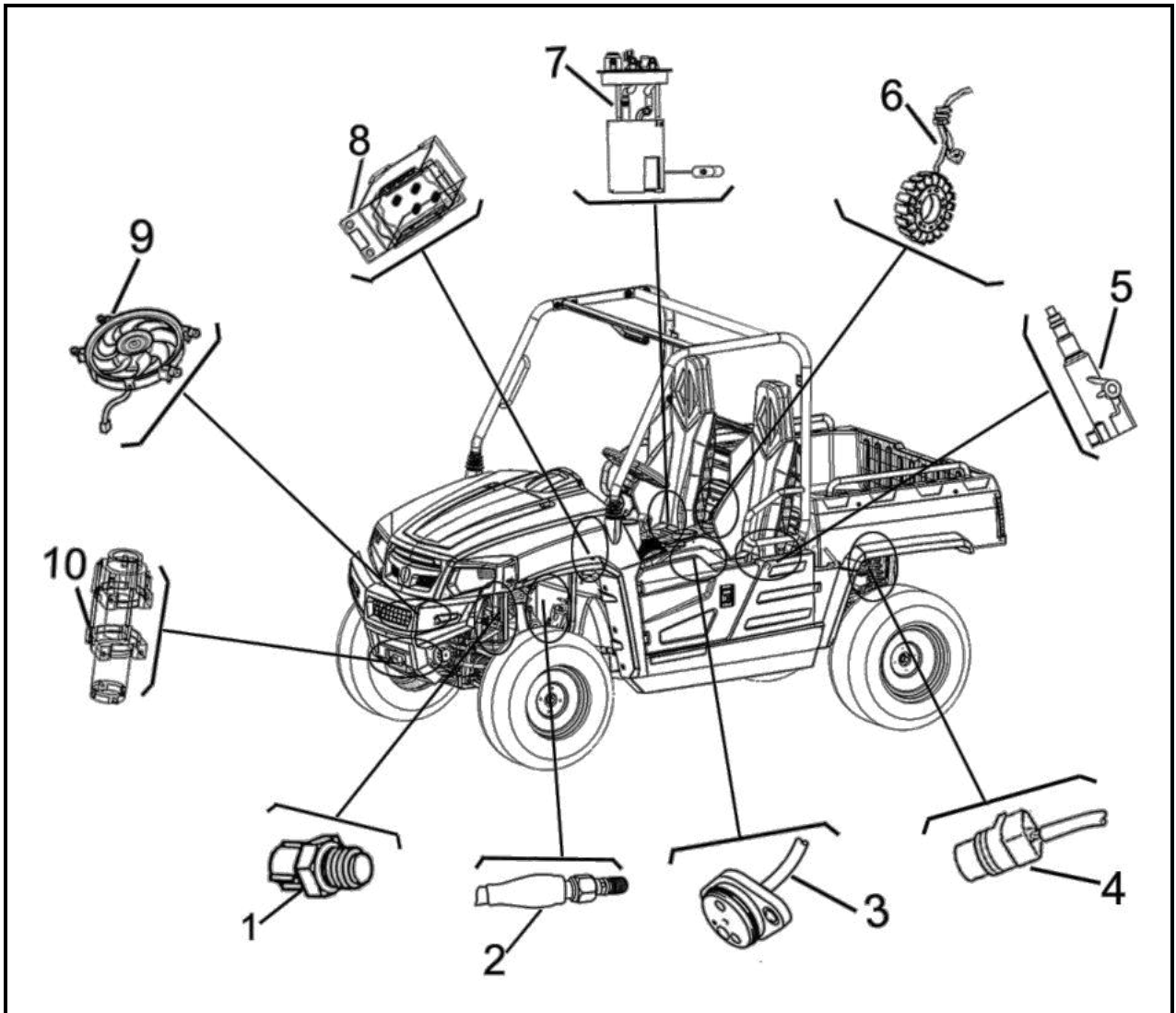

- |                         |
|-------------------------|
| 1. Thermo switch        |
| 2. Brake light switch   |
| 3. Gear position switch |
| 4. Speed sensor         |
| 5. Ignition coil        |
| 6. stator assembly      |
| 7. Fuel pump            |
| 8. Windlass controller  |
| 9. Radiator fan         |
| 10. Windlass            |

## ELECTRICAL COMPONENTS

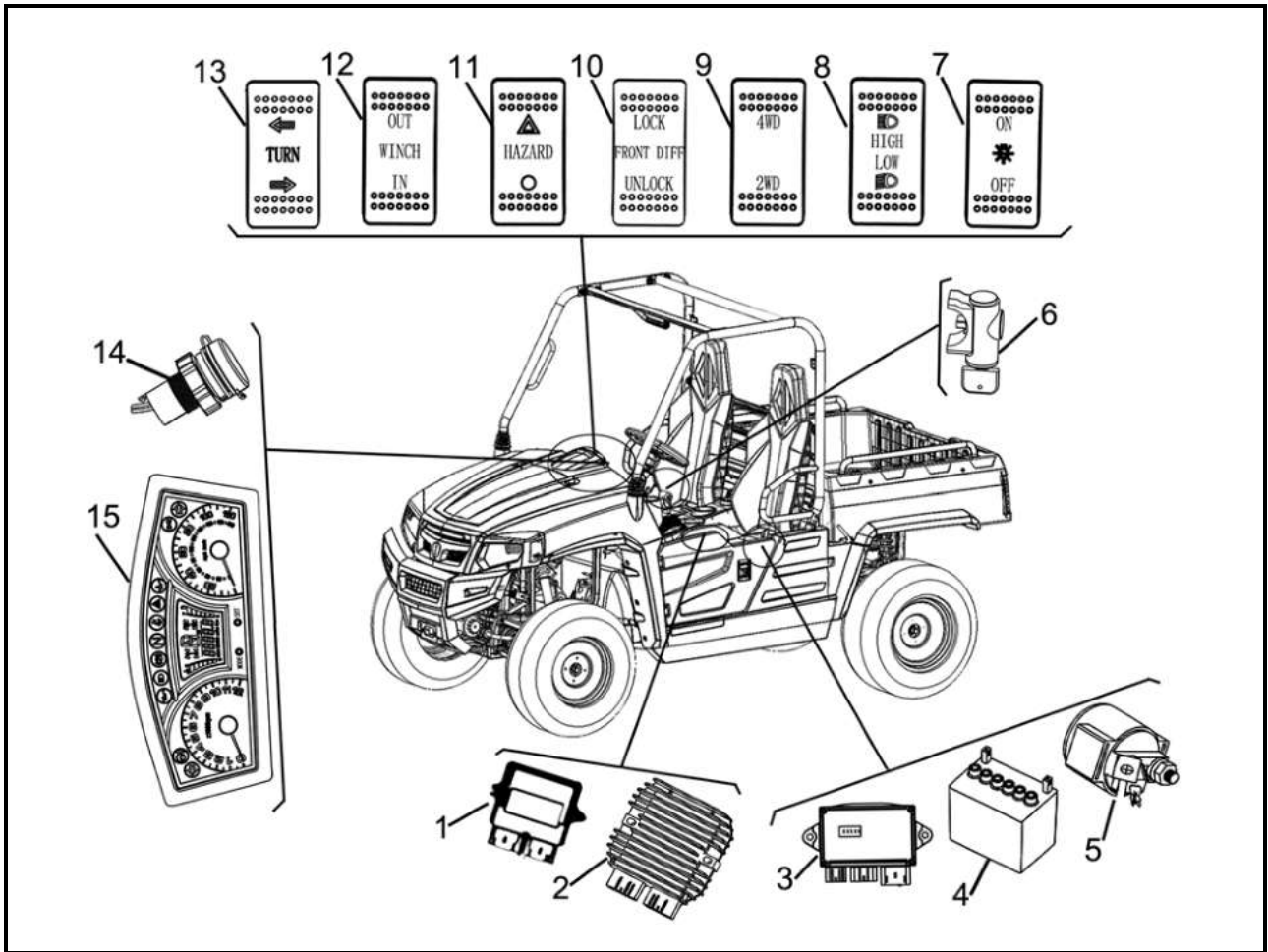

1. ECU unit
2. Rectifier/regulator
3. Relay assy.
4. Battery
5. Starter relay
6. Ignition switch parts
7. Lighting switch
8. Low (hight beam) convert switch
9. Driven switch assy.
10. Rear bridge differential convert switch
11. Emergency lamp switch
12. Windlass controller switch
13. Left(Right) turn controller switch
14. DC socket
15. Speedmeter

# ELECTRICAL COMPONENTS

## ELECTRICAL

### ELECTRICAL COMPONENTS (bench seat)

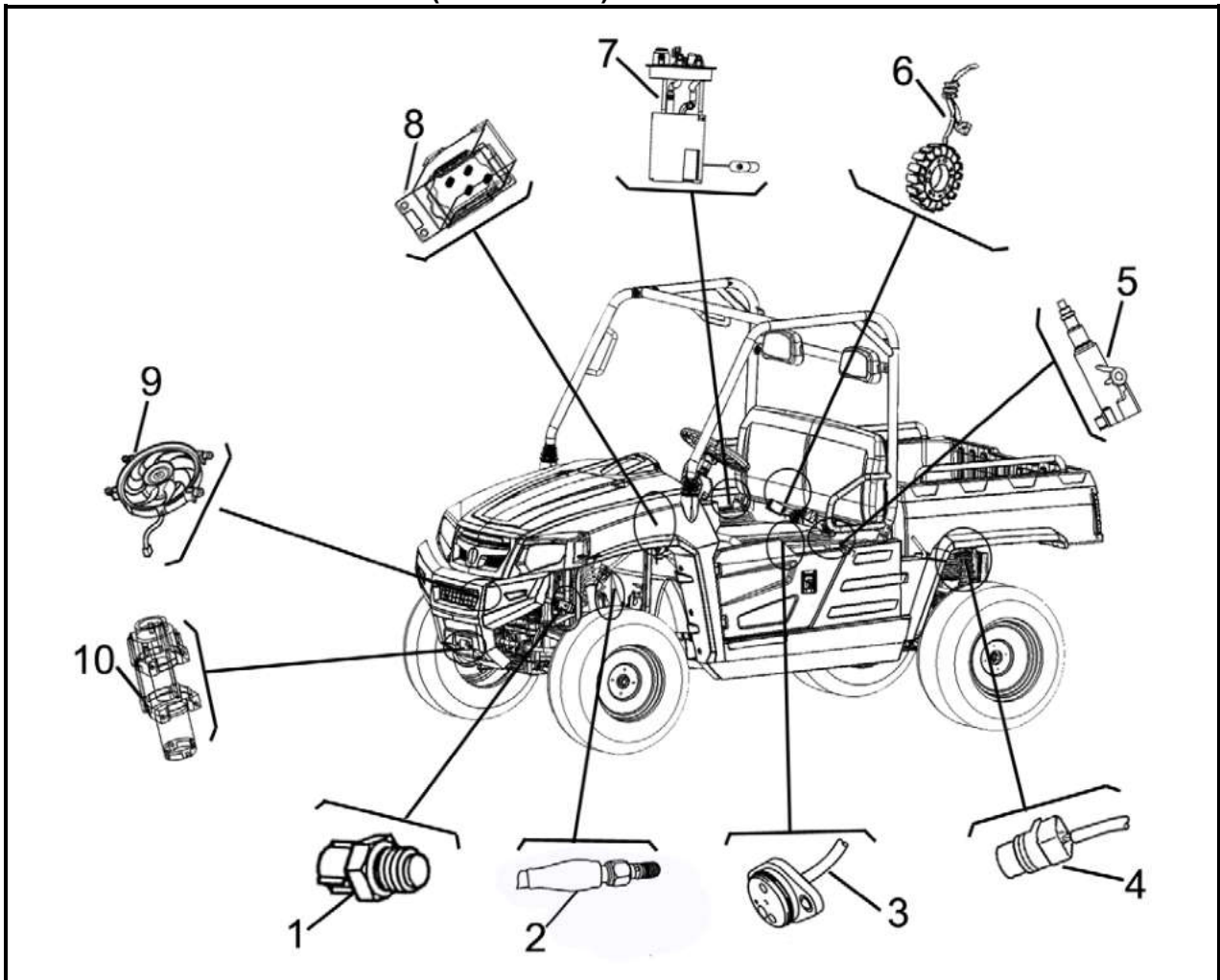

- |                         |
|-------------------------|
| 1. Thermo switch 1      |
| 2. Brake light switch   |
| 3. Gear position switch |
| 4. Speed sensor         |
| 5. Ignition coil        |
| 6. stator assembly      |
| 7. Fuel pump            |
| 8. Windlass controller  |
| 9. Radiator fan         |
| 10. Windlass            |

## ELECTRICAL COMPONENTS

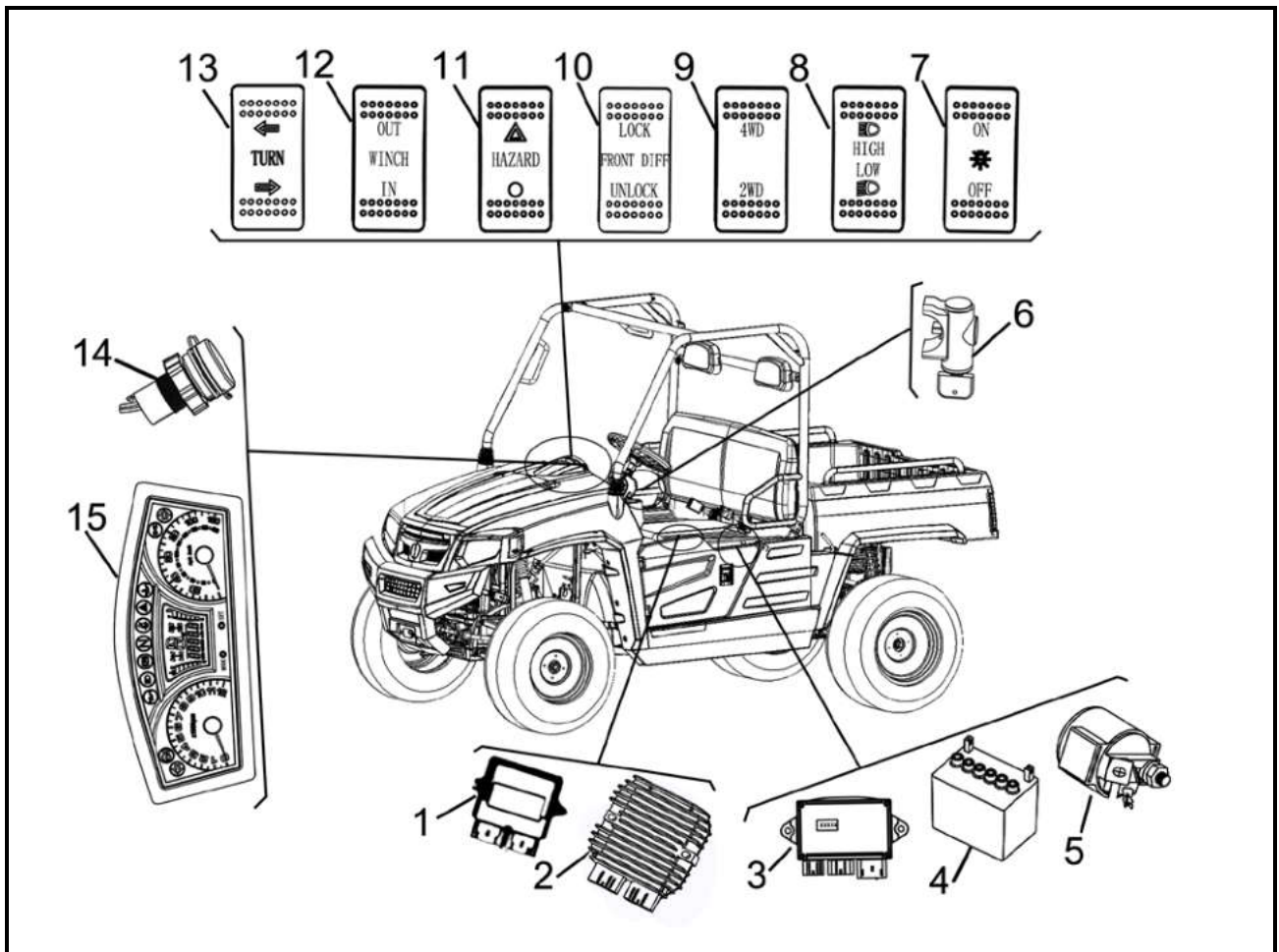

1. ECU unit
2. Rectifier/regulator
3. Relay assy.
4. Battery
5. Starter relay
6. Ignition switch parts
7. Lighting switch
8. Low (high beam) convert switch
9. Driven switch assy.
10. Rear bridge differential convert switch
11. Emergency lamp switch
12. Windlass controller switch
13. Left(Right) turn controller switch
14. DC socket
15. Speedmeter



# ELECTRICAL COMPONENTS

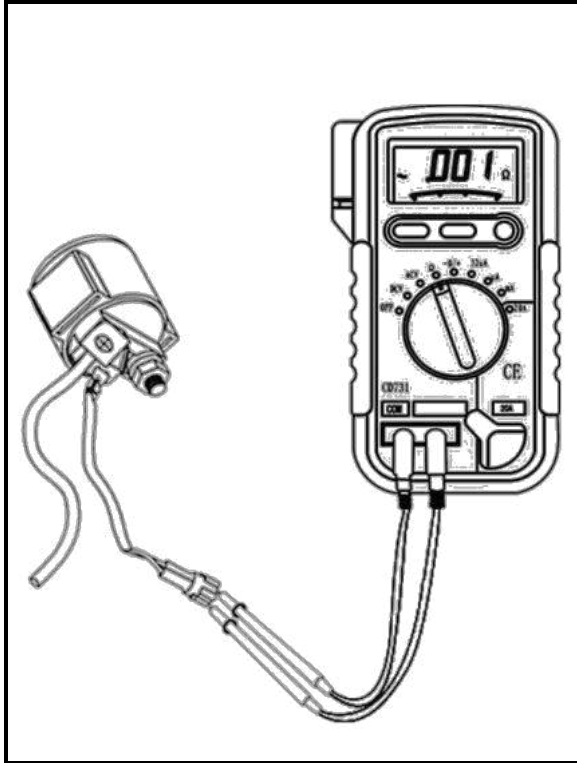

## CHECKING THE SWITCH

### CHECKING THE SWITCH

Use multimeter to check the terminals for continuity. If the continuity is faulty at any point, replace the switch.

#### NOTE:

- When the power supply is opened, should the multimeter gear to 200 Ω , digital watch LCD display.

A about  $4.4 \pm 0.3 \Omega$  in normal operations

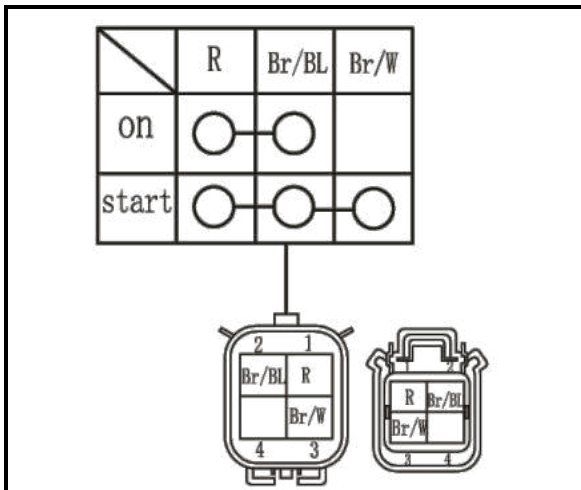

The terminal connections for switches (main switch, light switch, etc.) are shown in a chart similar to the one on the left. This chart shows the switch positions in the column and the switch lead colors in the top row.

For each switch position, “○—○” indicates the terminals with continuity.

#### The example chart shows that:

- ① There is continuity between the “Red and Brown/Blue” leads when the switch is set to “ON”.

# ELECTRICAL COMPONENTS

## Checking the switch continuity(bucket)

Refer to "CHECKING THE SWITCH" and check for continuity between lead terminals. Poor connection, no continuity → Correct or replace.

\* The coupler locations are circled.

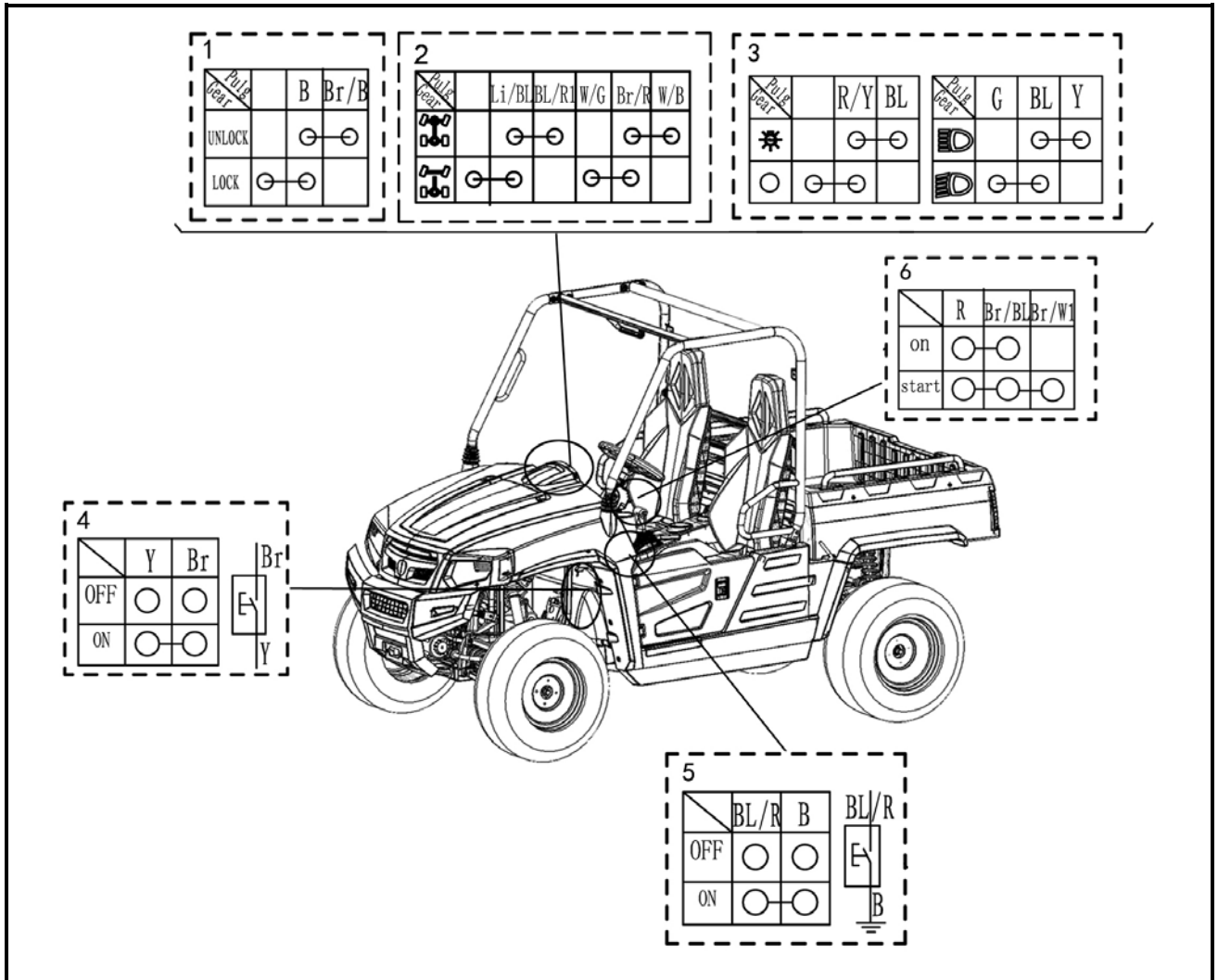

- |  |
|--|
| 1. Rear bridge differential gear lock switch |
| 2. Driven switch assy.                       |
| 3. Light switch                              |
| 4. Brake switch                              |
| 5. Parking switch                            |
| 6. Main switch                               |

# ELECTRICAL COMPONENTS

## Checking the switch continuity(bench)

Refer to "CHECKING THE SWITCH" and check for continuity between lead terminals. Poor connection, no continuity → Correct or replace.

\* The coupler locations are circled.

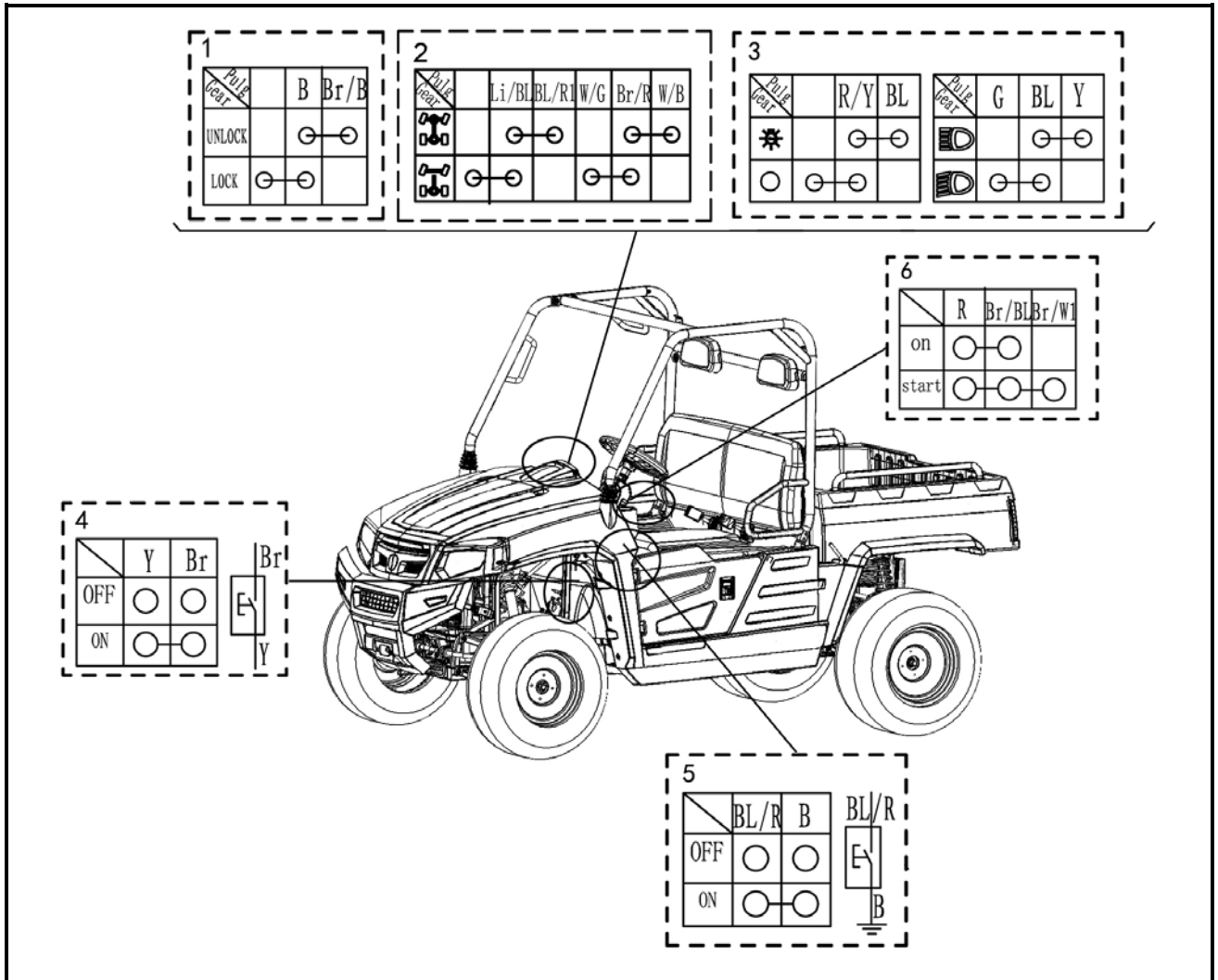

1. Rear bridge differential gear lock switch
2. Driven switch assy.
3. Light switch
4. Brake switch
5. Parking switch
6. Main switch

## ELECTRICAL COMPONENTS

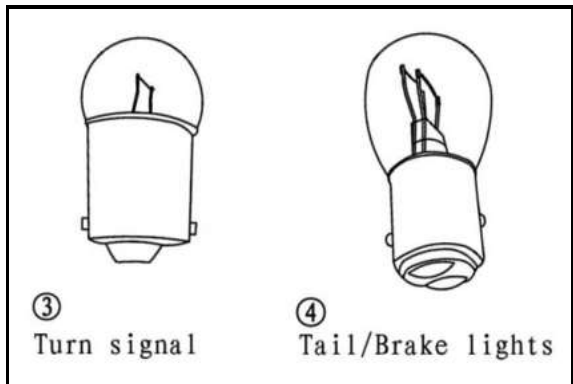
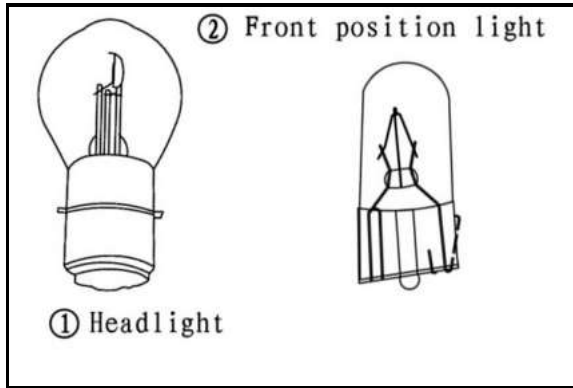

### CHECKING THE BULBS AND BULB SOCKETS

Check each bulb and bulb socket for damage or wear, proper connections, and also for continuity between the terminals

Damage/wear → Repair or replace the bulb, bulb socket or both.

Improperly connected → Properly connect.

Incorrect continuity reading → Repair or replace the bulb, bulb socket or both.

#### **WARNING:**

Since the bulb gets extremely hot, keep flammable products and your hands away from the bulb until it has cooled down.

#### **CAUTION:**

- Be sure to hold the socket firmly when removing the bulb. Never pull the lead, otherwise it may be pulled out of the terminal in the coupler.
- Avoid touching the glass part of the bulb to keep it free from oil, otherwise the transparency of the glass, the life of the bulb and the luminous flux will be adversely affected. If the bulb gets soiled, thoroughly clean it with a cloth moistened with alcohol or lacquer thinner.

### IGNITION SYSTEM

CIRCUIT DIAGRAM (see 442 page)

# ELECTRICAL COMPONENTS

## TROUBLESHOOTING

### IF THE IGNITION SYSTEM FAILS TO OPERATE (NO SPARK OR INTERMITTENT SPARK):

#### Procedure

Check:

1. Fuses (main, ignition)
2. Battery
3. Spark plug
4. Ignition spark gap
5. Spark plug cap resistance
6. Ignition coil resistance
7. Main switch
8. Pickup coil resistance
9. Wiring connection (the entire ignition system)

#### NOTE:

1. Cushion
2. Front frame
3. Front fender

Check and repair with following special tools.

1. Fuses (main, ignition)

Refer to "CHECKING THE SWITCH".

NO CONTINUITY

CONTINUITY

Replace the fuse(s).

2. Battery

- Check the battery condition. Refer to "CHECKING AND CHARGING THE BATTERY" in chapter 3.

**Open-circuit voltage**

**12.8 V or more at 20 °C (68 °F)**

INCORRECT

- Clean the battery terminals.
- Recharge or replace the battery.

CORRECT

3. Spark plug

- Check the spark plug condition.
  - Check the spark plug type.
  - Check the spark plug gap.
- Refer to "CHECKING THE SPARK PLUG" in chapter 3.

# ELECTRICAL COMPONENTS

## 4. Ignition spark gap

- Disconnect the spark plug cap from the spark plug.
- Connect the pulse ignition spark checker or ignition checker ① as shown.

### ② Spark plug cap

- Turn the main switch to "ON".
- Check the ignition spark gap ②.
- Crank the engine by pushing the starter switch, and increase the spark gap until a misfiring occurs.

### Minimum spark gap

**6.0 mm (0.24 in)**

OUT OF SPECIFICATION OR  
NO SPARK

INCORRECT

Repair or replace the spark plug.

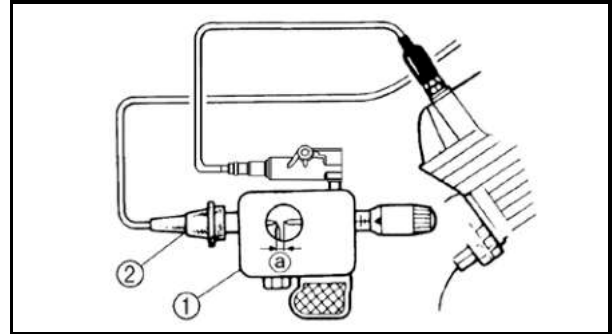

MEETS SPECIFICATION

The ignition system is not faulty.

## 5. Spark plug cap resistance

- Remove the spark plug cap.
- Connect the pocket tester ( $\Omega \times 1k$ ) to the spark plug cap.
- Check that the spark plug cap has the specified resistance.

### Spark plug cap resistance

**10 k $\Omega$  at 20 °C (68 °F)**

MEETS SPECIFICATION

OUT OF SPECIFICATION

Replace the spark plug cap.

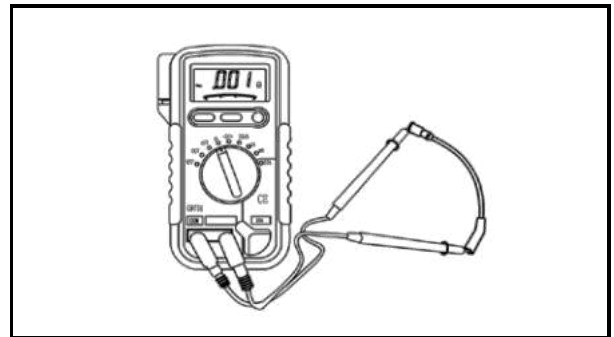

## 6. Ignition coil resistance

- Disconnect the ignition coil connector from the wire harness
- Connect the pocket tester ( $\Omega \times 1$ ) to the ignition coil.

**Tester (+) lead → Orange lead terminal**

**Tester (-) lead → Ignition coil base**

- Check that the primary coil has the specified

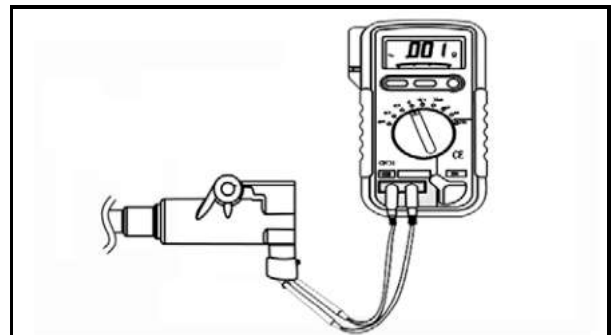

# ELECTRICAL COMPONENTS

. resistance

## Primary coil resistance

**0.18 ~ 0.28  $\Omega$  at 20 °C (68 °F)**

- Connect the pocket tester ( $\Omega \times 1k$ ) to the ignition coil.

**Tester (+) lead → Orange lead terminal**

**Tester (-) lead → Spark plug lead**

- Check that the secondary coil has the specified resistance.

## Secondary coil resistance

**6.32 ~ 9.48 k $\Omega$  at 20 °C (68 °F)**

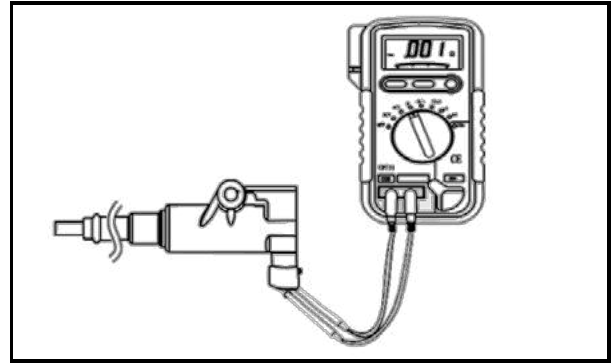

OUT OF SPECIFICATION

Replace the ignition coil.

BOTH MEET SPECIFICATION

## 7. Main switch

Refer to "CHECKING THE SWITCH"

INCORRECT

Replace the main switch.

CORRECT

## 8. Pickup coil resistance

- 0• Disconnect the A.C. magneto coupler from the wire harness.

- Connect the pocket tester ( $\Omega \times 100$ ) to the pickup coil terminal.

**Tester (+) lead → White/ Blue terminal ①**

**Tester (-) lead → Green terminal ②**

- Check the pickup coil for the specified resistance.

## Pickup coil resistance

**459 ~ 561  $\Omega$  at 20 °C (68 °F)**

**(White/Red – White/Green)**

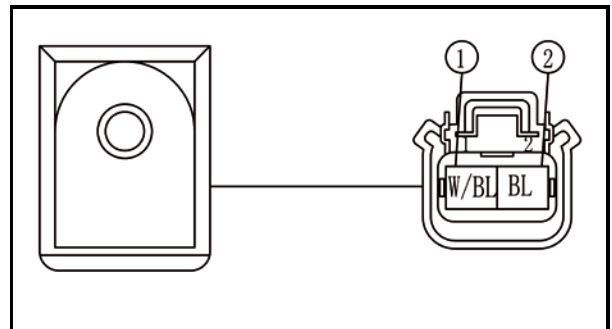

OUT OF SPECIFICATION

Replace the pickup coil/stator assembly.

MEETS SPECIFICATION

# ELECTRICAL COMPONENTS

---

## 9. Wiring connection

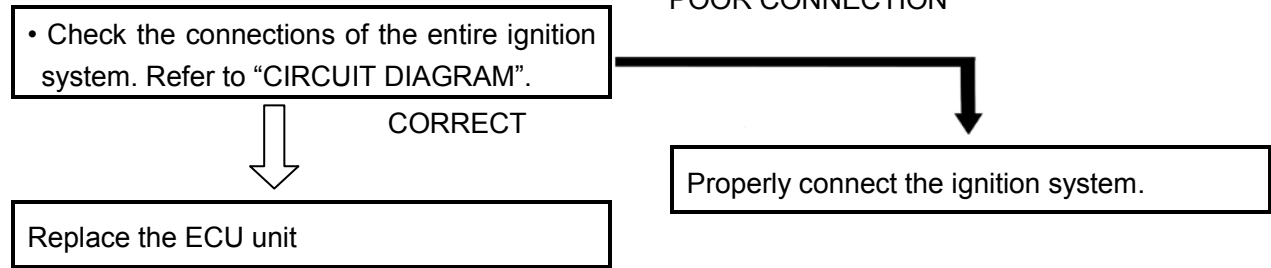

**ELECTRIC STARTING SYSTEM**  
**CIRCUIT DIAGRAM (see 442 page)**



# ELECTRICAL COMPONENTS

## TROUBLESHOOTING

### IF THE STARTER MOTOR FAILS TO OPERATE:

#### Procedure

Check:

1. Fuses (main, ignition, signaling system)
2. Battery
3. Starter motor
4. Starter relay
5. Main switch

6. Gear position switch
7. Brake light switch
8. Diode 1
9. Wiring connection (the entire starting system)

#### NOTE:

- Remove the following part(s) before troubleshooting:

1. Console
2. Front frame
3. Front fender

- Use the following special tool(s) for troubleshooting.

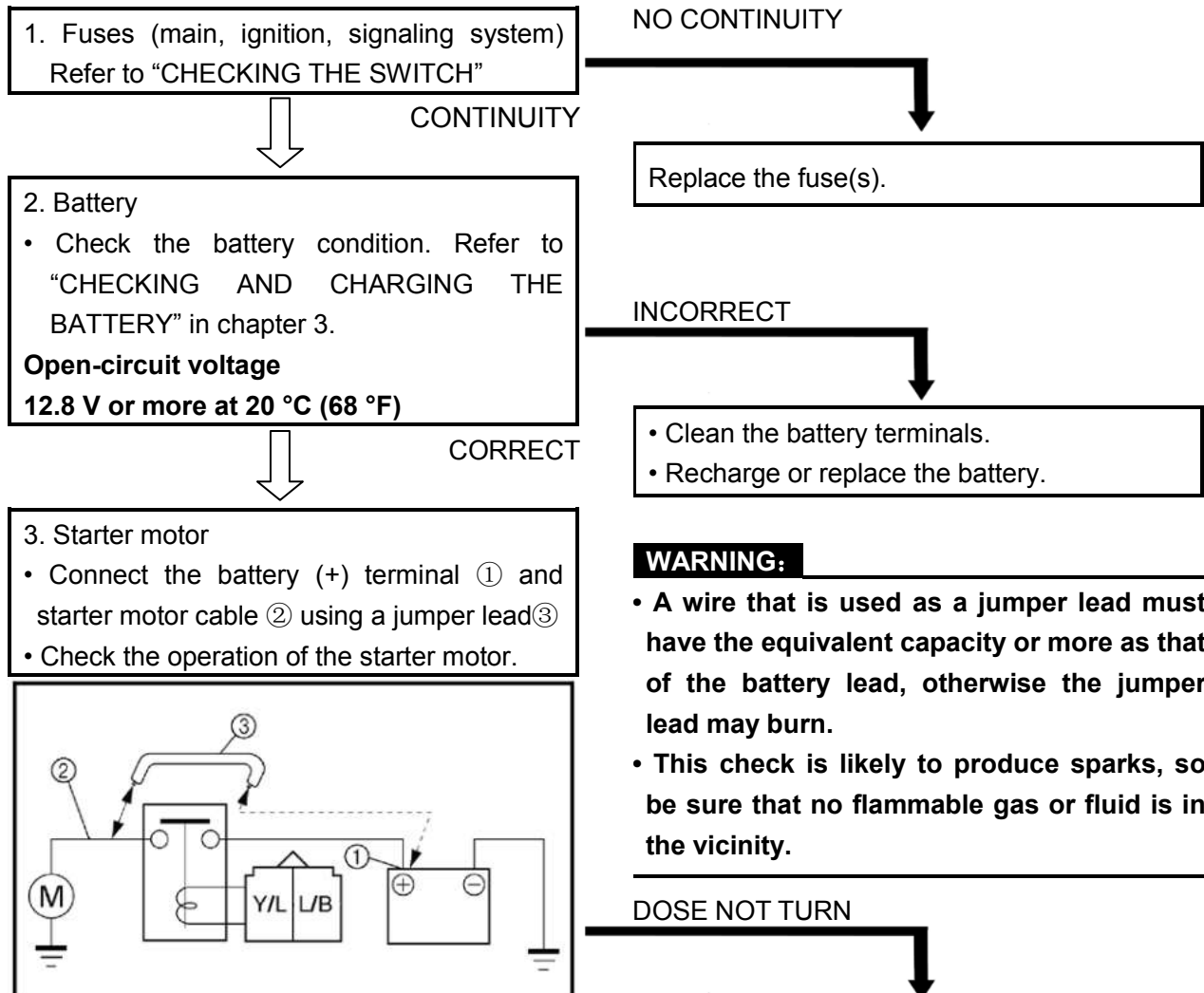

# ELECTRICAL COMPONENTS

↓ TURNS

4. Starter relay

- Remove the starter relay from the wire harness.
- Connect the pocket tester ( $\Omega \times 1$ ) and the battery (12 V) to the starter relay terminals.

**Battery (+) terminal → Yellow/Blue terminal ①**

**Battery (-) terminal → Blue/Black terminal ②**

**Tester (+) lead → Red terminal ③**

**Tester (-) lead → Black terminal ④**

- Check the starter relay for continuity.

Repair or replace the starter motor.

Small testers and battery and (12V) and start relay terminal connection

Check continuity of the start relay

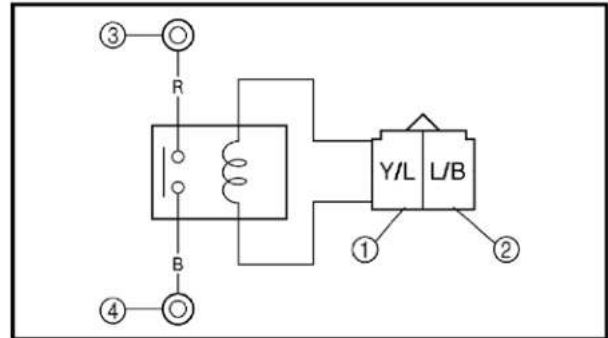

↓ CONTINUITY

5. Main switch Refer to "CHECKING THE SWITCH".

↓ CORRECT

6. Gear position switch Refer to "CHECKING THE SWITCH".

↓ CORRECT

7. Brake light switch Refer to "CHECKING THE SWITCH".

↓ CORRECT

8. Diode 1

(-) Connect multimeter positive to Yellow/Red green terminal (1)

Connect multimeter negative to Black/Light blue ② or blue red ③ terminal (2)

NO CONTINUITY

Replace the starter relay.

INCORRECT

Replace the main switch.

INCORRECT

Replace the gear position switch.

INCORRECT

Replace the brake light switch.

Removed from the coupling diodes

Small diode Tester connection terminals, As shown in the figure

Check the diode continuity

# ELECTRICAL COMPONENTS

**NOTE:**

1. When you switch the tester's positive and negative probes, the readings in the left chart will be reversed.

(⇐) Connect multimeter positive to Red/Blue white terminal (1)  
 Connect multimeter negative to Yellow/Blue terminal (2)

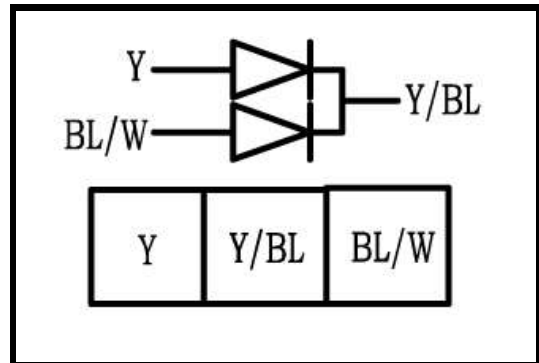
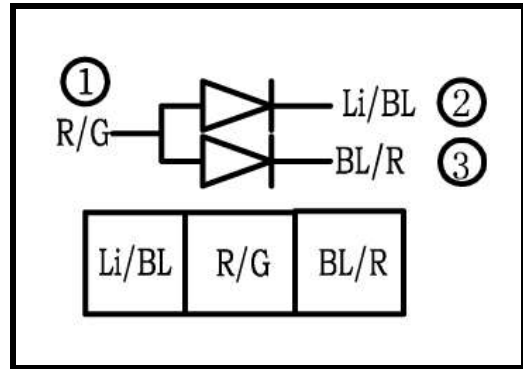

**NOTE:**

2. When you switch the tester's positive and negative probes, the readings in the left chart will be reversed.

↓ CORRECT

9. Wiring connection  
 • Check the connections of the entire starting system. Refer to "CIRCUIT DIAGRAM".

POOR CONNECTION

Properly connect the starting system.

# ELECTRICAL COMPONENTS

## STARTER MOTOR

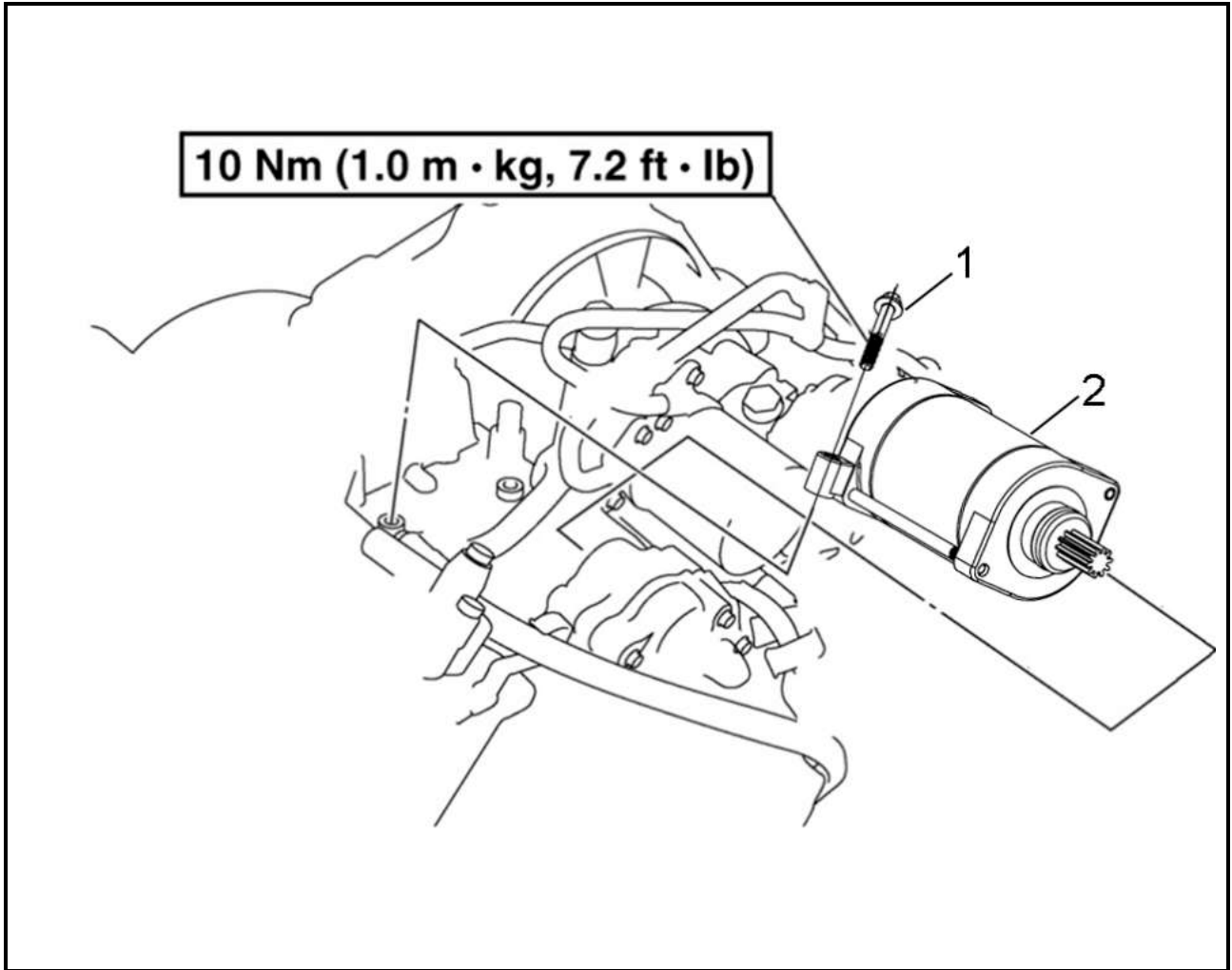

No.	Part Name	Qty	Remarks	The performance parameters
	<b>Removing the starter motor</b>	1	Remove the parts in the order listed	1、 no-load : 12V/300W
1	Flange bolt			2、 Load : 12V/1400W
2	Starter motor assy.			3、 The load torque:1.2N.m

# ELECTRICAL COMPONENTS

## CHARGING SYSTEM CIRCUIT DIAGRAM

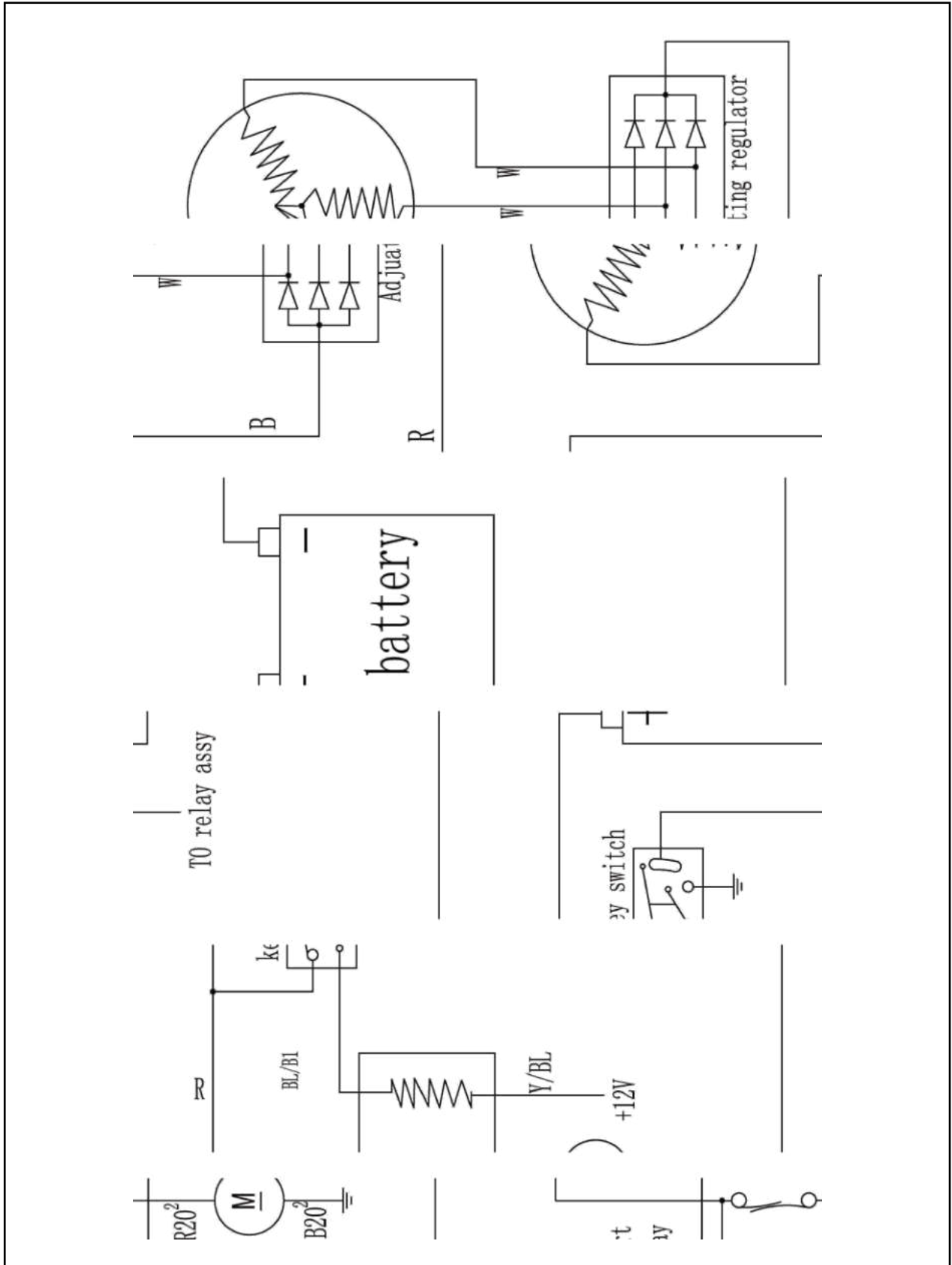

# ELECTRICAL COMPONENTS

## TROUBLESHOOTING

### IF THE BATTERY IS NOT CHARGED:

1. Fuse (main)
2. Battery
3. Charging voltage

4. Charging coil resistance
5. Wiring connections(the entire charging system)

#### **NOTE:**

Remove some parts before maintenance

#### 1. Cushion

Repair with following special toolings

1. Fuse (main)

Refer to "CHECKING THE SWITCH".

CONTINUITY

NO CONTINUITY

Replace the fuse.

2. Battery

• Check the battery condition. Refer to "CHECKING AND CHARGING THE BATTERY in chapter 3.

#### Open-circuit voltage

12.8 V or more at 20 °C (68 °F)

CORRECT

INCORRECT

- Clean the battery terminals.
- Recharge or replace the battery.

3. Charging voltage

- Connect the engine tachometer to the spark plug lead.
- Connect the pocket tester (DC 20 V) to the battery.

Tester (+) lead → Battery (+) terminal

Tester (-) lead → Battery (-) terminal

- Start the engine and accelerate to about 1,000 r/min.

Charging voltage 14 V at 1,450 r/min

#### **NOTE:**

Use a fully charged battery.

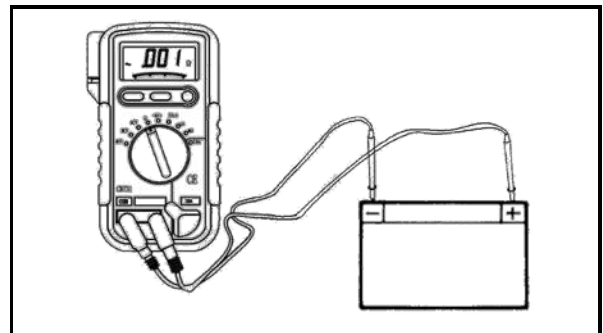

MEETS SPECIFICATION

The charging circuit is not faulty.

OUT OF SPECIFICATION

# ELECTRICAL COMPONENTS

## 4. Charging coil resistance

- Disconnect the A.C. magneto coupler from the wire harness.
- Connect the pocket tester ( $\Omega \times 1$ ) to the charging coils.

**Tester (+) lead → White terminal ①**

**Tester (-) lead → White terminal ②**

**Tester (+) lead → White terminal ①**

**Tester (-) lead → White terminal ③**

- Measure the charging coil resistance.

**Charging coil resistance**

**0.32 ~ 0.43  $\Omega$  at 20 °C (68 °F)**

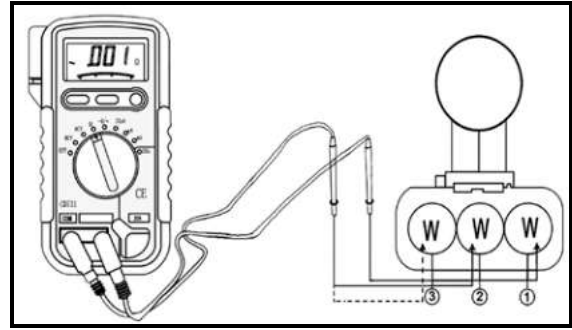

MEETS SPECIFICATION

OUT OF SPECIFICATION

Replace the pickup coil/stator assembly.

## 5. Wiring connections

- Check the connections of the entire charging system. Refer to "CIRCUIT DIAGRAM".

CORRECT

POOR CONNECTION

Replace the rectifier/regulator.

Properly connect the charging system.

## LIGHTING SYSTEM

**CIRCUIT DIAGRAM (see 442 page)**

# ELECTRICAL COMPONENTS

## TROUBLESHOOTING

**IF THE HEADLIGHT AND/OR TAILLIGHT FAIL TO COME ON:**

### Procedure

Check

1. Fuses (main, lighting system)
2. Battery
3. Main switch
4. Light switch
5. Wiring connections(the entire lighting system)

### NOTE:

• Remove the following part(s) before troubleshooting:

1. Console
2. Front luggage carrir
3. Front covering parts

• Use special tool(s) for troubleshooting.

1. Fuses (main, lighting system)

Refer to "CHECKING THE SWITCH".

NO CONTINUITY



CONTINUITY

2. Battery

• Check the battery condition. Refer to "CHECKING AND CHARGING THE BATTERY" in chapter 3.

**Open-circuit voltage**

**12.8 V or more at 20 °C (68 °F)**

Replace the fuse(s).

INCORRECT



CORRECT

3. Main switch

Refer to "CHECKING THE SWITCH".

• Clean the battery terminals.

• Recharge or replace the battery

INCORRECT



CORRECT

4. Light switch

Refer to "CHECKING THE SWITCH".

Replace the main switch.

INCORRECT



CORRECT

5. Wiring connection

• Check the connections of the entire lighting system. Refer to "CIRCUIT DIAGRAM".

Replace the light switch.

POOR CONNECTION



CORRECT

Check the condition of each of the lighting system's circuits. Refer to "CHECKING THE LIGHTING SYSTEM".

Properly connect the lighting system.



# ELECTRICAL COMPONENTS

## CHECKING THE LIGHTING SYSTEM

### 1. If the headlights fail to come on:

#### (1). Bulb and bulb socket

- Check the bulb and bulb socket for continuity.



CONTINUITY

#### (2). Voltage

- Connect the pocket tester (DC 20 V) to the headlight couplers.

**Tester (+) lead →**

**Black terminal ① or Yellow terminal ②**

**Tester (-) lead → Green terminal ③**

Ⓐ When the light switch is on "D".

Ⓑ When the light switch is on "L".

- Turn the main switch to "ON".
- Turn the light switch to "D" or "L".
- Check the voltage (12 V) of the "Green" and "Yellow" leads on the bulb socket connector.



MEETS SPECIFICATION

This circuit is not faulty.

NO CONTINUITY

Replace the bulb and/or bulb socket.

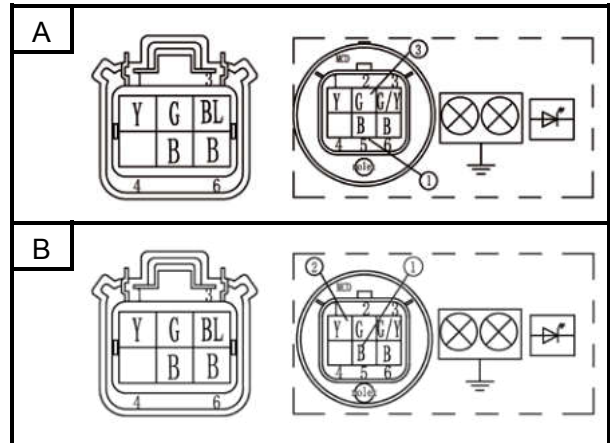

OUT OF SPECIFICATION

The wiring circuit from the main switch to the bulb socket connector is faulty, repair it.

# ELECTRICAL COMPONENTS

## 2. If the taillights fail to come on:

### (1). Bulb and bulb socket

- Check the bulb and bulb socket for continuity.

CONTINUITY

NO CONTINUITY



Replace the bulb and/or bulb socket.

### (2) . Voltage

- Connect the pocket tester (DC 20 V) to the tail/brake light couplers.

**Tester (+) lead → Yellow1 lead terminal ①**

**Tester (-) lead → Black lead terminal ②**

- Turn the main switch to “ON”.
- Turn the light switch to “ ” or “ ”.

- Check the voltage (12 V) of the “Blue” lead on the bulb socket connector.

MEETS SPECIFICATION

This circuit is not faulty.

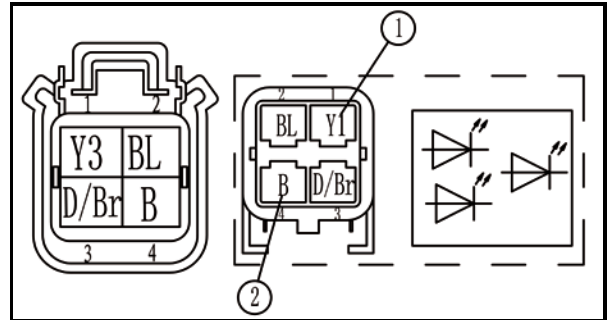

OUT OF SPECIFICATION

The wiring circuit from the main switch to the bulb socket connector is faulty, repair it.

## SIGNALING SYSTEM

CIRCUIT DIAGRAM (see 442 page)

# ELECTRICAL COMPONENTS

## TROUBLESHOOTING

**IF A BRAKE LIGHT, AN INDICATOR LIGHT, OR THE WARNING LIGHT FAILS TO COME ON:**

### Procedure

Check:

1. Fuses (main, signaling system)
2. Battery

3. Main switch

4. Wiring connections (the entire signal system)

### NOTE:

• Remove the following part(s) before troubleshooting:

1. Console
2. Front frame
3. Front pedal

• Use special tool(s) for troubleshooting.

1. Fuses (main, signaling system)

Refer to "CHECKING THE SWITCH".



CONTINUITY

2. Battery

• Check the battery condition. Refer to "CHECKING AND CHARGING THE BATTERY" in chapter 3.

**Open-circuit voltage**

**12.8 V or more at 20 °C (68 °F)**



CORRECT

3. Main switch

Refer to "CHECKING THE SWITCH".



CORRECT

4. Wiring connections

• Check the connections of the entire signal system. Refer to "CIRCUIT DIAGRAM".



CORRECT

Check the condition of each of the signal system's circuits. Refer to "CHECKING THE SIGNAL SYSTEM".

NO CONTINUITY

Replace the fuse(s).

INCORRECT

- Clean the battery terminals.
- Recharge or replace the battery.

INCORRECT

Replace the main switch

POOR CONNECTION

Properly connect the signal system.

# ELECTRICAL COMPONENTS

## CHECKING THE SIGNAL SYSTEM

### 1. If the brake lights fail to come on:

#### (1). Bulb and bulb socket

- Check the bulb and bulb socket for continuity.

CONTINUITY

NO CONTINUITY

Replace the bulb and/or bulb socket.

#### (2). Brake light switch

Refer to "CHECKING THE SWITCH".

CONTINUITY

NO CONTINUITY

Replace the brake light switch.

#### (3). Voltage

- Connect the pocket tester (DC 20 V) to the bulb socket connector.

**Tester (+) lead → Dark/Brown terminal ①**

**Tester (-) lead → Black terminal ②**

- Turn the main switch to "ON".
- Turn the light switch to "←" or "→".

- Check the voltage (12 V) of the "Yellow" lead on the bulb socket connector.

MEETS SPECIFICATION

This circuit is not faulty.

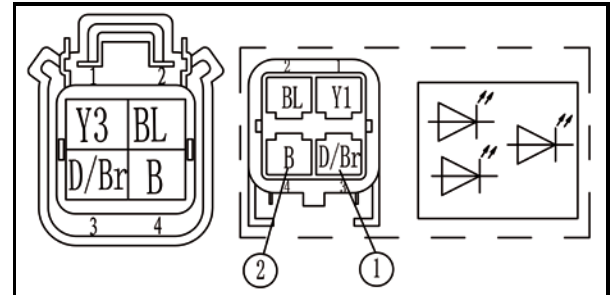

OUT OF SPECIFICATION

The wiring circuit from the main switch to the bulb socket connector is faulty, repair it.

# ELECTRICAL COMPONENTS

## 2. If L, H, N, R, light is not bright

### (1). Gear position switch

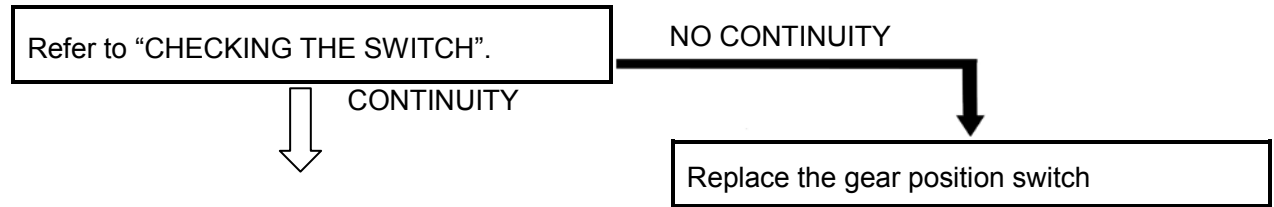

### (2). Wire connection

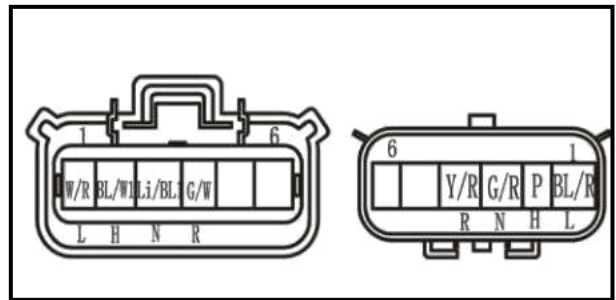
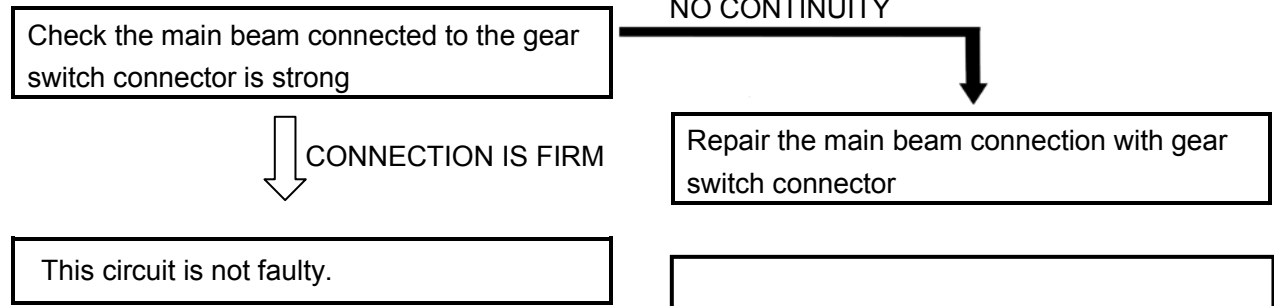

# ELECTRICAL COMPONENTS

## 3. If the parking brake indicator light fails to come on:

(1). Brake switch

Refer to "CHECKING THE SWITCH".

CONTINUITY

NO CONTINUITY

Replace the parking brake switch

(2). Voltage

Set the multimeter to DC12V, test the brake lamp voltage at both ends

Yellow3 power meter pens → ①

Black power meter pens → ②

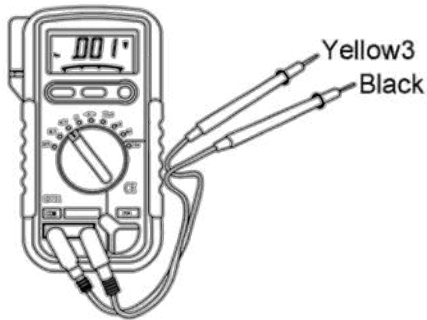

DISPLAY +12V

This circuit is not faulty.

NO VOLATGE DISPLAY

Replace the fuse F2

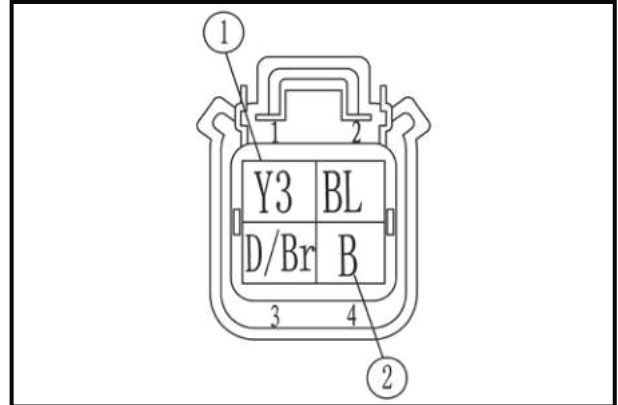

# ELECTRICAL COMPONENTS

## 4. If the reverse indicator light fails to come on:

(1). Directional signal switch

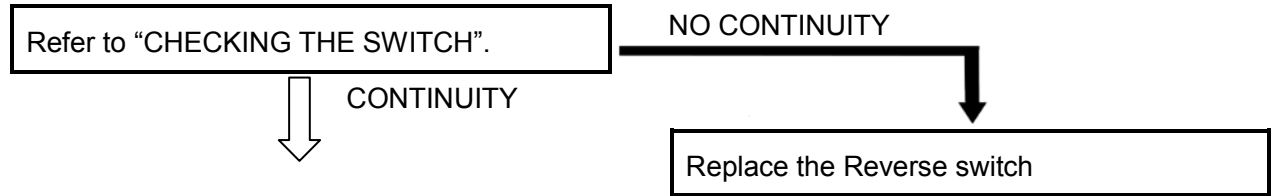

(2). Voltage

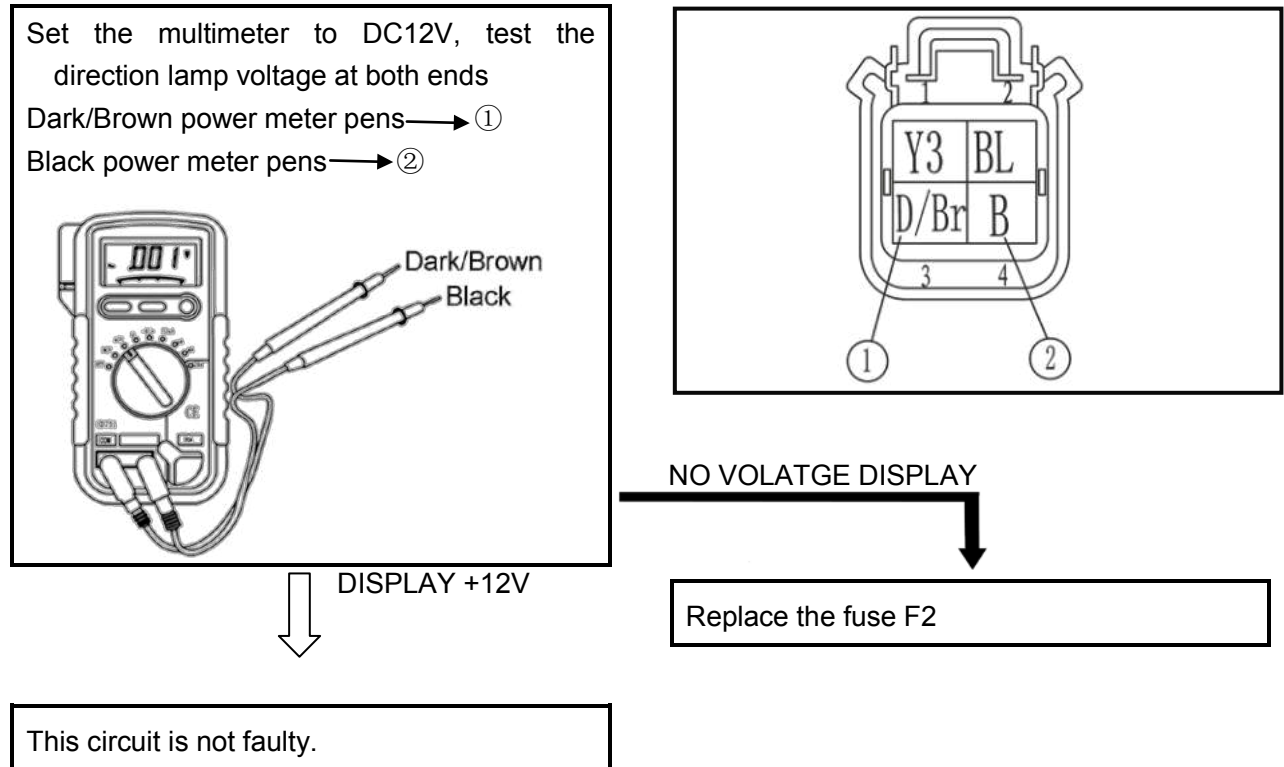

## ELECTRICAL COMPONENTS

5. If the coolant temperature warning light does not come on when the main switch to “ON”, or if the coolant temperature warning light does not come on when the temperature is high (more than 117 ~ 123 °C (242.6 ~ 253.4 °F):

(1). Bulb and bulb socket

- Check the bulb and bulb socket for continuity.

NO CONTINUITY

Replace the bulb and/or bulb socket.

(2). Thermo switch 1

CONTINUITY

- Remove the thermo switch 1 from the cylinder head.
  - Connect the pocket tester ( $\Omega \times 1$ ) to the thermo switch 1 ①.
  - Immerse the thermo switch 1 in coolant ②.
  - Check the thermo switch 1 for continuity.
- While heating the coolant use a thermometer ③ to record the temperatures.

Ⓐ The thermo switch 1 circuit is open and the coolant temperature warning light is off.

Ⓑ The thermo switch 1 circuit is closed and the coolant temperature warning light is on.

Test step	Coolant temperature	Continuity
1	Less than $120 \pm 3 \text{ }^\circ\text{C}$ ( $248 \pm 5.4 \text{ }^\circ\text{F}$ )	No
2	More than $120 \pm 3 \text{ }^\circ\text{C}$ ( $248 \pm 5.4 \text{ }^\circ\text{F}$ )	Yes
3	More than $113 \text{ }^\circ\text{C}$ ( $235.4 \text{ }^\circ\text{F}$ )	Yes
4	Less than $113 \text{ }^\circ\text{C}$ ( $235.4 \text{ }^\circ\text{F}$ )	No

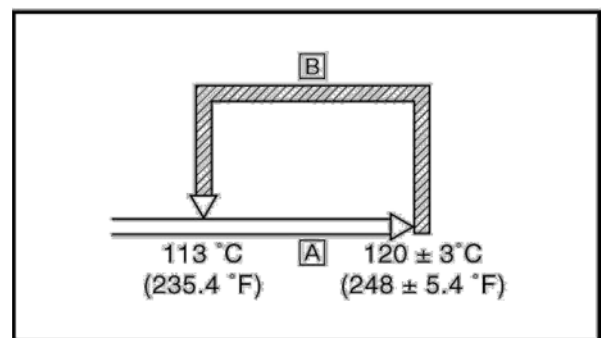
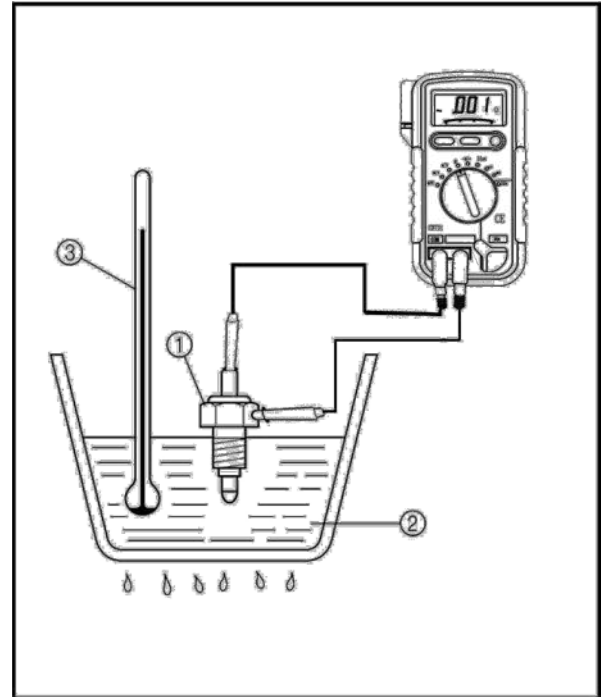

Test steps 1 & 2: Heating phase

Test steps 3 & 4: Cooling phase

**WARNING:**

Handle the thermo switch 1 with special care.

Never subject it to a strong shock or allow it to be dropped. Should it be dropped, it must be replaced.

BAD CONDITION

Replace the thermo switch 1



# ELECTRICAL COMPONENTS

6. If the four-wheel drive and front bridge differential lock indicator light fails to come on:

(1). Check the driver combination switch and front axle differential switch

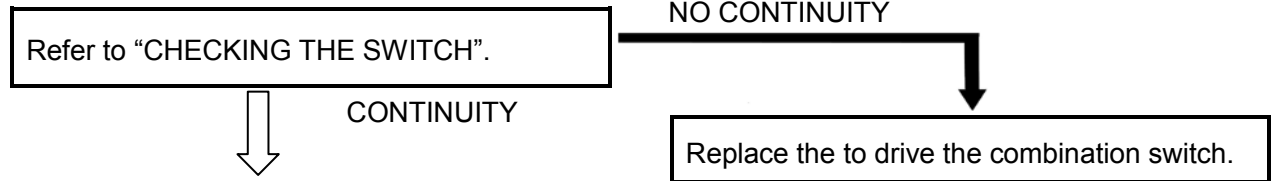

(2). Wire connection detection

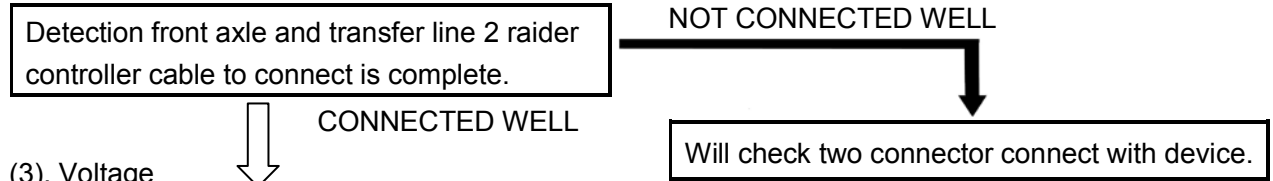

(3). Voltage

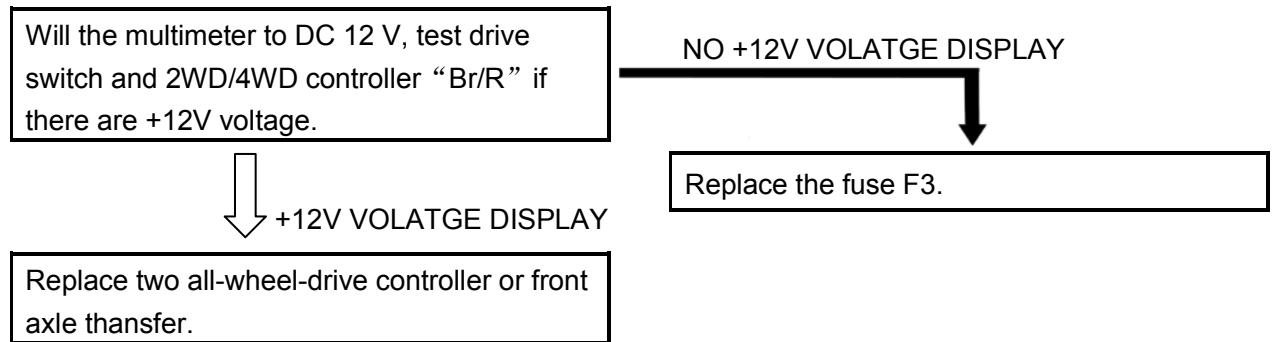

## ELECTRICAL COMPONENTS

---

### COOLING SYSTEM CIRCUIT DIAGRAM



# ELECTRICAL COMPONENTS

## TROUBLESHOOTING

### IF THE FAN MOTOR DOES NOT MOVE:

Procedure

Check:

1. Fuse (main)
2. Battery
3. Main switch
4. Radiator fan motor

5. Thermo switch 3

6. Wiring connection(the entire cooling system)

#### **NOTE:**

• Remove the following part(s) before troubleshooting.

1. Console
2. Front frame
3. Front pedal

• Use special tool(s) for troubleshooting.

1. Fuse (main)

Refer to "CHECKING THE SWITCH".

CONTINUITY  
↓

NO CONTINUITY

Replace the fuse.

2. Battery

• Check the battery condition. Refer to "CHECKING AND CHARGING THE BATTERY" in chapter 3.

**Open-circuit voltage:**

**12.8 V or more at 20 °C (68 °F)**

CORRECT  
↓

INCORRECT

- Clean the battery terminals.
- Recharge or replace the battery

3. Main switch

Refer to "CHECKING THE SWITCH".

CORRECT  
↓

INCORRECT

Replace the main switch.

# ELECTRICAL COMPONENTS

## 4. Radiator fan motor

- Disconnect the radiator fan motor coupler.
- Connect the battery (12 V) as shown.

**Battery (+) lead → Brown terminal ①**

**Battery (-) lead → Blue/Red terminal ②**

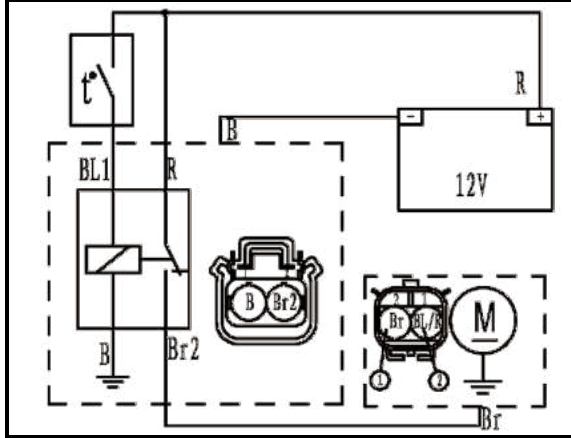

- Check the operation of the radiator fan motor.

DOES NOT TURN



Replace the radiator fan motor.

## 5. Thermo switch 3

- Remove the thermo switch 3 from the radiator.
- Connect the pocket tester ( $\Omega \times 1$ ) to the thermo switch 3 ①.
- Immerse the thermo switch 3 in coolant ②.
- Check the thermo switch 3 for continuity. While heating the coolant use a thermometer ③ to record the temperatures.

A The thermo switch 3 circuit is closed.

B The thermo switch 3 circuit is open.

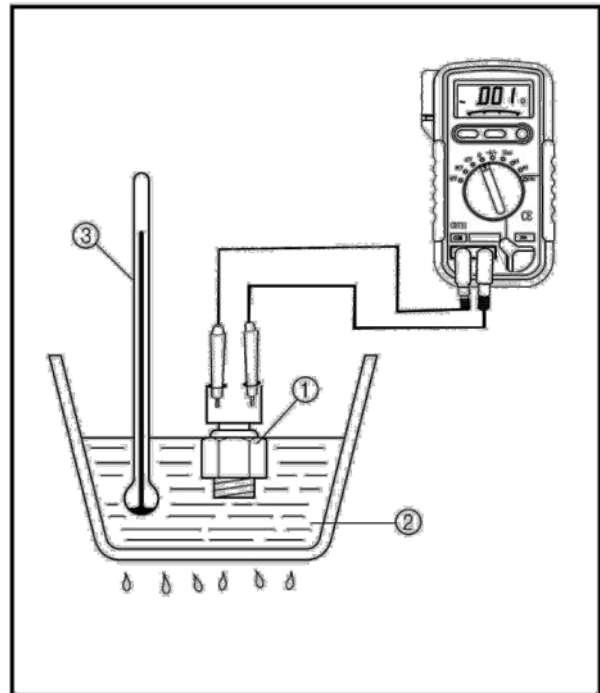

Test step	Coolant temperature	Continuity
1	Less than $75 \pm 3$ °C ( $167 \pm 5.4$ °F)	No
2	More than $75 \pm 3$ °C ( $167 \pm 5.4$ °F)	Yes
3	More than 68 °C (154.4 °F)	Yes
4	Less than 68 °C (154.4 °F)	No

Test steps 1 & 2: Heating phase

Test steps 3 & 4: Cooling phase

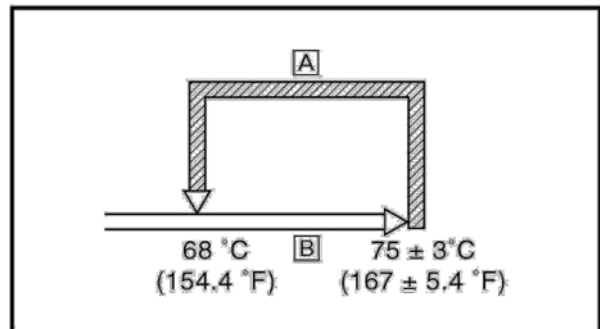

# ELECTRICAL COMPONENTS

---

**WARNING:**

Handle the thermo switch 3 with special care.  
Never subject it to a strong shock or allow it to be dropped. Should it be dropped, it must be replaced.

Thermo switch 3  
28 Nm (2.8 m · kg, 20 ft · lb)

GOOD CONDITION

6. Wiring connection

• Check the connections of the entire starting system. Refer to "CIRCUIT DIAGRAM"

CORRECT

This circuit is not faulty.

BAD CONDITION

Replace the thermo switch 3

POOR CONNECTION

Properly connect the cooling system.

**2WD/4WD SELECTING SYSTEM  
CIRCUIT DIAGRAM (see 442 page)**

# ELECTRICAL COMPONENTS

---

## TROUBLESHOOTING

### 1. Check if the 2/4WD switch is working.

a. Turn on the switch, put the gear to position N; keep front and rear wheel off the ground , and then roll the front wheel to see if the rear wheel is moving together with it or if it is rotatable.

b. After the actions above being done, and the wheels are rotatable, please check the electricity with multimeter, if has no electricity, please check the fuse.

### 2. Check if the rear differential is working.

a. Check the sound. When the switch is turned on, the magneto valve will make s sound 'TA' to show that it is working and the rear wheel won't be able to rotatable at the same direction.

b. If no sound is made, check if the controller of magnetic valve has a output of 12V electricity, and check if the magnetic valve has a input of 12V electricity,if it has the input, it means the valve doesn't work, please change for a new one ; if not , please check if the input end of controller has a input, if it has, change for a new controller, if not , check the fuse.

# ELECTRICAL COMPONENTS

## Check the working state of oxygen sensor:

### (1).Diagnostic instrument

- Connect the diagnostic instrument to check whether the EFI system reports the failure of oxygen sensor.

OXYGEN SENSOR  
FAILURE

After clearing the fault, start to test whether the fault occurs again.

OXYGEN SENSOR  
FAILURE

### (2).Oxygen sensor connector

Check Whether the Oxygen sensor connector is well connected.

WELL CONNECTED

### (3).continuity

- Connect the pocket tester, Check the EFI line for continuity as follows.

①

**Tester (+) lead → A**

**Tester (-) lead → J2-10**

②

**Tester (+) lead → B**

**Tester (-) lead → J2-17**

③

**Tester (+) lead → C**

**Tester (-) lead → J2-7**

④

**Tester (+) lead → D**

**Tester (-) lead → J2-15**

The above four test results should continuity

CORRECT

The oxygen sensor is damaged. Replace the oxygen sensor.

NO OXYGEN SENSOR FAULT



Oxygen sensor works normally.

NO OXYGEN SENSOR FAULT



Oxygen sensor works normally.

NOT WELL CONNECTED



Make sure the Instrument connector is well connected, repeat operation (1).

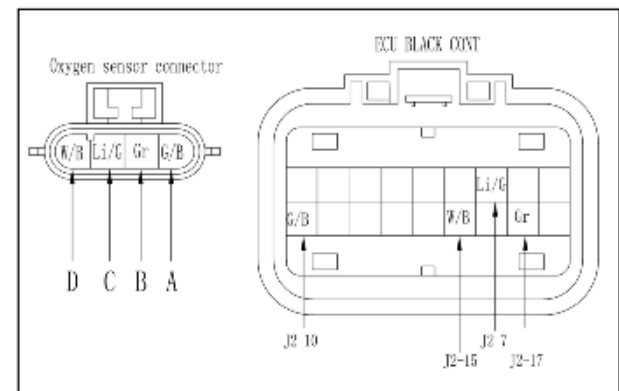

INCORRECT



The wiring circuit from the ECU to the oxygen sensor connector is faulty, repair it.

# ENGINE MANAGEMENT SYSTEM

## INTRODUCTION

### EMS (Engine Management System)

EMS is a self contained set of components including a custom built computer and sensors and actuators which control the operation of an engine by monitoring the engine speed, load and temperature and providing the ignition spark at the right time for the prevailing conditions and metering the fuel to the engine in the exact quantity required.

### Typical Components Of EMS(Bucket seat)

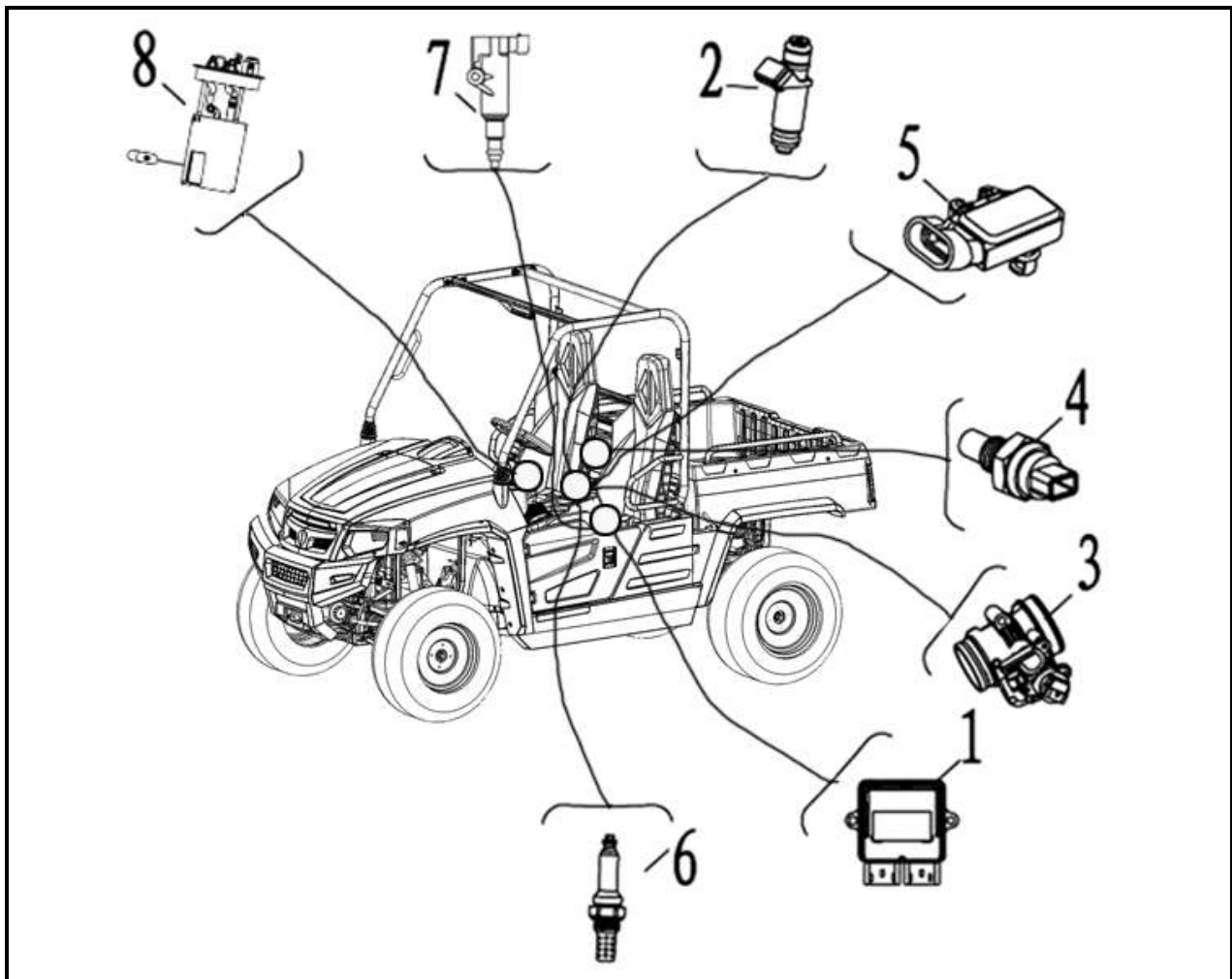

1. Electronic Control Unit
2. Multec 3.5 Injectors
3. Throttle Body Assembly(with stepper motor)
4. Engine Coolant Temperature Sensor
5. Intake Air Pressure and Temperature Sensor
6. Oxygen Sensor
7. Ignition Coil
8. Fuel Pump Module



## ENGINE MANAGEMENT SYSTEM

### Typical Components Of EMS(Bench seat)

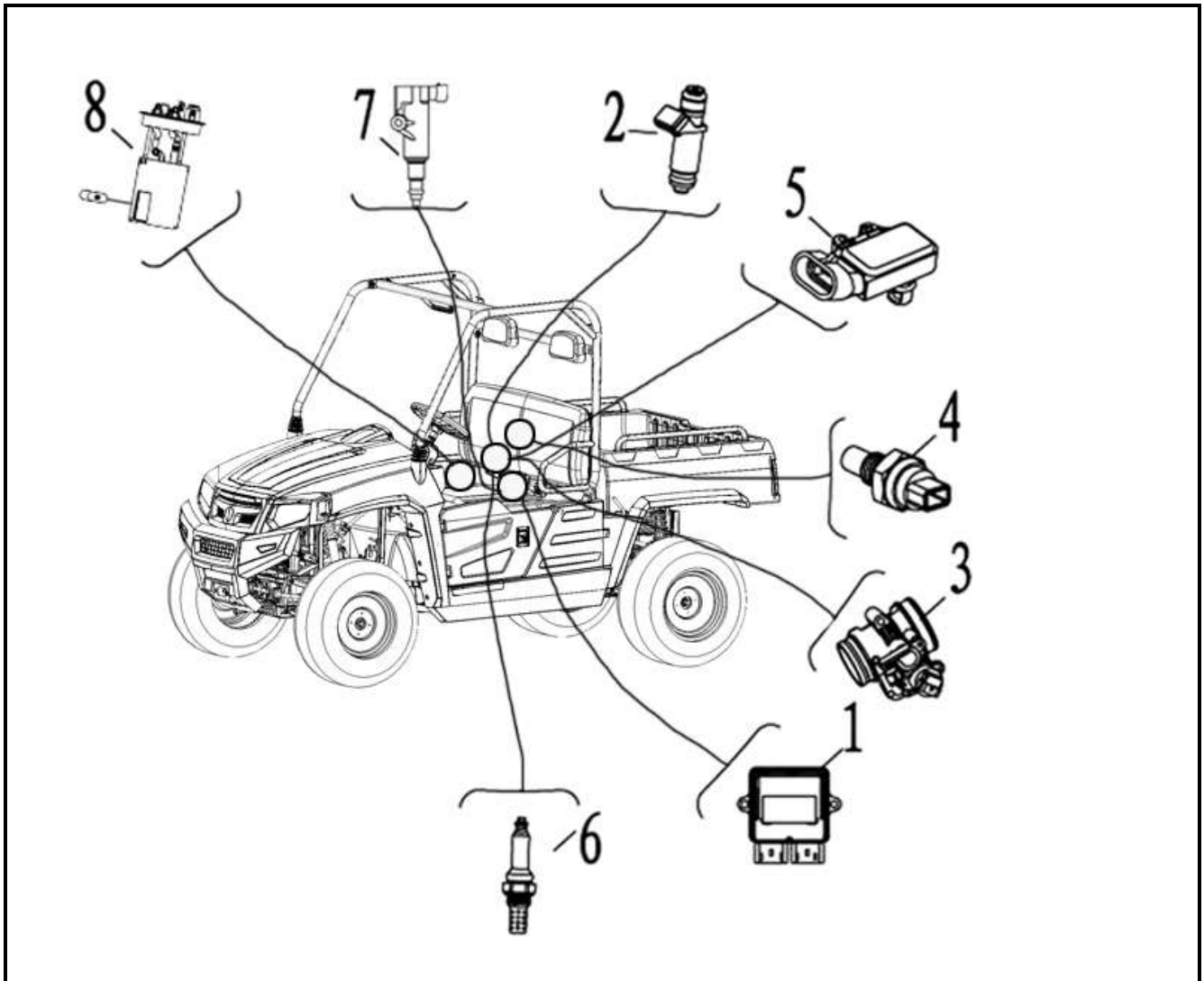

- |   |
|---|
| 1. Electronic Control Unit                    |
| 2. Multec 3.5 Injectors                       |
| 3. Throttle Body Assembly(with stepper motor) |
| 4. Engine Coolant Temperature Sensor          |
| 5. Intake Air Pressure and Temperature Sensor |
| 6. Oxygen Sensor                              |
| 7. Ignition Coil                              |
| 8. Fuel Pump Module                           |

# ENGINE MANAGEMENT SYSTEM

## Layout of EMS Components

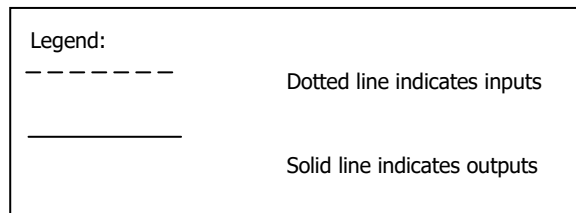
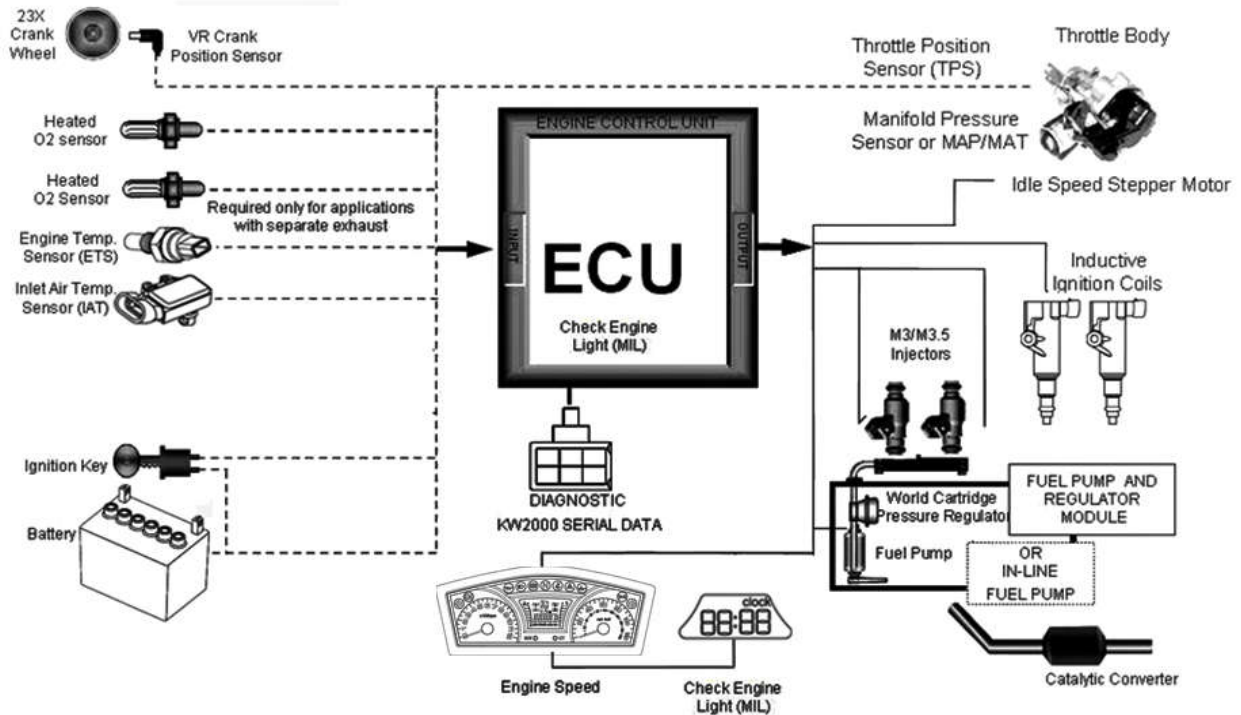

## COMPONENTS OF EMS

### Electronic Control Unit

#### 1. Description & Working Principle

The ECU continuously monitors the operating conditions of the engine through the system sensors. It also provides the necessary computation, adaptability, and output control in order to minimize the tailpipe emissions and fuel consumption, while optimizing vehicle drivability for all operating conditions. The ECU also provides diagnosis when system malfunctions occur.

#### 2. Handling – DOs & DONTs

## ENGINE MANAGEMENT SYSTEM

ECU Handling	
ACTION	REASON
<b>DO NOT:</b> Place the ECU close to the exhaust pipe or Engine when removed	High temperature might reduce the life of the ECU and also can damage the ECU
<b>DO NOT:</b> Place the ECU close to or pour water, oil or any other liquids.	ECU is susceptible to water and liquids
<b>DO NOT:</b> Allow mud or other debris to accumulate on the surface of the ECU	Having mud or debris accumulated on the ECU casing reduces its heat dissipation efficiency.
<b>DO NOT:</b> Apply any voltage relative to any point to the ECU	Drastically affects the performance of the ECU and may lead to ECU damage
<b>DO NOT:</b> Clean ECU with any solvent or any corrosive liquid	Can damage the housing of the ECU
<b>DO:</b> Take extreme care that water droplets or excess moisture should not fall on ECU connectors	ECU connectors can get short and may lead to ECU damage
<b>DO:</b> Clean the ECU with a moist cloth and keep it dry	Prevents ECU damage

### 3. Installation requirements

The ECU shall be mounted using M5 machined screws with a torque of 3.9Nm  $\pm$  10%. The mounting surface should also be flat to avoid subjecting the base plate to unnecessary force and warping the PCB.

### 4. Maintenance service and Repair

ECU is a non-serviceable part. Once there are problems, it's important to first determine if the problem is caused by software/calibration. If it is caused by software/calibration, please refer to software/calibration reflashing procedure. In the event of ECU hardware failure or malfunction (during warranty period only) the ECU should be sent back to the vehicle manufacturer giving complete details of the ECU Part No, Serial number, Vehicle Model & Make, manufacturing Date, Total kms run on the vehicle, Location of use, Vehicle No, Date of return.

## Multec 3.5 Injectors

### 1. Description and Working Principle

The Multec 3.5 Fuel Injector is an electromechanical device. A magnetic field is generated as voltage is applied to the solenoid coil. The resulting magnetic force lifts the core assembly, overcoming manifold vacuum, spring force, and fuel pressure, allowing fuel to pass through the ball and seat interface to the director. As the fuel passes through the director, an atomized spray is developed. The injector closes when the voltage is removed, cutting off the fuel flow.

## ENGINE MANAGEMENT SYSTEM

### 2. Handling - DOs & DONTs

<b>3.5 FUEL INJECTOR HANDLING</b>	
<b>ACTION</b>	<b>REASON</b>
<b>DO NOT:</b> Re-use injector seal rings if at all possible. If no other choice exists, take extra care in inspecting the seal rings for damage.	Leakage.
<b>DO NOT:</b> Dip injector tips into lubricants.	Can plug injector spray orifices.
<b>DO NOT:</b> Cycle injector repeatedly without fuel pressure.	Damage to internal mechanical components.
<b>DO NOT:</b> Pulse (actuate) a suspected high leak rate injector (leak >50 sccm air).	Can dislodge internal contamination if present and preclude root cause analysis.
<b>DO NOT:</b> Allow water to enter fuel system from air lines, etc. during leak checks.	Can damage injectors.
<b>DO NOT:</b> Contact or apply load to the injector tip for installation.	Apply load to 45 deg angle on nylon over mold see
<b>DO NOT:</b> Pound injectors into manifold during assembly to engine.	Can damage injectors or seal rings.
<b>DO NOT:</b> Apply excessive side loads to electrical connectors.	May cause loss of electrical continuity.
<b>DO NOT:</b> Use any dropped unit.	Internal damage may have occurred.
<b>DONOT:</b> Store injectors, rails, or subassemblies including engines on which the injectors have been installed in an unprotected environment.	External contamination can damage the injector electrically and/or mechanically.
<b>DO NOT:</b> Use the injector as a handle.	Do not use the injector to lift assemblies
<b>DO NOT:</b> Rack, stage, or handle parts in a manner that allows contact between parts.	Damage will occur.
<b>DO NOT:</b> Remove packing in a way that allows contact between parts.	Damage could occur due ton contact between parts.
<b>DO NOT:</b> Tap on fuel injectors to correct any malfunction.	Can damage injector.
<b>DO NOT:</b> Replace the injector with other part number not recommended for this application	Will severely affect the performance of the injector
<b>DO:</b> Take extra care when installing new fuel seal ring over injector inlet flange.	Prevent tearing seal ring during installation.

## ENGINE MANAGEMENT SYSTEM

<b>DO:</b> Use proper lubricants on seal ring surfaces to install injector in engine. Minimize time between applying lubricant and inserting injector / rail.	Avoid damage to seal ring during installation. Avoid contamination at seal.
<b>DO:</b> Pulse (actuate) stuck closed or tip-leak suspected injector (Actuate consists of one pulse <5 sec duration at 9 to 15V).	To verify the injector failure
<b>DO:</b> Pulse (actuate) injectors prior to a dry fuel system leak test at engine/vehicle assembly to reseal injector valves.	Injector valves may not reseal without fuel after shipping and handling resulting in false leakage.
<b>DO:</b> Avoid any liquid contamination in the injector area.	Coil could short circuit.
<b>DO:</b> Use care during connection of harness to injector.	Avoid terminal damage.
<b>DO:</b> Use recommended terminal lubricant on mating connector.	Minimize potential for terminal fretting corrosion.
<b>DO:</b> Return any dropped, damaged, or suspect material with a tag that describes the problem.	Ensure fast and correct diagnosis of root cause.

### 3. Installation guidelines

Follow these guidelines to prevent damage to the injector and its electrical interface during the replacement or re-installation process.

- Lubrication: Apply a light coating of lubricant to the lower injector seal ring. ISO 10 light mineral oil or equivalent is recommended.
- The preferred technique is to apply the lubricant to the sockets the injectors are being installed into, rather than directly to the seal ring itself. This will help minimize the possibility of injector contamination.
- Avoid applying lubricant over the director plate holes – this may restrict injector flow. Do not dip the injector tip in lubricant.
- Multec 3.5 injectors come from the factory with the seal rings attached. The re-use of seal rings is not preferred when replacing an injector. If an injector is to be re-used, and no new seal rings are available, take care to inspect each seal ring for signs of damage. Even minor defects in the seal ring can lead to leakage. Take extra care in installing seal ring over flange of injector inlet.
- Carefully installing the harness connector will prevent terminal damage. Listen for a positive audible click from the connector retention device — this ensures that it is fully engaged. Shut off ignition.
- Disconnect negative battery cable to avoid possible fuel discharge if an accidental attempt is made to start the engine.
- Disconnect the electrical connector from the injector wiring harness.
- Relieve fuel pressure
- Remove the retaining clip from the fuel injector.

## ENGINE MANAGEMENT SYSTEM

---

- Remove the fuel line connection from the injector
- Carefully clean debris from the interface surfaces. Do not damage seal mating surfaces.
- Remove the injector from the manifold
- Apply a light coating of a lubricant to both the upper and lower injector seal ring of the replacement injector.
- Install the new injector into the manifold. Check that the injector is installed in the original orientation to maintain proper spray targeting, and that the retaining clip is properly seated on the injector and the fuel line
- Install the retaining clip after connecting the fuel line
- Tighten the injector mounting to the desired torque as mentioned in the manufacturer manual
- Tighten the fuel line
- Re-install the injector electrical connector
- Check for fuel leaks with the key “on” and the engine “off”
- Start engine and verify proper operation.
- or spray pattern, do not rotate the injector in the fuel rail assembly to install the injector electrical connector. This may dislodge the retaining clip, and result in improper spray orientation

### 4. Replacement Techniques

#### **WARNING:**

***The injector and all associated hardware may be extremely hot.***

- Shut off ignition.
- Disconnect negative battery cable to avoid possible fuel discharge if an accidental attempt is made to start the engine.
- Disconnect the electrical connector from the injector wiring harness.
- Relieve fuel pressure
- Remove the retaining clip from the fuel injector.
- Remove the fuel line connection from the injector
- Carefully clean debris from the interface surfaces. Do not damage seal mating surfaces.
- Remove the injector from the manifold
- Apply a light coating of a lubricant to both the upper and lower injector seal ring of the replacement injector.
- Install the new injector into the manifold. Check that the injector is installed in the original orientation to maintain proper spray targeting, and that the retaining clip is properly seated on the injector and the fuel line
- Install the retaining clip after connecting the fuel line
- Tighten the injector mounting to the desired torque as mentioned in the manufacturer manual
- Tighten the fuel line
- Re-install the injector electrical connector
- Check for fuel leaks with the key “on” and the engine “off”
- Start engine and verify proper operation.

## **ENGINE MANAGEMENT SYSTEM**

---

### **5. Plugging**

Fuel deposits cause plugging resulting in flow shifts over the life of the injector. Fuel varnish or gumming, a type of injector deposit, is created when certain types of fuel are heated by high injector tip temperatures at soak (no fuel flow). Deposit build up in the director holes causes the flow shifts

- Plugging can cause flow restrictions, frictional changes and the collection of other particles attracted by the tacky surface. The flow restrictions can degrade emissions and drivability.
- Other fuel and environmental conditions may cause crystal or corrosion growth in the injector and cause a flow shift.
- Oxidation stability of the gasoline affects the potential for deposit formation and must be controlled by the fuel supplier.
- Increased levels of detergent additives reduce the rate of injector plugging.
- In case of plugging of injector follow the injector cleaning procedure mentioned in the section below

### **6. Cleaning Procedure**

- Electrically disable the fuel pump by removing the fuel pump connection.
- Relieve the fuel pressure in the system and disconnect the fuel connection at the injector. Plug the fuel feed line.
- Injector cleaner with the specific ratio of the cleaner and gasoline to be mixed in the Injector cleaning tank.
- Connect the injector-cleaning tank to injector in the vehicle.
- Pressurize the injector-cleaning tank to system pressure.
- Start and idle the engine for 15- 20 minutes.
- Disconnect the injector-cleaning tank from the system and install the fuel pump connections. Connect the fuel feed line to injector.
- Start and idle the vehicle for an additional 2 minutes to ensure the residual injector cleaner is flushed from system.

## **Throttle Body Assembly(with stepper motor)**

### **1. Description and Working Principle**

The Throttle Body Assembly is an interactive system comprised of the following subsystems: the main casting body, bearing system, shaft and valve system, return spring system, cable interface system, throttle position sensing system, and the bypass air control system. The subsystems interact and support each other to provide all the functional requirements, which are mentioned below -

- Control intake air flow
- Control idle air flow
- Sense throttle position - Provide position feedback to Engine Controller
- Provide reactionary force to the throttle

## ENGINE MANAGEMENT SYSTEM

### 2. Handling – DOs and DONTs

<b>THROTTLE BODY ASSEMBLY HANDLING</b>	
<b>ACTION</b>	<b>REASON</b>
<b>DO:</b> Use care during assembly of harness to throttle body.	Avoid terminal damage.
<b>DO:</b> Avoid any liquid contamination in the throttle body area.	Ensure proper operation.
<b>DO:</b> Unload and install units one at a time from packing trays.	Damage may be done to critical components.
<b>DO:</b> Return any dropped, damaged, or suspect material with a tag that describes the problem. (Only warranty cases)	Ensure fast and correct diagnosis of root
<b>DO:</b> Remove and discard protective caps just before assembling mating components.	Protects system from contamination, which can prevent proper operation.
<b>DO:</b> clean the by pass passage after removing bottom cover	To ensure good idle stability
<b>DO NOT:</b> Use any dropped or impacted unit.	Internal damage may have occurred or emissions settings may have been upset.
<b>DO NOT:</b> Store units without protective caps in place.	Contamination may impair correct operation.
<b>DO NOT:</b> Ship or store near saltwater without protection.	Corrosion buildup may impact proper operation.
<b>DO NOT:</b> Exposed to environmental conditions (Moisture) prior to complete vehicle installation.	Corrosion buildup may impact proper operation.
<b>DO NOT:</b> Apply any voltage other than system voltage for testing.	Damage could occur.
<b>DO NOT:</b> Apply excessive band clamp loading	Damage could occur.
<b>DO NOT:</b> Remove packing in a way that allows contact between parts.	Minimum air leakage could be affected and/or other damage could occur.
<b>DO NOT:</b> Release the throttle cam abruptly from any position without the throttle linkage attached.	Damage could occur.
<b>DO NOT:</b> Let the by pass holes be blocked by dirt or foreign particles.	This could effect idle stability
<b>DO NOT:</b> Rake, stage, or handle parts in a manner that allows contact between parts.	Damage will occur.

### 3. Throttle Body Removal

- Disconnect negative terminal of the battery
- Disconnect electric lead wire of throttle position sensor coupler, stepper motor coupler and MAP/MAT sensor coupler ( if this sensor is mounted on the throttle body)
- Disconnect accelerator cable from throttle body



## **ENGINE MANAGEMENT SYSTEM**

---

- Remove air cleaner outlet hose and throttle body outlet hose

### **4. Cleaning Procedure**

If there is cover on the bottom, it may be removed and cleaned using carburetor cleaner (3M make recommended). Once the throttle body cover is removed, spray the throttle-body cleaner inside the shipping air passage, and use the brushes to gently dislodge the dirt, gum and varnish that are present. Do not let the by pass holes be blocked by dirt or foreign particles.

### **5. Throttle Body Installation**

- Reverse the procedure for installation noting the following:
- Adjust accelerator cable play
- Check to ensure that all removed parts are back in place. Reinstall any necessary part which have not been reinstalled

### **6. Precautions**

- Do not submerge TPS in any cleaning fluid.
- Always open the throttle valve using the throttle cable or lever.
- Do not hold the valve at opening position by inserting tools or any sticks into the bore. The valve may be warped and the bore may be scratched. This type of damage may keep the throttle from opening easily or fully closing.

## **Engine Coolant Temperature Sensor**

### **1. Description and Working Principle**

This sensor is used in water cooled engines. It provides a resistance that varies as a function of temperature within prescribed tolerance limits. The sensor has a negative temperature coefficient of resistance. This is a non-serviceable part.

### **2. Installation Requirements**

- **Dynamic Torque Requirement:** The sensor shall be hand into the application and then driven by a driver with a maximum no load speed of 400 rpm or installed to the desired torque by a hand torque wrench (5/8" hex). The recommended installation torque is:  
Minimum: 20 N·m  
Maximum: 25 N·m
- **Static Torque Requirement:** The torque required to remove the sensor from the mating hole shall be within 200% of the installation torque mentioned above.

### **3. Sample Cleaning**

- When necessary the samples may be cleaned in isopropyl alcohol for one minute with mating connectors in place and then air-dried

## **Intake Air Pressure and Temperature Sensor**

### **1. Description and Working Principle**

# ENGINE MANAGEMENT SYSTEM

This sensor has two functions. The first is the intake manifold air temperature, it provides a resistance that varies as a function of temperature within prescribed tolerance limits. The second is the intake manifold air pressure; it provides a voltage varies as the intake air pressure.

## 2. Sample Cleaning

- When necessary the samples may be cleaned in isopropyl alcohol or gasoline for one minute with mating connectors in place and then air-dried

## Oxygen Sensor

### 1. Description and Working Principle

This sensor is a device for monitoring the residual oxygen in the exhaust of an internal combustion engine. It consists of the wide range sensor and stoichiometric sensor. Usually we use stoichiometric sensor on the small engine. It is the feedback element for engine closed loop control.

### 2. Installation Requirements

- Mounting Angle with Level:  $\geq 10$  degree
- Tightening Torque Requirement: 40-60 Nm

## Ignition Coil

### 1. Description and Working Principle

This coil provides energy to the spark plug in the combustion chamber. The coil itself doesn't have a driver. The high voltage tower of the coil is connected to the spark plug using a high voltage cable assembly. This is a non-serviceable component.

### 2. Installation requirements

- The vehicle frame provides the mounting surface and mounting holes.
- Mount coil close to the spark plug and keep the plug wire length very short (less than 6").
- Mount coil away from any pick coil device. Especially, a VR type Crank / Cam sensor. Keep a Min distance of 150 mm (around 6") between coil and any VR sensor device.
- Never route the coil C- wire with the same bundle as the Crank sensor wires. There is around 200 V peak potential between C- wire and engine ground. This voltage potential could cause a noise on sensor cables.

### 3. DOs and DONTs

Ignition Coil Handling	
Action	Reason
<b>DO NOT:</b> Install the low voltage connectors with the power applied	This might cause an unwanted secondary firing, possibly leading to personal injury

## ENGINE MANAGEMENT SYSTEM

<p><b>DO NOT:</b> Use a screw driver to assist in removing secondary boots from the secondary tower. Use tools designed for secondary removal.</p>	<p>It is possible to damage a secondary lead in such a manner that creates an electrical path to outside the system permitting improper system operation misfire, or even possible personal injury if arcing occurs.</p>
<p><b>DO NOT:</b> Use parts that have been dropped or display physical damage</p>	<p>Damaged components can lead to premature failure.</p>
<p><b>DO NOT:</b> Scratch or apply any non approved material to the surface of the high voltage tower which mates with the high voltage secondary leads.</p>	<p>This can jeopardize the seal integrity of the mating surfaces which in turn can create a secondary high voltage leak path.</p>
<p><b>DO NOT:</b> Strike any part of the ignition system with a tool or other object.</p>	<p>This can lead to physical damage which can cause a system malfunction or failure.</p>
<p><b>DO NOT:</b> Permit paint or other sprayed materials to be sprayed onto the electrical connectors.</p>	<p>Insulating type sprays can create a high resistance or open connection. And, a conductive type spray can create an electrical short condition.</p>
<p><b>DO NOT:</b> Support the ignition system by the wiring harness or plug wire.</p>	<p>These leads are not designed to support the weight of the ignition system. It can create a poor electrical connection Or become disconnected allowing the system to fall and be subjected to physical damage</p>
<p><b>DO NOT:</b> Pierce or probe the secondary leads.</p>	<p>This creates an electrical path to outside the system permitting improper system operation, misfire, or even possible personal injury if arcing occurs.</p>
<p><b>DO NOT:</b> Operate without the spark plug attached.</p>	<p>If a technician or mechanic comes in contact with the high voltage generated during operation, personal injury may occur. Or, if the engine is operated under this condition, unburned fuel may fill the converter area creating a potential hazard</p>
<p><b>DO NOT:</b> Share ignition component wiring with other components, Dedicated wiring is required.</p>	<p>This prevents electrical cross talking between components which can lead to component malfunction.</p>
<p><b>DO NOT:</b> Apply voltage to the ignition system other than vehicle system voltage for testing purposes.</p>	<p>This can cause reduced performance or an electrical malfunction of the ignition system.</p>
<p><b>DO NOT:</b> Use high impact tools to apply the spark plug boot to the ignition secondary towers. Installation of the high voltage secondary leads by hand is preferred.</p>	<p>Damage to the coil tower, secondary boot, or mating connection surfaces might occur.</p>

## ENGINE MANAGEMENT SYSTEM

<b>DO:</b> Install the secondary leads before connecting the primary leads.	In the event the low voltage connection has been made and the power applied, unwanted secondary output might occur possibly resulting
	in injury, damage the ignition component, and test equipment
<b>DO:</b> Take care when working around the ignition system.	The high voltage produced by the coil secondary circuit can cause personal injury and/or damage test equipment
<b>DO:</b> Proper handling and shipping methods need to be in place to reduce the risk of damage due to impact, moisture, or contamination	Damaged components can lead to premature failure.
<b>DO:</b> Avoid unnecessary disconnecting and connecting of the electrical components.	The electrical connections are not designed for repeated connection and disconnection.
<b>DO:</b> Insure the low voltage connectors are entirely seated and the locking mechanism is engaged.	This prevents intermittent electrical connections leading to an improper ignition system operation.
<b>DO:</b> Use approved connector breakouts when testing the ignition system.	Connector and/or component damage may occur.
<b>DO:</b> Insure the appropriate seals are included in the connector system.	Liquid intrusion into the terminal connection area might occur causing an electrical intermittent or short condition. In the event of severe terminal corrosion, an open condition might occur.
<b>DO:</b> Operate with gasoline based internal combustion engines.	Other fuels or combustion designs may require additional design considerations.
<b>DO:</b> The power feed line should be fused.	This could protect the system in the event of an electrical short
<b>DO:</b> The module heat sink and back plate must not be used as a connection point when jump starting the engine	The high level of voltage and current which the module could be subjected to, could cause module performance degradation or failure.
<b>DO:</b> Connection of the module back plate to vehicle ground is desirable whenever possible	This greatly reduce potential ground loops and acts as a heat transfer source from the module.
<b>DO:</b> The ignition system ground wire should be kept as short as possible. And, when permissible, should be grounded at the same engine block position as the engine controller	This would greatly reduce the possible of unwanted electrical ground loops.
<b>DO:</b> The electrical wiring to the ignition system should be routed so that the conductors are protected from excessive heat, damage, and wear.	Helps prevent electrical intermittent, open or shorted operating conditions.
<b>DO:</b> Ignition secondary leads should not be routed with the ignition primary harness or any other electrical harness.	Voltage spikes can be transmitted from the secondary cables into other leads which are in close. This could create a component performance degradation or failure condition

## ENGINE MANAGEMENT SYSTEM

<p><b>DO:</b> Spark plug wires(secondary leads) &amp; primary wiring:</p> <ul style="list-style-type: none"> <li>- must not contact sharp surface</li> <li>- must not be under tension between fixed points</li> <li>- must be clear of moving parts (belts, fan, etc...)</li> <li>- must be protected from or kept at least 125 mm away from radiant heat source exceeding 400 F.</li> <li>- must be protected from environmental damage (dirt, splash, oils, fluids, etc....)</li> <li>- must be retained, secured or insulated to prevent pinching, mis-routing, rattles, and squeaks</li> </ul>	<p>- Spark plug wires carry very high voltage (30,000 volt). If the secondary lead loses its dielectric characteristics thru being nicked, cut , chaffed, then an arc thru to a near by ground could take place. This kind of condition could lead to misfire, no start, or premature failure of ignition system.</p>
<p><b>DO:</b> Not all fasteners are designed for repeat use. Beware of fastener specifications. All harnesses should be supported within 6" of a mating connection.</p>	<p>Adequate retention force might not be achieved if the fastener is not designed to be reused. Mating connections are not designed to support the weight of the harness assembly.</p>
<p><b>DO:</b> For removing spark plugs follow the following steps:</p> <ol style="list-style-type: none"> <li>1- Grasp the spark plug boot and gently</li> <li>2- rotate 90°; and then pull the spark plug boot and cable away from the spark plug</li> <li>3- Before removing spark plug, brush or air blast dirt away from the well areas</li> <li>4- Use correct size deep socket wrench to loosen each spark plug one or two turns</li> </ol>	<p>To remove spark plugs from Aluminum heads, allow the engine to cool. The heat of the engine, in combination with a spark plug that is still hot, may cause the spark plug threads to strip the cylinder head upon removal</p> <p>Use goggles to protect eyes from dirt when applying compressed air to spark plug wells</p>
<p><b>DO:</b> Cleaning a spark plug could be done as follow:</p> <ol style="list-style-type: none"> <li>1- wipe all spark plug surfaces clean....remove oil, water, dirt and moist residues.</li> <li>2- If the firing end of spark plug has oily or wet deposit, brush the spark plug in an approved, non-flammable and non-toxic solvent. Then dry the spark plug thoroughly with compressed air</li> <li>3- Use a propane torch to dry wet-fuel fouled plugs. Allow the torch flame to enter up the center electrode insulator. Allow plug to cool down</li> <li>4- If the spark plug threads have carbon &amp; scale deposits, clean with wire brush, taking care not to injure the electrode or the insulator tip</li> </ol>	<p>-Cleaning a spark plug will reduce the voltage required for an electrical arc(spark) across the electrodes</p> <p>-Cleaning &amp; re-gapping will not restore a used spark plug to a new condition. It may be more economical and efficient to replace used spark plugs with new plugs instead of cleaning.</p> <p>-Sooted plugs should be replaced</p> <p>-Do not cool by using water or any liquid</p> <p>-Clean threads permit easier installation and proper seating which will maximize transfer heat away from the plug</p>

## ENGINE MANAGEMENT SYSTEM

<p><b>DO:</b> Regap spark plugs to the exact measurement specified by the engine</p>	<p>-Too wide a gap could cause the plug to misfire(higher required ignition voltage).</p>
<p>manufacturer to keep the best fuel economy and proper engine performance</p> <ul style="list-style-type: none"> <li>- Use round wire-type gauge for an accurate measure of gap on all used spark plugs</li> <li>- when gapping a spark plug only the side electrode is moved. The center electrode must not be moved</li> </ul>	<p>-Too narrow of a gap could affect idle stability</p> <p>-A flat gauge can't accurately measure the spark plug on used plugs</p>
<p><b>DO:</b> When replacing spark plugs with new ones, always use equivalent plugs with same heat range, thread, size, etc....</p>	<p>-Higher heat range plug(hotter plug) could lead to pre-ignition &amp; possible piston damage</p> <p>-Lower heat range (colder plug) could lead to cold fouling &amp; emission problem</p>
<p><b>DO:</b> For installing spark plugs follow the following steps:</p> <ol style="list-style-type: none"> <li>1- make sure the cylinder head threads and spark plug threads are clean. Make sure the spark plug thread is free of dings and burrs. If necessary, use a thread chaser and seat cleaning tool.</li> <li>2- Make sure the spark plug gasket seat is clean, then thread the gasket to fit flush against the gasket seat. Tapered seat plugs do not require gaskets</li> <li>3- Screw the spark plugs finger-tight into the cylinder head. Then, use a torque wrench to tighten spark plugs following manufacturer's recommendation).</li> </ol> <p>Torque is different for various plug type &amp; cylinder head material</p>	<p>-If the thread is damage, it prevents a good heat transform from the shell to the cylinder head</p> <p>-Do not use any type of anti-seize compound on spark plug threads. Doing this will decrease the amount of friction between the threads. The result of the lowered friction is that when the spark plug is torqued to the proper specification, the spark plug is turned too far into the cylinder head. This increases the likelihood of pulling or stripping the threads in the cylinder head</p> <p>-Over-tightening of a spark plug can cause stretching of the spark plug shell and could allow blowby to pass thru the gasket seal between the shell and insulator. Over-tightening also results in extremely difficult removal</p>

### Fuel Pump Module

#### 1. Description and Working Principle

Fuel Pump Module supplies fuel to engine at system pressure. Fuel Pump Module is mounted to fuel tank at bottom and supplies fuel to engine through hoses.

Fuel Pump module consists of Fuel Pump to generate the fuel flow and pressure regulator to regulate the fuel pressure.

Fuel Pump

When power is supplied to fuel pump, motor in pump assembly rotates the impeller. Impeller in turn draws the fuel from strainer and pumps the flow to generate the system pressure.

Pressure Regulator

## **ENGINE MANAGEMENT SYSTEM**

Pressure Regulator is a diaphragm type mechanical device. Fuel flow from filter enters in the inlet of pressure regulator. Pressure regulator regulates the fuel pressure at a set pressure by releasing the excessive fuel flow to fuel tank.

### **2. Service Procedure:**

Precautions:

Before attempting any service on fuel system, following cautions should be always followed for personal safety and to avoid system damages.

- Disconnect negative cable at battery.
- DO NOT smoke, and place 'No SMOKING' sign near work area
- Make sure to have fire extinguisher handy.
- Make sure to perform work in well ventilated area and away from any open fire/flames.
- Wear Safety glasses
- To relieve fuel vapor pressure in fuel tank, remove fuel filler cap fuel filler neck and then reinstall it.
- As fuel lines are at high pressures when the engine is stopped, loosening or disconnecting fuel line will cause dangerous spout of fuel. Before loosening/ disconnecting fuel lines, please follow the "Fuel Pressure Relief Procedure" described in this section.
- Small amount of fuel may drip after the fuel lines are disconnected. In order to reduce the risk of personal injury, cover the pipe/ hose ends with suitable blind with no rust or contamination.
- After servicing, make sure that the fuel hoses and clamps are connected according to the hose fitment instructions given in vehicle instruction manual.
- After servicing, please follow the 'Fuel Leakage Check Procedure' described in this section.
- After servicing make sure to fill at least 3 liters gasoline before pump is primed (ignition key should be turned on only after ensuring there is minimum 3 liters of fuel in the fuel tank)

### **Fuel Module Diagnosis:**

Step	Action	Yes	No
1	Switch on Ignition key. Fuel Pump primes for 3 seconds when the ignition key is ON. Check for fuel pump running noise for 3 seconds after ignition key is ON.	If fuel pump running noise can be heard, go to step 4.	If fuel pump running noise can not be heard, go to step 2.
2	Disconnect fuel module coupler. Check voltage at harness coupler.  Is the voltage within 10-14V	Go to step 3	Check the electrical circuit from Ignition to fuel module.

## ENGINE MANAGEMENT SYSTEM

3	<p>Connect 12V DC power supply (battery) to fuel module. Make sure that enough fuel available in fuel tank to avoid fuel pump running dry. Is the fuel pump running</p>	<ol style="list-style-type: none"> <li>1. Check electrical circuit from fuel module to ECU</li> <li>2. Check ECU</li> </ol>	<ol style="list-style-type: none"> <li>1. Check Fuel Pump Harness integrity</li> <li>2. Check Fuel Pump</li> </ol>
4	<p>Check fuel system pressure at Injector inlet (with a T-joint) while engine is running in idle condition.  Is the pressure between 220 ~ 270kPa?</p>	<p>Fuel Module Operation Normal</p>	<p>Go to Step 5</p>
5	<p>Is the Pressure below 220kPa?</p>	<ol style="list-style-type: none"> <li>1. Check for leakages from hoses, hose joints</li> <li>2. Check Fuel Pump</li> <li>3. Check Pressure Regulator</li> </ol>	<ol style="list-style-type: none"> <li>1. Clogged Filter</li> <li>2. Kink/ Blockage in Fuel Hoses</li> <li>3. Check Regulator</li> </ol>

### 3. Fuel Module Removal:

- Relieve fuel pressure in fuel lines referring to the 'Fuel Pressure Relief Procedure' provided in this section.
- Disconnect negative cable at battery.
- Disconnect fuel module wire coupler.
- Drain the fuel in fuel tank thru fuel filler with help of hand pump (siphon). Collect the fuel in approved container for contamination and safety.
- Disconnect the fuel hoses from fuel module by using standard tools
- Remove the fuel tank from vehicle.
- Place the fuel tank with bottom up condition. Care to be taken not to cause any scratches/ damages on fuel tank.
- Open the fuel module mounting bolts.
- Take out fuel module assembly from fuel tank with care
- Care to be taken not to damage the strainer while removing fuel module from tank.

### 4. Fuel Module Installation:

- Replace the fuel module gasket in fuel module assembly with a new one. Old/ used gaskets can cause leakages.
- Fold strainer towards fuel pump and insert fuel module in tank opening with care. Care should be taken not to cause any damages on strainer.

#### NOTE

**Fuel Module Orientation:** Fuel module bolts not symmetrical and can be mounted only in the intended direction. Regulator side should be facing the Fuel Tank rear side. Make sure that the fuel tank surface at module mounting area is clean and free of surface defects.



## ENGINE MANAGEMENT SYSTEM

- Place the bolts on module cover and tighten the bolts gradually in star pattern sequence to apply equal compression on gasket. It is shown in figure as below. Bolt Tightening Torque: 3~4 Nm.

Fuel module is installed with special bolts (step bolts). Use designated bolts only. Follow the tightening torque and tightening sequence instruction. Over torque and miss-sequence can cause unequal compression of gasket and leakage.

- Install the fuel tank to vehicle.
- Connect for fuel hoses with suitable hose clamps.
- Connect fuel module coupler.
- Follow "Fuel Leakage Check Procedure" to check any leakage before the engine is started.

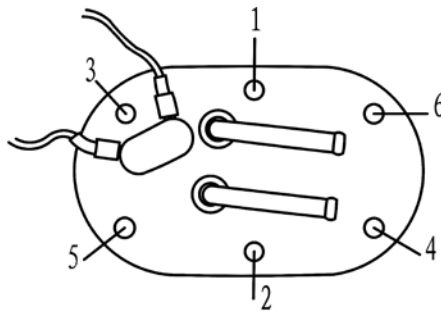

Mounting Bolts – Star Tightening Pattern

### 5. Pressure Regulator Assembly Replacement:

- Remove the regulator retainer from module.
- Apply gradual pull force on retainer to avoid any personal injury due to spring action of retainer.
- Take out the pressure regulator assembly from module.
- Do not hit/ damage on the regulator dome and crimping portion.
- Lubricate the O-rings in new pressure regulator assembly with recommended lubrication oils as mentioned in Table no: 3. Lubrication oil is applied only for ease of regulator assembly.
- Make sure that 2 O-rings (one is bigger diameter the other is smaller diameter) are assembled in pressure regulator.
- Place the pressure regulator on module at regulator pod. Push the regulator gently in the pod.
- Do not hit/ damage on the regulator dome and crimping portion. This will disturb the pressure setting.
- Assemble the retainer on the regulator pod
- Replace the gasket, module with new gasket provided in the kit.

### 6. Fuel Pressure Relief Procedure:

#### **NOTE**

**This work must not be done when engine is hot. If done so, it may cause adverse effect to catalyst (if equipped)**

## ENGINE MANAGEMENT SYSTEM

After making sure that engine is cold, relieve fuel pressure as follows.

- Place vehicle gear in 'Neutral'.
- Disconnect fuel module electrical coupler from vehicle harness.
- Start engine and run till it stops due to lack of fuel. Repeat ignition key ON and OFF for 2 ~ 3 times of about 3 seconds each time to relieve fuel pressure in lines. Fuel Connections are now safe for servicing.
- Upon the completion of servicing, Connect Fuel Module Connector to Vehicle Harness.

### 7. Fuel Leakage Check Procedure:

After performing any service on fuel system, check to make sure that there are no fuel leakages as below.

- Fill about 3 ~ 5 liters of fuel in tank.
- Turn Ignition key to ON position for 3 seconds (to operate fuel pump) and then turn to OFF position. Repeat this for 3 ~ 4 times to apply fuel pressure in fuel lines.
- In this state, check to see that there are no fuel leakage from any part of fuel system (Fuel Tank, Hoses, Hose Joints, etc)

### 8. Handling – DOs and DONTs:

<b>FUEL MODULE HANDLING</b>	
<b>ACTION</b>	<b>REASON</b>
<b>DO NOT:</b> Drop Fuel Module on Floor	Could cause internal damage to Fuel Pump.
<b>DO NOT:</b> Run Fuel Pump Dry (without fuel at pump inlet/ strainer) ensure atleast 3 litres of gasoline is present in the fuel tank	Caused internal damage to Fuel Pump
<b>DO NOT:</b> Damage the strainer during servicing, insertion of fuel module in fuel tank	Contamination enters fuel pump thru damaged strainer damages the Fuel Pump
<b>DO NOT:</b> Disassemble Fuel Pump and regulator internal parts out side Delphi premises. <b>DO NOT:</b> Do any adjustments on pressure regulator and pump except for replacement.	Warranty void.
<b>DO NOT:</b> Use module harness for hold/ carry fuel module. <b>DO NOT:</b> Pull Wiring Harness in vertical direction to module cover	Wiring Harness Breakage/ Fuel Pump Power disconnection
<b>DO NOT:</b> Use damaged/ distorted hose clamps.	Can cause fuel seepage/ leakage.

## ENGINE MANAGEMENT SYSTEM

<b>DO NOT:</b> Use Fuel Module if the strainer with excessive damage/ cut.	Contamination enters fuel pump thru damaged strainer damages the Fuel Pump
<b>DO NOT:</b> Use Fuel Pump for draining fuel in fuel tank.	Not intended function of fuel module.
<b>DO NOT:</b> Use module mounting bolts for mounting other components.	Affects fuel module sealing.
<b>DO NOT:</b> Damage fuel pump harness while servicing fuel module.	Damaged terminals will cause intermittent/ No contact for power supply.
<b>DO NOT:</b> Force hand pump towards fuel module while draining fuel from tank.	To avoid any damages on fuel module.
<b>DO :</b> Ensure that there are no damages to fuel pipes while servicing fuel module	Can cause fuel seepage/ leakage.
<b>DO:</b> Use genuine module gasket only.	Spurious gaskets can cause leakages.
<b>DO:</b> Use designated hose clamps.	To ensure no leakages/ seepages thru hose joint.
<b>DO:</b> Clamp fuel module harness to vehicle chassis	Clamp provides mechanical support for wiring harness in vibrations.
<b>DO:</b> Use only standard gasoline for operating vehicle/ module.	Fuel Module is intended to run in standard gasoline. Adulterated fuel can cause fuel module premature failures which are not covered under warranty.
<b>DO:</b> Change the fuel filter at recommended intervals.	Clogged fuel filter will cause restriction in fuel flow and can cause flow reduction.
<b>DO:</b> Use fuel filters supplied/ recommended fuel filters only.	Spurious fuel filters causes damages to injector, regulator and fuel pump performance.
<b>DO:</b> Ensure that the hoses are routed properly and there are no kinks / rubbing with other components.	Improper routing, kinks and fouling of hoses with other components causes hose damage
<b>DO:</b> Ensure that always sufficient fuel till the strainer height	Avoids Pump running in dry
<b>DO:</b> Replace two O-rings along with replacement/ re-installation of pressure regulator.	For proper functioning of regulator.
<b>DO:</b> Use care during connection of harness to module coupler.	Avoid terminal damage.
<b>DO:</b> Return any dropped, damaged, or suspect material with a tag that describes the problem.	Ensure fast and correct diagnosis of root cause.

## ENGINE MANAGEMENT SYSTEM

### EMS FAULT DIAGNOSIS

#### EME Fault Diagnosis

When fault comes up, the odometer's clock will turn into a number, which is a fault code, find out the cause with this number; press clock button, then it will turn back to clock mode, and five seconds later, the fault code will show again.

#### Fault code list

System or Component	DTC Number	DTC Description	Related Calibration
Manifold Absolute Pressure Sensor (MAP)	0107	MAP Circuit Low Voltage or Open	KsDGDM_MAP_ShortLow
	0108	MAP Circuit High Voltage	KsDGDM_MAP_ShortHigh
Intake Air Temperature Sensor (IAT)	0112	IAT Circuit Low Voltage	KsDGDM_IAT_ShortLow
	0113	IAT Circuit High Voltage or Open	KsDGDM_IAT_ShortHigh
Coolant/Oil Sensor	0117	Coolant/Oil Temperature Sensor Circuit Low Voltage	KsDGDM_CoolantShortLow
	0118	Coolant/Oil Temperature Sensor Circuit High Voltage or Open	KsDGDM_CoolantShortHigh
Throttle Position Sensor (TPS)	0122	TPS Circuit Low Voltage or Open	KsDGDM_TPS_ShortLow
	0123	TPS Circuit High Voltage	KsDGDM_TPS_ShortHigh
Oxygen Sensor	0131	O2S 1 Circuit Low Voltage	KsDGDM_O2_1_ShortLow
	0132	O2S 1 Circuit High Voltage	KsDGDM_O2_1_ShortHigh
Oxygen Sensor Heater	0031	O2S Heater Circuit High Voltage	KsDGDM_O2_HeaterShortHigh
	0032	O2S Heater Circuit Low Voltage	KsDGDM_O2_HeaterShortLow
Fuel Injector	0201	Injector 1 Circuit Malfunction	KsDGDM_INJ_CYL_A_Fault
	0202	Injector 2 Circuit Malfunction	KsDGDM_INJ_CYL_B_Fault
Fuel Pump Relay (FPR)	0230	FPR Coil Circuit Low Voltage or Open	KsDGDM_FPP_CircuitShortLow
	0232	FPR Coil Circuit High Voltage	KsDGDM_FPP_CircuitShortHigh
Crankshaft Position	0336	CKP Sensor Noisy Signal	KsDGDM_CrankNoisySignal
Sensor (CKP)	0337	CKP Sensor No Signal	KsDGDM_CrankNoSignal
Ignition Coil	0351	Cylinder 1 Ignition Coil Malfunction	KsDGDM_EST_A_Fault
	0352	Cylinder 2 Ignition Coil Malfunction	KsDGDM_EST_B_Fault
Idle Control System	0505	Idle Speed Control Error	KsDGDM_IdleControl

## ENGINE MANAGEMENT SYSTEM

<b>System Voltage</b>	0562	System Voltage Low	KsDGDM_SysVoltLow
	0563	System Voltage High	KsDGDM_SysVoltHigh
<b>MIL</b>	0650	MIL Circuit Malfunction	KsDGDM_MIL_Circuit
<b>Tachometer</b>	1693	Tachometer Circuit Low Voltage	KsDGDM_TAC_Circuit_Low
	1694	Tachometer Circuit High Voltage	KsDGDM_TAC_Circuit_High
<b>Oxygen Sensor 2</b>	0137	O2S 2 Circuit Low Voltage	KsDGDM_O2_2_ShortLow
	0138	O2S 2 Circuit High Voltage	KsDGDM_O2_2_ShortHigh
<b>Oxygen Sensor Heater 2</b>	0038	O2S Heater 2 Circuit High Voltage	KsDGDM_O2_HeaterShortHigh
	0037	O2S Heater 2 Circuit Low Voltage	KsDGDM_O2_HeaterShortLow
<b>Vehicle Speed Sensor</b>	0500	VSS No Signal	KsDGDM_VSS_NoSignal
<b>Park Neutral Switch Diag</b>	0850	Park Neutral Switch Error	KsDGDM_ParkNeutralSwitch
<b>CCP</b>	0445	CCP short to high	KsDGDM_CCP_CircuitShortHigh
	0444	CCP short to low/open	KsDGDM_CCP_CircuitShortLow
<b>BLM MaxAdapt</b>	0171	BLM Max Adapt(Kohler Special)	KsFDIAG_BLM_MaxAdapt
<b>BLM MinAdapt</b>	0172	BLM Min Adapt(Kohler Special)	KsFDIAG_BLM_MinAdapt
<b>PE system Lean</b>	P0174	PE syst Lean(Kohler Special)	KsFDIAG_PESystLean

## TROUBLESHOOTING

---

**NOTE:**

The following trouble, not including all possible troubles, is a help for trouble guide. Please refer to relevant contents for the inspection, adjustment and replacement of part.

---

### STARTING FAILURE/HARD STARTING

<b>FUEL SYSTEM</b>	
<b>Fuel tank</b>	<ol style="list-style-type: none"> <li>1、 No oil</li> <li>2、 Fuel filter is clogged</li> <li>3、 Fuel pump filter net is clogged</li> <li>4、 Breather tube is clogged</li> <li>5、 Fuel is deteriorated or polluted</li> </ol>
<b>Fuel pump</b>	<ol style="list-style-type: none"> <li>1、 Clogged fuel hose</li> <li>2、 Damaged vacuum hose</li> </ol>
<b>Air filter</b>	Clogged air filter element
<b>Gasoline filter</b>	Block up
<b>ELECTRICAL SYSTEM</b>	
<b>Spark plug</b>	<ol style="list-style-type: none"> <li>1、 Improper plug gap</li> <li>2、 Worn electrodes</li> <li>3、 Wire between terminals broken</li> <li>4、 Wrong Spark plug heat value</li> <li>5、 Faulty spark plug cap</li> <li>6、 High voltage wires strapped on frame cause shortage of high pressure ignition energy</li> </ol>
<b>EFI system</b>	<ol style="list-style-type: none"> <li>1、 Broken ECU</li> <li>2、 Clogged nozzle or the rupture the line from nozzle to ECU</li> <li>3、 Damage of engine speed signal sensor</li> <li>4、 Rupture of the line from engine speed signal sensor to ECU</li> <li>5、 Broken inlet pressure or temperature sensor or damaged line to ECU</li> <li>6、 Broken air throttle or damage line to ECU.</li> <li>7、 Broken vice line (cable) of electrical injection</li> </ol>
<b>Switches and wires</b>	<ol style="list-style-type: none"> <li>1、 Broken main cable</li> <li>2、 Broken main switch</li> </ol>

## TROUBLESHOOTING

<b>Starter motor</b>	<ol style="list-style-type: none"> <li>1、 Faulty starter motor</li> <li>2、 Faulty starter relay</li> <li>3、 Faulty overrunning clutch in engine</li> <li>4、 Broken main switch</li> <li>5、 Broken main fuse</li> </ol>
<b>Battery</b>	<ol style="list-style-type: none"> <li>1、 Low battery voltage</li> <li>2、 Faulty battery</li> </ol>
<b>COMPRESSION SYSTEM</b>	
<b>Cylinder and cylinder head</b>	<ol style="list-style-type: none"> <li>1、 Loose spark plug</li> <li>2、 Loose cylinder head or cylinder</li> <li>3、 Broken cylinder head gasket</li> <li>4、 Broken cylinder gasket</li> <li>5、 Worn, damaged or seized cylinder</li> </ol>
<b>Piston and piston rings</b>	<ol style="list-style-type: none"> <li>1、 Improperly installed piston ring</li> <li>2、 Worn, fatigued or broken piston ring</li> <li>3、 Seized piston ring</li> <li>4、 Seized or damaged piston</li> </ol>
<b>Valve, camshaft and crankshaft</b>	<ol style="list-style-type: none"> <li>1、 Improperly sealed valve</li> <li>2、 Improperly contacted valve and valve seat</li> <li>3、 Improper valve timing</li> <li>4、 Broken valve spring</li> <li>5、 Seized camshaft</li> </ol>
<b>Crankcase and crankshaft</b>	<ol style="list-style-type: none"> <li>1、 Improperly seated crankcase</li> <li>2、 Seized crankshaft</li> </ol>
<b>Valve train</b>	<ol style="list-style-type: none"> <li>1、 Improperly adjusted valve clearance</li> <li>2、 Improperly adjusted valve timing</li> </ol>

## POOR IDLE SPEED PERFORMANCE

<b>POOR IDLE SPEED PERFORMANCE</b>	
<b>EFI system</b>	<ol style="list-style-type: none"> <li>1、 Broken ECU</li> <li>2、 Clogged nozzle or the rupture the line from nozzle to ECU</li> <li>3、 Damage of engine speed signal sensor</li> <li>4、 Rupture of the line from engine speed signal sensor to ECU</li> <li>5、 Broken inlet pressure or temperature sensor or damaged line to ECU</li> <li>6、 Broken air throttle or damage line to ECU.</li> <li>7、 Broken vice line (cable) of electrical injection</li> </ol>

## TROUBLESHOOTING

<b>Electrical system</b>	<ol style="list-style-type: none"> <li>1、 Faulty ignition plug</li> <li>2、 The performace of speed sensor become poor</li> <li>3、 Faulty ignition coil</li> </ol>
<b>Valve train</b>	Improperly adjusted valve clearance
<b>Air filter</b>	Clogged air filter element

### POOR MEDIUM AND HIGH-SPEED PERFORMANCE

<b>POOR MEDIUM AND HIGH-SPEED PERFORMANCE</b>	
<b>EFI system</b>	<ol style="list-style-type: none"> <li>1、 Broken ECU</li> <li>2、 The performance of speed signal sensor become poor</li> <li>3、 The main nozzle clog or loose</li> <li>4、 Spoiled or pollute oil</li> <li>5、 Broken inlet pressure / temperature sensor</li> <li>6、 Air throttle position sensor loose</li> </ol>
<b>Air filter</b>	Clogged air filter element
<b>Muffler</b>	Clogged muffler
<b>Set out</b>	The reverse signal error trigger

### FAULTY GEAR SHIFTING

<b>SHIFT LEVER DOES NOT MOVE</b>	
<b>Shift drum, shift forks</b>	<ol style="list-style-type: none"> <li>1、 Groove jammed with impurities</li> <li>2、 Seized shift fork</li> <li>3、 Bent shift fork guide bar</li> <li>4、 Broken shift guide</li> </ol>
<b>Transmission</b>	<ol style="list-style-type: none"> <li>1、 Seized transmission gear</li> <li>2、 Incorrectly assembled transmission</li> </ol>
<b>Shift guide</b>	<ol style="list-style-type: none"> <li>1、 Broken shift guide mechanism</li> <li>2、 Broken shift flexible shaft</li> </ol>
<b>JUMPS OUT OF GEAR</b>	
<b>Shift forks</b>	Worn shift fork
<b>Shift drum</b>	<ol style="list-style-type: none"> <li>1、 Improper thrust play</li> <li>2、 Worn shift drum groove</li> </ol>
<b>Transmission</b>	Worn gear dog



# TROUBLESHOOTING

## ENGINE OVERHEATING

<b>OVERHEATING</b>	
<b>Ignition system</b>	1、 Improper spark plug gap 2、 Improper spark plug heat range
<b>Fuel system</b>	1、 Improper fuel level 2、 Clogged air filter element
<b>Compression system</b>	Heavy carbon deposit
<b>Engine oil</b>	1、 Improper oil level 2、 Improper oil viscosity 3、 Inferior oil quality
<b>Brake</b>	Brake drag
<b>Cooling system</b>	1、 Low coolant level 2、 Clogged or damaged radiator 3、 Damaged or faulty water pump 4、 Faulty fan motor 5、 Faulty thermo switch
<b>Oil cooling system</b>	Clogged or damaged oil cooler

## FAULTY BRAKE

<b>POOR BRAKING EFFECT</b>	
<b>Disc brake</b>	1、 Worn brake pads 2、 Worn disc 3、 Air in brake fluid 4、 Leaking brake fluid 5、 Faulty master cylinder kit cup 6、 Faulty caliper kit sea 7、 Loose union bolt 8、 Broken brake hose and pipe 9、 Oily or greasy disc/brake pads 10、 Improper brake fluid level

## TROUBLESHOOTING

---

### SHOCK ABSORBER MALFUNCTION

<b>Loss of damping function</b>	
<b>Shock absorber</b>	<ol style="list-style-type: none"> <li>1、 Bent or damaged damper rod</li> <li>2、 Damaged oil seal lip</li> <li>3、 Fatigued shock absorber spring</li> </ol>

### UNSTABLE HANDLING

<b>UNSTABLE HANDLING</b>	
<b>Steering column</b>	Improperly installed or bent
<b>Steering</b>	<ol style="list-style-type: none"> <li>1、 Incorrect toe-in</li> <li>2、 Bent steering shaft</li> <li>3、 Improperly installed steering shaft</li> <li>4、 Damaged bearing</li> <li>5、 Bent tie-rods</li> </ol>
<b>Tires</b>	<ol style="list-style-type: none"> <li>1、 Uneven tire pressures on both sides</li> <li>2、 Incorrect tire pressure</li> <li>3、 Uneven tire wear</li> </ol>
<b>Rim</b>	<ol style="list-style-type: none"> <li>1、 Deformed wheel</li> <li>2、 Loose bearing</li> <li>3、 Bent or loose wheel axle</li> </ol>
<b>Frame</b>	<ol style="list-style-type: none"> <li>1、 Bent</li> <li>2、 Damaged frame</li> </ol>
<b>Suspension</b>	<ol style="list-style-type: none"> <li>1、 Over worn or loosen main knuckle ball stud</li> <li>2、 Bent rocker</li> <li>3、 Broken shock absorber</li> <li>4、 Broken buffer rubber of rocker shaft</li> </ol>

### LIGHTING SYSTEM

<b>HEAD LIGHT IS OUT OF WORK</b>	
<b>Head light is out of work</b>	<ol style="list-style-type: none"> <li>1、 Improper bulb</li> <li>2、 Too many electric accessories</li> <li>3、 Hard charging( broken stator coil and/or faulty rectifier/regulator)</li> <li>4、 Incorrect connection</li> <li>5、 Improperly grounded</li> <li>6、 Bulb life expired</li> </ol>

## TROUBLESHOOTING

---

<b>BULB BURNT OUT</b>	
<b>Bulb burnt out</b>	<ol style="list-style-type: none"><li>1、 Improper bulb</li><li>2、 Faulty battery</li><li>3、 Faulty rectifier/regulator</li><li>4、 Improperly grounded</li><li>5、 Faulty main and/or lights switch</li><li>6、 Bulb life expired</li></ol>
<b>ERROR DISPLAY OF METER</b>	
<b>Wrong Speed</b>	<ol style="list-style-type: none"><li>1、 Then sensor on rear axle is damaged or polluted by iron powder</li><li>2、 The connection between sensor to meter is wrong.</li><li>3、 Broken meter</li></ol>

# **SERVICE MANUAL**

## **SUPPLEMENTARY**

# **750UTV**

## 750UTV SPECIFICATION

### SPECIFICATIONS

#### General Specifications

Item	Standard
<b>Engine :</b>	
Model	HS1102MV
Engine type	Liquid cooled 4-stroke, Water cool
Cylinder arrangement	Forward-inclined single cylinder
Displacement	735cc
Bore×stroke	102.0×90.0
Compression ratio	9.7±0.1:1
Starting system	Electric starter
Lubrication system	Wet sump
<b>Throttle</b>	
Type/quantity	D46-U
<b>Spark plug</b>	
Type/manufacturer	DRPR7E
Spark plug gap	0.6-0.7 mm (0.024-0.028in)

# MAINTENANCE AND ADJUSTMENT OF THE 750UTV

## ENGINE

### Adjusting the valve clearance

#### **NOTE:**

- The valve clearance must be adjusted when the engine is cool to the touch.
- Adjust the valve clearance when the piston is at the Top Dead Center (TDC) on the compression stroke.

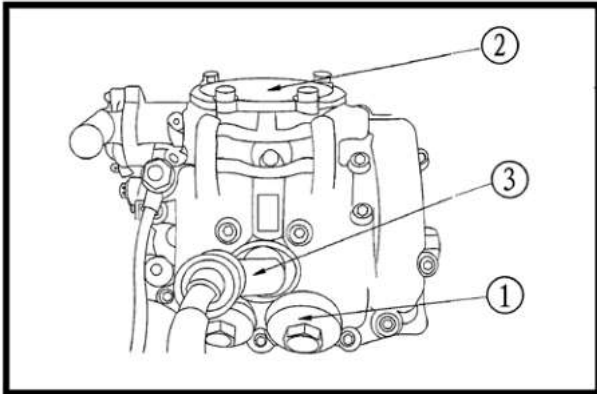

#### 1. Remove following parts:

- ① Valve cover(intake)
- ② Valve cover(exhaust)
- ③ spark plug cap
- ④ spark plug

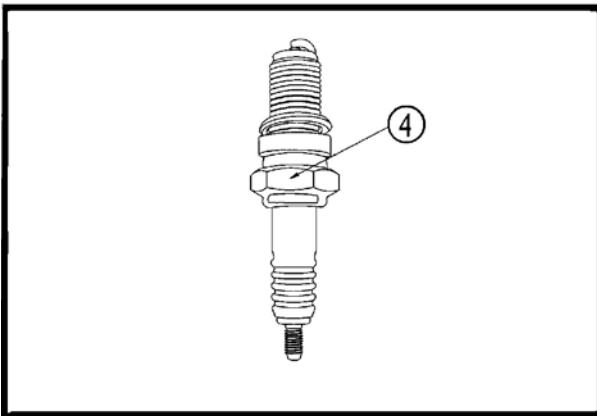

#### 2. Remove the cooling fan:

- ① Fan cover

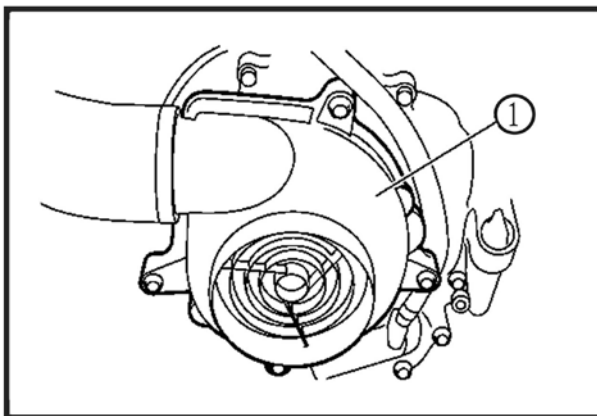

## MAINTENANCE AND ADJUSTMENT OF THE 750UTV

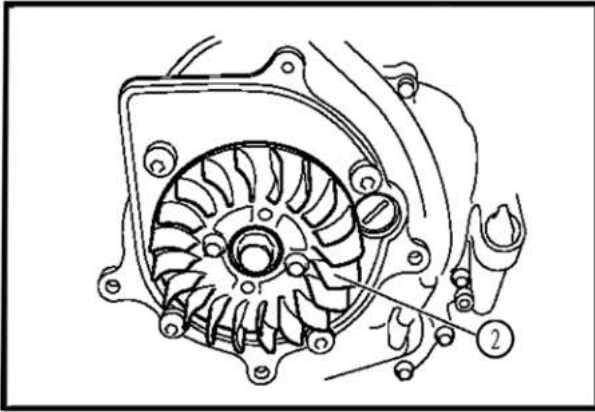

② Fan impeller

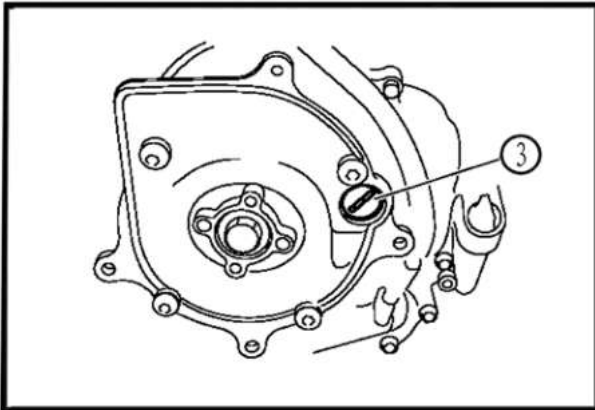

③ As manhole covers

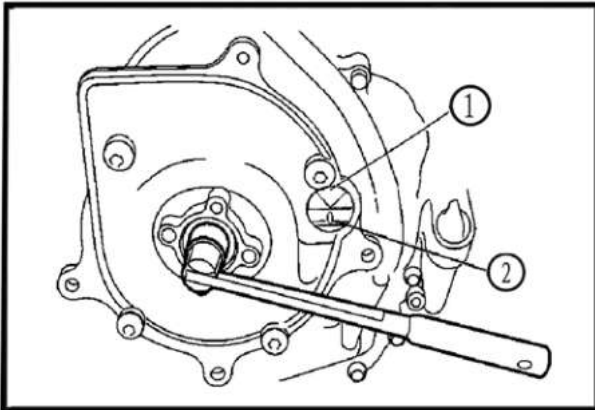

### 3. calibration

- Wrench to counterclockwise rotation crankshaft
- According to the rotor turning counterclockwise, rotor turn to mark the dead spots ② of crank box, namely ①: the dead point position is compressed.

### 4. Check:

- valve clearance
- Beyond the standard → Adjust.

#### Valve clearance (cold)

##### Intake

**0.10 ~ 0.15 mm**  
(0.0039 ~ 0.0059 in)

##### Exhaust

**0.15 ~ 0.20 mm**  
(0.0059 ~ 0.0079 in)

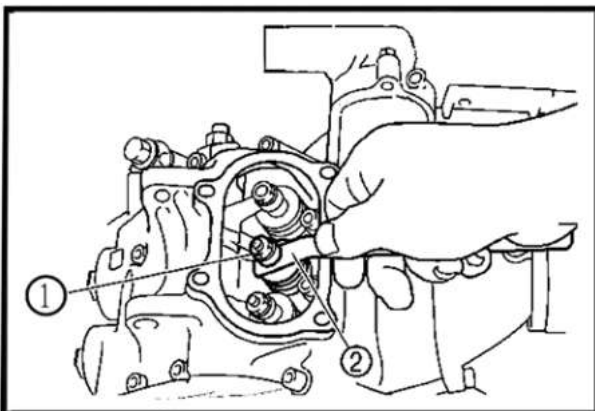

### 5. Adjust:

valve clearance

- ① Lock nut
- ② Valve thickness gauge (gap Regulation)
- ③ Regulator
- ④ Adjust tools

## MAINTENANCE AND ADJUSTMENT OF THE 750UTV

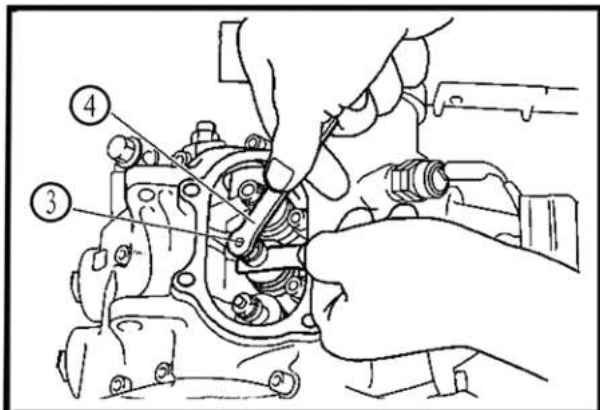

- Loosen the locknut ①.
- Insert a thickness gauge ③ between the adjuster end and the valve end.
- Turn the adjuster ③ clockwise or counterclockwise with the tappet adjusting tool ④
- In order to avoid the regulator, adjust rotation together after fastening tool fixed lock nut.

14Nm (1.4kg.m)

- Measuring clearance rules with the valve clearance.
- If the gap beyond the standard value, repeat the above steps until the correct gap.

### 6. Install all removed parts

According to remove the reverse order for installation

- ① Engine fan components
- ② Fan cover
- ③ spark plug
- ④ Valve cover (exhaust)
- ⑤ Valve cover (intake)
- ⑥ Lower the cargo bed.
- ⑦ console
- ⑧ seat

Refer to "SEATS," in chapter 5.

### IDLE ADJUSTMENT

1. Starting engines, thorough warm machine

2. Remove:

- Lift the cargo bed up.
- seat
- console

Refer to "SEATS " in chapter 5.

3. Install

- Engine tachometer

4. Confirm speed

- Standard Engine Idle speed

**Engine idle speed**  
**1,400 ±100 r/min**

Beyond the standard → Adjust.

5. Adjust:

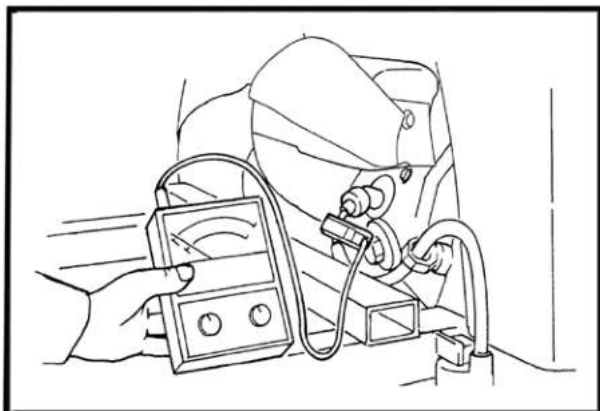



## MAINTENANCE AND ADJUSTMENT OF THE 750UTV

- Engines idle speed adjustment
  - a. Turn the throttle stop screw in or out until the specified idle speed is obtained.

### **NOTE:**

**Don't lock screw too tight**

Turning in	Idle speed becomes higher.
Turning out	Idle speed becomes lower.

6. sever:
  - Tachometer
7. Lower the cargo bed.
8. Install:
  - console
  - seat

### ADJUSTING THE THROTTLE

#### **NOTE:**

Throttle cable free play should be adjusted properly before adjusting the engine idle speed.

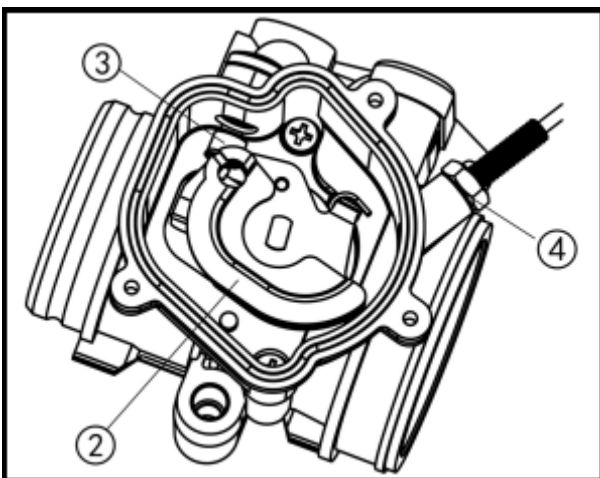
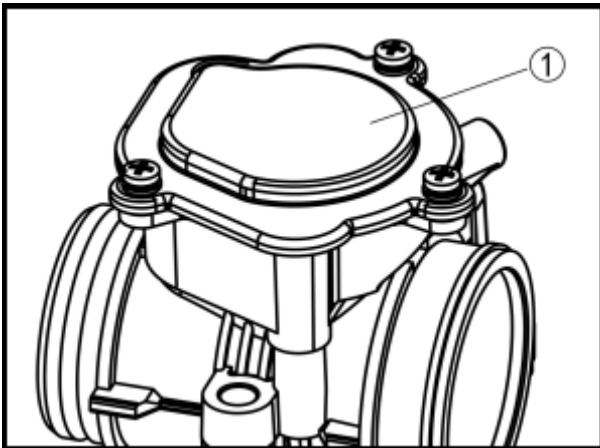

- ① External shaft cover
- ② Throttle Valves
- ③ Idle adjusting lever
- ④ Adjusting Screw

1. Remove following parts:
  - seat
  - console
2. Remove:
  - Throttle valve cover ①
3. Check:
  - throttle cable Slack ④ → Remove the slack
4. Adjust:
  - throttle cable
    - a. Will loosen the locknut ③.
    - b. Adjusted by regulator

## MAINTENANCE AND ADJUSTMENT OF THE 750UTV

Turning in	Slack is increased.
Turning out	Slack is decreased.

c. Tighten the locknut.

### **NOTE:**

After adjustment throttle pressure on the accelerator cable several times, ensuring the throttle ③, then close completely loosen the accelerator pedal .

5. Install:

- console
- seat

### CHECKING THE SPARK PLUG

1. Lift the cargo bed up.

2. Remove:

- pull out the spark plug cap ① and remove the spark plug by sleeve

3. Check:

- spark plug type  
Incorrect → Replace.

**Standard spark plug  
DCPR7E/NGK**

4. Check:

- electrode ①

To check if it is burned blunt or much carbon is there, then check the pole clearance by thickness gauge. It is qualified if the pole clearance is between 0.6 to 0.7mm. Otherwise it should be adjusted.

Wear/damage → Replace.

- insulator ②

Abnormal color → Replace.

Normal color is a medium-to-light tan color.

5. Clean the spark plug with a spark plug cleaner or wire brush.

6. Install:

- spark plug

**18 Nm -20 Nm (1.8 m · kg, 13 ft · lb)**

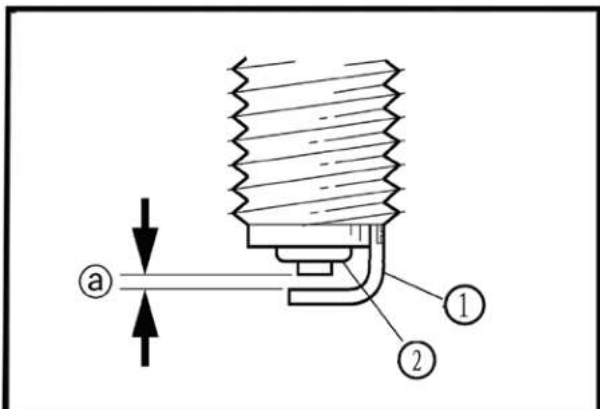
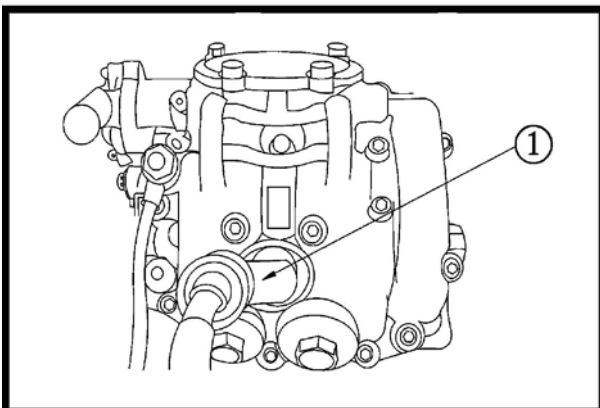

## MAINTENANCE AND ADJUSTMENT OF THE 750UTV

Then hook up the spark plug cap.

### **NOTE:**

**Before installing a spark plug, clean the gasket surface and plug surface.**

7. Lower the cargo bed.

### CHECKING THE IGNITION TIMING

### **NOTE:**

**Engine idle speed and throttle cable free play should be adjusted properly before checking the ignition timing.**

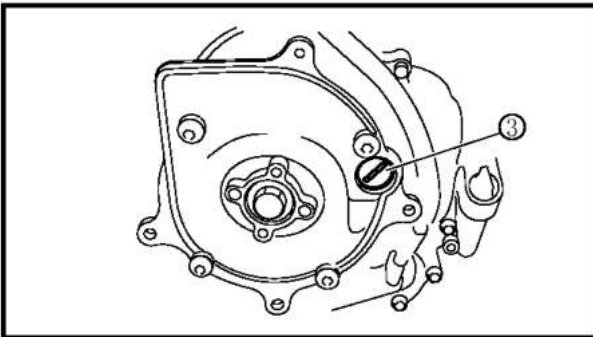
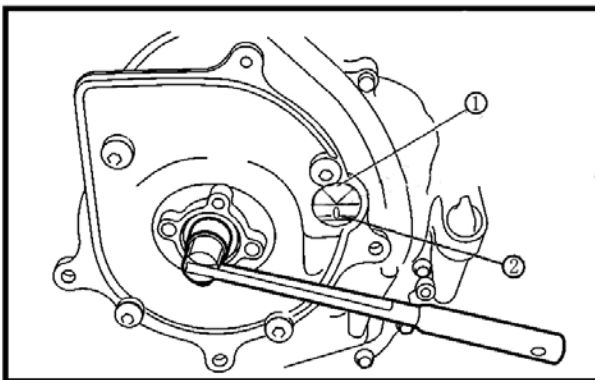
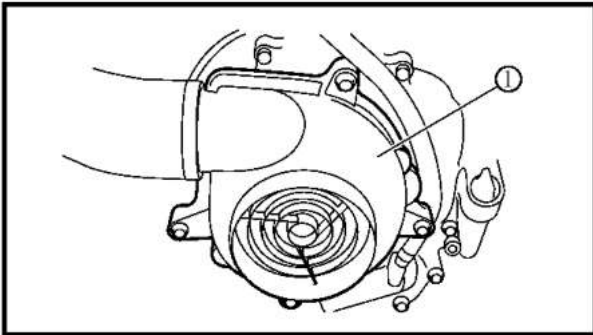

1. Remove:

- seat
- console

Refer to "SEATS" in chapter 5.

2. Lift the cargo bed up.

3. Attach:

- tachometer
- timing light  
(to the spark plug lead)

4. Remove:

Remove the cooling fan  
reference of adjusting valve clearance.

5. Check:

- ignition timing

a. Warm up the engine and keep it at the  
specified speed

### **Engine speed**

**1,400 ~ 1,500 r/min**

b. Remove the timing plug ③

c. Visually check the stationary pointer ① to  
verify it is within the required firing range ②  
indicated on the flywheel.

Incorrect firing range → Check the pulser coil  
assembly.

d. Install the timing plug.

6. Install:

## MAINTENANCE AND ADJUSTMENT OF THE 750UTV

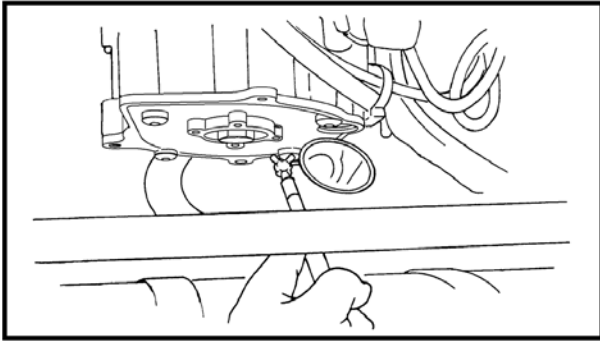

- Engine cooling fan

**7 Nm (0.7 m · kg, 5.1 ft · lb)**

7. Install:

- ① Air shroud

**10 Nm (1.0 m · kg, 7.2 ft · lb)**

8. Detach:

- timing light
- tachometer

9. Lower the cargo bed.

10. Install:

- console
- seat

Refer to “SEATS” in chapter 5.

### MEASURING THE COMPRESSION PRESSURE

#### **NOTE:**

**Insufficient compression pressure will result in a loss of performance.**

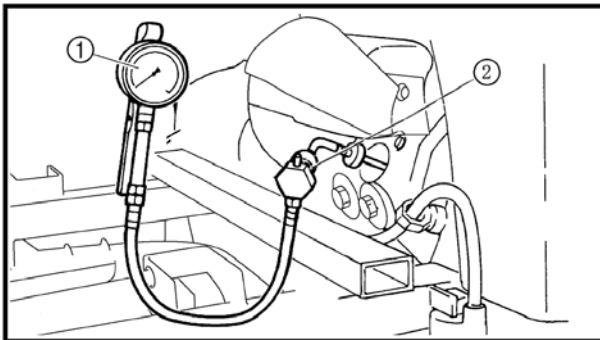

1. Start the engine and let it warm up for several minutes.
2. Stop the engine and remove the spark plug.
3. Assemble the compression pressure meter ① and joint utensil ② on the hole of the spark plug
4. check standard value

**standard compression pressure data**

**1200Kpa (12kg/ cm<sup>2</sup>)-1000r/min**

5. read the highest data on the compression pressure meter
  - Above the maximum pressure:  
Check the cylinder head, valve surfaces, and piston crown for carbon deposits.
  - Below the minimum pressure:  
Check the accumulation carbon in the firebox of the cylinder head and accumulation carbon on the piston head.
  - Refer to the table below.

## MAINTENANCE AND ADJUSTMENT OF THE 750UTV

<b>Compression pressure(with oil introduced into cylinder)</b>	
<b>Reading</b>	<b>Diagnosis</b>
<b>Higher than without oil</b>	<b>Worn or damaged pistons</b>
<b>Same as without oil</b>	<b>Defective ring(s), valves, cylinder head gasket or piston is possible.</b>

<p><b>Compression pressure (at sea level)</b></p> <p><b>Standard: 1,324Kpa</b> (13.24 kg/cm<sup>2</sup>, 188.31Psi)</p> <p><b>Minimum: 1,150Kpa</b> (11.5 kg/cm<sup>2</sup>, 163.57Psi)</p> <p><b>Maximum: 1,480Kpa</b> (14.8 kg/cm<sup>2</sup>, 210.50Psi)</p>
---

- Crank over the engine with the electric starter (be sure the battery is fully charged) with the throttle wide-open until the compression reading on the gauge stabilizes.

**NOTE:**

**When cranking the engine, ground the spark plug lead to prevent sparking.**

4. Install:

- spark plug

<b>18 Nm-20Nm (1.8 m · kg, 13 ft · lb)</b>
--

5. Lower the cargo bed.

**CHECKING THE ENGINE OIL LEVEL**

1. Place the vehicle on a level surface

2. Remove:

- driver seat
- passenger seat
- console

Refer to “SEATS” in chapter 5.

3. Check:

- engine oil level

Oil level should be between the maximum

① and minimum ② marks.

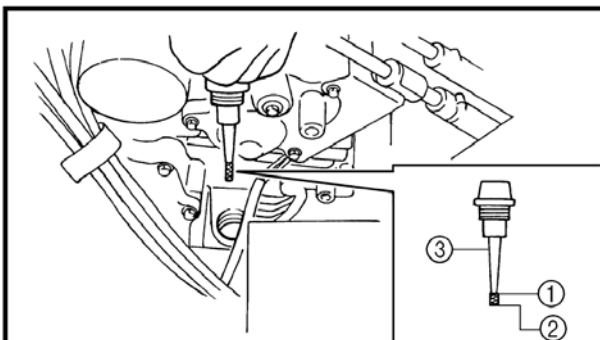

# MAINTENANCE AND ADJUSTMENT OF THE 750UTV

Oil level low → Add oil to the proper level.

**NOTE:**

Do not screw the dipstick 3 in when checking the oil level.

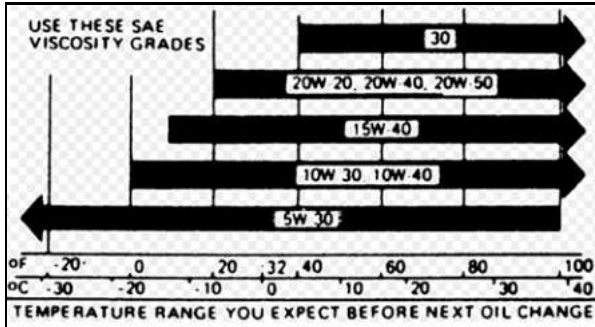

Recommended oil

Follow the left chart.

**NOTE:**

Recommended oil classification:  
API-SJ & JASO/MA

**NOTE:**

Do not allow foreign material to enter the crankcase.

4. Start the engine and let it warm up for several
5. Stop the engine and check the oil level again.

**NOTE:**

Wait a few minutes until the oil settles before checking the oil level.

**NOTE:**

Never remove the dipstick just after high speed operation because the heated oil could spurt out. Wait until the oil cools down before removing the dipstick.

6. Install:

- console
- seat

Refer to "SEATS" in chapter 5.

## CHANGING THE ENGINE OIL

Place the vehicle on a level surface.

1. Start the engine and let it warm up for several minutes.
2. Stop the engine and place an oil pan under the engine.
3. Remove:
  - seat
  - console
4. Remove:
  - engine oil filler plug (dipstick) ①

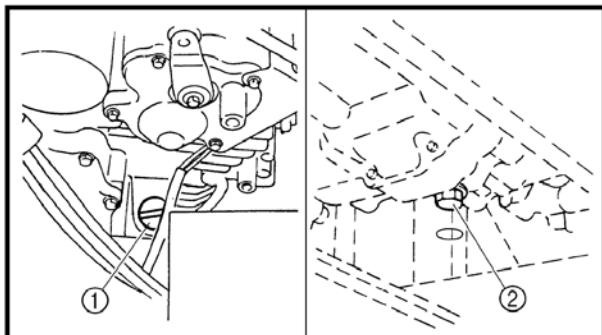

## MAINTENANCE AND ADJUSTMENT OF THE 750UTV

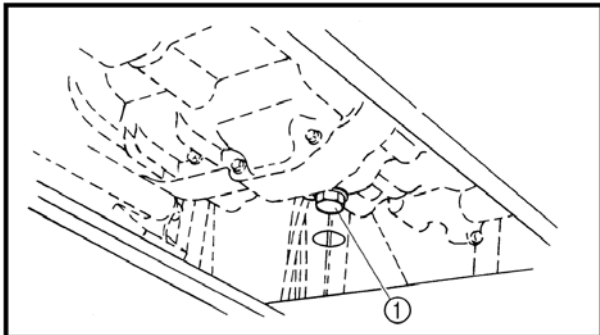
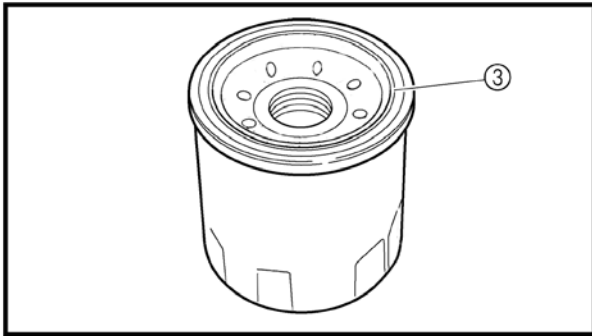
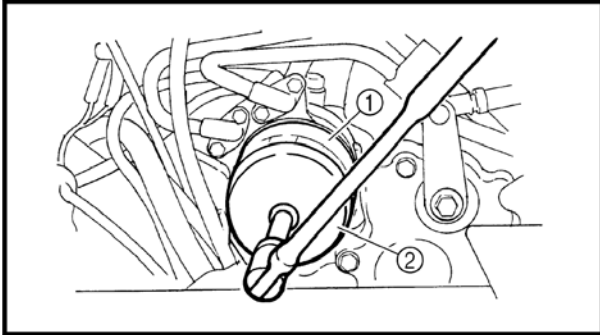

- engine oil drain bolt ① Drain the engine oil from the crankcase.

5. If the oil filter cartridge is also to be replaced, perform the following procedure.

- Remove the oil filter cartridge ① With an oil filter wrench ②.
- Lubricate the O-ring cartridge with a thin coat of lithium-soap-based grease.

### NOTE:

Make sure that the O-ring ③ is positioned correctly in the groove of the oil filter cartridge.

- Tighten the new oil filter cartridge to specification with an oil filter wrench.

### Oil filter cartridge

17 Nm (1.7 m · kg, 12 ft · lb)

6. Install:

- engine oil drain bolt ①

7. Fill:

- Before the oil is put into the crankcase, please cleanout oil filter and make it in good working condition, then assemble.
- crankcase (with sufficient oil to reach the specified level)

### Oil quantity

#### Periodic oil change

The oil capacity after the engine is disassembled and reassembled.

1.9L

The oil should be put into the engine for after all the oil is drawn out

1.8L

8. Install:

- engine oil filler plug

9. Warm up the engine for a few minutes, then stop the engine.

10. Check:

- engine (for engine oil leaks)

## MAINTENANCE AND ADJUSTMENT OF THE 750UTV

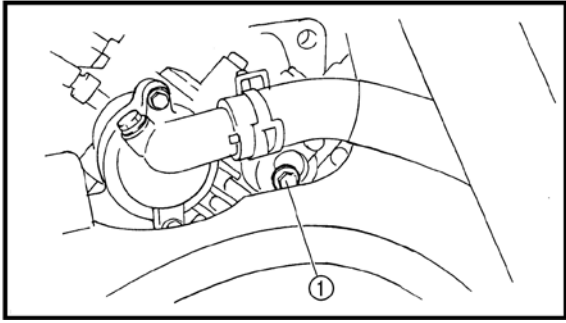

- oil level Refer to “THE ENGINE “ in chapter 4 .
11. Check:
- engine oil pressure
- a. Slightly loosen the oil gallery bolt ①.
  - b. Start the engine and keep it idling until engine oil starts to seep from the oil gallery bolt. If no engine oil comes out after one minute, turn the engine off so that it will not seize.
  - c. Check the engine oil passages, the oil filter cartridge and the oil pump for damage or leakage. Refer to “THE ENGINE” in chapter 4.
  - d. Start the engine after solving the problem(s) and check the engine oil pressure again.
  - e. Tighten the oil gallery bolt to specification.

### Oil gallery bolt

**7 Nm (0.7 m · kg, 5.1 ft · lb)**

12. Install:

- console
- seat

Refer to “SEATS” in chapter 5.



## 750UTV ENGINE

---

### ENGINE

#### ENGINE NOTE

1. Make sure the components, oil, adhesive, sealant are from the company or recommended.
2. Original removal oil seal, gasket, O-ring, piston ring can not be re-assembled again, make sure all these parts are new.
3. Pay attention to keep dismantled parts orderly, make sure their original positions for reassembling.
4. Prevent dismantled parts damaged, clean before measure and assembly, remove the oil with compressed air. Paint the rotating and sliding parts with specified oil, paint or inject designated location with recommended grease.
5. Bolts and nuts tightening order: pre-fixed bolts, and then tighten them from the large diameter to small diameter, from inside to outside by diagonal points 2 or 3 times to the specified torque. Opposite order is for removing bolts and nuts.
6. Make sure sealing bolt (with the sealant) must be replaced
7. Make sure to use new bearing when remove assembly set up by pressure.
8. Determined axial and radial clearance of inner and outer bearing ring by touch, new bear should be replaced if the clearance is too large or non-rotating flexible.
9. Bearing assembly directions: bearing logo should be visible assemblies; confirm bearing outer ring rotate and move reliably and flexibly when assemble bearing by pressure.
10. Oil seal assembly: pay attention to seal side is in the side of oil, logo side outwards, seal side be painted with grease, and make sure seal side without scratch and oil seal be vertical.
11. Before assembly, sealing material attached to all engine covers and crank case combination surface should be cleaned.
12. Before assembly engine, be familiar with engine lubrication circuit, clean and blow oil circuit.

## 750UTV ENGINE

### ENGINE REMOVAL

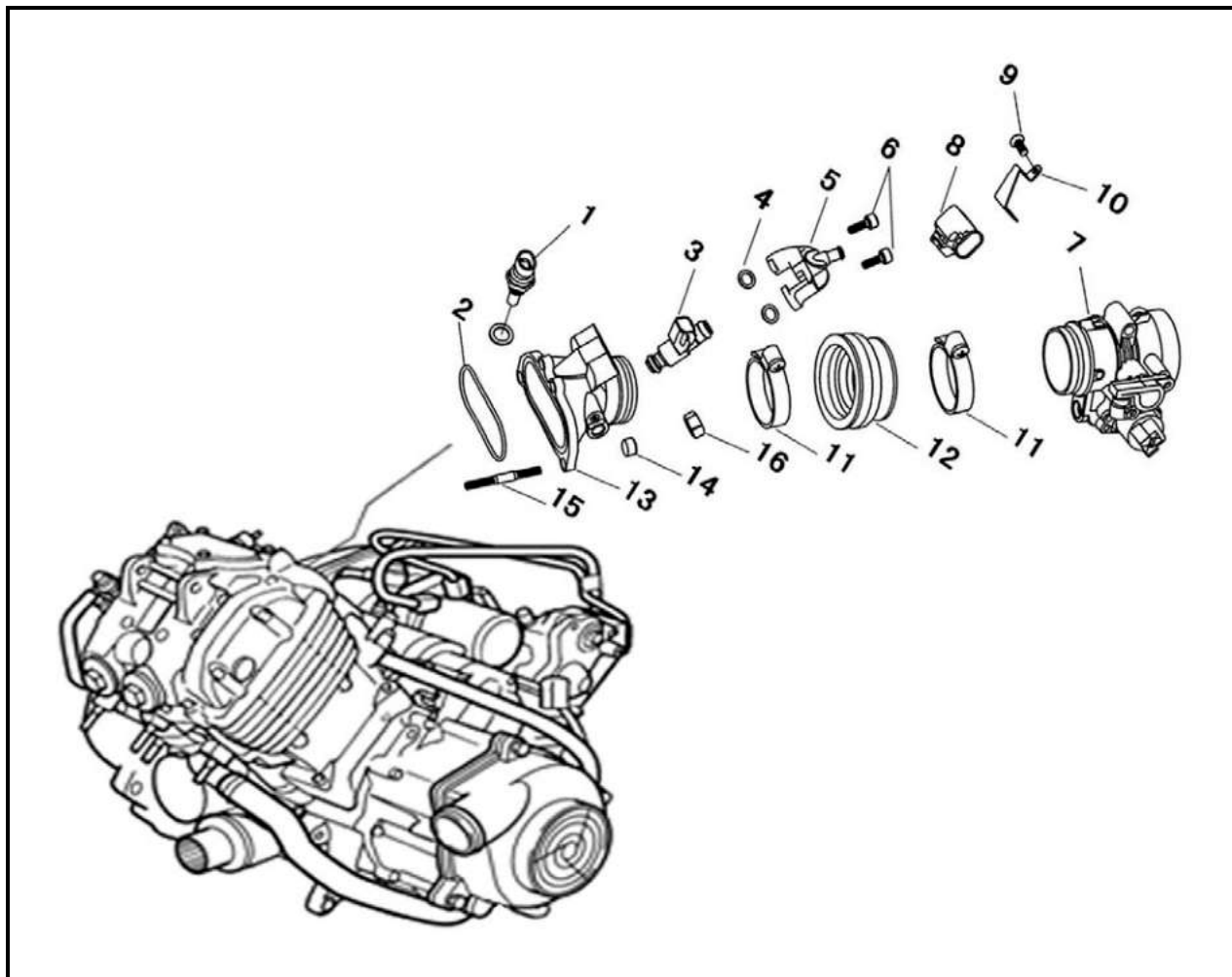

No.	Part Name	Qty	Remarks
	<b>Removing Throttle and intake manifold.</b>		Remove the parts in the order listed.
1	Water temperature sensor	1	
2	O-ring	1	
3	Fuel injection	1	
4	Washer $\phi 6 \times 2$	2	
5	Seat fuel injection	1	
6	Bolt M6 $\times$ 20	2	
7	Ducting dampers	1	
8	Inlet Temperature/pressure sensor	1	
9	Bolt M4 $\times$ 8	1	
10	Pressure plate tmap	1	
11	Clip 50-70	2	
12	Inlet joint head	1	

## 750UTV ENGINE

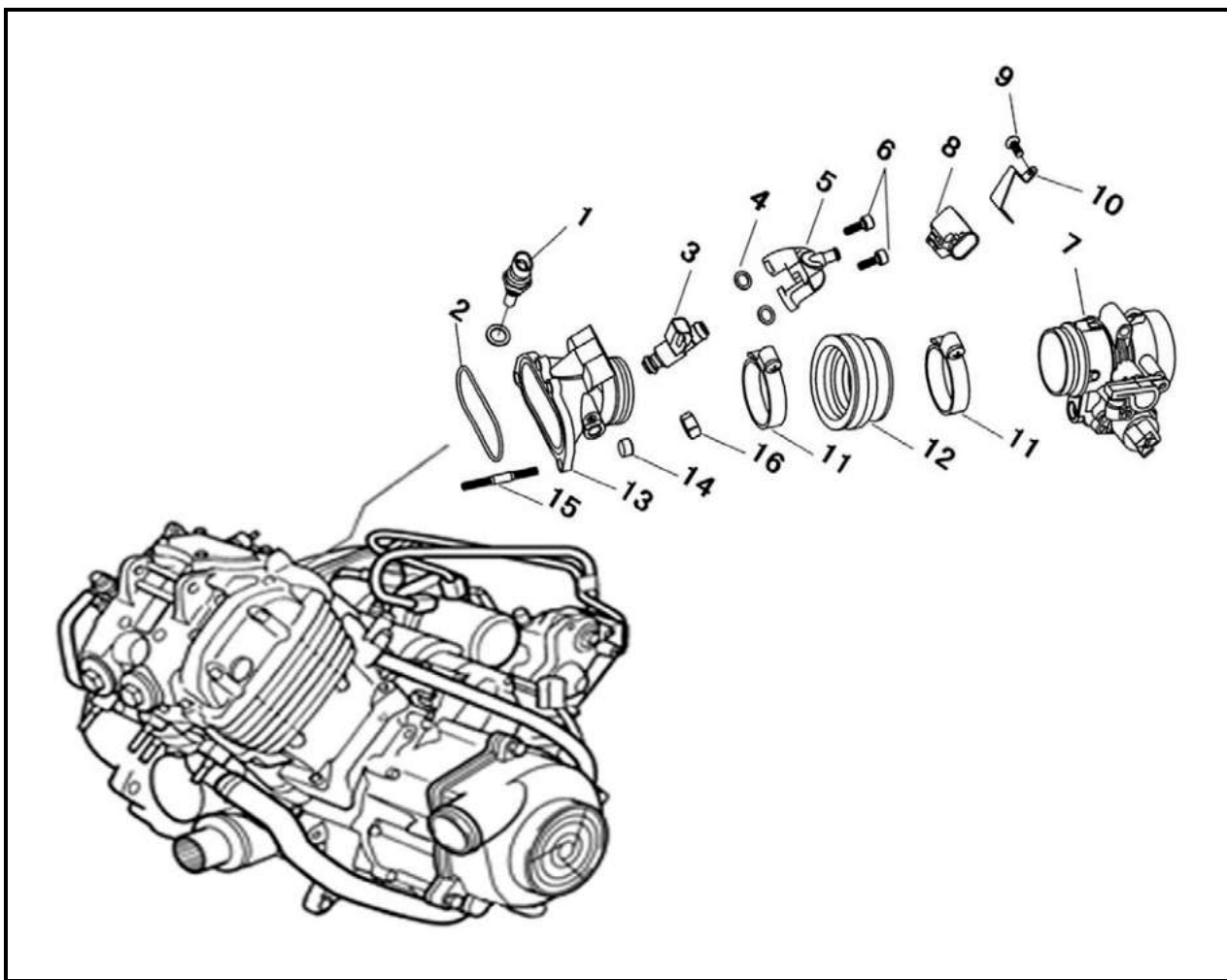

No.	Part Name	Qty	Remarks
13	Inlet pipe	1	For installation, reverse the removal procedure.
14	Bush inlet pipe	4	
15	Bolt stud	4	
16	Nut M6	4	

## 750UTV ENGINE

---

### 1、 NOTE

- Removing the drain plug

**NOTE:**

---

**Before remove drain plug, please prepare vessel for containing oil and cotton yarn.**

---

### 2、 INSTALL

- Install intake manifold
- Install intake manifold bolt
- Install throttle joint
- Install throttle

**NOTE:**

---

**When installed, don't make an object from the intake fell into the cabinet.**

---

# 750UTV ENGINE

## CYLINDER HEAD

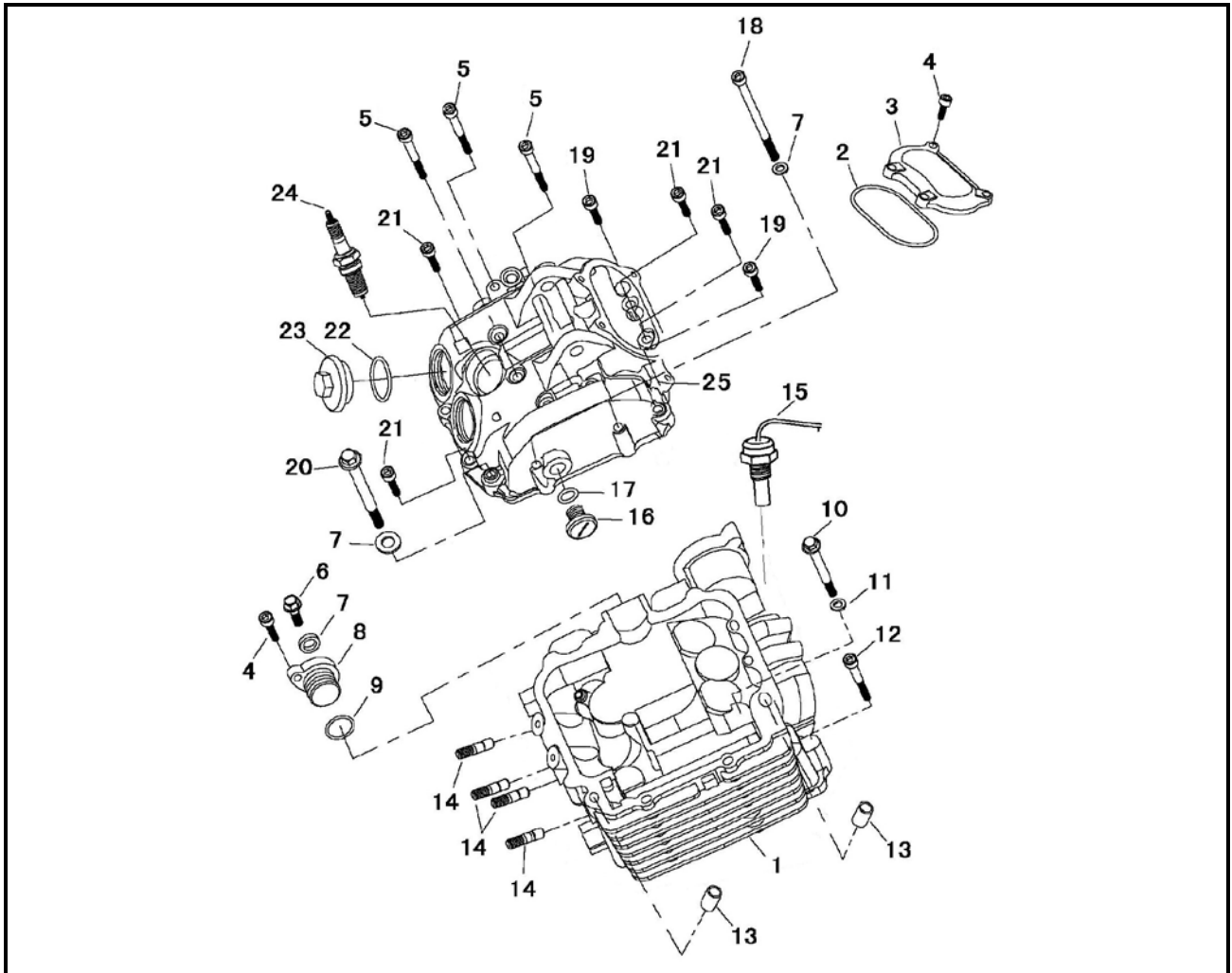

No.	Part Name	Qty	Remarks
	<b>Removing the cylinder head</b>		Remove the parts in the order listed.
1	Cylinder head comp	1	
2	O-Ring 71.5×3	1	
3	Inlet value cover	1	
4	Cylinder screw m6×20,Inner	5	
5	Cylinder screw m6×55,Inner	7	
6	Flange bolt M6×12	1	
7	Aluminum washer $\phi 6 \times \phi 12 \times 1.5$	11	
8	Camshaft end cover	1	
9	O-ring 18.7×2.45	1	
10	Bolt M9×109	4	
11	Washer $\phi 10 \times \phi 19 \times 2$	4	

## 750UTV ENGINE

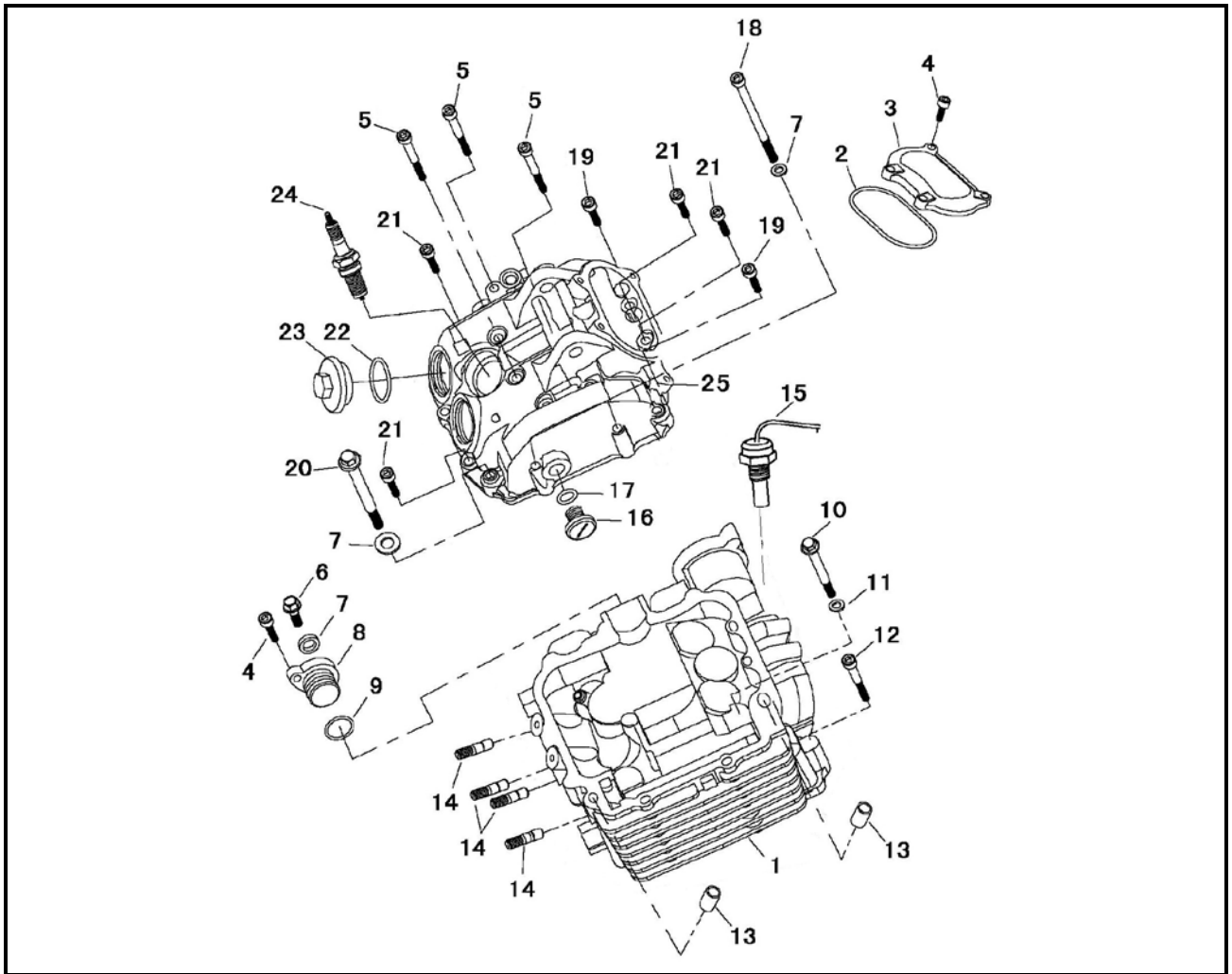

No.	Part Name	Qty	Remarks
12	Dowel pin $\phi$ 10×16	2	
13	Stud bolt M8×45	4	
14	Water temperature alarm switch	1	
15	Hand hole cover	1	
16	O-Ring 13.4×2.35	1	
17	Cylinder screw M6×130,Inner	2	
18	Cylinder screw M6×40,Inner	2	
19	Cylinder screw M6×115,Inner	1	
20	Cylinder screw M6×25,Inner	5	
21	O-ring 32.7×3.1	2	
22	Dowel pin $\phi$ 10×16	2	
23	Outlet valve Cover	2	
			For installation, reverse the removal procedure.

# 750UTV ENGINE

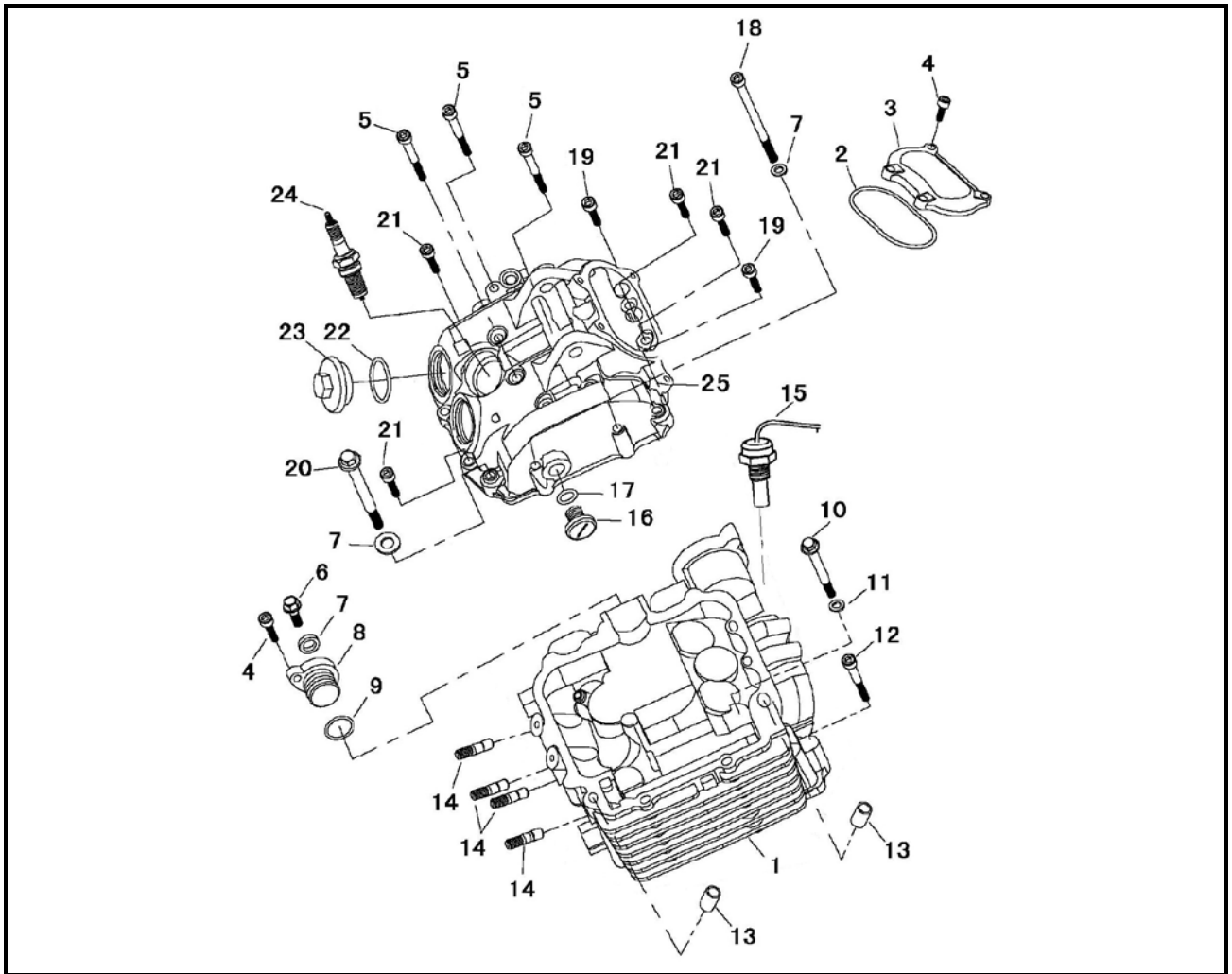

No.	Part Name	Qty	Remarks
24	Spark plug(NGK DCPR7E)	1	For installation, reverse the removal procedure.
25	Cylinder head cover	1	

## 1、CHECK

### 1). Checking the valve clearance

- Valve clearance

Refer to “ADJUSTING THE VALVE CLEARANCE” in chapter 3.

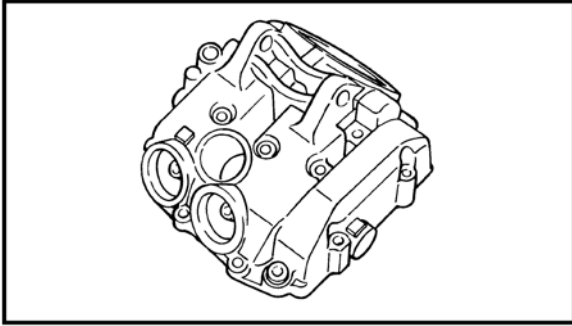

### 2). Checking the cylinder head cover

- cylinder head cover

Cracks/damage → Replace the cylinder head cover and cylinder head as a set.

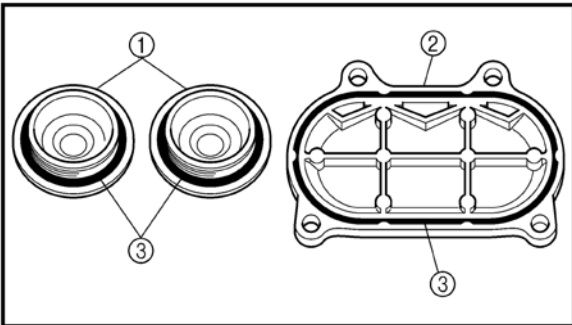

### 3). Checking the tappet covers

- tappet cover (exhaust) ①

- tappet cover (intake) ②

Cracks/damage → Replace.

- O-rings ③

### **NOTE:**

**When installing, new replacement washer and apply wheel bearing grease LS.**

---

### 4). Removing the screwdriver and slowly release the timing chain tensioner rod.

### **NOTE:**

**Make sure that the timing chain tensioner rod comes out of the timing chain tensioner housing smoothly. If there is rough movement, replace the timing chain tensioner.**

---

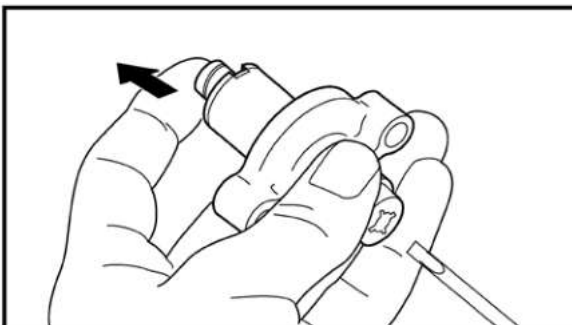



## 750UTV ENGINE

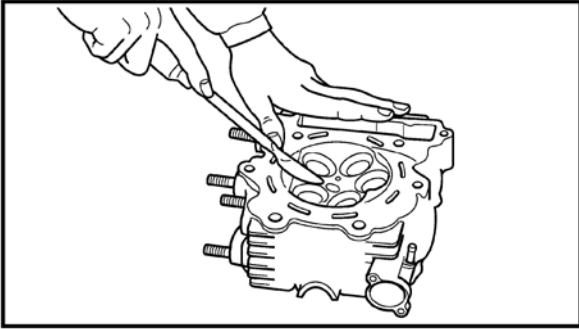

### 5). Checking the cylinder head

#### (1). Eliminate:

- carbon deposits (from the combustion chamber)

Use a rounded scraper.

#### **NOTE:**

**Do not use a sharp instrument to avoid damaging or scratching:**

- spark plug threads
- valve seats

#### (2). Check:

- cylinder head

Scratches/damage → Replace the cylinder head cover and cylinder head as a set.

- cylinder head water jacket

Mineral deposits/rust → Eliminate.

## 2. INSTALL

### 1). Installing the cylinder head cover

- cylinder head cover
- washers ①
- bolts ② (Allen wrench M5 , 8-12 Nm)

#### **NOTE:**

**Tighten the cylinder head cover bolts in stages, using a crisscross pattern.**

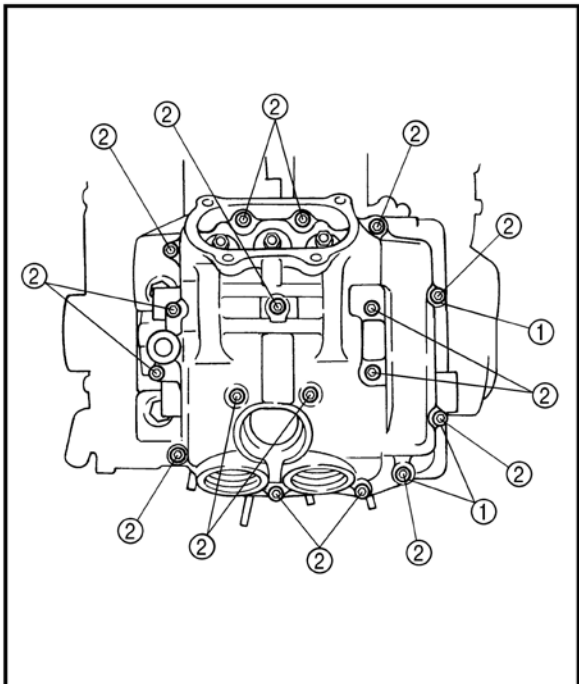

## 750UTV ENGINE

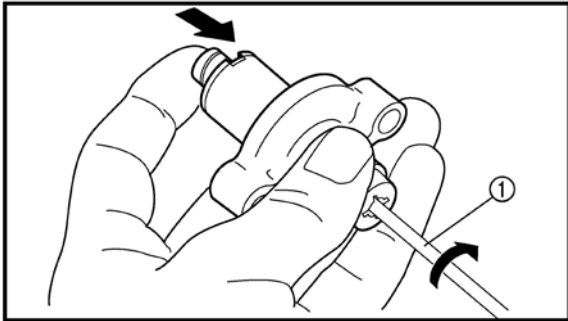
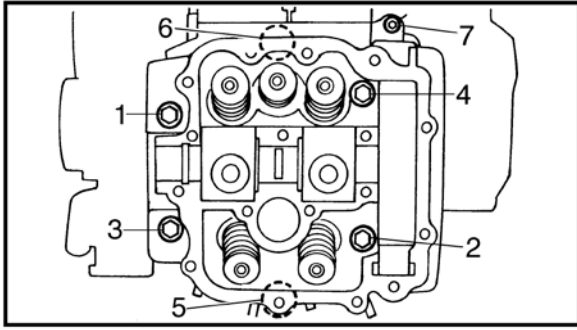

### 2). Installing the cylinder head

- cylinder head gasket
- cylinder head
- bolts (M9: 1 ~ 6, 38Nm)
- bolts (M6: 7, 10Nm)

#### **NOTE:**

- **Tighten the bolts in the proper sequence.**
- **Follow the numerical order shown in the illustration. Tighten the bolts in two stages.**

- timing chain guide (exhaust side)
- timing chain tensioner

- a. Lightly press the timing chain tensioner rod into the timing chain tensioner housing by hand.
- b. While pressing the timing chain tensioner rod, wind it clockwise with a thin screwdriver (1) until it stops.
- c. With the screwdriver still inserted into the timing chain tensioner, install the timing chain tensioner and gasket onto the cylinder block. Then, tighten the timing chain tensioner bolts to the specified torque.

#### **WARNING:**

**Always use a new gasket.**

#### **NOTE:**

The "UP" mark on the timing chain tensioner should face up.

**Timing chain tensioner bolt (10 Nm)**

- d. Remove the screwdriver, make sure that the timing chain tensioner rod releases, and tighten the cap bolt to the specified torque.

**Timing chain tensioner cap bolt (7 Nm)**

# 750UTV ENGINE

## VALVE SWING ARM COMP&VALVE

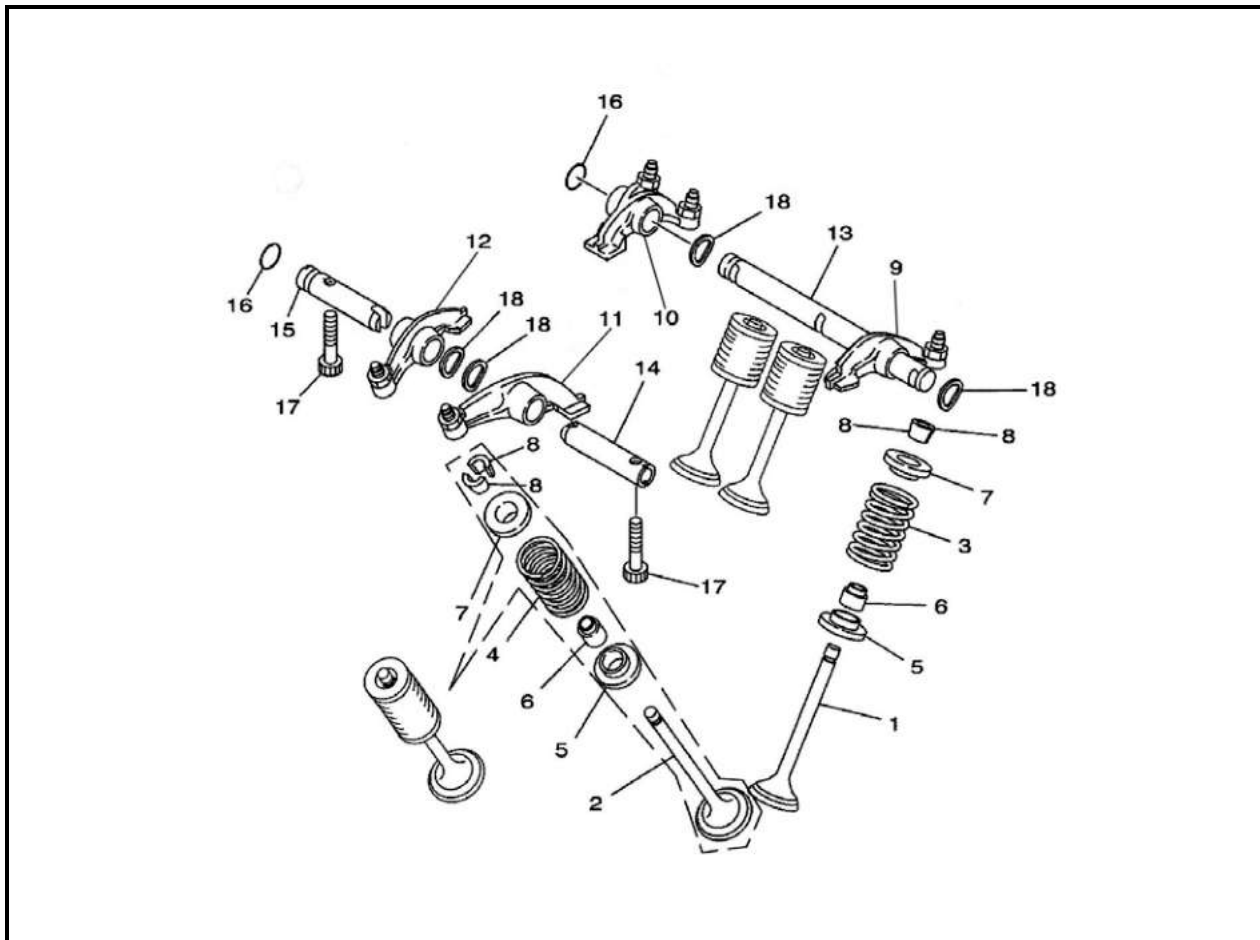

No.	Part Name	Qty	Remarks
	<b>Removing the valve swing arm</b>		Remove the parts in the order listed.
1	Inlet valve	3	
2	Outlet valve	2	
3	Spring inlet valve	3	
4	Spring outlet valve	2	
5	Spring seat valve	5	
6	Fuel shield cover comp	5	
7	Cotter seat- valve	5	
8	Lock clip valve	10	
9	Swing arm comp inlet valve I	1	
10	Swing arm comp inlet valve II	1	
11	Swing arm comp outlet valve II	1	
12	Swing arm comp outlet valve I	1	
13	Rocker arm shaft I	1	
14	Rocker arm shaft III	1	

# 750UTV ENGINE

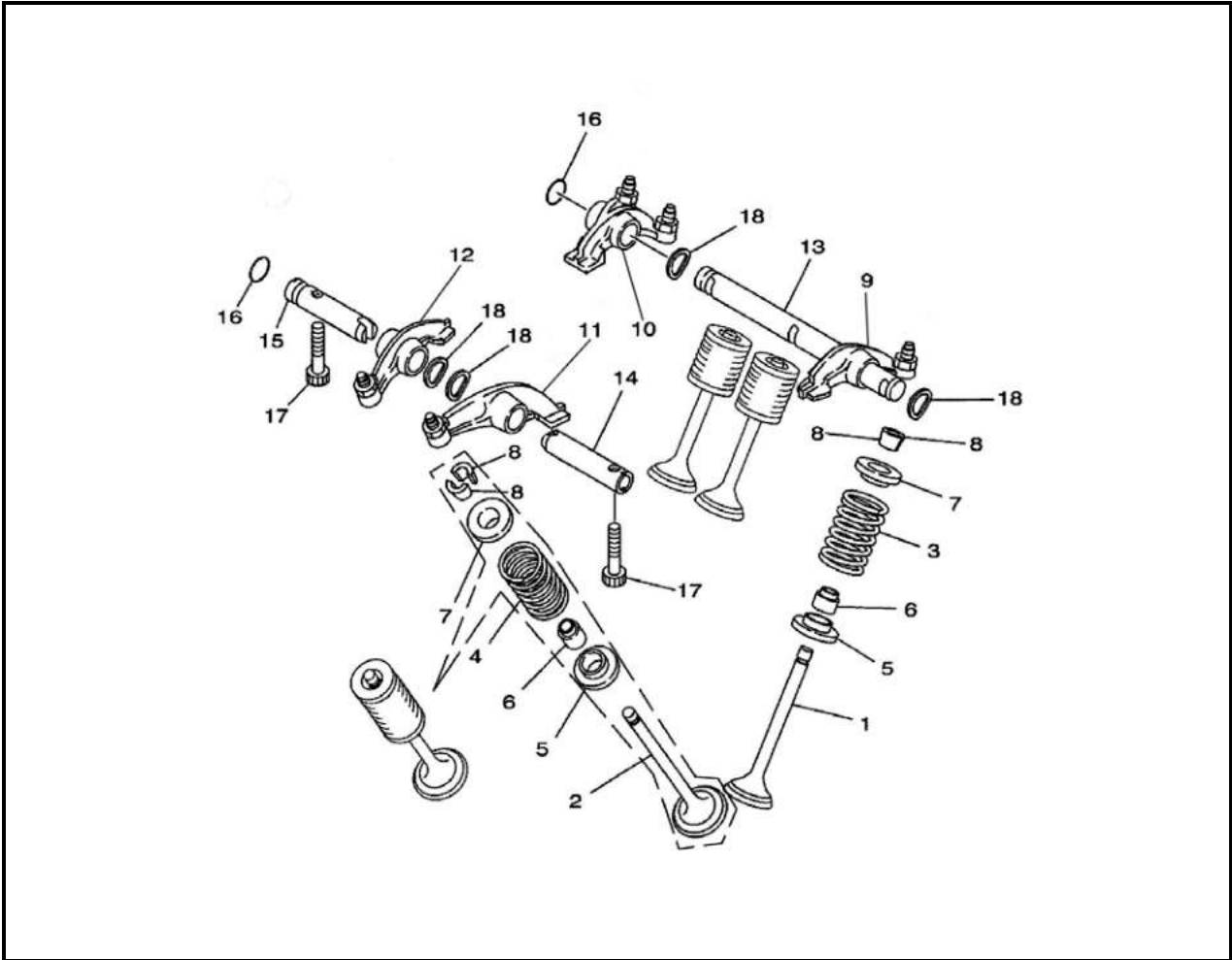

No.	Part Name	Qty	Remarks
15	Rocker arm shaft II	1	
16	O-ring 9×2	2	
17	Inner hexangular screw M6×20	2	
18	Washer φ 12.5× φ 34×0.4	4	
			For installation, reverse the removal procedure.

# 750UTV ENGINE

## CAMSHAFT CHAIN

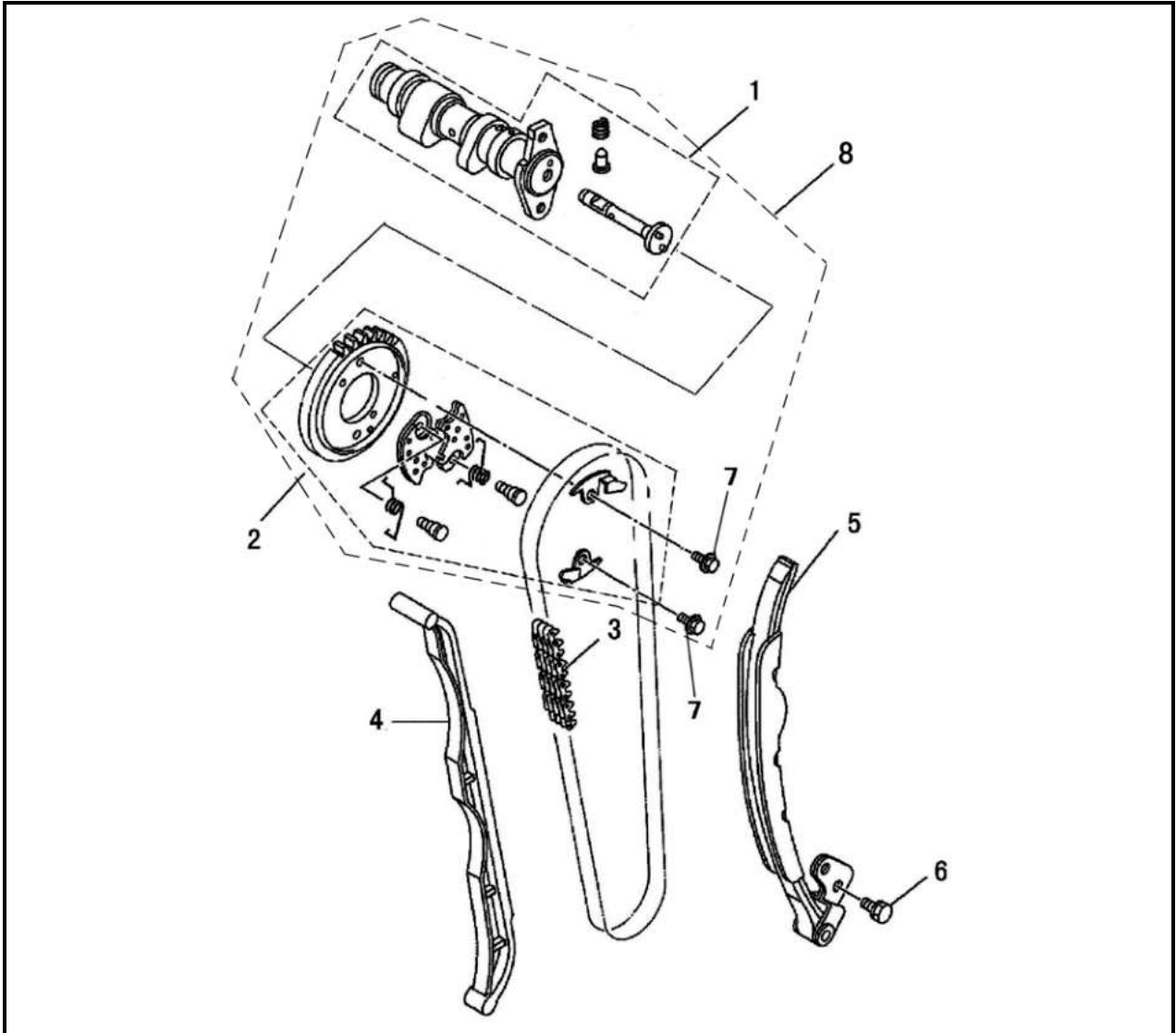

No.	Part Name	Qty	Remarks
1	Cam shaft comp	1	
2	Driven sprocket assy timing	1	
3	China (M7-6.35-126)	1	
4	Guide plate	1	
5	Tension plate comp	1	
6	Bolt M6×16	2	
7	Bolt M7×11	2	
8	Cam shaft assembly	1	
			For installation, reverse the removal procedure.

## 750UTV ENGINE

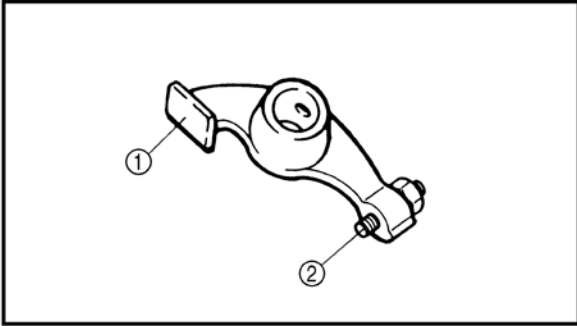

### 1、 CHECK

#### 1). Checking the rocker arms

- rocker arm lobes ①
- valve adjusters ②

Blue discoloration/pitting/scratches → Replace.

- rocker arms
- rocker arm shafts

Damage/wear → Replace.

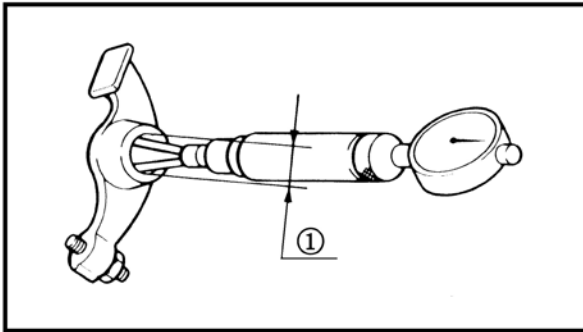

- Check whether the rocker arm is worn out, or damaged and whether the oil hole is blocked.
- If there is a rocker arm to be replaced, check the camshaft prominent position of unfairness.
- Measure the inside diameter of the rocker arm holes ①.

Out of specification → Replace.

**Rocker arm inside diameter repairing limit value**

**Φ12.038mm**

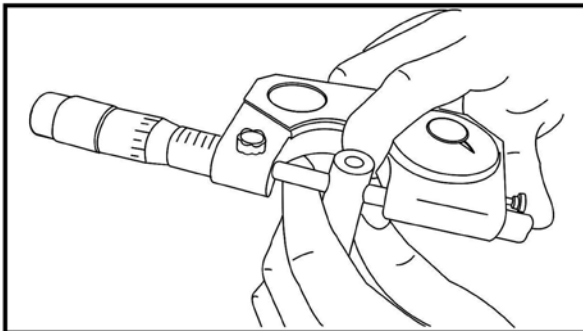

- Check the surface of the rocker arm shafts.  
Worn/pitting/scratches → Replace.
- Measure the external diameter of rocker arm shaft with micrometer.

Out of specification → Replace.

**Rocker arm shaft outside diameter repairing limit value**

**Φ11.96mm**

- Calculate the clearance by subtracting the rocker arm shaft outside diameter from the rocker arm inside diameter.

Out of specification → Replace the defective part(s).

**Rocker arm to shaft clearance repairing limit value**

**0.05mm**

## 750UTV ENGINE

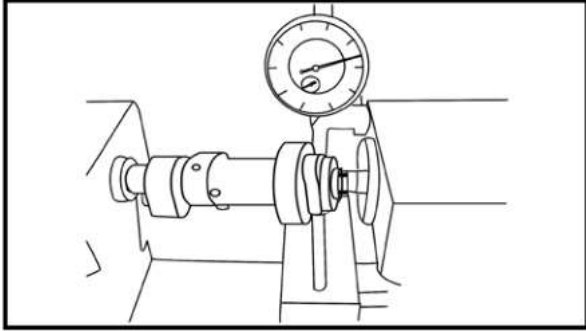

### 2). Checking the camshaft

- cam lobes  
Pitting/scratches/blue discoloration → Replace
- camshaft journal  
Wear/damage → Replace
- Measure the external diameter of camshaft journal with micrometer.  
Out of specification → Replace.
- small holes on camshaft sprocket
- rotor "I" mark  
Out of alignment

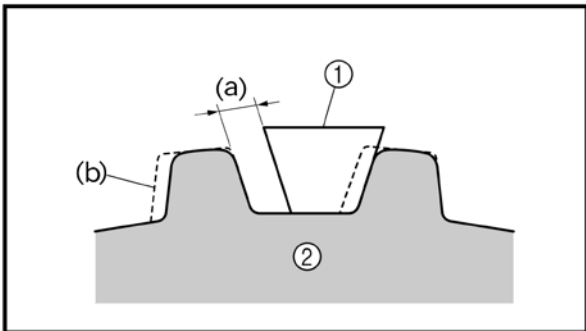

### 3). Checking the camshaft sprocket

- camshaft sprocket  
Wear/damage → Replace the camshaft sprocket and timing chain as a set.

(a) 1/4 of a tooth

(b) Correct

- ① Timing chain
- ② Sprocket

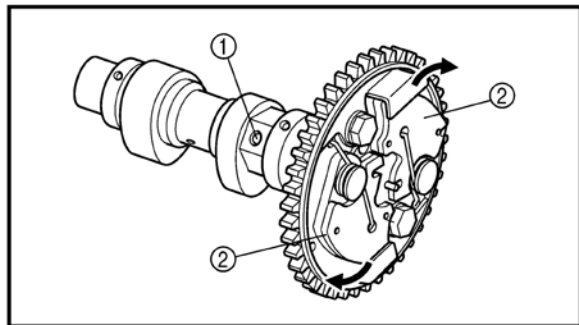

### 4). Checking the decompression system

- decompression system  
Check while the camshaft sprocket is installed on the camshaft.
- a. Check that the decompressor lever pin ① projects from the camshaft.
- b. Check that the decompressor cam smoothly.

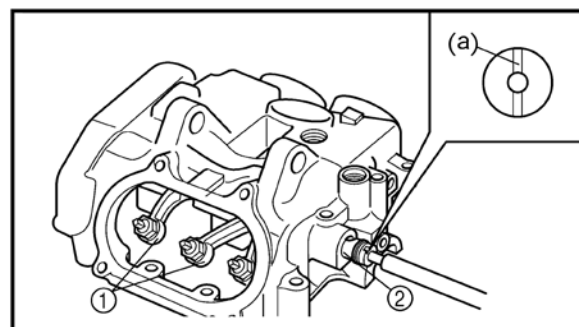

## 2. INSTALL

### 1). Installing the rocker arms

- rocker arms ①
- rocker arm shafts ②

#### **NOTE:**

- The thread hole (a) of the rocker arm shaft must face to the outside.
- After installation, make sure that the thread hole (a) of the rocker arm shaft is positioned correctly, as shown in the illustration.

## 750UTV ENGINE

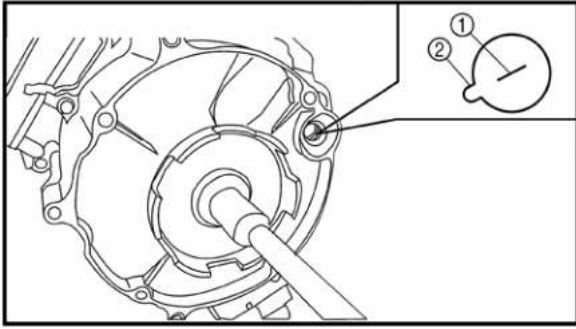

### 2). Installing the camshaft

- camshaft
  - camshaft sprocket
- Turn the crankshaft counterclockwise with a T-sleeve.
  - Align the "I" mark ① on the rotor with the stationary pointer ② on the A.C. magneto cover. When the "I" mark is aligned with the stationary pointer, the piston is at the Top Dead Center (TDC).

#### **CAUTION:**

**Do not turn the crankshaft during the camshaft installation.**

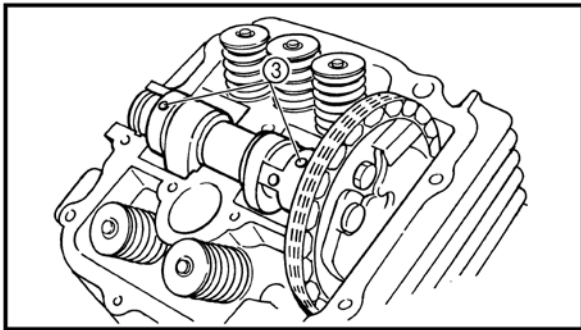

- Temporarily install the camshaft sprocket on the camshaft. (Do not install the bolts.) Then, install the timing chain on the camshaft sprocket.

#### **NOTE:**

**Make sure the small holes ③ on the camshaft face upward.**

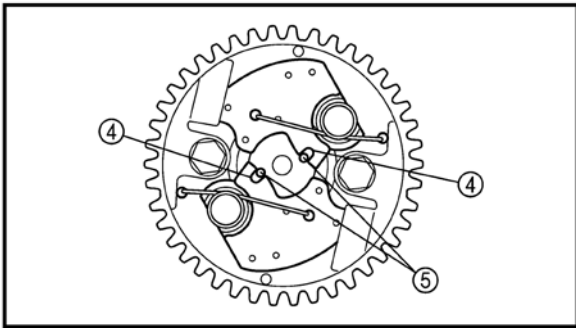

- Align the notches ④ on the decompressor cams with the projections ⑤ on the decompressor spring lever, then install the camshaft sprocket on the camshaft.

#### **NOTE:**

**Check that each part is positioned as shown in the illustration.**

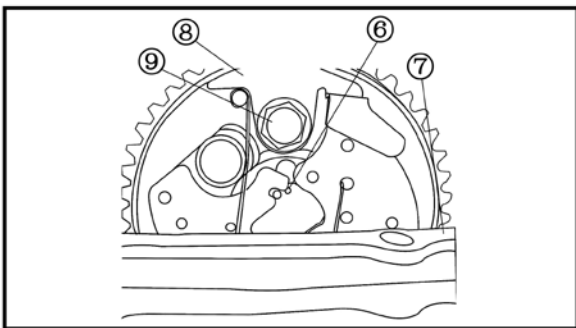

⑥Punch mark on decompressor spring lever

⑦Top front of cylinder head

- Install the decompressor cam guide plates ⑧ and camshaft sprocket bolts ⑨

**Camshaft sprocket bolt(20 Nm)**



## 750UTV ENGINE

---

**NOTE:**

Insert a screwdriver into the timing chain tensioner hole and push the timing chain guide (intake side) inward.

---

f. Remove the retaining wire.

# 750UTV ENGINE

## VALVES AND VALVE SPRINGS

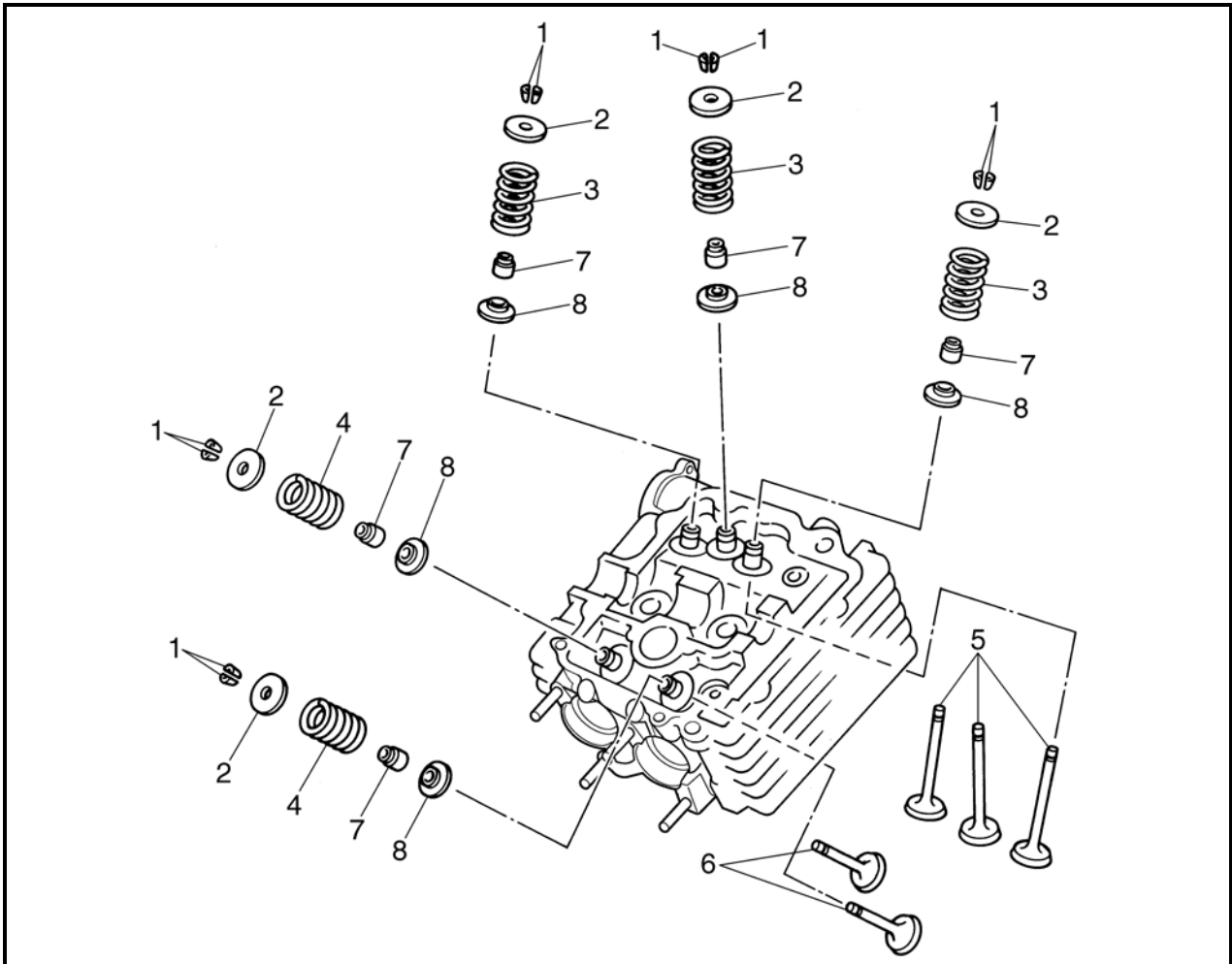

No.	Part Name	Qty	Remarks
	<b>moving the valves and valve springs</b>		Remove the parts in the order listed.
	Cylinder head cover		
1	Valve cotter	10	
2	Valve spring retainer	5	
3	Intake valve spring	3	
4	Exhaust valve spring	2	
5	Intake valve	3	
6	Exhaust valve	2	
7	Valve stem seal	5	
8	Valve spring seat	5	
			For installation, reverse the removal procedure.

## 750UTV ENGINE

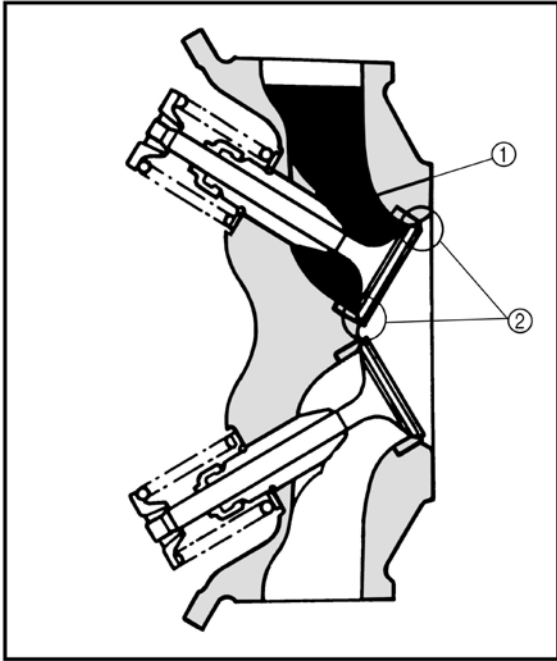

### 1、 CHECK

- valve sealing

Leakage at the valve seat → Check the valve face, valve seat and valve seat width.

- a. Pour a clean solvent ① into the intake and exhaust ports.
- b. Check that the valve seals properly. There should be no leakage at the valve seat ②.

- valve face

Pitting/wear → Grind the face.

- valve stem end

Mushroom shape or diameter larger than the body of the stem → Replace.

- valve seats

Pitting/wear → Reface the valve seat.

### 2、 MEASURE

- 1). Measure:

- The valves surface width

**Repairing limit value**

**2.0mm**

- stem-to-guide clearance

**Stem-to-guide clearance = valve guide  
inside diameter – valve stem diameter**

#### **1NOTE:**

If the mating surface is coarse, corrode or cannot contact with valve seat normally, replace it.

**Stem-to-guide clearance**

**repairing limit value**

**Intake:0.12mm    Exhaust:0.14mm**

- margin thickness (a)

Out of specification → Replace.

**Margin thickness**

**Intake:0.85 ~ 1.15 mm**

**Exhaust:0.85 ~ 1.15 mm**

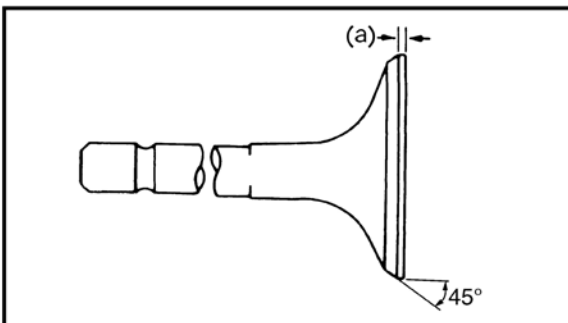

## 750UTV ENGINE

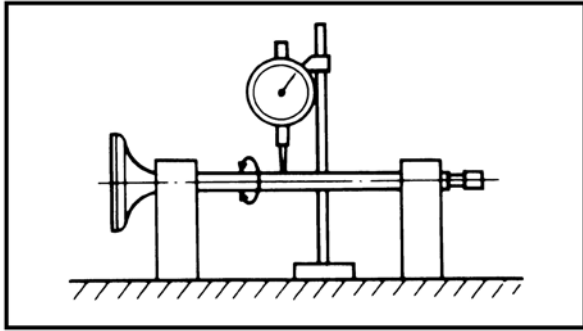

- valve stem runout  
Out of specification → Replace.

**Runout limit 0.01 mm**

**NOTE:**

- When installing a new valve always replace the guide.
- If the valve is removed or replaced always replace the oil seal.

- The valve seat surface width  
Out of specification → Reface the valve seat.

**Repairing limit value  
2.0mm**

- Install the valve into the cylinder head.
- Press the valve through the valve guide and onto the valve seat to make a clear pattern.
- Measure the valve seat width. Where the valve seat and valve face made contact, blueing will have been removed.

- Valve spring free length  
Out of specification → Replace.

**Valve spring free length**  
Intake:32.5mm    Exhaust:36.2mm  
**Valve spring squareness**  
Intake:0.10mm    Exhaust:0.10mm

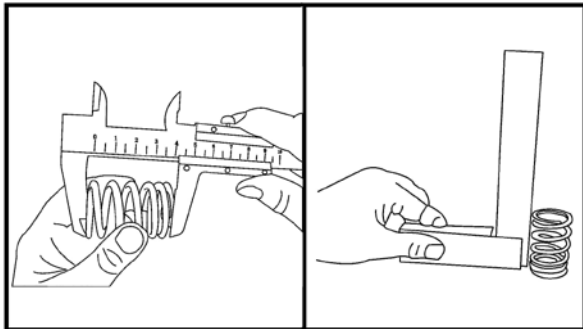

- compressed spring force(a)  
Out of specification → Replace.

(b) Installed length

**Compressed spring force**  
Intake: 100.0 ~ 115.7 N at 27.5 mm  
Exhaust: 120.6 ~ 138.3 N at 31.0 mm

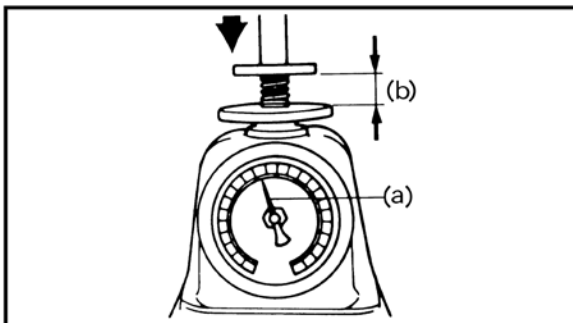

- Remove:
  - valve guide

## 750UTV ENGINE

---

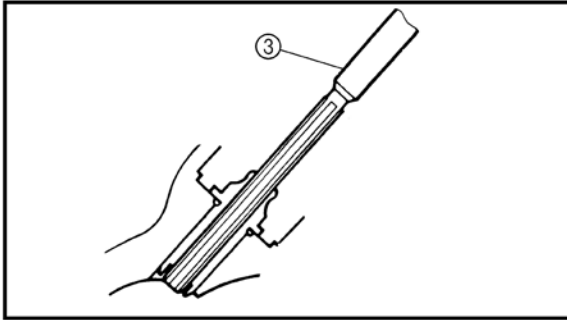
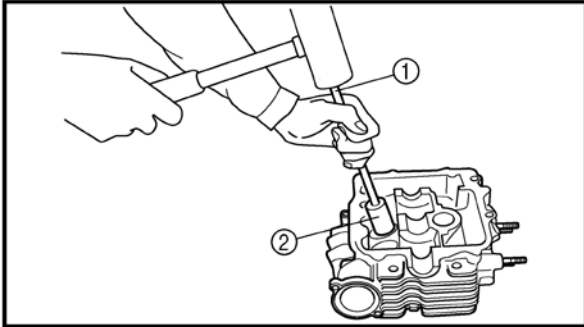

---

**NOTE:**

To ease guide removal, installation and to maintain correct fit, heat the cylinder head to 100 °C (212 °F) in an oven.

---

- Install the new valve guide using a valve guide remover ① and valve guide installer ②.
- After installing the valve guide, bore the valve guide using a valve guide reamer ③ to obtain proper stem-to-guide clearance.

---

**NOTE:**

After replacing the valve guide reface the valve seat.

---

- If the valve seat is too wide or narrow or cracked, grind it to ensure impermeability.

3). Lap:

- valve face
- valve seat

---

**NOTE:**

After refacing the valve seat or replacing the valve and valve guide, the valve seat and valve face should be lapped.

---

- If the pipe will be replaced, grind the valve seat again.

---

**CAUTION:**

Do not let the compound enter the gap between the valve stem and the guide.

---

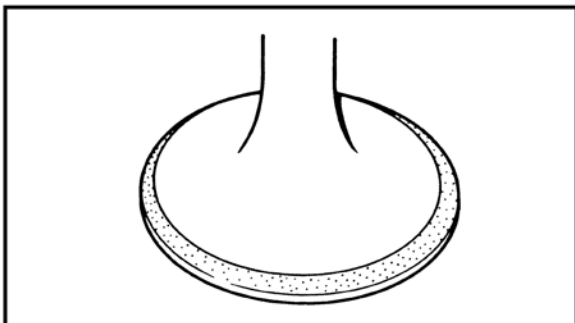

- Install the valve into the cylinder head.
- Turn the valve until the valve face and valve seat are evenly polished, then clean off all of the compound.

## 750UTV ENGINE

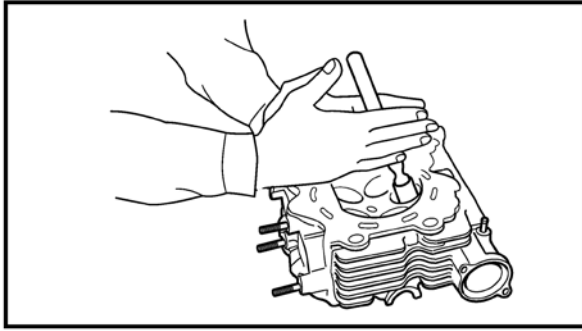

---

**NOTE:**

For best lapping results, lightly tap the valve seat while rotating the valve back and forth between your hands.

---

d. Apply a fine lapping compound to the valve face and repeat the above steps.

---

**NOTE:**

After every lapping operation be sure to clean off all of the compound from the valve face and valve seat.

---

e. Install the valve into the cylinder head.

g. Press the valve through the valve guide and onto the valve seat to make a clear pattern.

h. Measure the valve seat width again. If the valve seat width is out of specification, reface and relapse the valve seat.

### 3. INSTALL:

1). Apply:

- molybdenum disulfide oil  
(onto the valve stem and valve stem seal)

2). Install:

- valve spring seats
- valve stem seals
- valves
- valve springs
- valve spring retainers

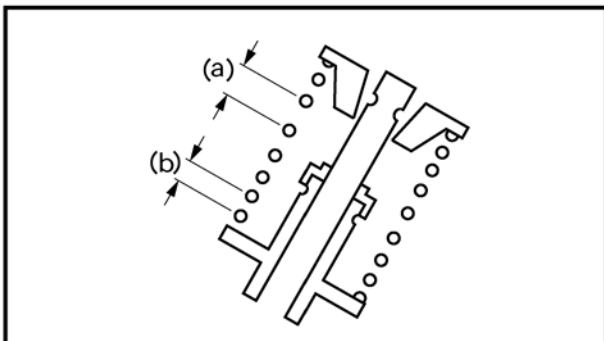

---

**1NOTE:**

Install the valve springs with the larger pitch (a) facing upwards.

---

(b) Smaller pitch

- valve cotters

---

**NOTE:**

Install the valve cotters while compressing the valve spring with the valve spring compressor ① and valve spring compressor attachment ②.

---

## 750UTV ENGINE

---

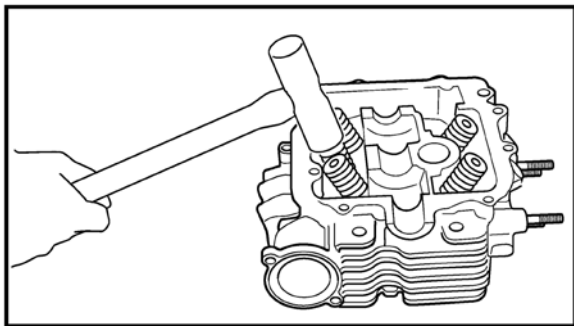

To secure the valve cotteners onto the valve stem, lightly tap the valve tip with a piece of wood.

**CAUTION:** \_\_\_\_\_  
Hitting the valve tip with excessive force could damage the valve.  
\_\_\_\_\_

# 750UTV ENGINE

## CYLINDER AND PISTON

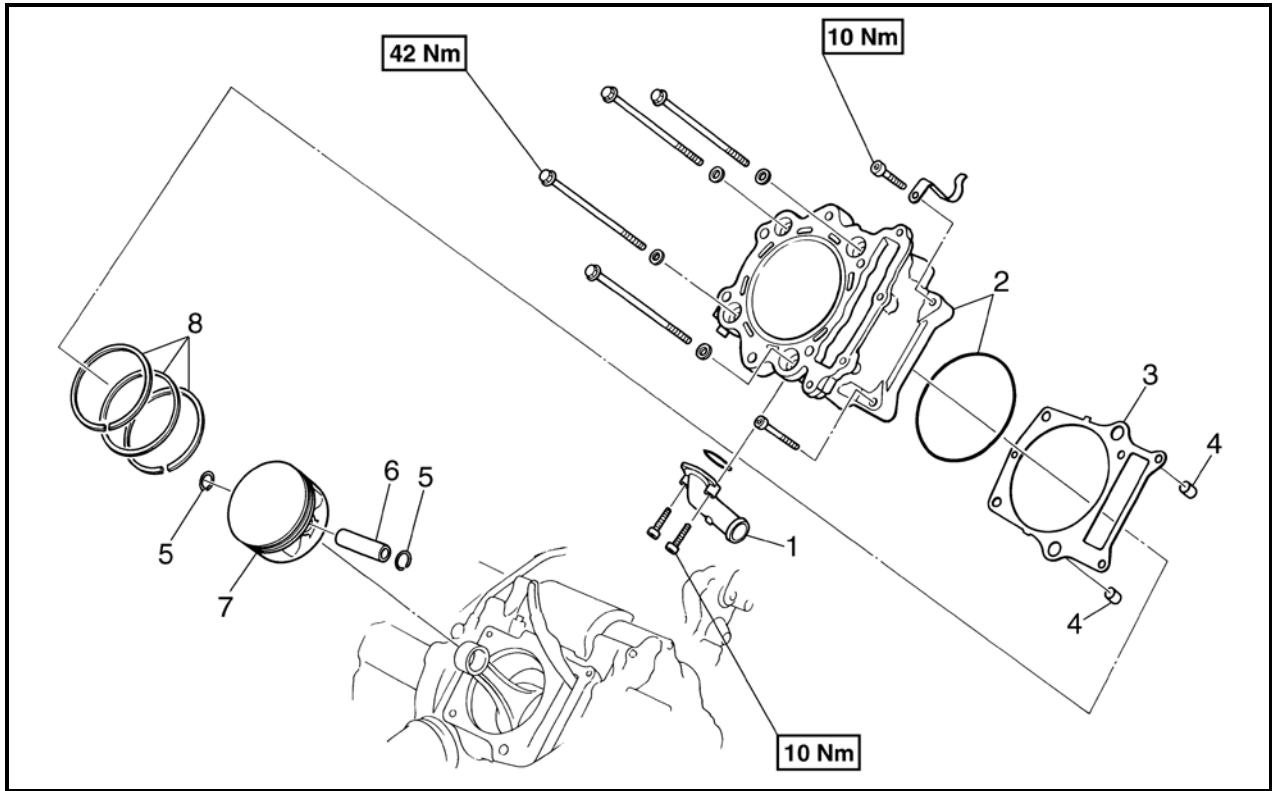

No.	Part Name	Qty	Remarks
	<b>Removing the cylinder and piston</b>		Remove the parts in the order listed.
	Water pump outlet hose		
	Cylinder head		
1	Coolant inlet joint	1	
2	Cylinder/O-ring	1/1	
3	Cylinder gasket	1	
4	Dowel pin	2	
5	Piston pin clip	2	
6	Piston pin	1	
7	Piston	1	
8	Piston ring set	1	
			For installation, reverse the removal procedure.



# 750UTV ENGINE

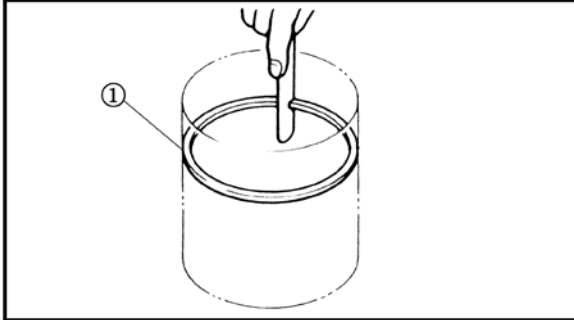

## 1、CHECK

- 1).Checking the cylinder and piston
  - cylinder and piston walls Vertical scratches → Rebore or replace the cylinder and the piston.
- 2).Checking the piston rings
  - piston ring  
(Insert in cylinder piston ring will be ① ,and measure the end gap.)

### **NOTE:**

**Check whether the piston and the piston groove is cracked and abraded.**

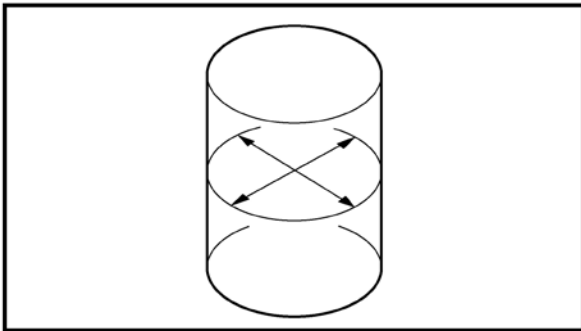

- 3).Checking the piston pin
  - piston pin

Blue discoloration/grooves → Replace, then check the lubrication system.

## 2、MEASURE

- At the top, the middle and the bottom of the piston stroke.

### **NOTE:**

**Measure the bore diameter at directions of right-angle intersection.**

### Repairing limit value

**Out of roundness:0.005mm**

**Taper:0.005mm**

- The external diameter 10mm above the bottom of the piston skirt.

### **NOTE:**

**Repair limit on the clearance between the piston and cylinder.**

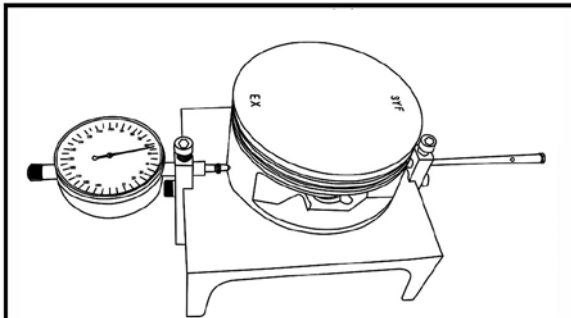

### Repairing limit value

**0.1mm**

## 750UTV ENGINE

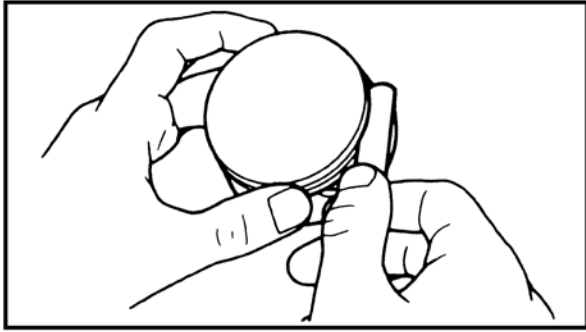

- ring end gap

Out of specification → Replace.

### Repairing limit value

**Top ring/2nd ring:0.5mm**

- ring side clearance

Use a thickness gauge.

Out of specification → Replace the piston and rings as a set.

### NOTE:

**Clean carbon from the piston ring grooves and rings before measuring the side clearance.**

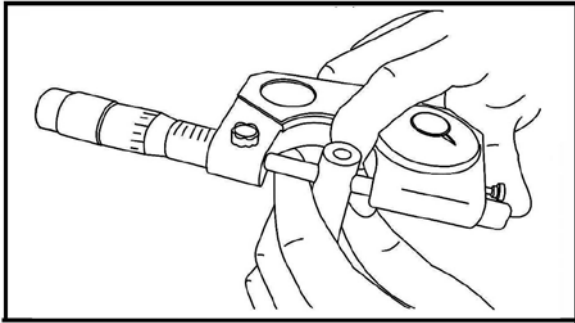

	Side clearance	
	Standard	Limit
<b>Top ring</b>	<b>0.04~0.08mm</b>	<b>0.13mm</b>
<b>2nd ring</b>	<b>0.03~0.07mm</b>	<b>0.13mm</b>

- piston pin-to-piston clearance.

a. Measure the piston pin outside diameter.

### Repairing limit value

**0.02mm**

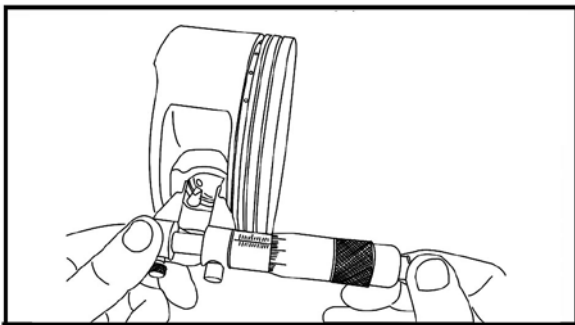

b. Measure the piston pin bore inside diameter.

### Repairing limit value

**0.02mm**

c. Calculate the piston pin-to-piston clearance with the following formula.

Piston pin-to-piston clearance = Piston pin bore inside diameter – Piston pin outside diameter

d. If out of specification, replace the piston.

## 750UTV ENGINE

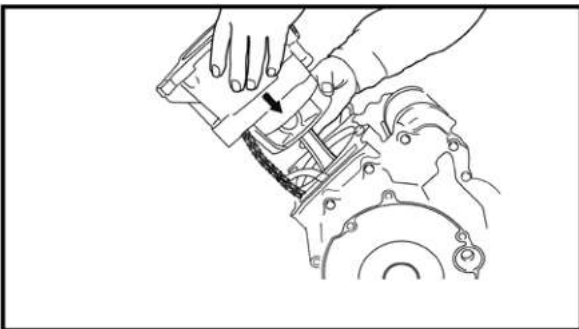
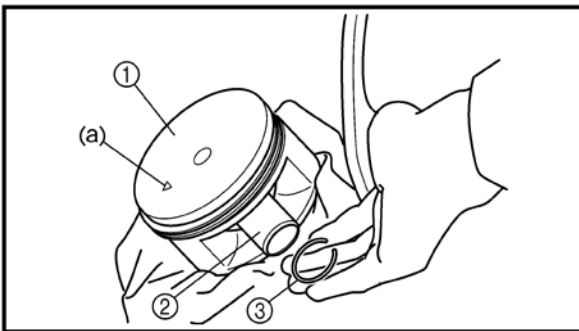
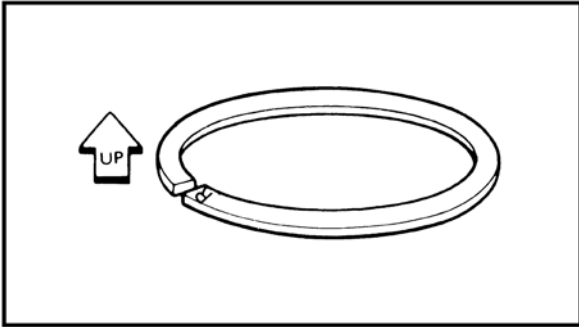

### 3. INSTALL:

#### 1). Installing the piston

- piston rings  
(onto the piston)

#### **NOTE:**

- Be sure to install the piston rings so that the manufacturer's marks or numbers are located on the upper side of the rings.
- Lubricate the piston and piston rings liberally with engine oil.

- piston ①
- piston pin ②
- piston pin clips (new replacement)

#### **NOTE:**

- Apply engine oil onto the piston pin, piston rings and piston.
- Be sure that the arrow mark a on the piston points to the exhaust side of the engine.
- Before installing the piston pin clip, cover the crankcase with a clean rag to prevent the piston pin clip from falling into the crankcase.

#### 2). Installing the cylinder

- cylinder
- O-ring
- bolts (M10,42Nm)
- bolts (M6,10Nm)

#### **NOTE:**

Install the cylinder with one hand while compressing the piston rings with the other hand.

#### **CAUTION:**

- Be careful not to damage the timing chain guide during installation.
- Pass the timing chain through the timing chain cavity.

# 750UTV ENGINE

## ENGINE COOLING FAN AND A.C. MAGNETO

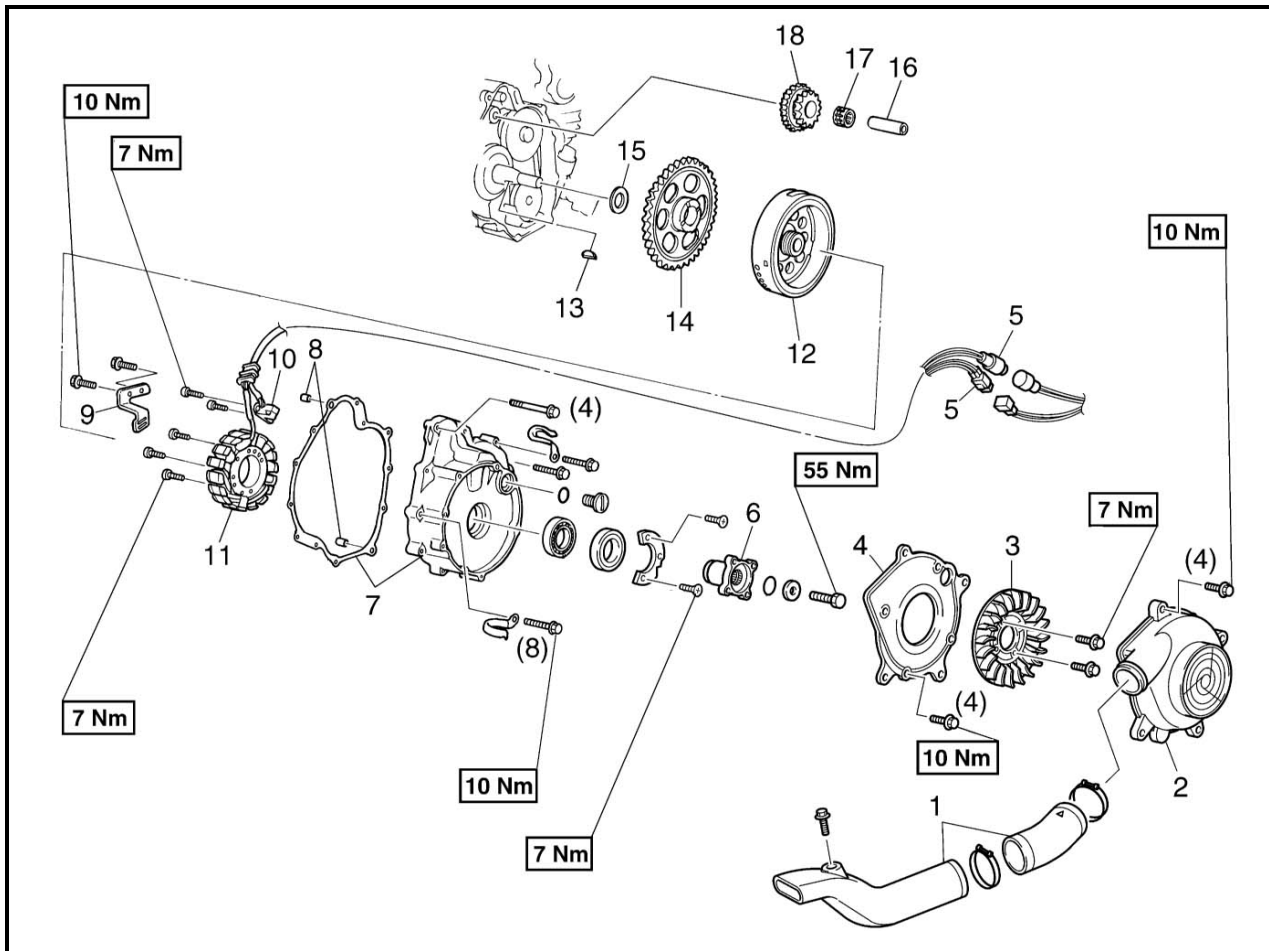

No.	Part Name	Qty	Remarks
	<b>Removing the engine cooling fan and A.C. magneto</b>		Remove the parts in the order listed.
	Drive belt cover		
	Engine oil		
	Coolant		
	Water pump assembly		
1	Engine cooling fan air duct assembly	1	
2	Air shroud 1	1	
3	Engine cooling fan	1	
4	Air shroud 2	1	
5	A.C. magneto coupler	2	
6	Engine cooling fan pulley base	1	
7	A.C. magneto cover/gasket	1/1	
8	Dowel pin	2	
9	Stator lead holder	1	

# 750UTV ENGINE

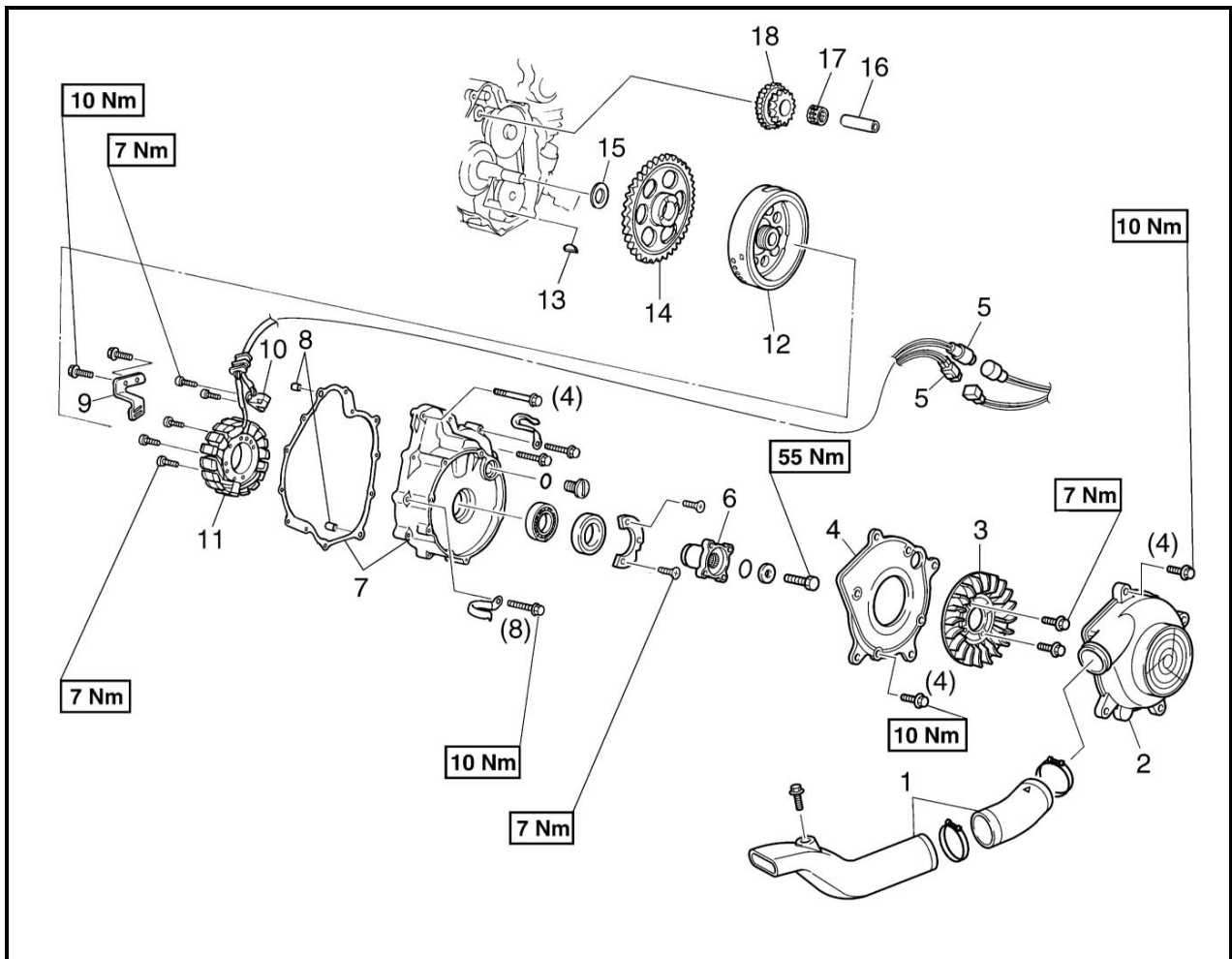

No.	Part Name	Qty	Remarks
10	Pickup coil	1	For installation, reverse the removal procedure.
11	Stator assembly	1	
12	A.C. magneto rotor	1	
13	Woodruff key	1	
14	Starter wheel gear	1	
15	Washer	1	
16	Starter idle gear shaft	1	
17	Bearing	1	
18	Starter idle gear	1	

## 750UTV ENGINE

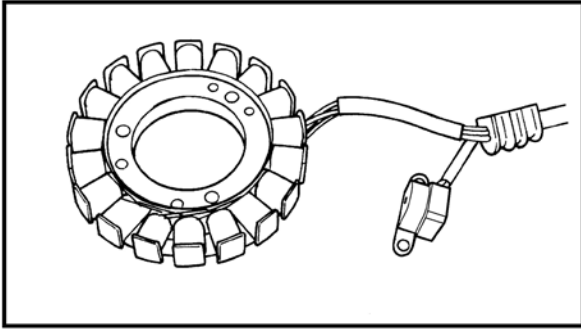

### 1. CHECK

#### 1). Checking the A.C. magneto

- stator coil
- pickup coil

Damage → Replace.

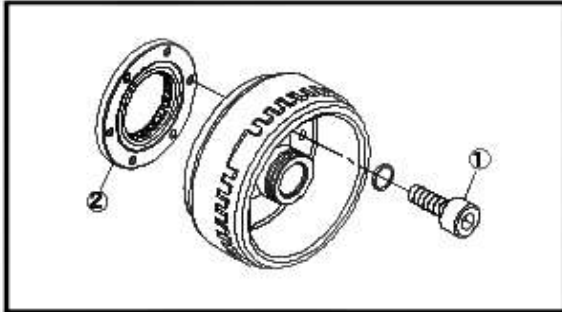

#### 2). Checking the starter clutch

- starter clutch ①  
Cracks/damage → Replace.
- starter clutch bolts ②  
Loose → Replace with new ones, and clinch the end of the bolts.

### NOTE:

• The arrow mark on the starter clutch must face inward, away from the A.C. magneto rotor.

• When installing, apply the locking agent.

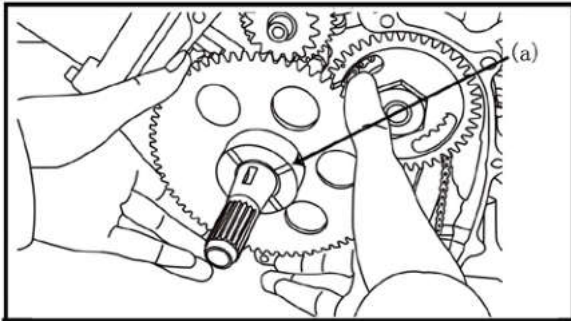

a. Install the starter wheel gear onto the starter clutch, and hold the starter clutch.

### NOTE:

Install the starter wheel gear with the groove (a) facing the A.C. magneto rotor.

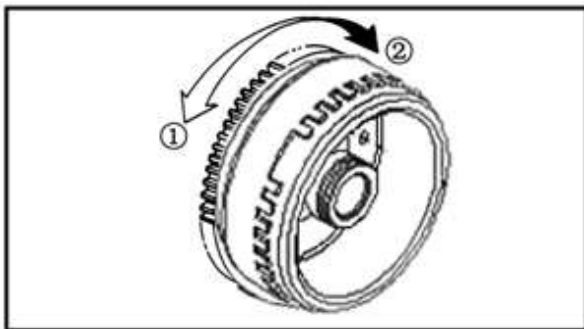

b. Turn the starter wheel gear counterclockwise ① to check that the starter clutch and wheel gear engage.

If the starter clutch and wheel gear do not engage, replace the starter clutch.

c. Turn the starter wheel gear clockwise ② to check the starter wheel gear for smooth operation.

If operation is not smooth, replace the starter clutch.

## 750UTV ENGINE

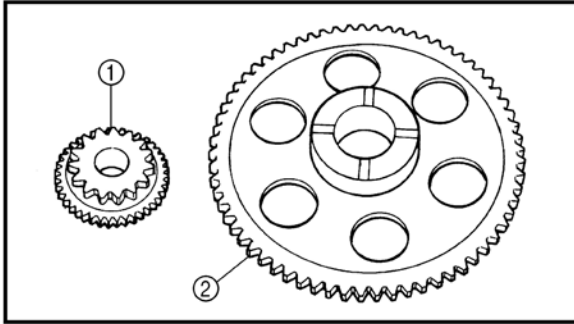

- starter idle gear teeth ①
- starter wheel gear teeth ②

Burrs/clips/roughness/wear → Replace.

- starter wheel gear  
(contacting surface)  
Damage/pitting/wear → Replace.

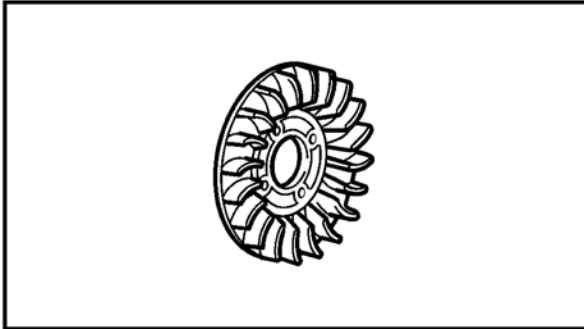

### 3). Checking the engine cooling fan

- engine cooling fan
- air shroud 1
- air shroud 2
- Cracks/damage → Replace.

## 2. INSTALL

- woodruff key
- A.C. magneto rotor

### **NOTE:**

- Before installing the rotor, clean the outside of the crankshaft and the inside of the rotor.
- After installing the rotor, check that the rotor rotates smoothly. If not, reinstall the key and rotor.

- dowel pins
- gasket (New replacement)
- A.C. magneto cover(10Nm)

### **NOTE:**

- When installing the A.C. magneto cover, use a long rod to hold the A.C. magneto rotor in position from the outside. This will make assembly easier. Be careful not to damage the oil seal.
- Apply sealant (Quick Gasket) ① to the thread of the bolt ② shown in the illustration.
- Tighten the bolts in stages, using a crisscross pattern.

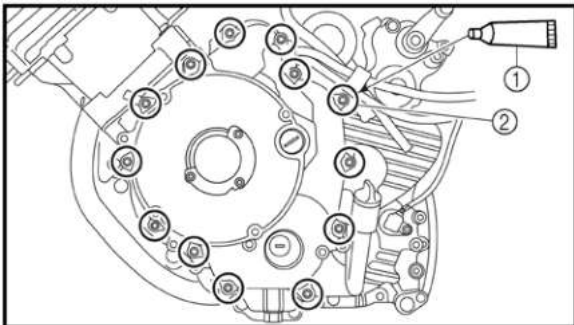

## 750UTV ENGINE

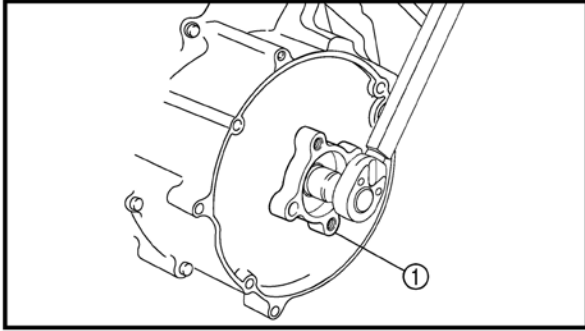

- engine cooling fan pulley ①(55Nm)

**NOTE:**

Before installing the engine cooling fan pulley, do not forget to install the O-ring.

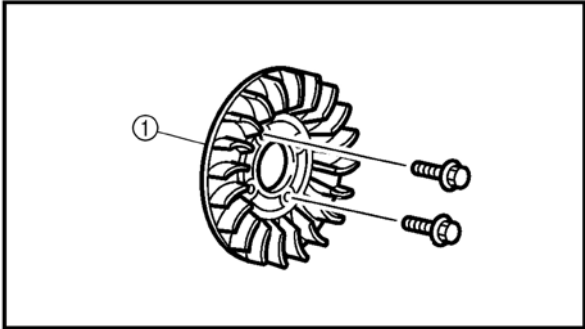

- engine cooling fan ① (7Nm)

**NOTE:**

Install the bolts in the holes in the collar of the engine cooling fan.

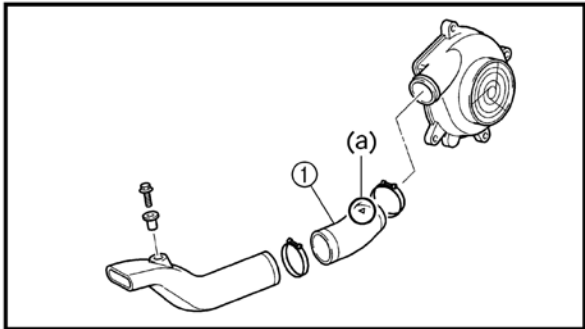

- air shroud ① (10Nm)

- engine cooling fan air duct assembly ①

**NOTE:**

Install the engine cooling fan air duct assembly with the arrow mark (a) towards the air shroud ①.



## 750UTV ENGINE

### BALANCER GEARS AND OIL PUMP GEARS

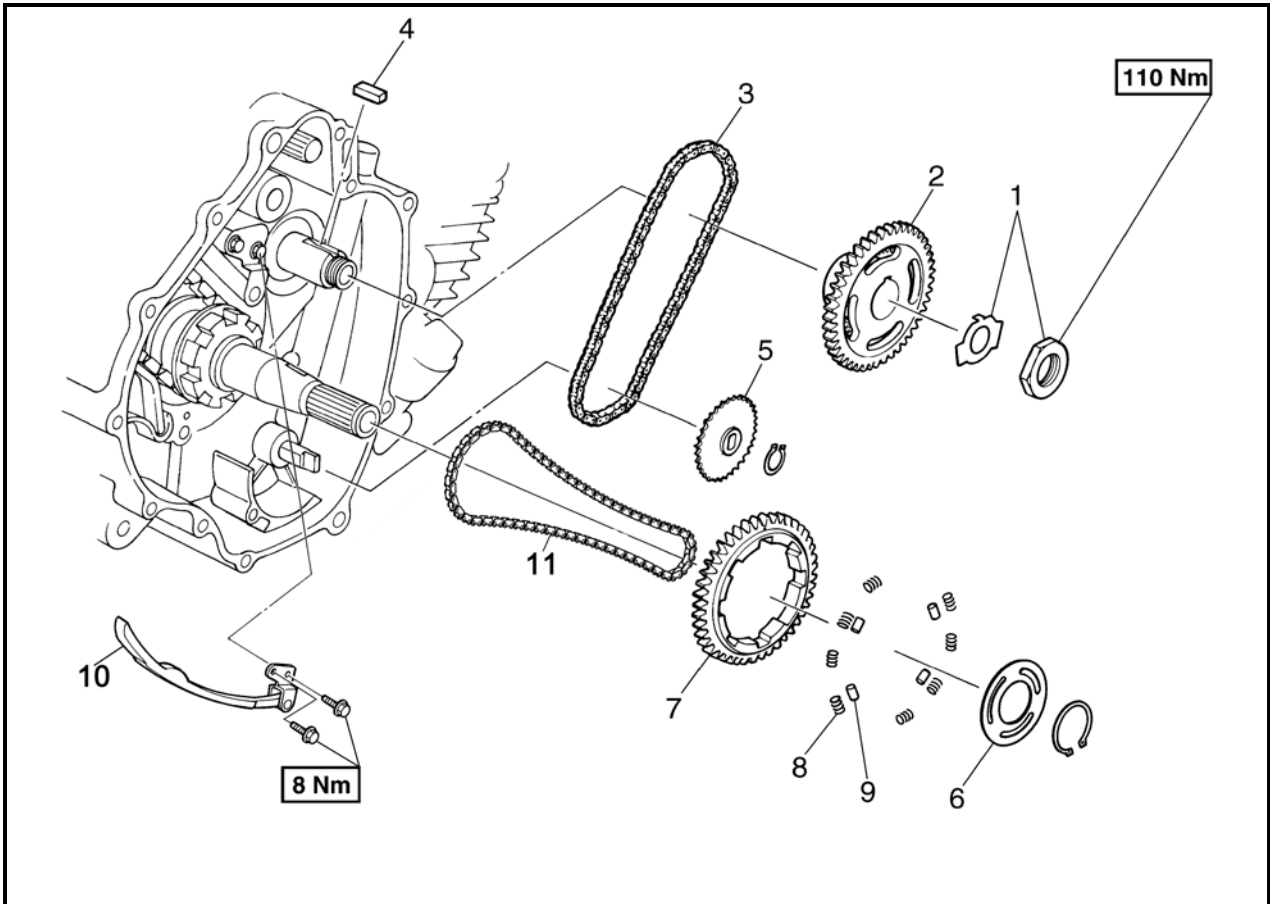

No.	Part Name	Qty	Remarks
	<b>Removing the balancer gears and oil pump gears</b>		Remove the parts in the order listed.
1	Nut/lock washer	1/1	
2	Balancer driven/oil pump drive gear	1	
3	Chain	1	
4	Straight key	1	
5	Oil pump driven gear	1	
6	Plate	1	
7	Balancer drive gear	1	
8	Spring	8	
9	Pin	4	
10	Timing chain guide (intake side)	1	
11	Timing chain	1	
			For installation, reverse the removal procedure.

# ENGINE

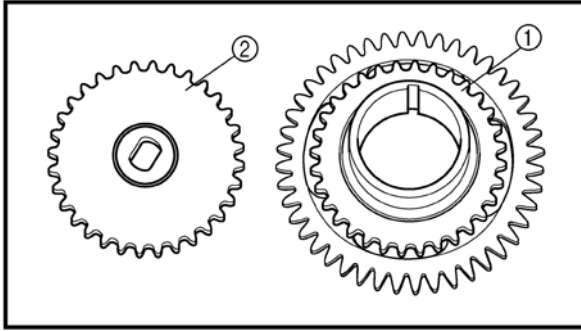

## 1、CHECK

1) Checking the oil pump drive gear and oil pump driven gear

- oil pump drive gear ①
- oil pump driven gear ②

Cracks/wear/damage → Replace

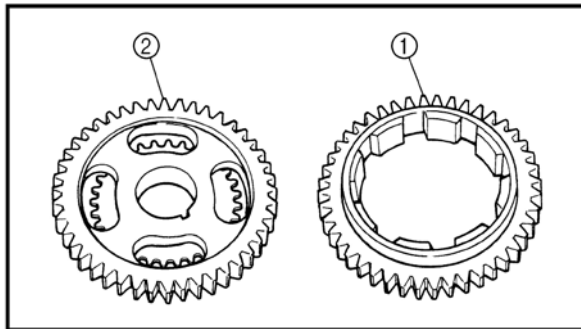

2).Checking the balancer drive gear and balancer driven gear

- balancer drive gear ①
- balancer driven gear ②

Damage/wear → Replace the balancer drive gear and balancer driven gear as a set.

Excessive noise during operation → Replace the balancer drive gear and balancer driven gear as a set.

3). Checking the timing chain and guides

- timing chain

Cracks/stiff → Replace the timing chain and camshaft sprocket as a set.

- timing chain guides

Wear/damage → Replace.

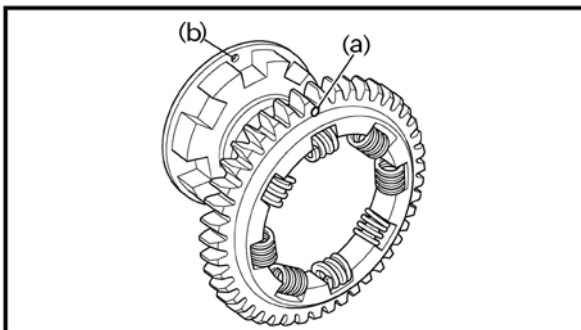
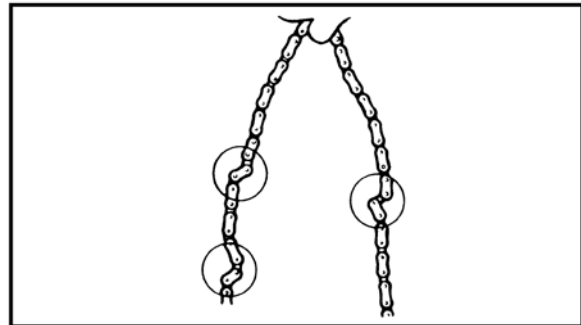

## 2、INSTALL

- pins
- springs
- balancer drive gear (onto the buffer boss)
- plate
- circlip

### NOTE:

Align the punch mark (a) on the balancer drive gear with the hole (b) to the buffer boss.

## ENGINE

---

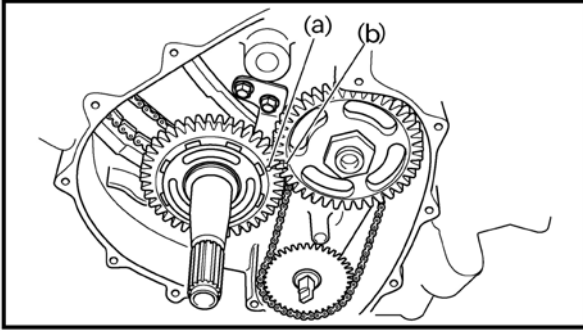

- balancer driven gear

---

**NOTE:**

Align the punch mark (a) on the balancer drive gear with the punch mark (b) on the balancer driven gear.

---

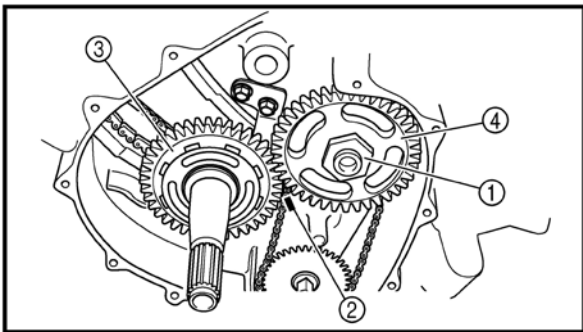

- lock washer(new replacement)
- balancer driven gear nut ①(110Nm)

---

**NOTE:**

- Place an aluminum plate ② between the teeth of the balancer drive gear ③ and balancer driven gear ④.
  - Apply the molybdenum disulfide grease to the thread of axle and nut.
-

# ENGINE

## PRIMARY AND SECONDARY SHEAVES

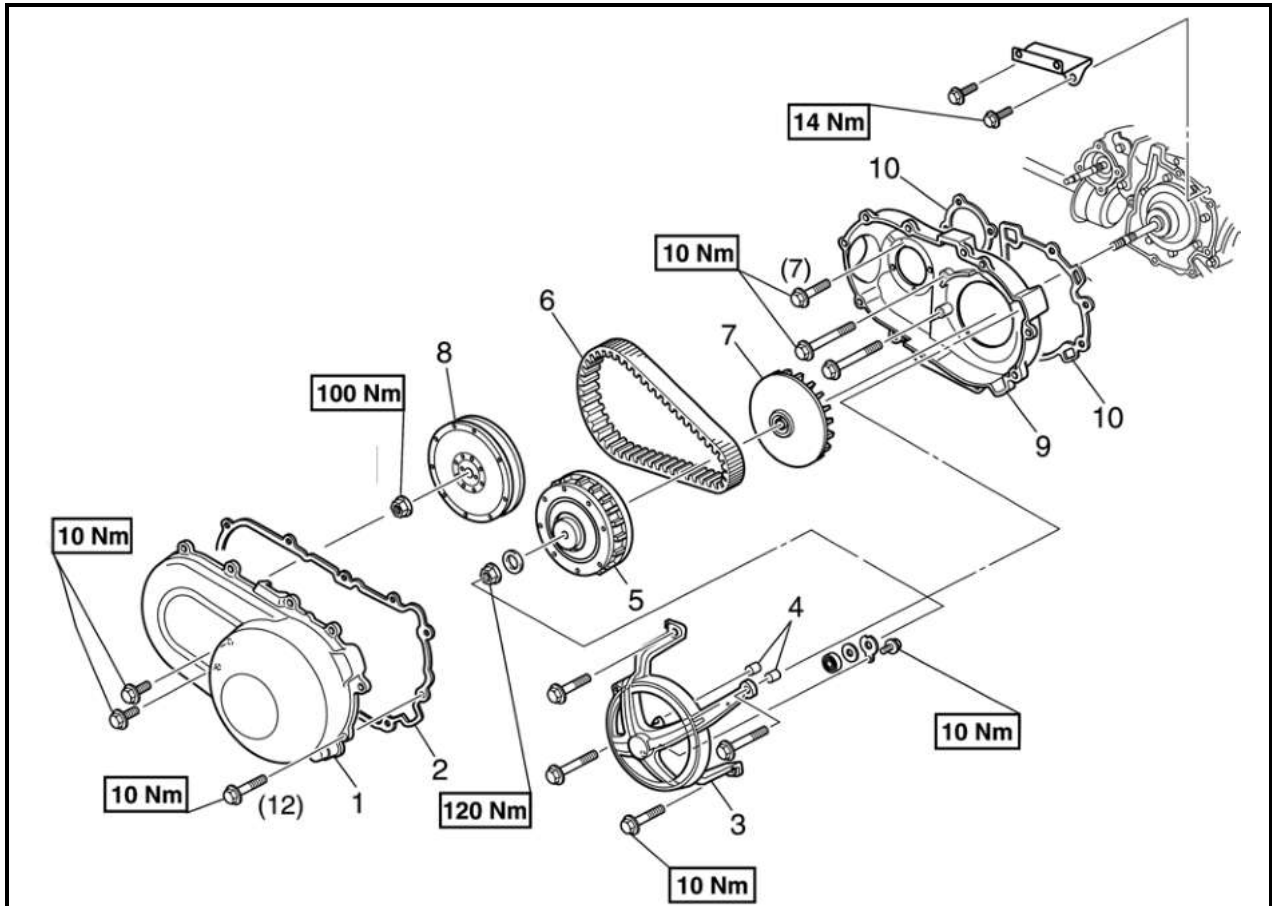

No.	Part Name	Qty	Remarks
	<b>Removing the primary and secondary sheaves</b>		Remove the parts in the order listed.
	Engine assembly		
1	Drive belt cover	1	
2	Rubber gasket	1	
3	Bearing housing	1	
4	Dowel pin	2	
5	Primary sheave assembly	1	
6	V-belt	1	
7	Primary fixed sheave	1	
8	Secondary sheave assembly	1	
9	Drive belt case	1	
10	Rubber gasket	2	
			For installation, reverse the removal procedure.

# ENGINE

## PRIMARY SHEAVE

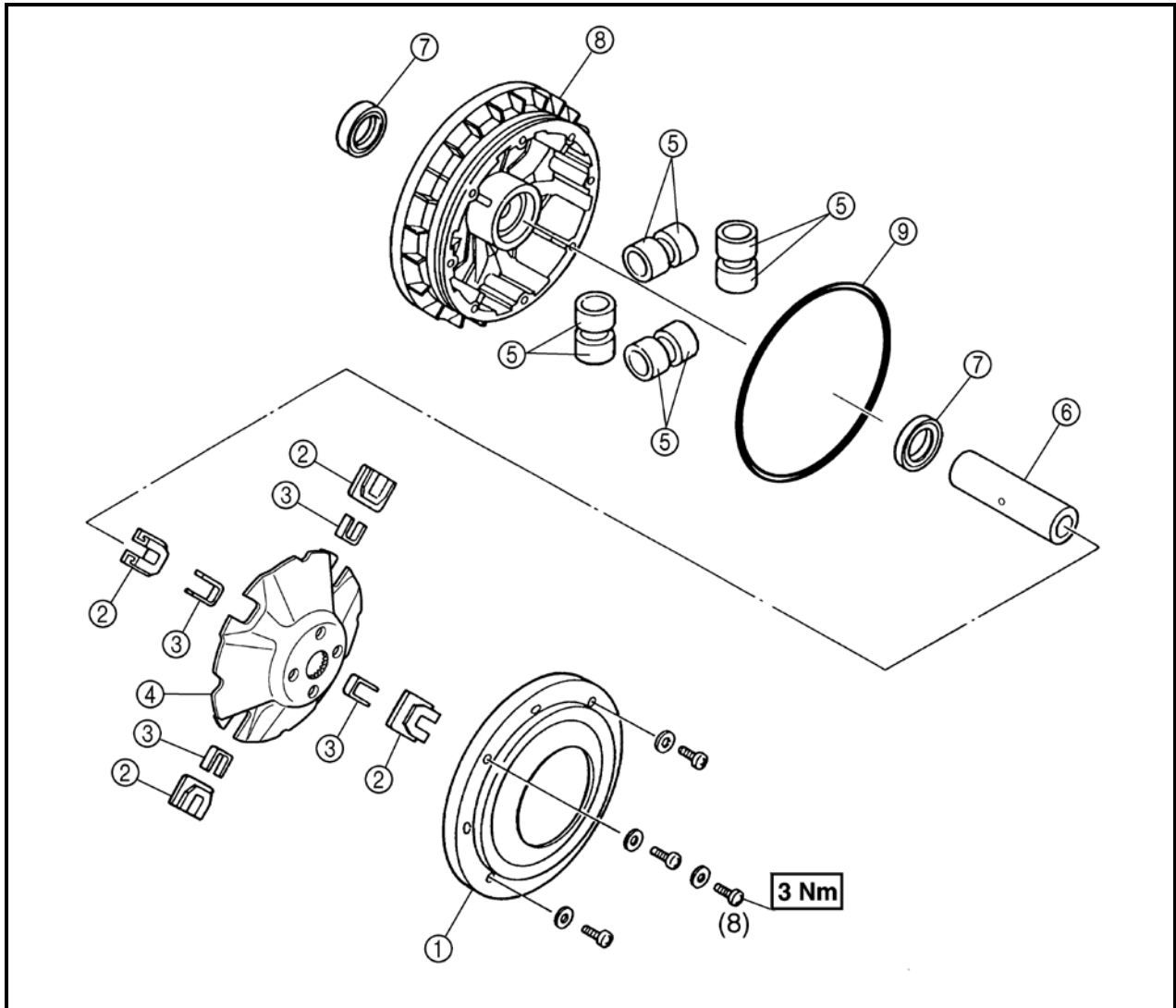

No.	Part Name	Qty	Remarks
	<b>Disassembling the primary sheave</b>		Remove the parts in the order listed.
1	Primary pulley sheave cap	1	
2	Primary pulley slider	4	
3	Spacer	4	
4	Primary pulley cam	1	
5	Primary pulley weight	8	
6	Collar	1	
7	Oil seal	2	
8	Primary sliding sheave	1	
9	O-ring	1	
			For assembly, reverse the disassembly procedure.

# ENGINE

## SECONDARY SHEAVE

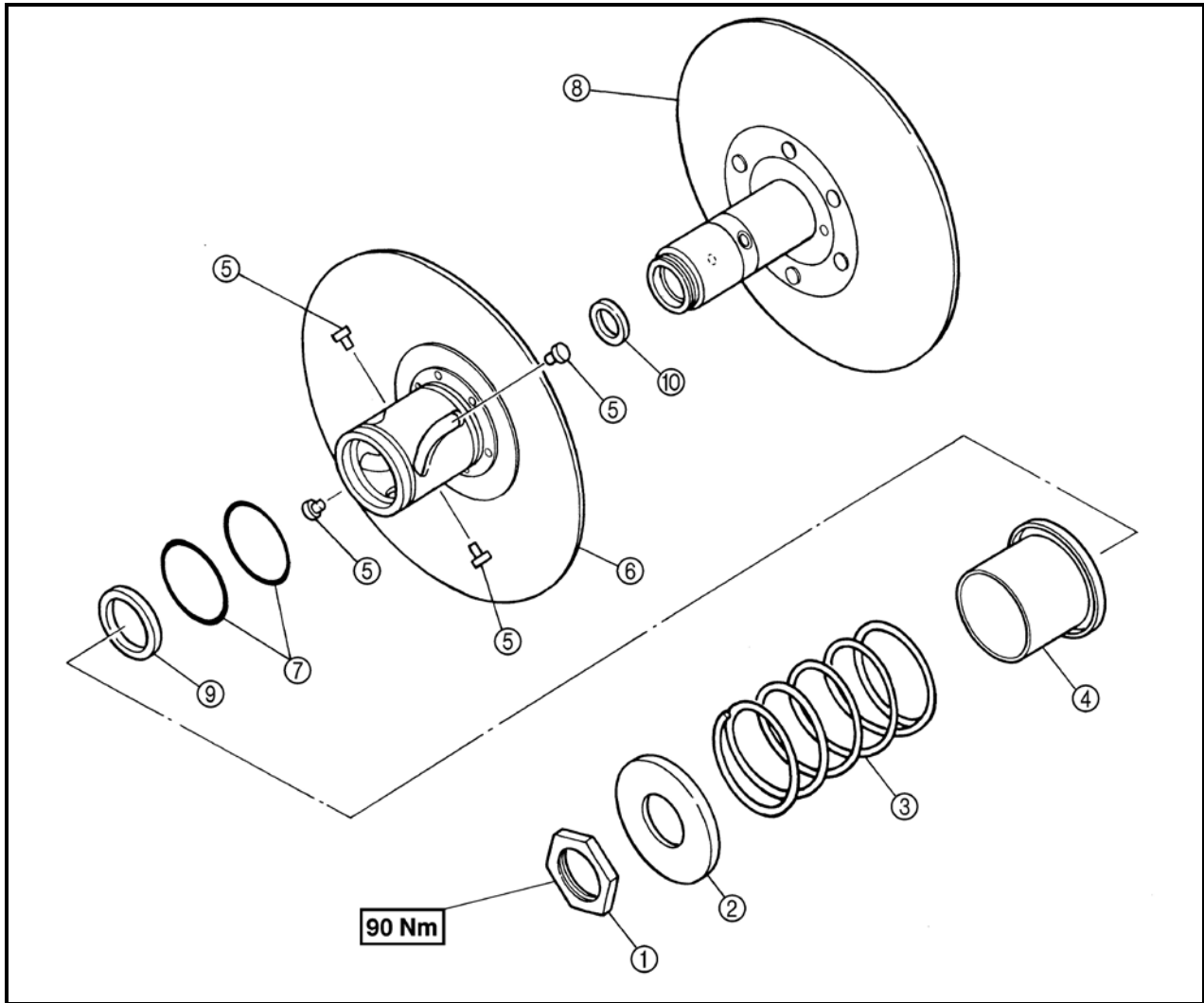

No.	Part Name	Qty	Remarks
	<b>Disassembling the secondary Sheave</b>		Remove the parts in the order listed.
1	Nut	1	
2	Spring seat	1	
3	Compression spring	1	
4	Spring seat	1	
5	Guide pin	4	
6	Secondary sliding sheave	1	
7	O-ring	2	
8	Secondary fixed sheave	1	
9	Oil seal	1	
10	Oil seal	1	
			For assembly, reverse the disassembly procedure.

# ENGINE

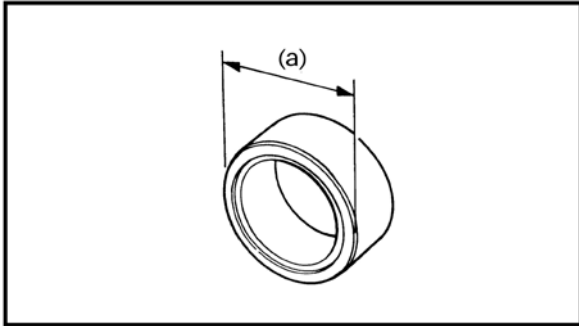

## 1. Check

### 1). Checking the primary sheave

- weight outside diameter (a)

Out of specification → Replace the weight.

**Weight outside diameter limit: 29.5 mm**

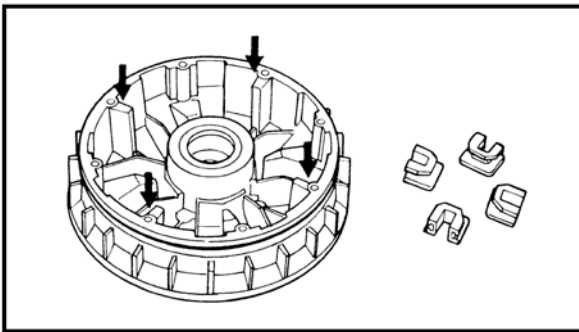

- primary pulley slider
- primary sliding sheave splines  
Wear/cracks/damage → Replace.
- spacer
- primary pulley cam  
Cracks/damage → Replace.

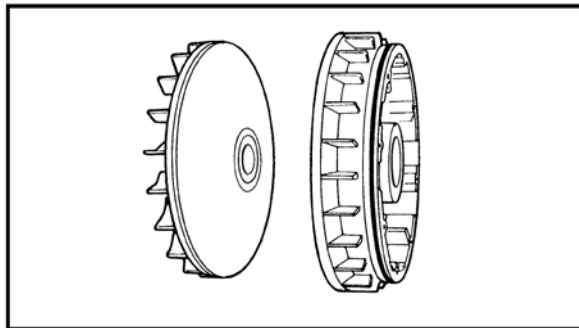

- primary sliding sheave
- primary fixed sheave  
Cracks/damage → Replace.

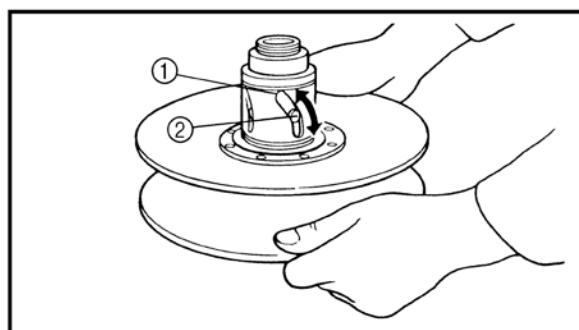

### 2). Checking the secondary sheave

- secondary fixed sheave smooth operation
- secondary sliding sheave smooth operation  
Scratches/damage → Replace as a set.
- torque cam grooves ①  
Wear/damage → Replace
- guide pins ②  
Wear/damage → Replace.
- secondary sheave spring  
Damage → Replace.

## ENGINE

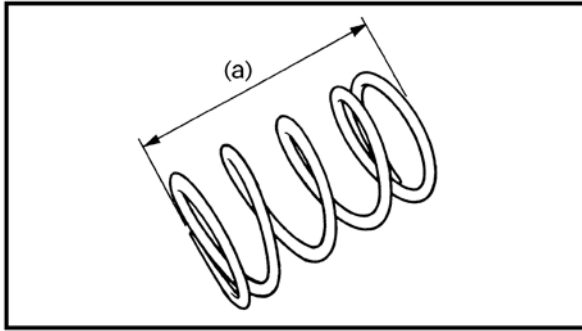

### 2、 Measure

- secondary sheave spring free length (a)
- Out of specification → Replace the secondary sheave spring.

### 3、 INSTALL

#### 1). Assembling the primary sheave

##### (1) Clean:

- primary sliding sheave face ①
- primary fixed sheave face ②
- collar ③
- weights ④
- primary sliding sheave cam face

##### **NOTE:**

**Remove any excess grease.**

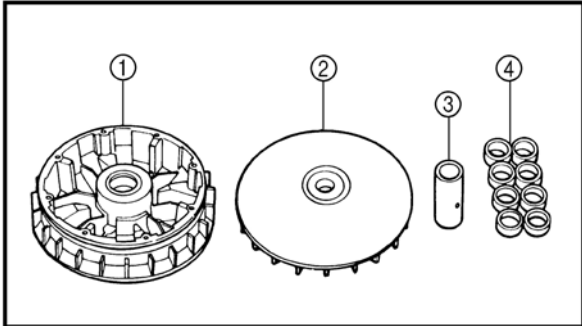

##### (2) Install:

- weights ①

##### **NOTE:**

- **Apply grease (90g) to the whole outer surface of the weights and install.**
- **Apply grease to the inner surface of the collar.**
- **Apply grease to the inner surface of the primary sliding sheave.**

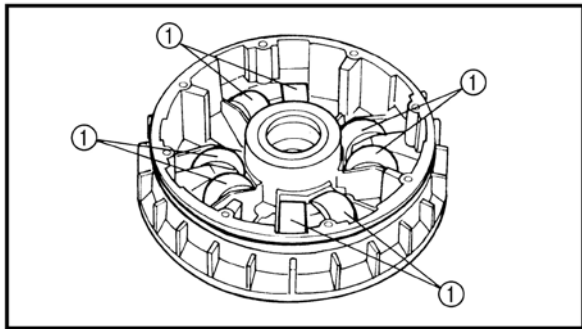

- spacer
- sliders ①
- primary pulley cam ②
- primary sliding sheave cap (3 Nm)

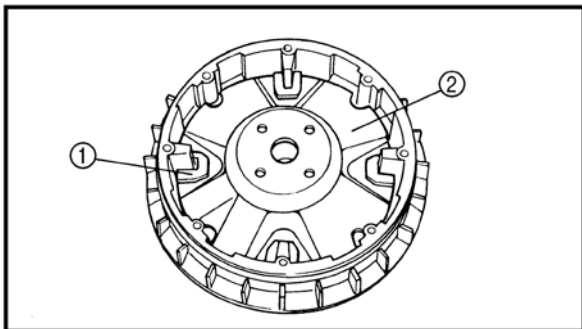



## ENGINE

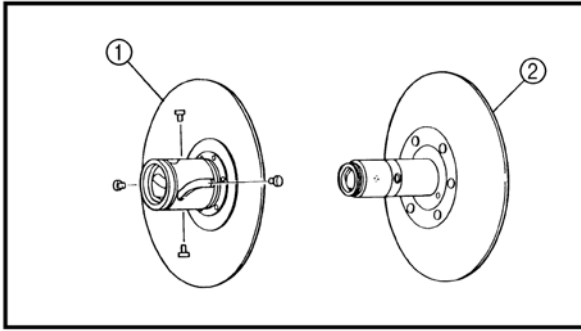

### 2). Assembling the secondary sheave

#### (1)Apply:

- assembly lube  
(to the secondary sliding sheave ① inner surface and oil seals).
- assembly lube  
(to the bearings, oil seals and inner surface of the secondary fixed sheave ②)

#### (2)Install:

- guide pins ①
- spring seat
- compression spring
- spring seat
- nut

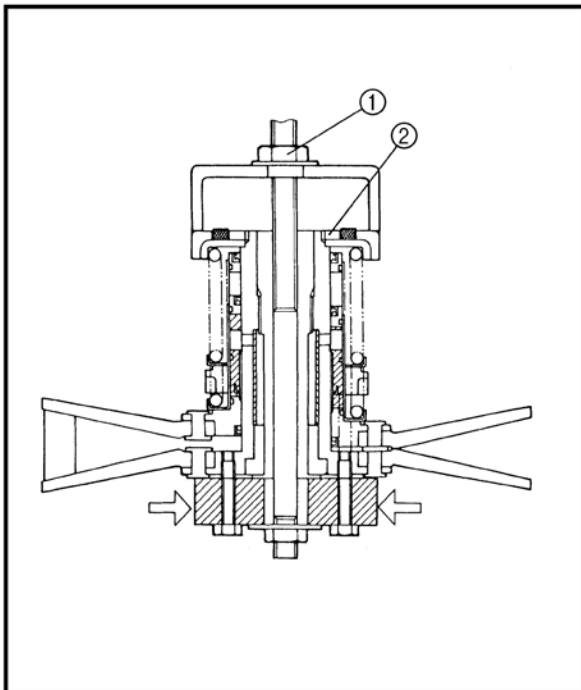
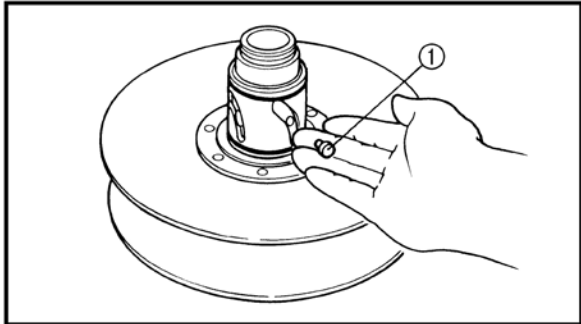

a. Attach the sheave fixed block, locknut wrench and sheave spring compressor to the secondary sheave assembly.

b. Place the sheave fixed block in a vise and secure it.

c. Tighten the sheave spring compressor nut ① and compress the spring.

d. Install the nut ② torque using the locknut wrench.(Nut:90Nm)

e. Remove the sheave spring compressor, locknut wrench, and sheave fixed block.

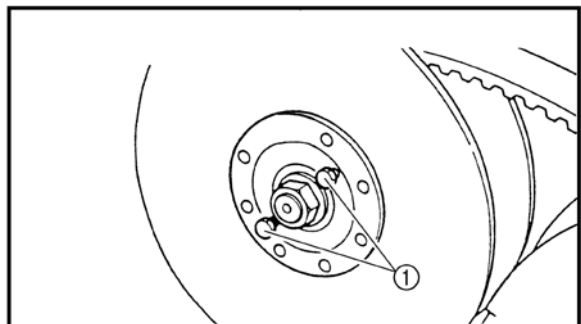

### 3). Installing the primary and secondary sheaves

#### (1) Install:

- secondary sheave assembly
- V-belt
- primary sheave assembly

## ENGINE

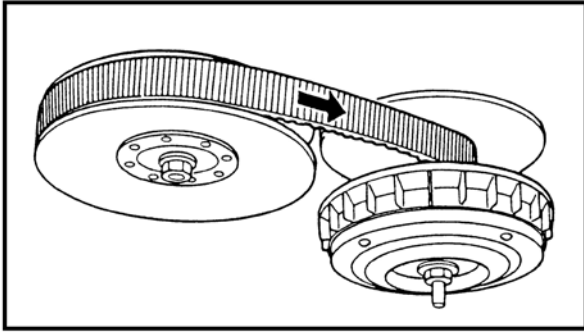

---

**NOTE:**

- Tightening the bolts ① will push the secondary sliding sheave away, causing the gap between the secondary fixed and sliding sheaves to widen.
  - Install the V-belt so that its arrow faces the direction show in the illustration.
- 

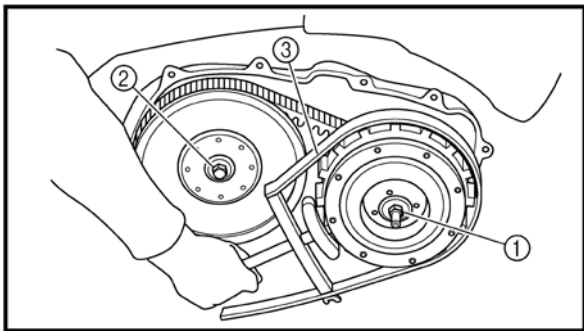

(2)Tighten:

- primary sheave nut ①(120Nm)
- secondary sheave nut ②(100Nm)

---

**NOTE:**

- Use the sheave holder ③ to hold the primary sheave.
  - First, tighten the primary sheave nut ①, then tighten the secondary sheave nut ②.
-

# ENGINE

## CLUTCH

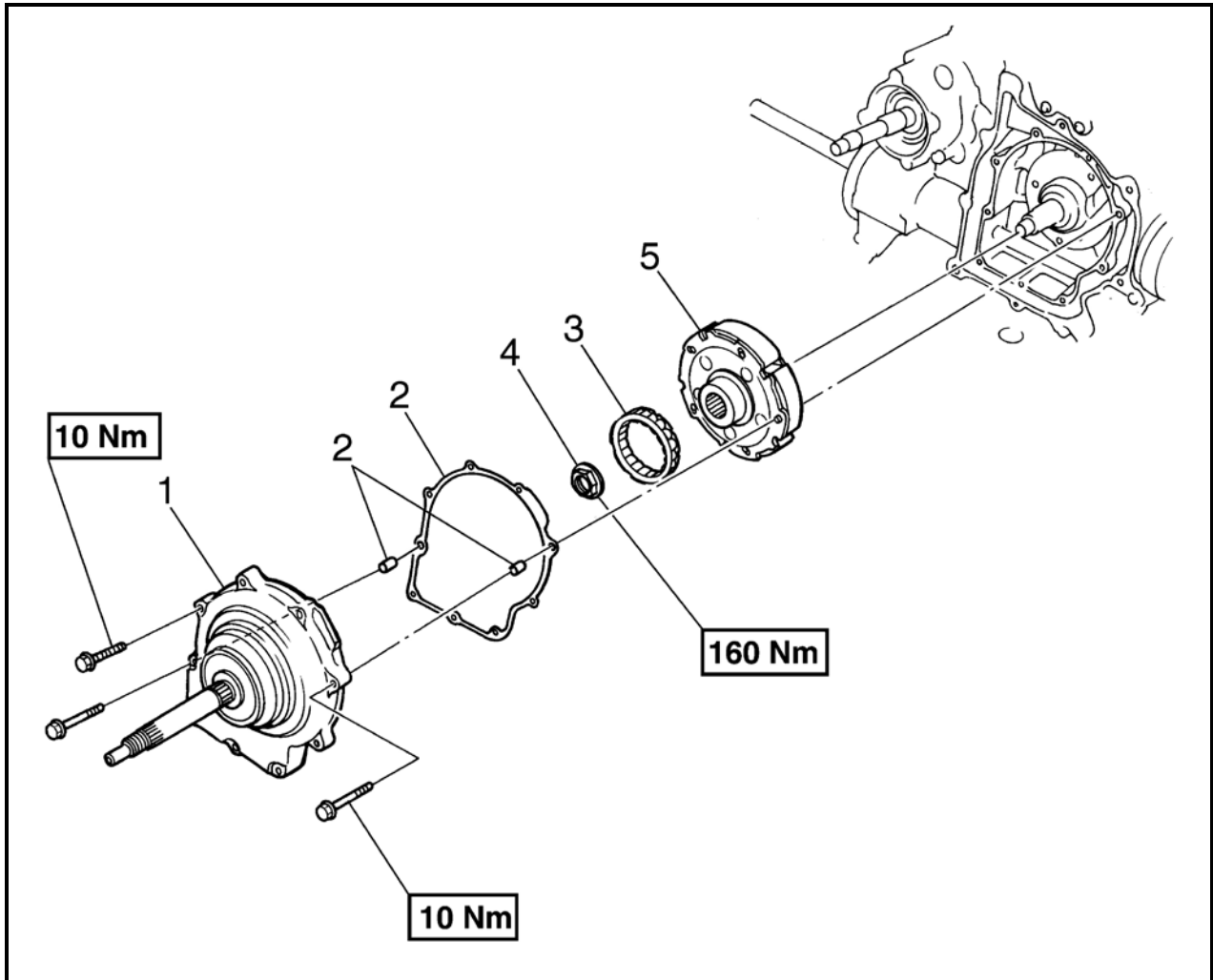

No.	Part Name	Qty	Remarks
	<b>Removing the clutch</b>		
	Primary and secondary sheaves		Remove the parts in the order listed.  For installation, reverse the removal procedure.
1	Clutch housing assembly	1	
2	Gasket/dowel pin	1/2	
3	One-way clutch bearing	1	
4	Nut	1	
5	Clutch carrier assembly	1	

# ENGINE

## CLUTCH HOUSING

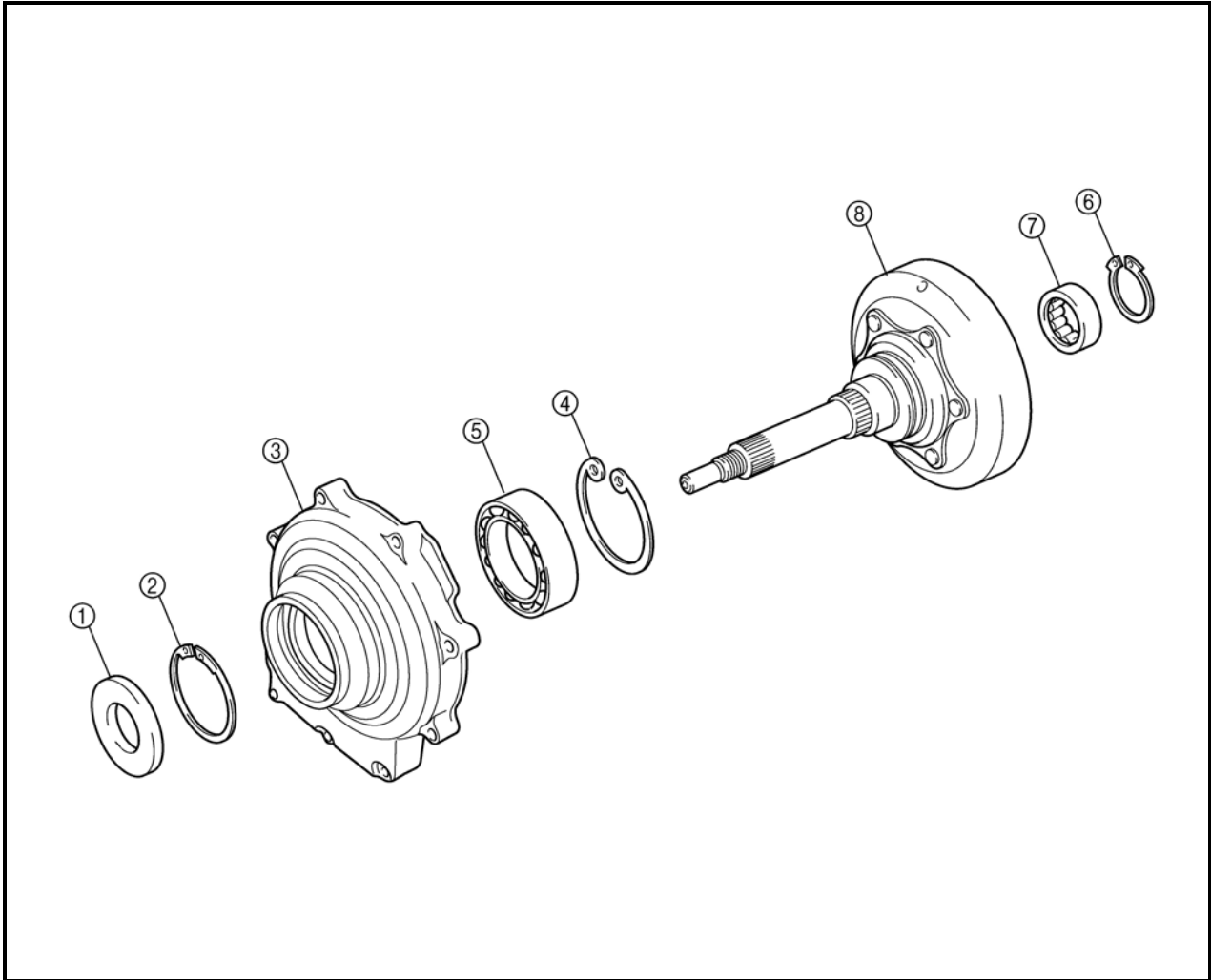

No.	Part Name	Qty	Remarks
	<b>Disassembling the clutch housing</b>		Remove the parts in the order listed.
1	Oil seal	1	
2	Circlip	1	
3	Bearing housing	1	
4	Circlip	1	
5	Bearing	1	
6	Circlip	1	
7	Bearing	1	
8	Clutch housing	1	
			For assembly, reverse the disassembly procedure.

# ENGINE

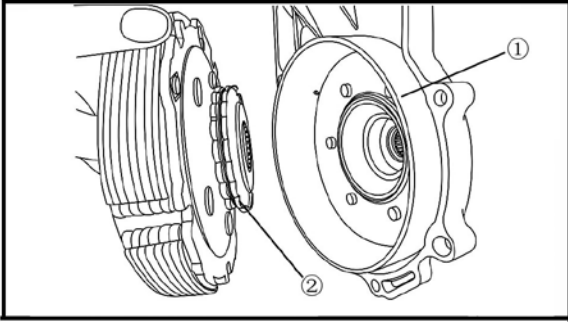

## 1、CHECK

### 1). Checking the clutch

- clutch housing ①  
Heat damage/wear/damage → Replace.
- one-way clutch bearing ②  
Chafing/wear/damage → Replace.

### **NOTE:**

- **Replace the one-way clutch assembly and clutch housing as a set.**
- **The one-way clutch bearing must be installed with the flange side facing in.**

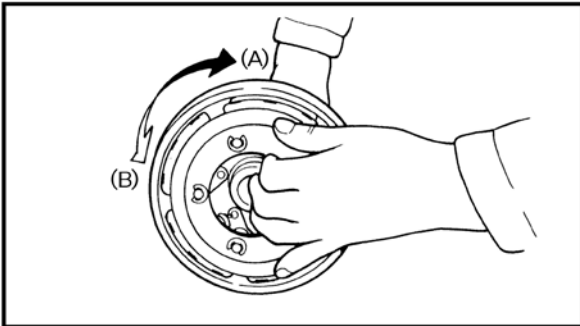

- Install the one-way clutch bearing and clutch carrier assembly to the clutch housing and hold the clutch carrier assembly.
  - When turning the clutch housing clockwise (A), the clutch housing should turn freely. If not, the one-way clutch assembly is faulty. Replace it.
  - When turning the clutch housing counter-clockwise (B), the clutch housing and crankshaft should be engaged. If not, the one-way clutch assembly is faulty. Replace it.
- clutch shoe  
Heat damage → Replace.

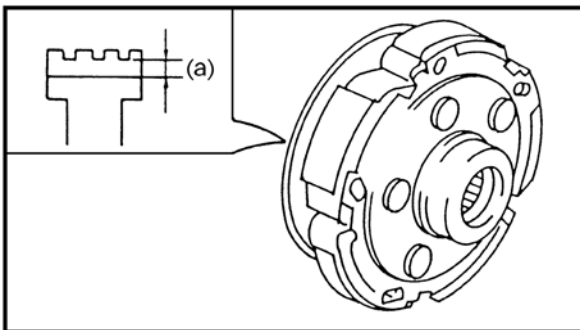

## 2、MEASURE

- clutch shoe thickness  
Out of specification → Replace.

**Clutch shoe wear limit (a)**

**1.0 mm**

## ENGINE

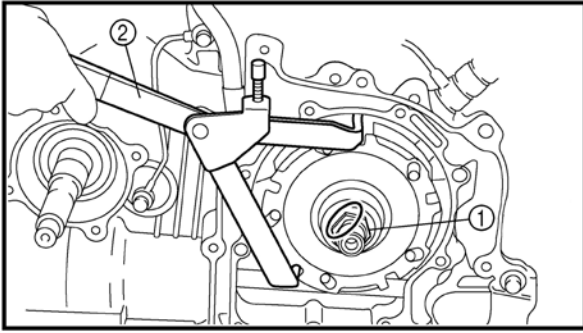

### 3、INSTALL

- clutch carrier assembly
- nut ①(160Nm)

#### **NOTE:**

**Use a universal clutch holder ②  
clutch carrier assembly.**

- Lock the threads with a drift punch.

- one-way clutch bearing

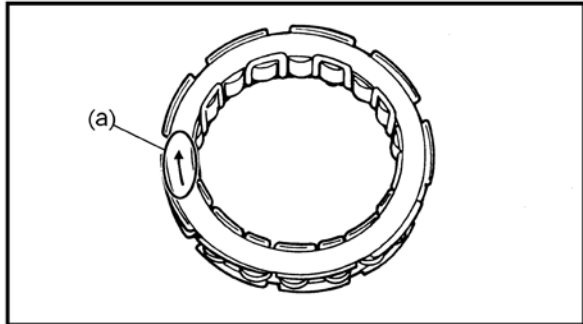

#### **NOTE:**

**The one-way clutch bearing should be installed in the clutch carrier assembly with the arrow mark (a) facing toward the clutch housing.**

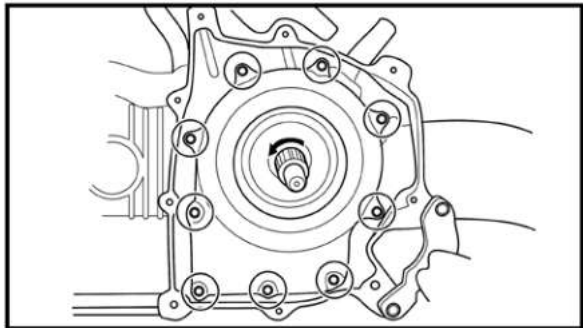

- dowel pins
- gasket
- clutch housing assembly  
(10 Nm)

#### **NOTE:**

- Tighten the bolts in stages, using a crisscross pattern.
- After tightening the bolts, check that the clutch housing assembly to counterclockwise rotates smoothly.

# ENGINE

## CRANKCASE STARTER MOTOR AND OIL FILTER

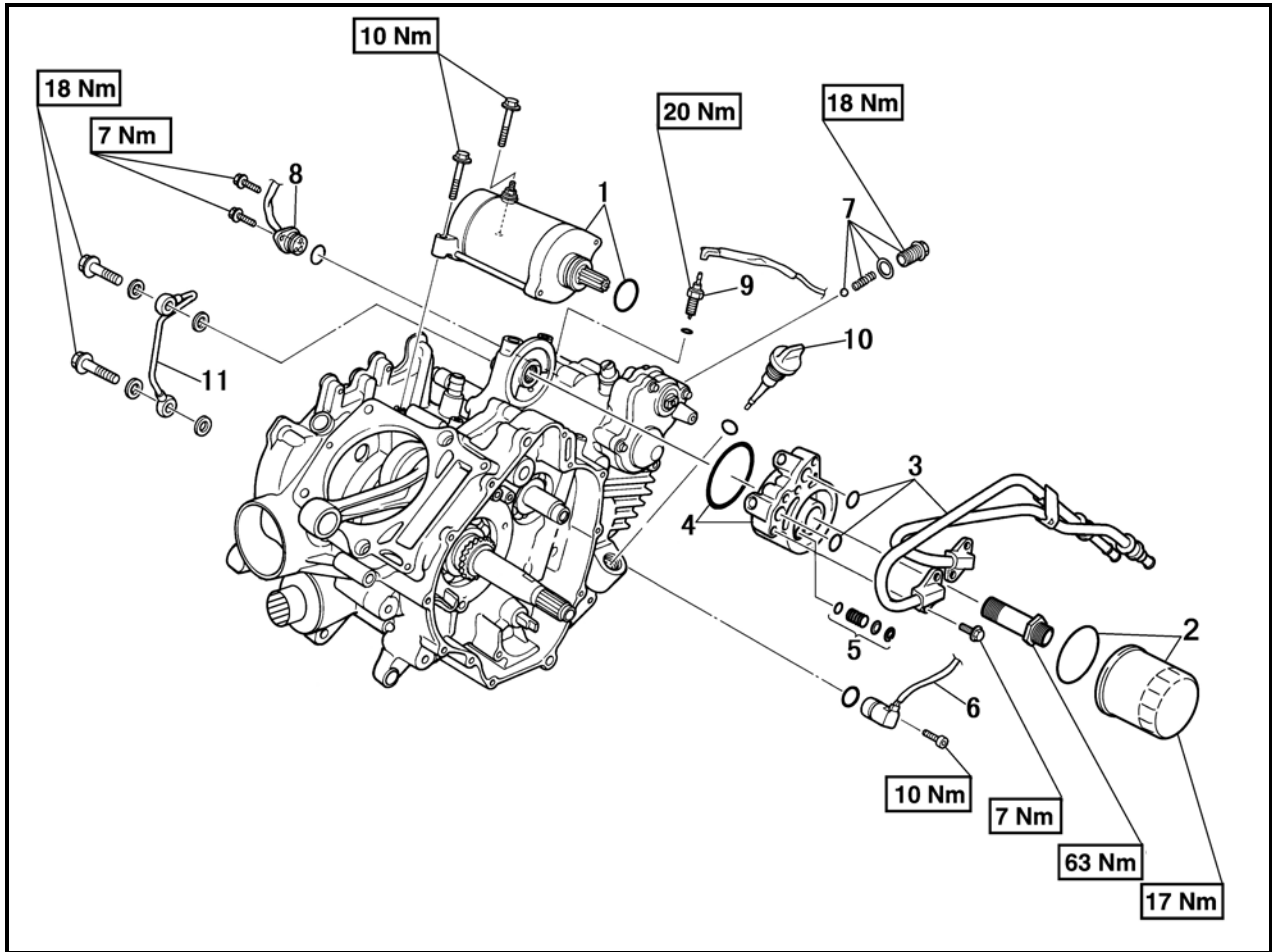

No.	Part Name	Qty	Remarks
	<b>Remove the starter motor, timing chain and oil filter</b>		Remove the parts in the order listed.
	A.C. magneto rotor		
	Primary and secondary sheaves		
	Clutch carrier assembly		
1	Starter motor/O-ring	1/1	
2	Oil filter cartridge/O-ring	1	
3	Oil pipe assembly/O-ring	1/2	
4	Oil pipe adapter/O-ring	1/1	
5	Relief valve assembly	1	
6	Speed sensor	1	
7	Shift drum stopper	1	
8	Gear position switch	1	

# ENGINE

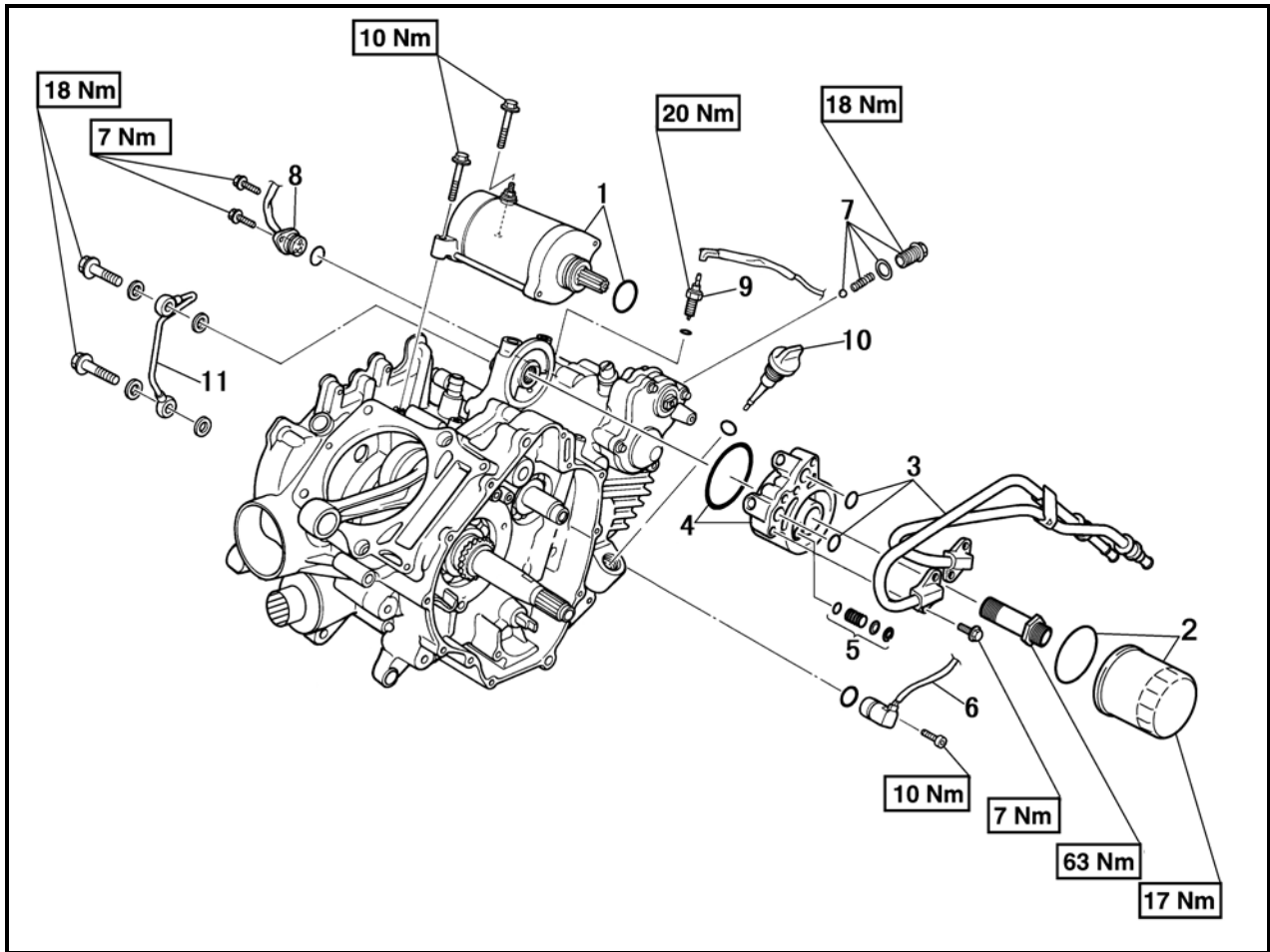

No.	Part Name	Qty	Remarks
9	Reverse switch	1	For installation, reverse the removal procedure.
10	Oil filler cap	1	
11	Oil delivery pipe 1	1	



# ENGINE

## CRANKCASE

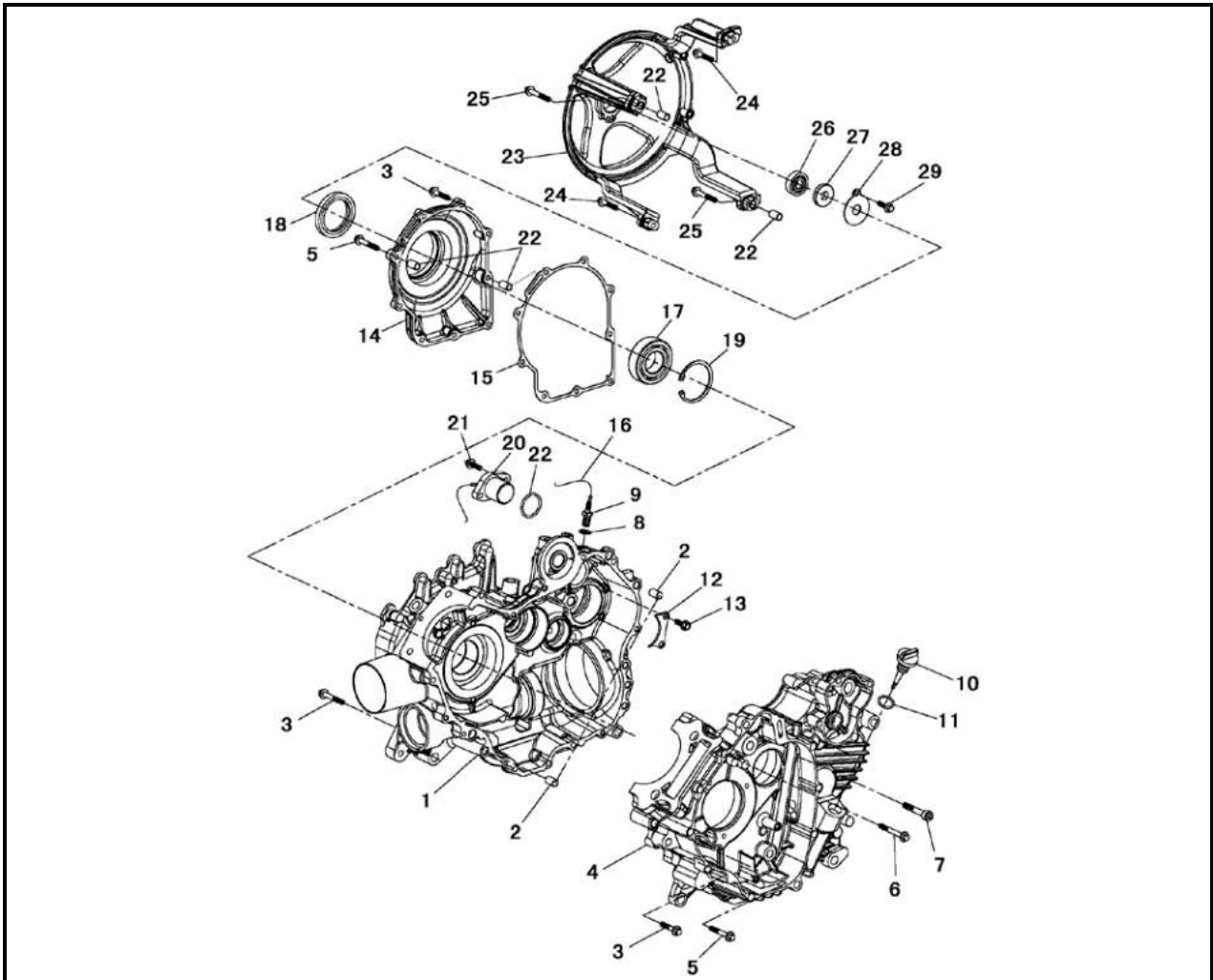

No.	Part Name	Qty	Remarks
	Separating the crankcase		Remove the parts in the order listed.
1	Right crankcase comp	1	
2	Dowel Pin $\phi 9 \times \phi 12 \times 16$	2	
3	Flange bolt M6 $\times$ 30	19	
4	Left crankcase comp	1	
5	Flange bolt M6 $\times$ 40	4	
6	Flange bolt M6 $\times$ 55	1	
7	Inner hexangular screw M8 $\times$ 40	3	
8	Gear switch	1	
9	Washer $\phi 10 \times \phi 16 \times 1$	1	
10	Gauge oil level	1	
11	O-ring 18 $\times$ 2.4	1	
12	Press plate-main shaft bearing	1	

# ENGINE

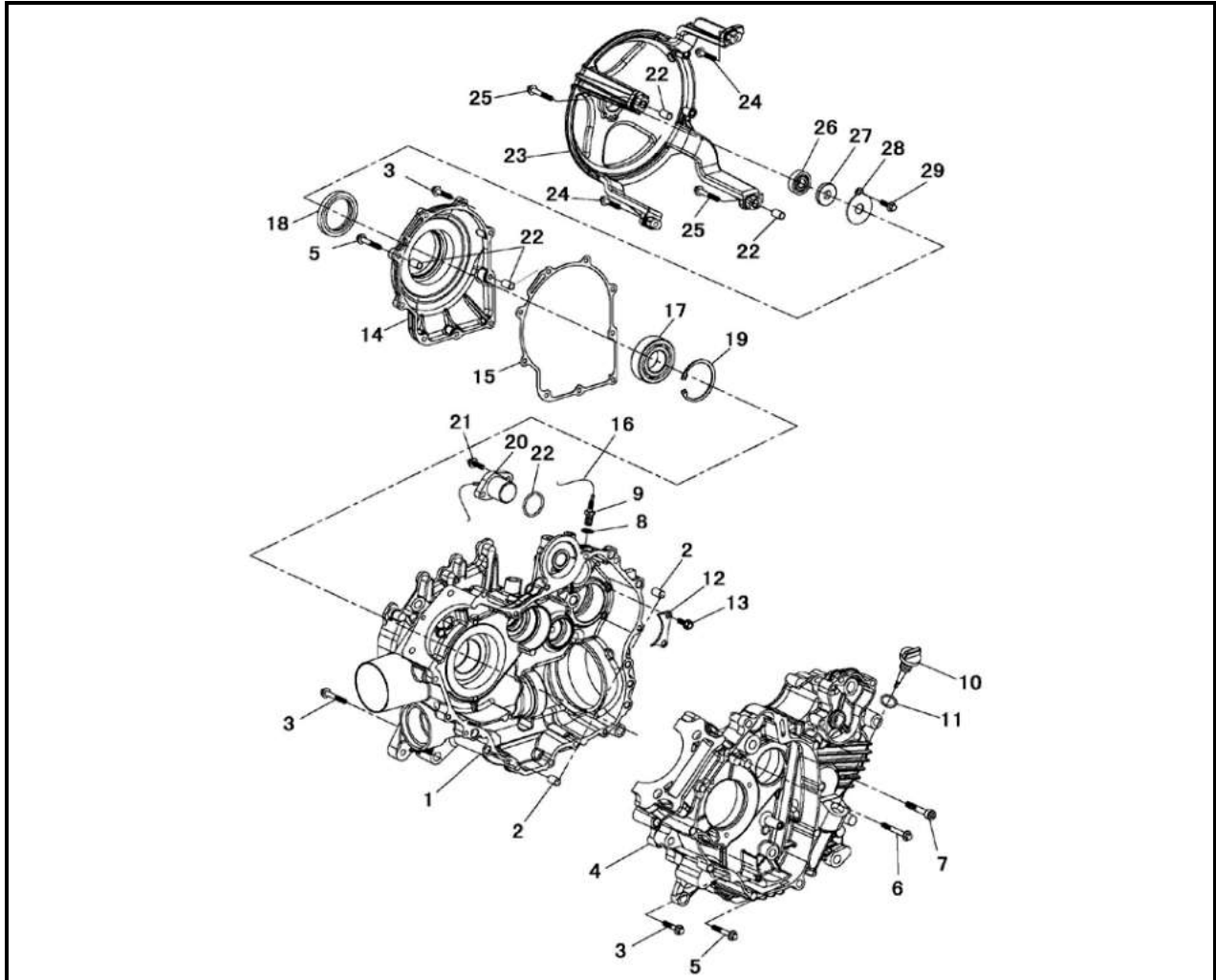

No.	Part Name	Qty	Remarks
13	Flange bolt M6×16	2	
14	Bearing seat outer cover	1	
15	Seal cushion bearing seat	1	
16	Leads Gear	1	
17	Bearing 16010	1	
18	Oil seal 35×65×9	1	
19	Circlip φ 80	1	
20	Gear show assy	1	
21	Bolt M6×16	2	
22	Flange bolt M6×20	2	
23	Protection cover brack tcluth	1	
24	Flange bolt M6×32	2	
25	Flange bolt M6×40	2	

# ENGINE

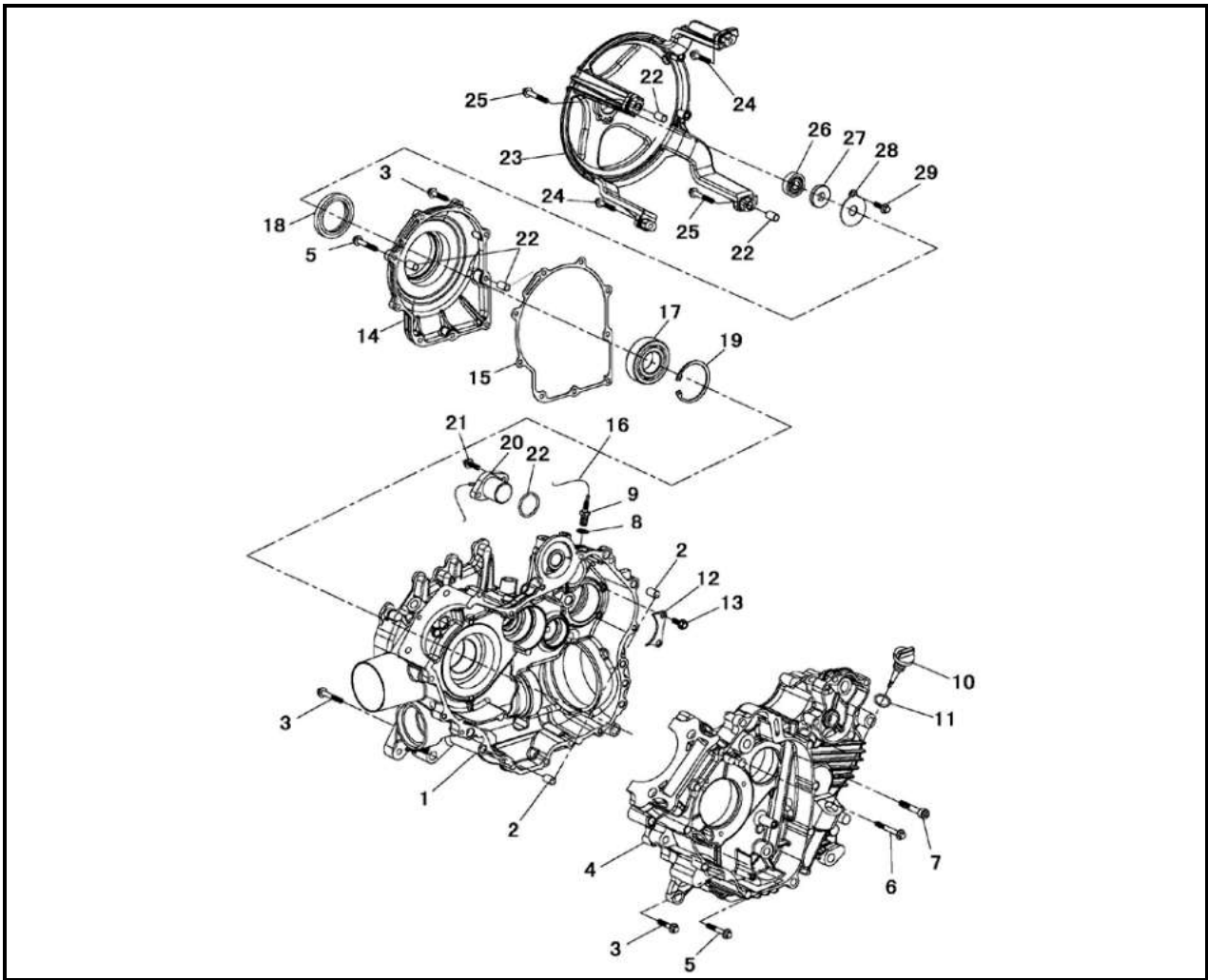

No.	Part Name	Qty	Remarks
26	Bearing 62012Z	1	
27	Oil seal 12x32x6	1	
28	Oil press plate	1	
29	Flange bolt M6x12	1	
			For installation, reverse the removal procedure.

# ENGINE

## CRANKCASE BEARINGS

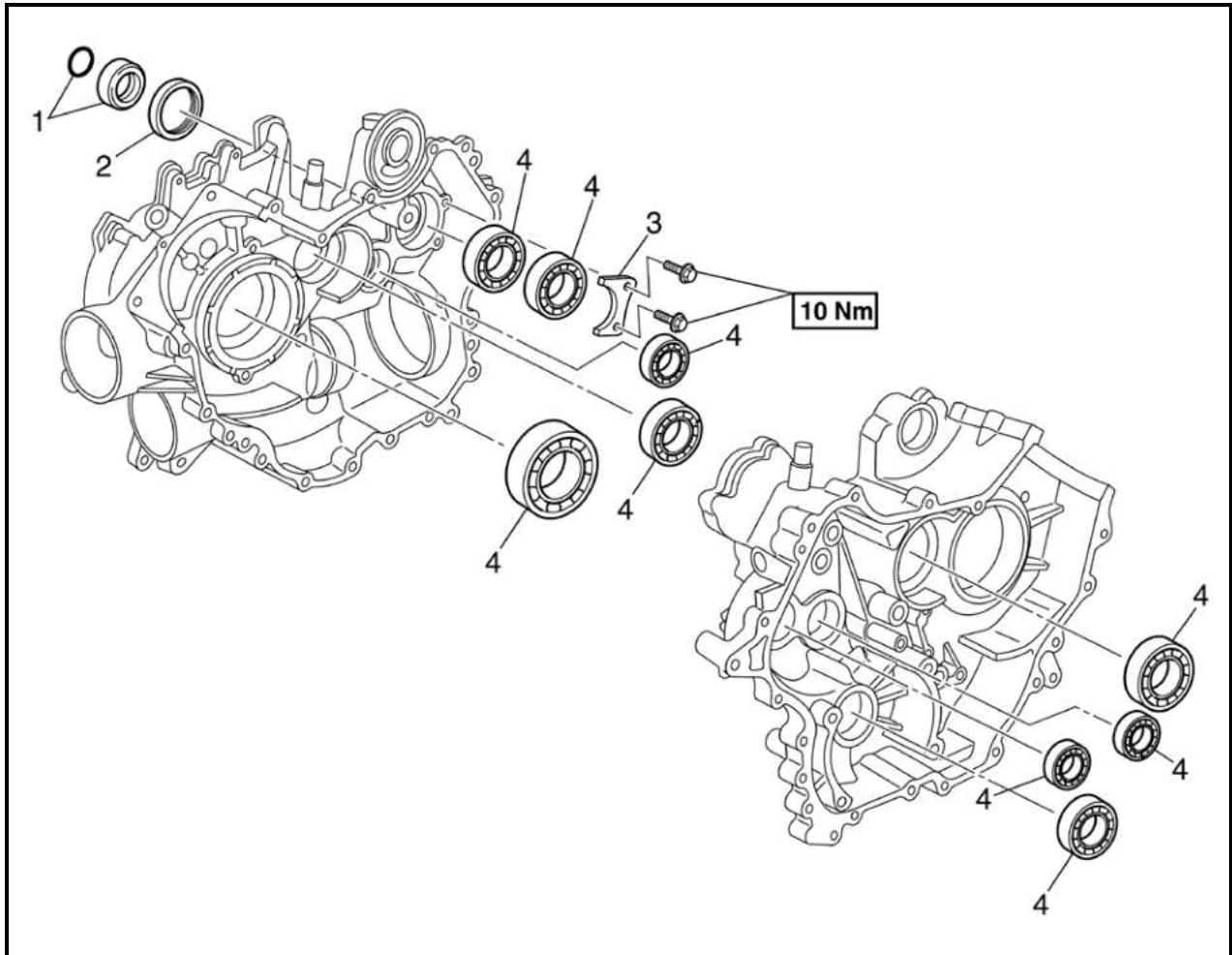

No.	Part Name	Qty	Remarks
	<b>Removing the crankcase bearings</b>		Remove the parts in the order listed.
	Crankshaft and oil pump		
	Transmission		
	Middle drive/driven shaft		
1	O-ring/collar	1/1	
2	Oil seal	1	
3	Bearing retainer	1	
4	Bearing	9	
			For installation, reverse the removal procedure.

## ENGINE

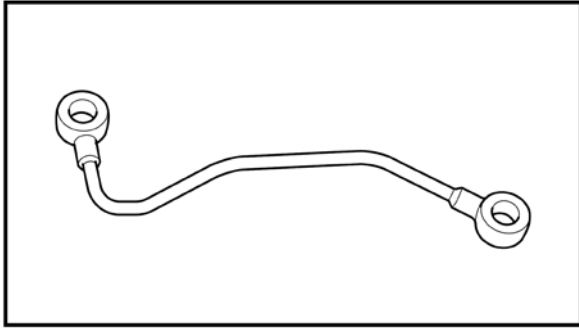

### 1. CHECK

#### 1). Checking the oil delivery pipe

- oil delivery pipe

Cracks/damage → Replace.

Clogged → Blow out with compressed air.

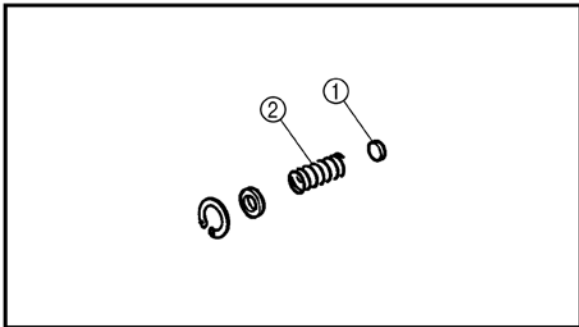

#### 2). Checking the relief valve

- relief valve ①

- spring ②

Damage/wear → Replace the defective part(s).

#### 3). Checking the crankcase

(1) Thoroughly wash the case halves in a mild solvent.

(2) Clean all the gasket mating surfaces and crankcase mating surfaces thoroughly

(3) check:

- crankcase

Cracks/damage → Replace.

- oil delivery passages

Clogged → Blow out with compressed air.

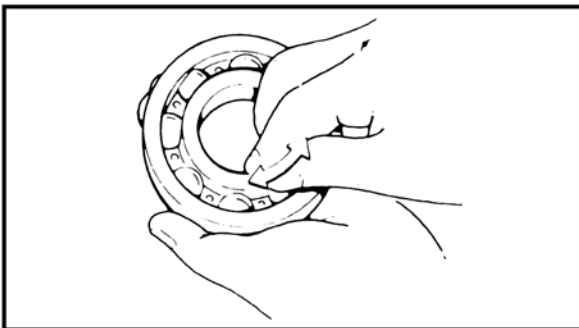

#### 4). Checking the bearings

(1) Check:

- bearings

Clean and lubricate, then rotate the inner race with a finger.

Roughness → Replace

# ENGINE

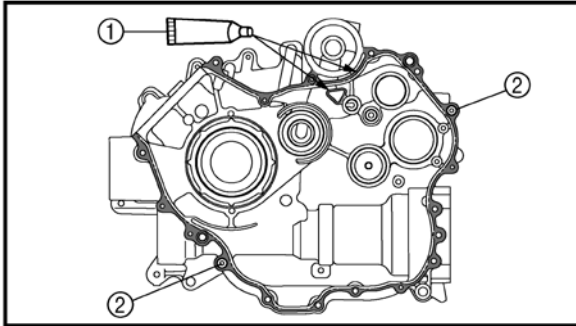

## 2、INSTALL

### 1). Assembling the crankcase

#### (1) Apply:

- sealant (Quick Gasket) ①  
(to the mating surfaces of both case halves)

#### (2) Install:

- dowel pins ②

#### (3) Fit the left crankcase onto the right case. Tap lightly on the case with a soft hammer

### **CAUTION:**

**Before installing and torque the crankcase holding bolts, be sure to check whether the transmission is functioning properly by manually rotating the shift drum in both directions.**

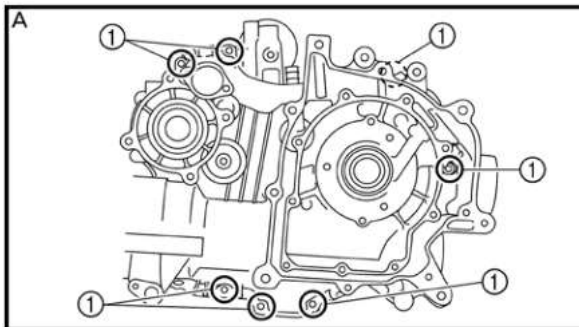

#### (4)Tighten:

- crankcase bolts ①, ② (10Nm)  
(follow the proper tightening sequence)
- crankcase bolts ③ (26Nm)  
(follow the proper tightening sequence)

A Left crankcase

B Right crankcase

### **NOTE:**

- Tighten the bolts in stages, using a crises cross pattern.
- Apply sealant (Quick Gasket) ④ to the thread of the bolt ② shown in the illustration

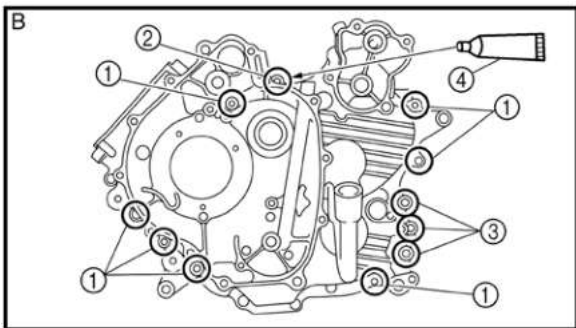

#### (5) Apply:

- 4-stroke engine oil  
(to the crank pin, bearing and oil delivery hole)

## ENGINE

---

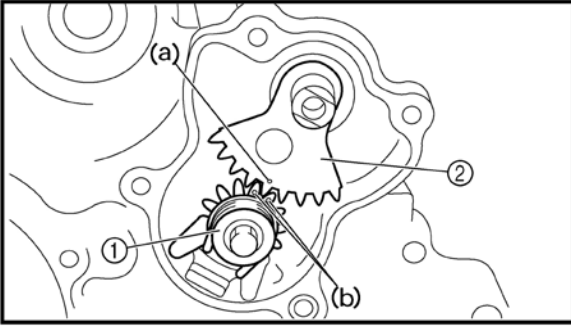

### 2). Installing the shift levers

- shift lever 2 assembly ① (14Nm)
- shift lever 1 ②

---

**NOTE:**

When installing the shift lever 1, align the punch mark (a) on the shift lever 1 with the punch marks (b) on the shift lever 2.

---

# ENGINE

## CRANKSHAFT AND OIL PUMP

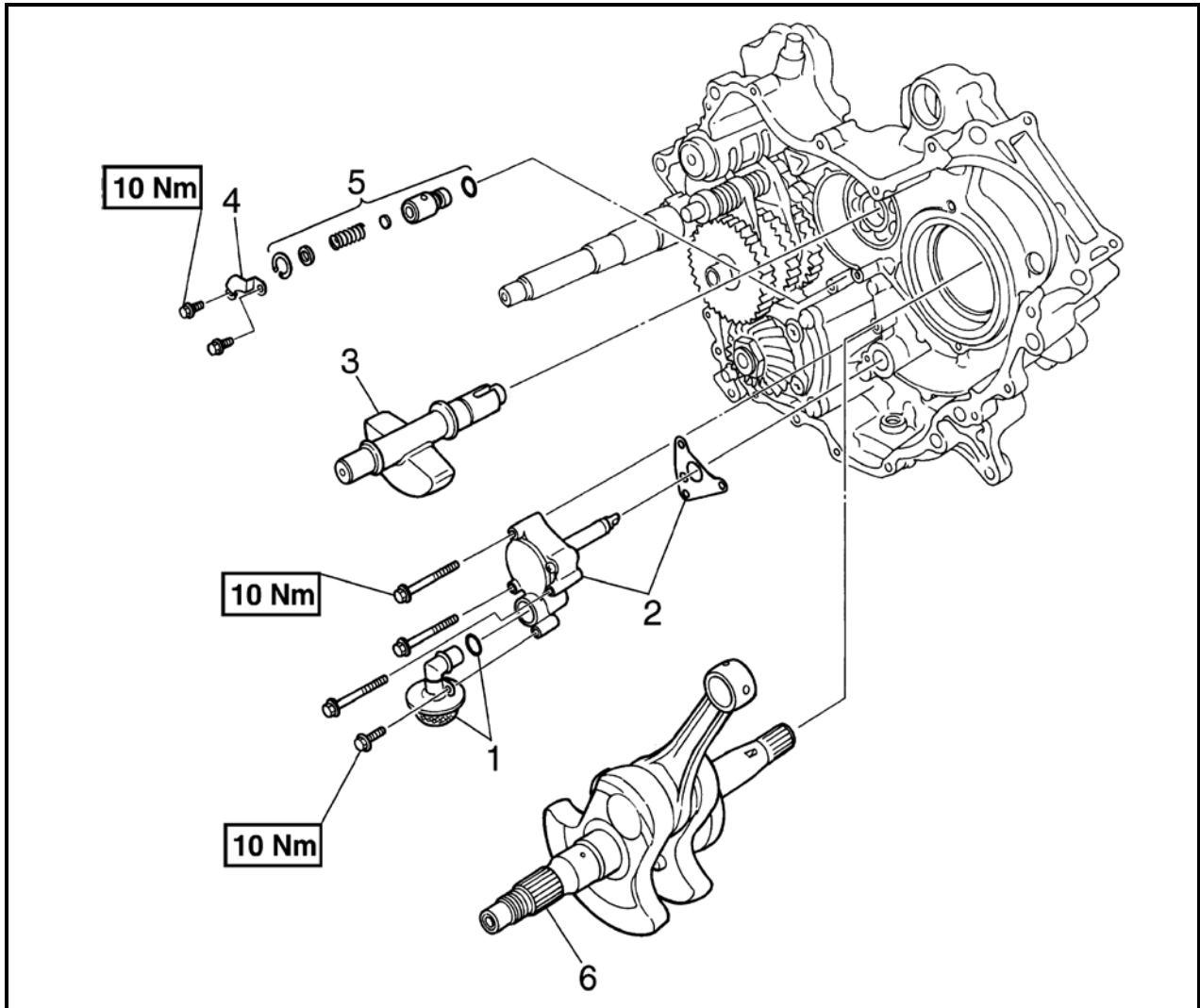

No.	Part Name	Qty	Remarks
	<b>Removing the crankshaft and oil pump</b>		Remove the parts in the order listed.
	Crankcase separation		
1	Oil strainer/O-ring	1/1	
2	Oil pump assembly/gasket	1/1	
3	Balancer	1	
4	Plate	1	
5	Relief valve assembly	1	
6	Crankshaft	1	
			For installation, reverse the removal procedure.



# ENGINE

## OIL PUMP

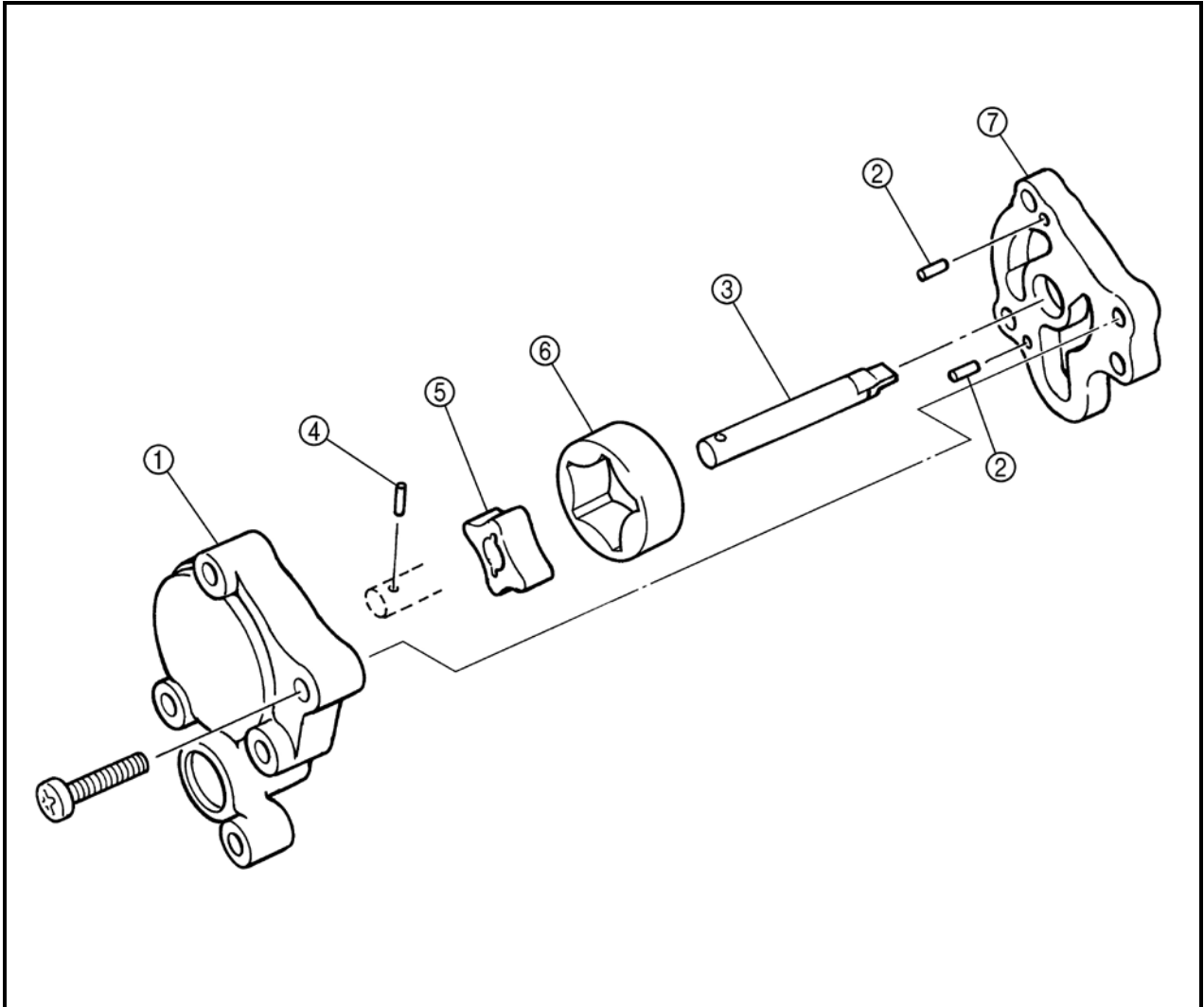

No.	Part Name	Qty	Remarks
	<b>Disassembling the oil pump</b>		Remove the parts in the order listed.
1	Rotor cover	1	
2	Pin	2	
3	Shaft	1	
4	Pin	1	
5	Inner rotor	1	
6	Outer rotor	1	
7	Oil pump housing	1	
			For assembly, reverse the disassembly procedure.

# ENGINE

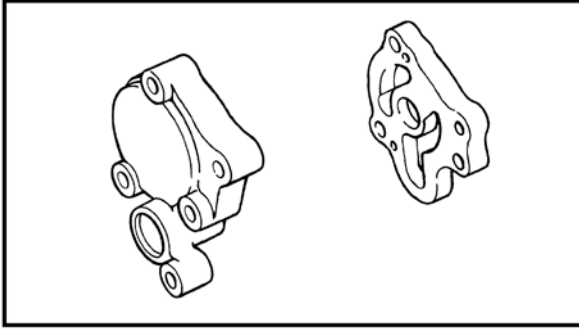

## 1、CHECK

### 1). Checking the oil pump

- rotor housing
- rotor cover
- Cracks/wear/damage → Replace.
- oil pump operation
- Unsmooth → Repeat steps #1 and #2 or replace the defective parts.

### 2). Checking the oil strainer

- oil strainer ①
- O-ring ②
- Damage → Replace.
- Contaminants → Clean with engine oil.

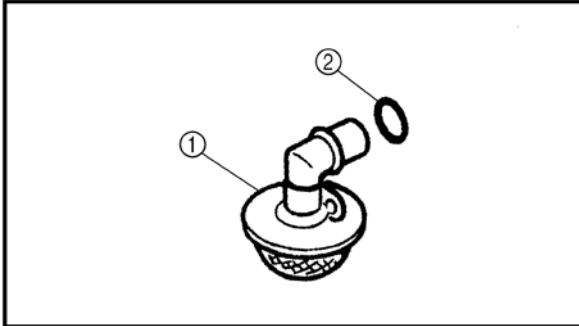

## 2、MEASURE

### 1). Measure the oil pump

- tip clearance(a)
- (between the inner rotor ① and the out rotor ②)
- ②)
- side clearance(b)
- (between the outer rotor ② and the pump housing ③)
- body clearance (c)
- (between the outer rotor ② and the pump housing ③)
- Out of specification → Replace the oil pump.

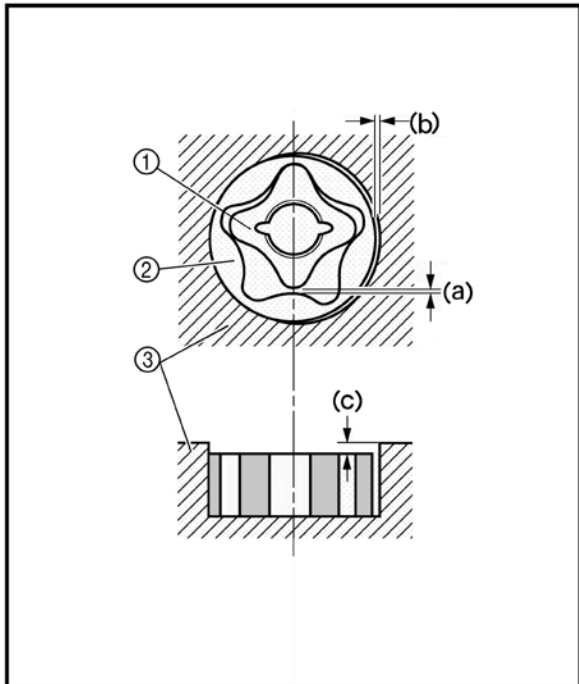

**Tip clearance Limit: 0.23 mm**

**Side clearance Limit: 0.17 mm**

**Body clearance Limit: 0.24 mm**

### 2). Measure the crankshaft

- crank width (A)
- Out of specification → Replace the crankshaft.

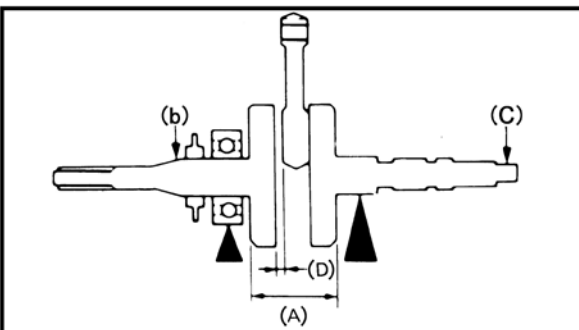

**Crank width**

**74.95 ~ 75.00 mm**

- side clearance (D)
- Out of specification → Replace the crankshaf

## ENGINE

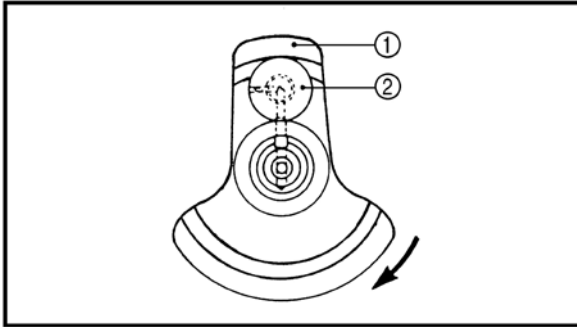

### Big end side clearance

Limit: 1.0 mm (0.0394 in)

- runout (b)(C)

Out of specification → Replace the crankshaft.

### Runout limit

(b): 0.03 mm (C): 0.03 mm

The crankshaft ① and the crank pin ② oil passages must be properly interconnected with a tolerance of less than 1 mm (0.04 in).

### CAUTION:

The buffer boss and woodruff key should be replaced when removed from the crankshaft.

### 3、INSTALL

- 1). Assembling the oil pump

- inner rotor
- outer rotor
- oil pump shaft

(with the recommended lubricant)

- 2). Installing the crankshaft and balancer

- crankshaft

### NOTE:

Hold the connecting rod at the Top Dead Center (TDC) with one hand while turning the nut of the installing tool with the other.

Operate the installing tool until the crankshaft bottoms against the bearing.

# ENGINE

## TRANSMISSION

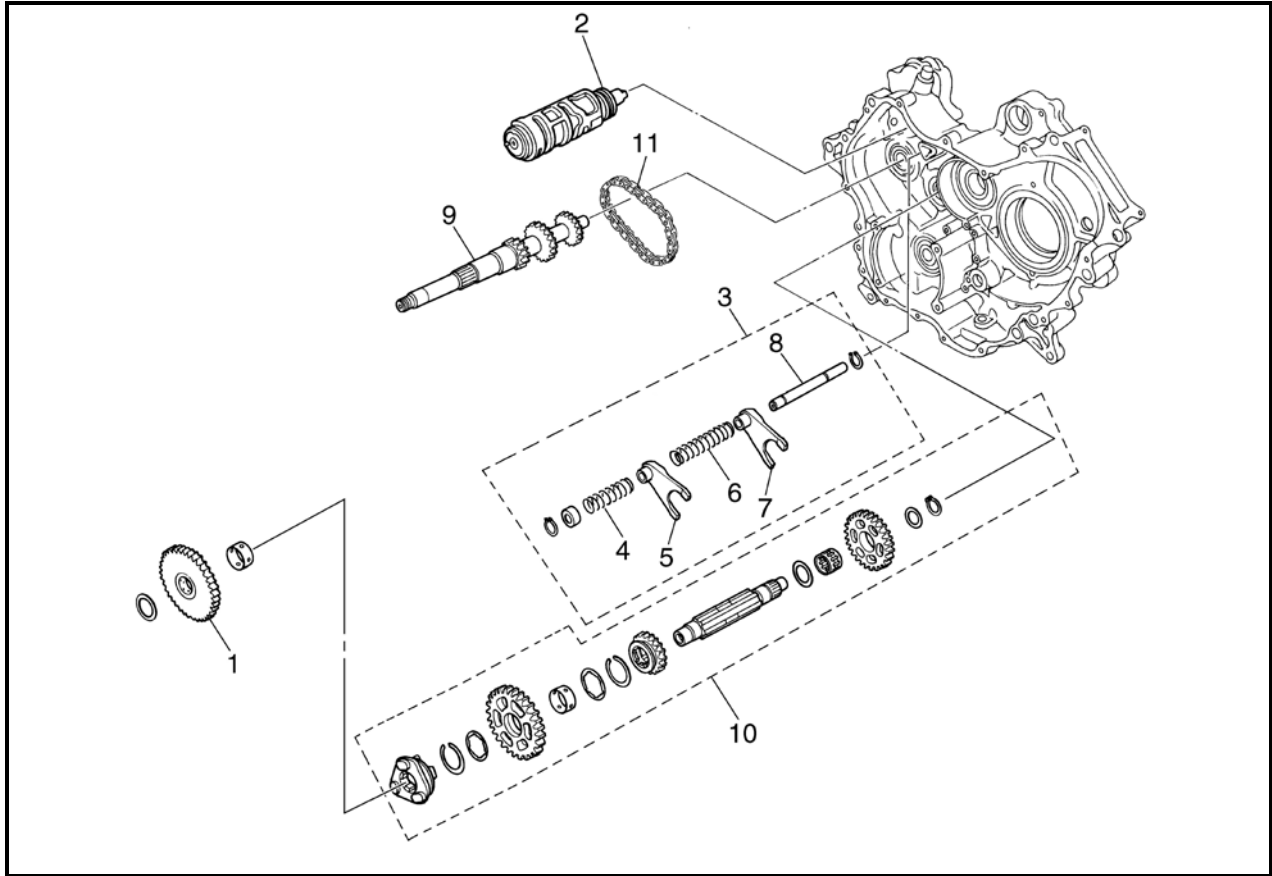

No.	Part Name	Qty	Remarks
	<b>Removing the transmission</b>		Remove the parts in the order listed.
	Crankcase separation		
	Middle driven gear		
1	Low wheel gear	1	
2	Shift drum	1	
3	Shift fork assembly	1	
4	Short spring	1	
5	Shift fork 1	1	
6	Long spring	1	
7	Shift fork 2	1	
8	Guide bar	1	
9	Secondary shaft	1	
10	Drive axle assembly	1	
11	Chain	1	
			For installation, reverse the removal procedure.

# ENGINE

## DRIVE AXLE ASSEMBLY

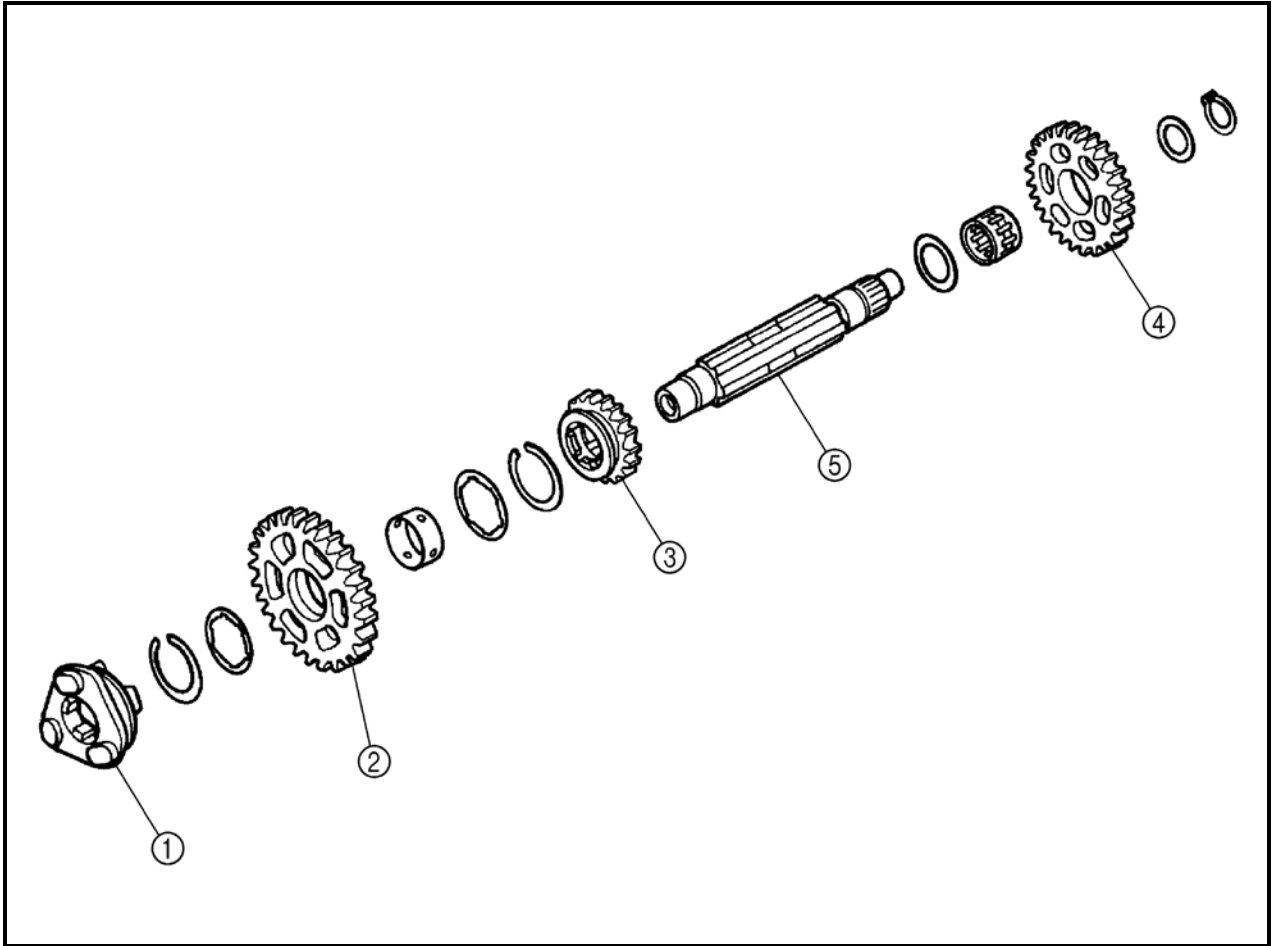

No.	Part Name	Qty	Remarks
	<b>Disassembling the drive axle</b>		
1	Clutch dog	1	Remove the parts in the order listed.  For assembly, reverse the disassembly procedure.
2	High wheel gear	1	
3	Middle drive gear	1	
4	Driven sprocket	1	
5	Drive axle	1	

## ENGINE

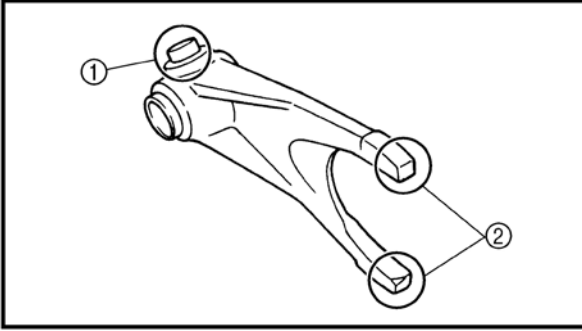

### 1. CHECK

#### 1). Checking the shift forks

- shift fork follower ①
- shift fork pawl ②

Scoring/bends/wear/damage → Replace.

- guide bar

Roll the guide bar on a flat surface.

Bends → Replace.

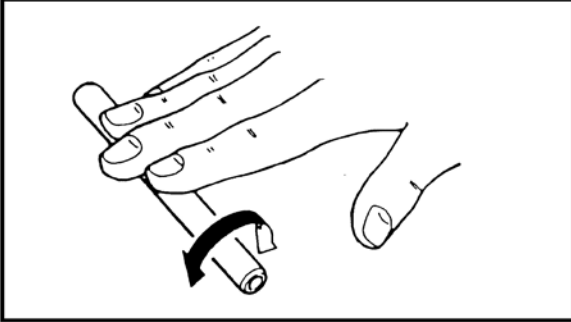

### **WARNING:**

*Do not attempt to straighten a bent guide bar.*

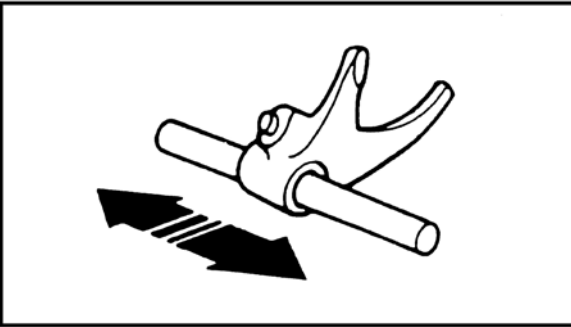

- shift fork movement  
(on the guide bar)

Unsmooth operation → Replace the shift fork and the guide bar.

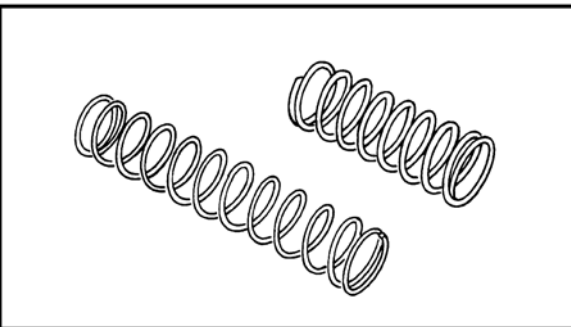

- springs

Cracks/damage → Replace.

#### 2). Checking the shift drum

- shift drum grooves

Scratches/wear/damage → Replace.

## ENGINE

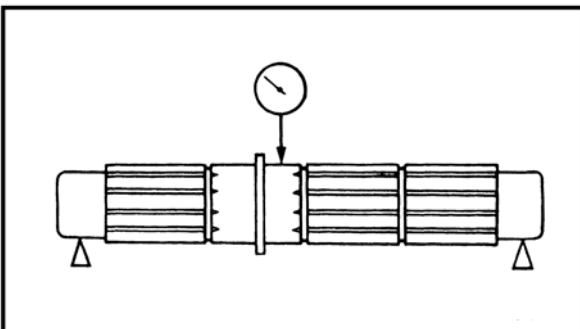
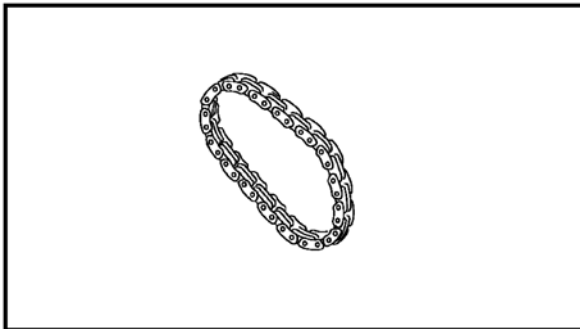
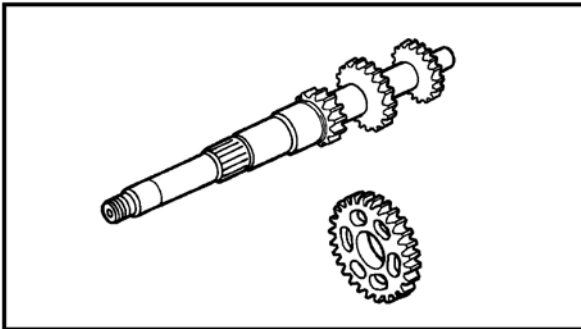
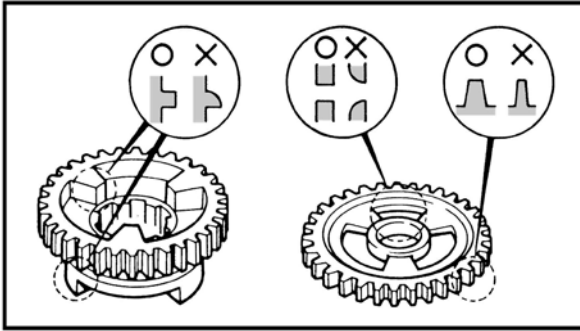

3). Checking the high wheel gear and middle drive gear

- gear teeth  
Blue discoloration/pitting/wear → Replace.
- mated dogs  
Rounded edges/cracks/missing portions  
→ Replace.
- gear movement  
Unsmooth → Repeat steps #1 or replace the defective parts.
- circlip  
Bends/looseness/damage → Replace.

4). Checking the secondary shaft and driven sprocket

- gear teeth  
Blue discoloration/pitting/wear → Replace.
- gear movement  
Unsmooth → Repeat steps #1 or replace the defective parts.
- circlip  
Bends/looseness/damage → Replace.

5). Checking the chain

- chain  
Cracks/shift → Replace the chain, secondary shaft and driven sprocket as a set.

### 2. Measure:

- axle runout  
Use a centering device and a dial gauge.  
Out of specification → Replace the bent axle.

**Drive axle runout limit**

**0.06 mm**

## ENGINE

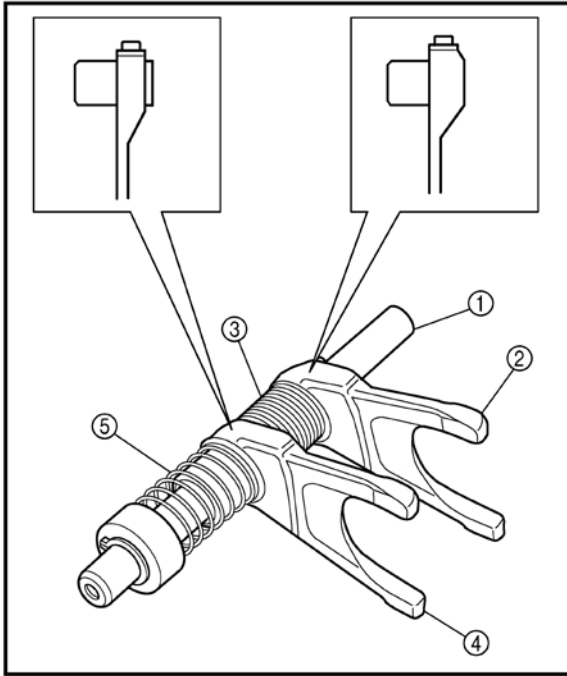

### 3、INSTALL

#### 1). Assembling the shift fork

- guide bar ①
- shift fork 2 ②
- long spring ③
- shift fork 1 ④
- short spring ⑤

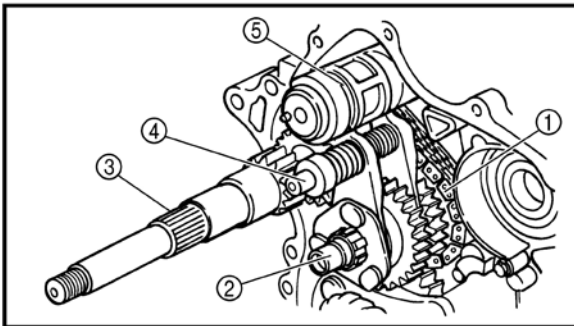

#### 2). Installing the transmission

- chain ①
- drive axle assembly ②
- secondary shaft ③
- shift fork assembly ④
- shift drum ⑤
- low wheel gear

#### **NOTE:**

- Oil each gear and bearing thoroughly.
- Before assembling the crankcase, be sure hat the transmission is in neutral and that the gears turn freely.



# ENGINE

## MIDDLE GEAR

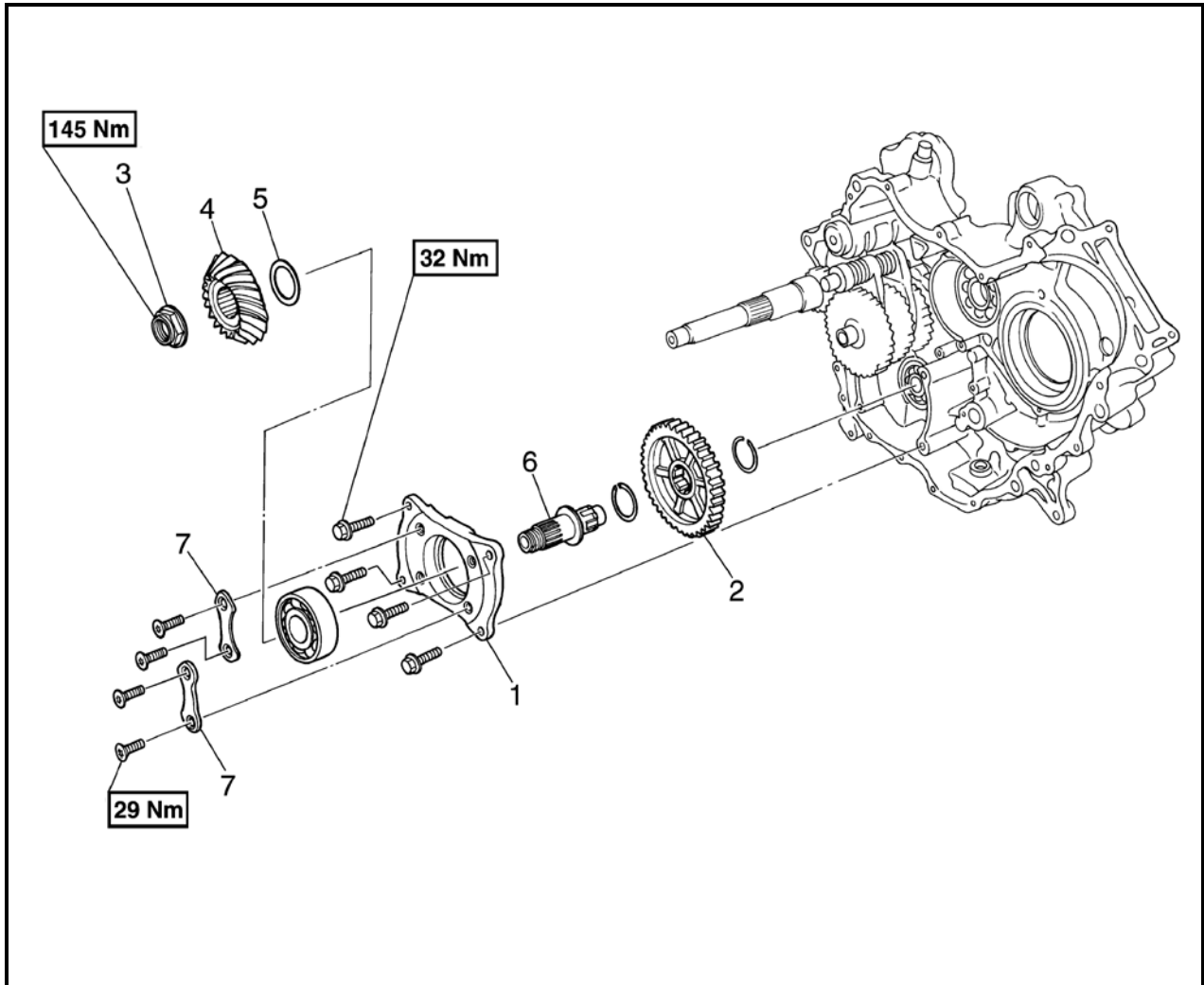

No.	Part Name	Qty	Remarks
	<b>Removing the middle drive shaft</b>		Remove the parts in the order listed.  For assembly, reverse the disassembly procedure.
	Crankcase separation		
1	Bearing housing	1	
2	Middle drive gear	1	
3	Nut	1	
4	Middle drive pinion gear	1	
5	Shim	1	
6	Middle drive shaft	1	
7	Bearing retainer	2	

# ENGINE

## MIDDLE DRIVEN SHAFT

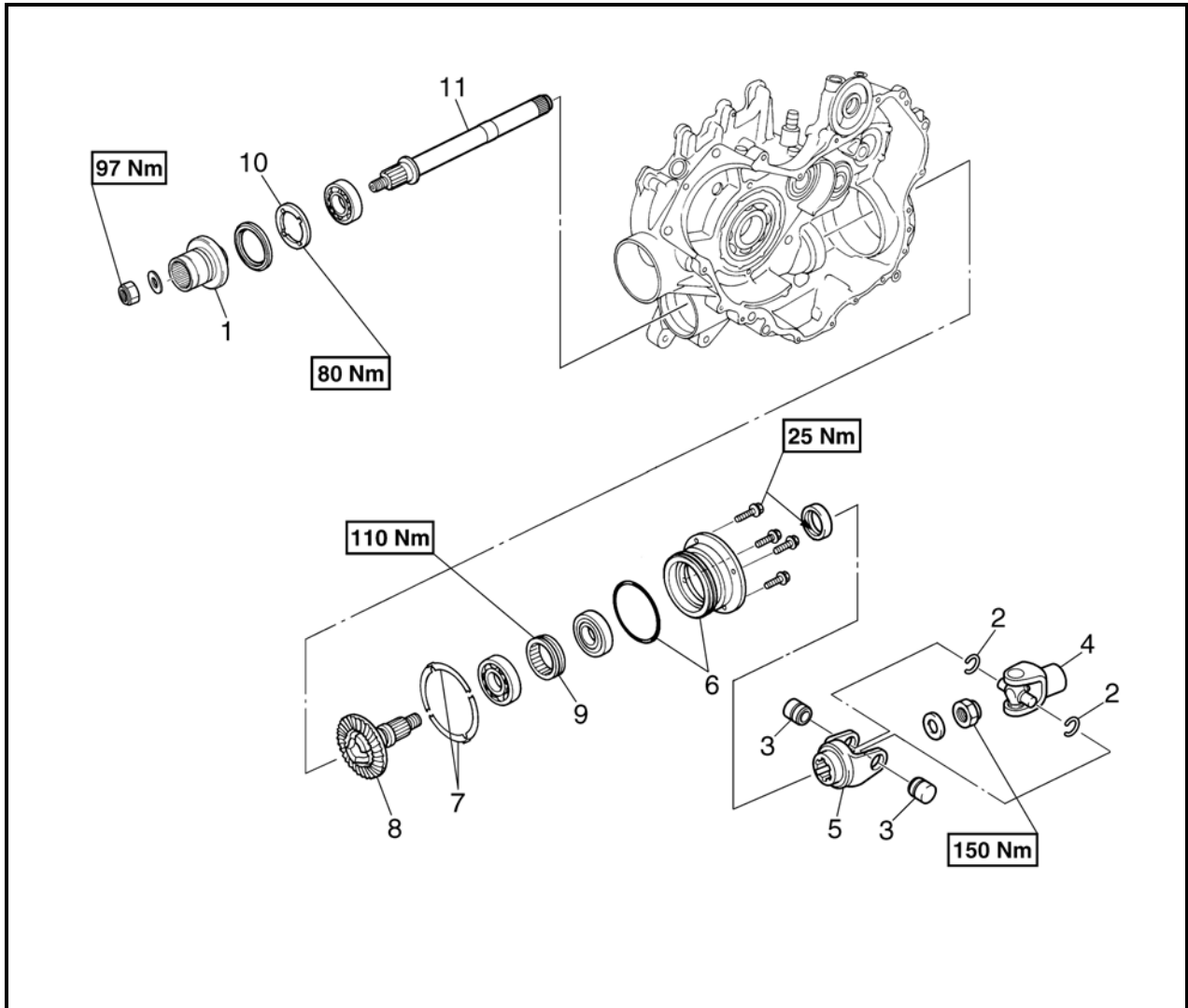

No.	Part Name	Qty	Remarks
	<b>Removing the middle drive shaft</b>		Remove the parts in the order listed.
	Crankcase separation		
1	Drive shaft coupling	1	
2	Circlip	2	
3	Bearing	2	
4	Universal joint	1	
5	Universal joint yoke	1	
6	Bearing housing/O-ring	1/1	
7	Shim	1	
8	Middle driven pinion gear	1	
			For installation, reverse the removal procedure.

# ENGINE

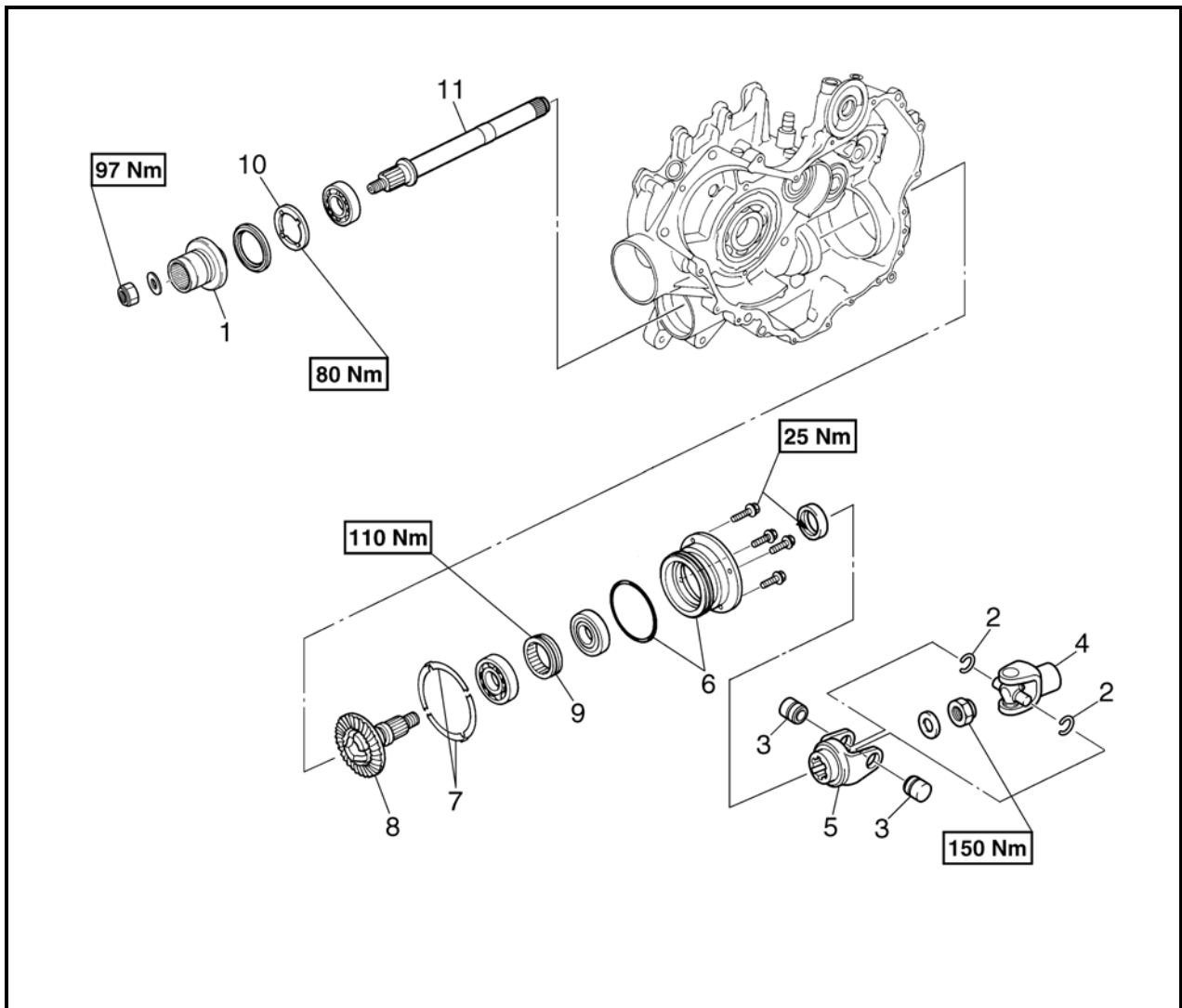

No.	Part Name	Qty	Remarks
9	Bearing retainer	1	For installation, reverse the removal procedure.
10	Bearing retainer	1	
11	Middle driven shaft	1	

# ENGINE

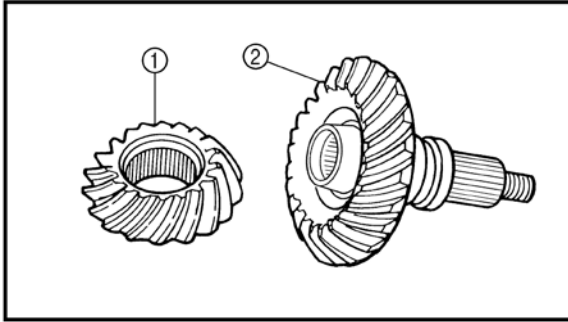

## 1、CHECK

### 1). Checking the pinion gears

- gear teeth (drive pinion gear) ①
- gear teeth (driven pinion gear) ②  
Pitting/galling/wear → Replace.
- O-ring  
Damage → Replace.
- bearings  
Pitting/damage → Replace.
- universal joint movement  
Roughness → Replace universal joint.

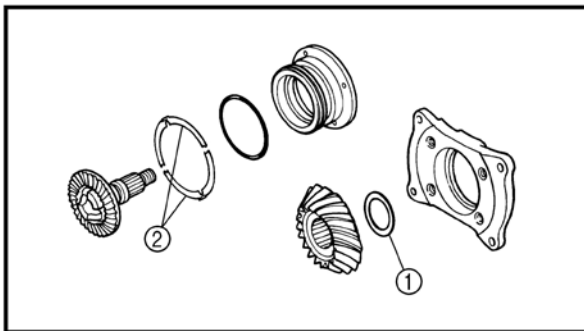

### 2). Selecting the middle drive and driven gear shims

When the drive and driven gear, bearing housing assembly and/or crankcase replaced, be sure to adjust the gear shims ① and ②.

- middle drive gear shim ①
- middle driven gear shim ②

## 2、MEASURE

- gear lash

### Middle gear lash

0.1 ~ 0.3 mm

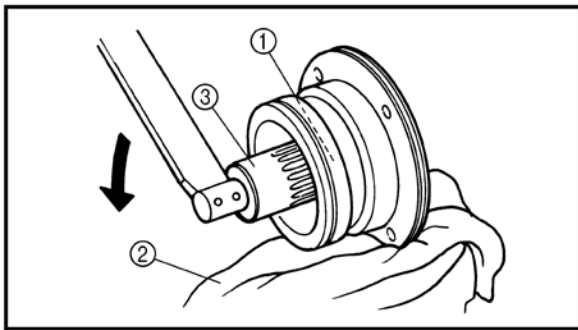

- Temporary install the left crankcase.
- Wrap a rag ① around a screwdriver ②, and then insert it into the installation hole ③ of the right crankcase speed sensor to hold the middle driven gear.
- Attach the gear lash measurement tool ④ and dial gauge ⑤.
  - 6.7 mm (0.26 in)
- Measure the gear lash while rotating the middle driven shaft back and forth.

### **NOTE:**

**Measure the gear lash at 4 positions. Rotate the middle driven gear 90° each time. If the gear lash is incorrect, adjust the gear lash by middle driven pinion gear shims and/or middle drive pinion gear shim(s).**

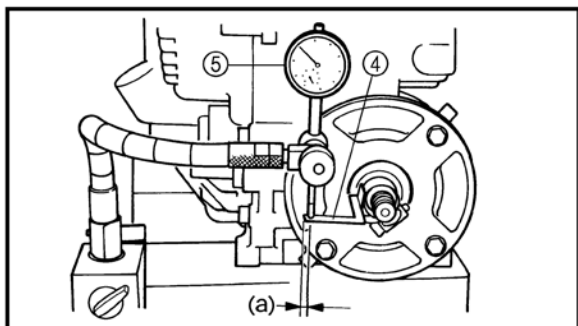

## ENGINE

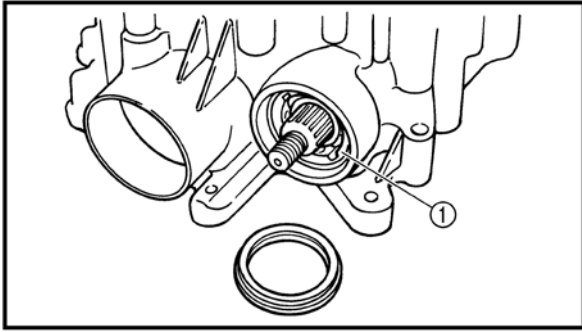

### 3、INSTALL

- 1). Installing the middle driven shaft
  - bearing retainer ①

**Bearing retainer**  
80 Nm

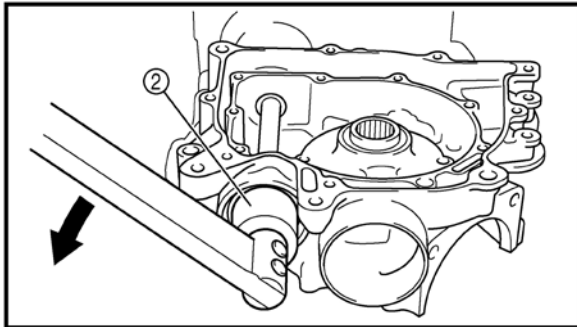

#### **NOTE:**

Attach the ring nut wrench ②.

#### **CAUTION:**

The middle driven shaft bearing retainer has left-handed threads. To tighten the retainer, turn it counterclockwise.

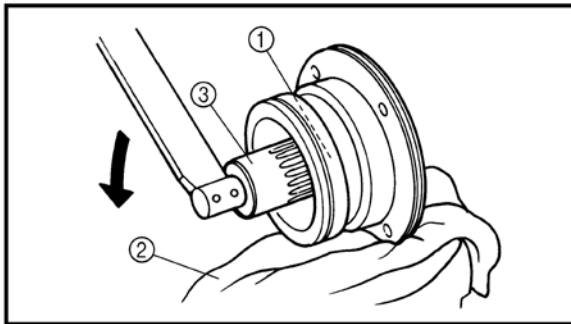

- bearing retainer ①

- a. Place a rag ② in the vise.
- b. Secure the bearing housing edge in the vise.
- c. Attach the bearing retainer wrench ③.
- d. Tighten the bearing retainer.

#### **CAUTION:**

The middle driven shaft bearing retainer has left-handed threads. To tighten the retainer, turn it counterclockwise.

**Bearing retainer**  
110Nm

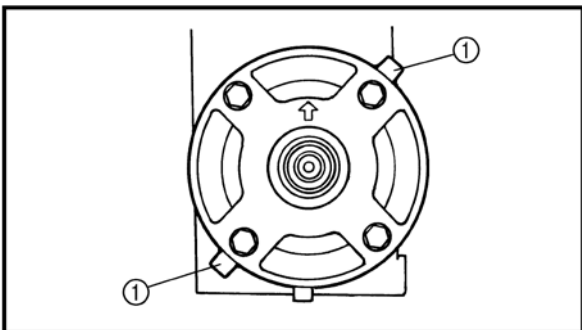

- shims ①
- bearing housing

#### **NOTE:**

Install the shims so that the tabs are positioned as shown in the illustration.

## ENGINE

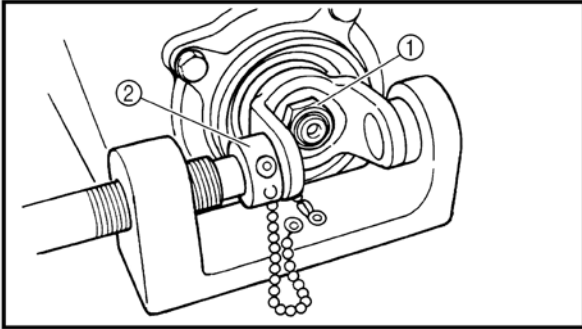

- universal joint yoke
- washer
- nut ①

**NOTE:**

Use the universal joint holder ② to hold the yoke.

**Universal joint yoke nut**

**150 Nm**

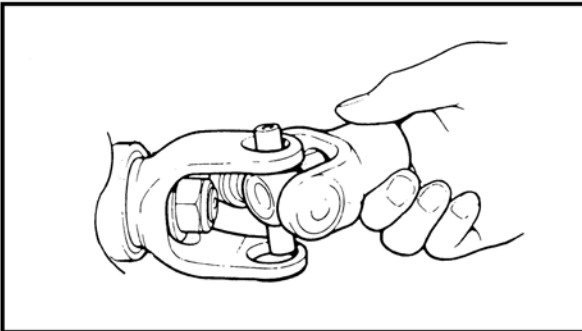

- universal joint.
- a. Install the opposite yoke into the universal joint.
- b. Apply wheel bearing grease to the bearings.

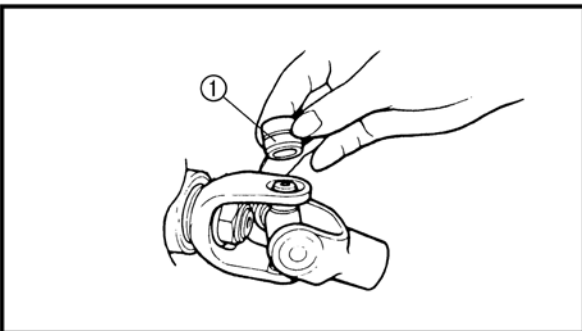

- c. Install the bearing ① onto the yoke.

**CAUTION:**

Check each bearing. The needles can easily fall out of their races. Slide the yoke back and forth on the bearings; the yoke will not go all the way onto a bearing if a needle is out of place.

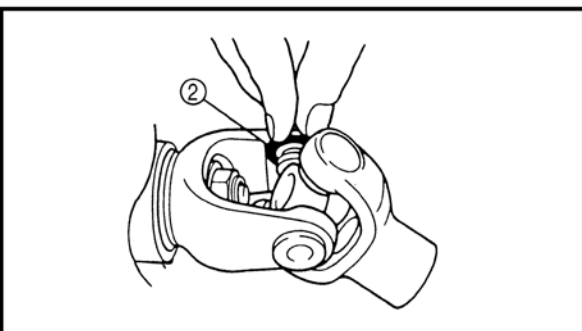

- d. Press each bearing into the universal joint using a suitable socket.

**NOTE:**

The bearing must be inserted far enough into the universal joint so that the circlip can be installed.

- e. Install the circlip ② into the groove of each bearing.

## ENGINE

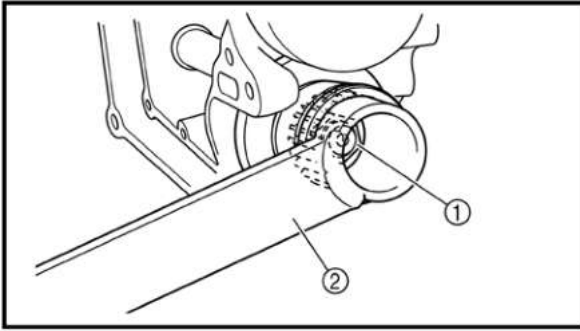

- drive shaft coupling
- washer
- nut (97Nm)

**NOTE:**

Use the coupling gear/middle shaft tool (2) to hold the drive shaft coupling.

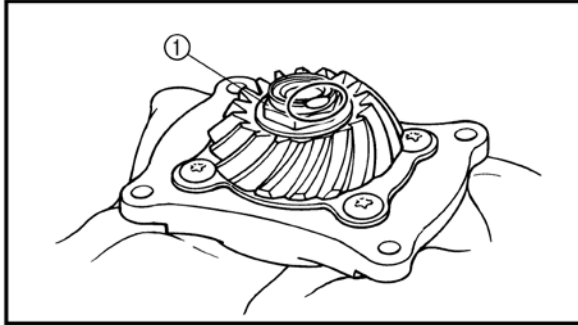

2). Installing the middle drive shaft

(1) Tighten:

- middle drive pinion gear nut (1) (145Nm)

**NOTE:**

Secure the middle drive shaft in the vise with a clean rag.

(2) Lock the threads with a drift punch.

# HS750UTV/HS550UTV WIRING DIAGRAM

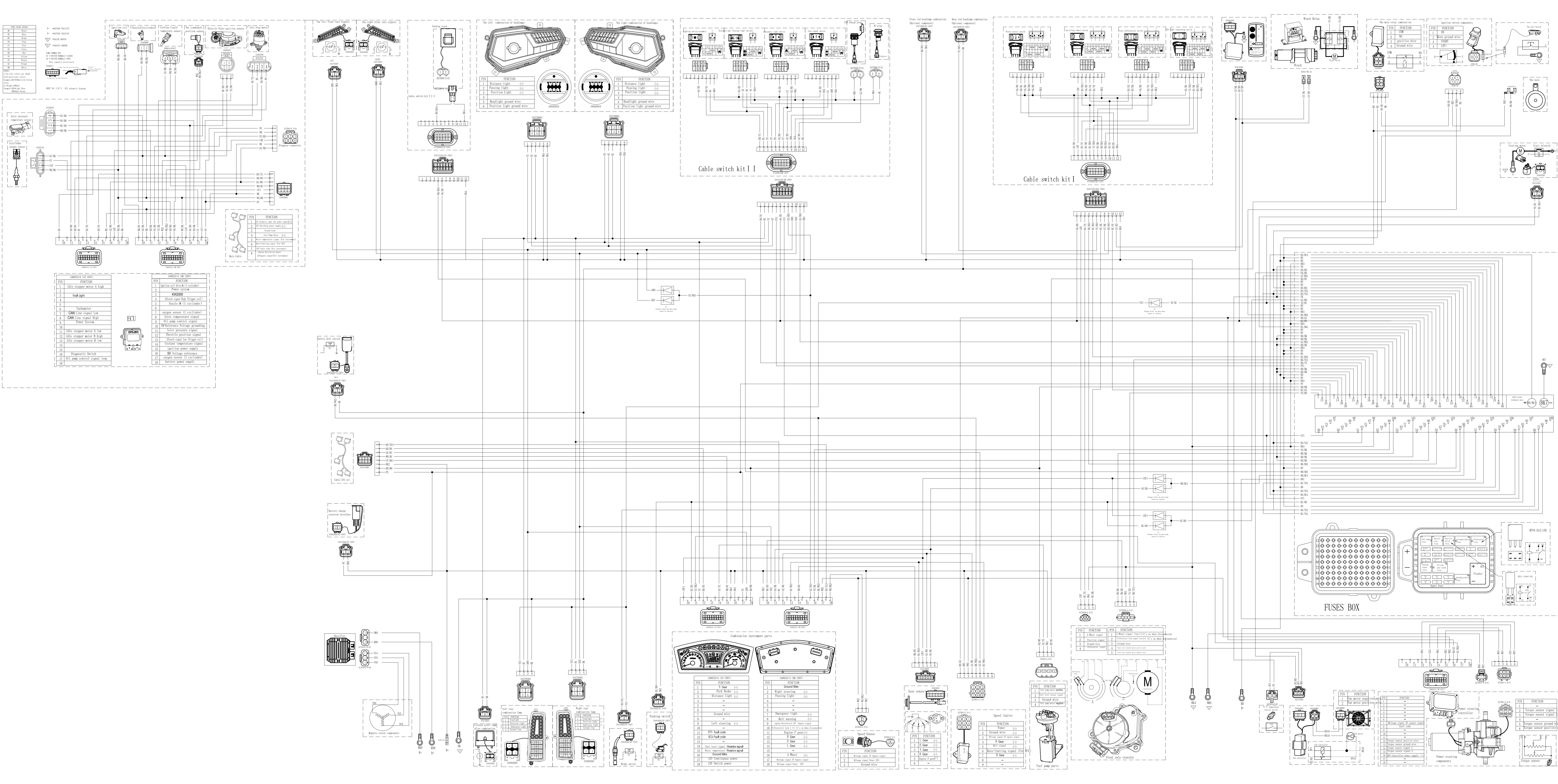





## **SERVICE MANUAL**

Published by Chongqing Huansong Science  
And Technology Industrial Co.,Ltd