

4'5' & 6' ROTARY TILLER

OWNER'S OPERATION & PARTS MANUAL

For additional information, please see us at
www.badboymowers.com

Bad Boy, Inc.
102 Industrial Drive
Batesville, Arkansas 72501

TO THE DEALER

Assembly, initial lubrication, and verification of proper installation of this product is the responsibility of the Bad Boy dealer. Be familiar with the safety rules and instructions found in this manual. Ensure all items on the Dealer's Pre-Delivery and Delivery Checklists in this manual are completed before releasing the unit to the new owner.

TO THE OWNER

Note: Anyone who operates your Bad Boy implement must first read this owners manual. Although this implement has been engineered with safety and reliability as the foremost concerns, there is no substitute for an informed and cautious operator. This manual should be viewed as a part of the equipment itself. If this manual is lost, destroyed, or otherwise rendered unreadable, obtain a duplicate immediately. A duplicate can be obtained online at www.badboymowers.com.

As with all machinery, this implement requires periodic maintenance and should be kept free of debris buildup. Proper care will ensure many years of dependable service. Replacement parts should only be obtained from your Bad Boy dealer or through the website referenced above.

Failure to utilize approved parts can be dangerous and will void the warranty.

LEA EL INSTRUCTIVO!

Si no lee Ingles, pida ayuda a alguien que si lo lea para que le traduzca las medidas de seguridad.

Three terms are utilized throughout this manual and are present on the Implement safety decals:

DANGER, WARNING, and CAUTION.

DANGER: Indicates a hazardous situation that, if not avoided will result in death or serious injury.

WARNING: Indicates a hazardous situation that, if not avoided, could result in death or serious injury.

CAUTION: Indicates a hazardous situation that, if not avoided, could result in minor or moderate injury.

In order to better draw attention to these important safety messages, the above terms are accompanied with the following pictorial:



TABLE OF CONTENTS

SPECIFICATIONS	4
SAFETY RULES	5
GENERAL INFORMATION.....	8
OPERATION	8
PTO SIZING/ OPERATING.....	9
OWNER SERVICE	11
PARTS.....	12
PRODUCT WARRANTY	14

SPECIFICATIONS	4' 5' & 6'
Category	4' 5' & 6' Bab boy Implement
Lift Attachment Brackets	1/2" Solid Welded
Warranty	1 Year Limited
Total Width 4' 5' & 6'	53" / 65" / 77"
Overall Height 4' 5' & 6'	37"
Length 4' 5' & 6'	26.5"
Weight 4' 5' & 6'	658lbs / 698lbs / 738lbs
Rotor Bar 4' 5' & 6'	46.5" / 58.5" / 70.5"
3-Point Hitch	Category 1& 2
Tractor HP Range	25hp to 45hp
Maximum Tilling Depth	6.5"
Drive Type	Gearbox
Number of Tines / Flanges	36 /6 - 42/7 - 54/9
Number of Tines per Flange	6
Tractor PTO Speed	540 RPM
PTO Driveline Protection	Slip Clutch
Till Direction	Forward
Adjustable Skids	Yes
Quick Hitch Compatible	Yes

SAFETY RULES

Note: (Safety instructions are important!! While these instructions may seem lengthy or redundant, they are presented for your safety)

TRAINING

- Almost all accidents arising from the use of equipment such as this that has resulted in injury or death would have been avoided had instructions such as these been adhered to.
- If you do not understand any part of this manual, contact your dealer for assistance.
- Dangerous situations can arise quickly. Know your controls and how to stop the engine and attachment in an emergency. Fractions of a second can be extremely important.
- Do not allow anyone to operate the equipment without first requiring them to read this manual and giving proper instruction.
- Never allow children (< 16 years of age) or untrained persons to operate the equipment.

PREPARATION

- Check that all hardware is properly installed.
- Wear sturdy, rough-soled work shoes and protective equipment for eyes, hair, hands, hearing, and head. Wear a respirator or filter mask where appropriate.
- Make sure the implement is properly secured, adjusted, lubricated, and in good operating condition.
- Tractor must be equipped with Roll-Over Protective Structure (ROPS) or ROPS cab and seat belt. ALWAYS keep seat belt securely fastened. Falling off the tractor can, and does, result in death. Keep foldable ROPS system in 'locked up' position at all times.
- Make sure all safety decals are installed and free from damage. Replace if damaged.
- A minimum of 20% of tractor and equipment weight must be on the tractor front wheels when attachments are in transport position. Without this weight, front tractor wheels could raise up resulting in loss of steering. The weight may be attained with front wheel weights, ballast in tires or front tractor weights. Weigh the tractor and equipment, do not estimate.
- Check tractor and equipment clearance. when in transport position some equipment with rippers, chain guards, or skids may get into tires if in a low hanging position. Always check tractor to equipment clearance before transporting.

OPERATION

- Do not operate or transport equipment while under the influence of alcohol or drugs.
- Operate only in daylight or good artificial light.
- Keep hands, feet, hair, and clothing away from equipment while engine is running. Stay clear of all moving parts.
- Always comply with all state and local lighting and marking requirements.
- **NEVER ALLOW RIDERS ON POWER UNIT OR IMPLEMENT!**
- Always sit in the tractor seat when operating controls or starting engine. Securely fasten seat belt, place transmission in neutral, engage brake, and ensure all other controls are disengaged before starting tractor engine.
- Look down and to the rear and make sure area is clear of people, animals, property, or foreign objects before operating in reverse. Children often do not understand the severity of the potential danger. A major portion of implement accidents involve children being ran over during reverse operation of the implement.
- Do not operate or transport on steep slopes.
- Do not stop, start, or change directions suddenly on slopes.
- Use extreme care and reduce ground speed on slopes and rough terrain.
- Watch for hidden hazards on the terrain during operation.
- Stop tractor unit and equipment immediately upon striking an obstruction. Turn off engine, remove key, inspect, and repair any damage before operation resumes.
- Leak down or failure of mechanical or hydraulic system can cause equipment to drop.
- Make certain all movement of equipment components has stopped before exiting the tractor.

- Do not allow bystanders in the area when operating, attaching, removing, assembling, or servicing equipment.
- Keep all persons away from operator control area while performing adjustments, service, or maintenance.
- Do not modify or alter (or permit anyone else to modify or alter) the equipment or any of its components in any way.
- Always wear relatively tight and belted clothing to avoid getting caught in moving parts. Wear sturdy, rough-soled work shoes and protective equipment for eyes, hair, hands, hearing, and head.
- Make certain all movement of equipment components has stopped before approaching for service.

STORAGE

- Keep children and bystanders away from storage area.

CHILDREN

Extremely tragic accidents can, and do, occur if the operator is not continually alert to the presence of children. Children are often attracted to machinery. NEVER assume that children will remain where you last saw them.

- Never allow children to operate the equipment (<16 years of age).
- Use extra care when approaching blind corners, shrubs, trees, or other objects that may block your view of a child.

GENERAL INFORMATION

WARNING

The purpose of this manual is to assist you in operating and maintaining your implement. Read it carefully. It furnishes information and instructions that will help you achieve years of dependable performance. These instructions are the product of extensive field experience, engineering data, accident reports, and statistical data. Although some information may be general in nature due to unknown and varying operating conditions, through experience and adherence to these instructions, you should be able to develop sound operating procedures suitable to your particular situation.

The illustrations and data used in this manual were current at the time of printing, but due to possible running changes, your machine may vary slightly in detail. Bad Boy Implements reserves the right to redesign and change the machines as necessary without notification.

Throughout this manual, references are made to right and left sides of the equipment. These directions are determined by standing behind the equipment.

OPERATION

The operator is responsible for the safe operation of the implement. The operator must be properly trained. Operators should be familiar with the implement, the tractor utilized, and all safety practices before starting operation.

CHECK DRIVELINE MAXIMUM LENGTH

Refer to Figure 2

Make sure driveline collapsible length is acceptable. If needed, refer to "Attaching To Tractor".

The driveline maximum allowable length must, when fully extended, have a minimum overlap of the profile tubes by not less than 1/3 the free length with both inner and outer profile tubes being of equal length.

1. Apply multi-purpose grease to the inside of the outer shaft and reassemble the driveline.
2. Assemble the two driveline profiles together with just 1/3 overlapping of the profile tubes as shown below. Once assembled, measure and record the maximum allowable length for future reference.

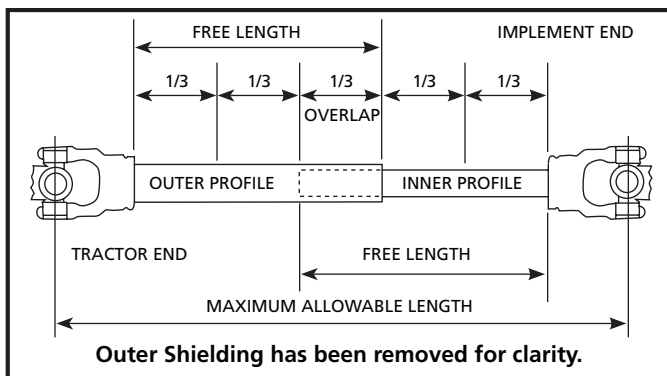

Driveline Maximum Extended Length

Figure 2

3. Attach inner driveline yoke to the tiller gearbox shaft. Attach outer driveline yoke to the tractor's PTO shaft.
4. Move yoke ends of driveline back and forth to insure they are secured to the tractor and tiller shafts. Reattach any end that is loose.

IMPORTANT: Small chains are supplied with the driveline. They must be attached to the inner and outer driveline shields and to the tiller and tractor to restrict shield rotation.

5. Hook driveline safety chain on the tractor end of driveline to tiller frame. Re-latch safety chain to the driveline shield.
6. Hook driveline safety chain on the Rotary Tiller end of driveline to the tiller frame. Re-latch safety chain to driveline shield.

7. Start tractor and raise Rotary Tiller just enough to remove support blocks.
8. Slowly engage tractor hydraulic 3-point control lever to lower the tiller while checking for sufficient drawbar clearance. Move drawbar ahead, aside or remove if required.
9. Raise and lower implement to find maximum extended driveline length. Check to make certain the driveline does not exceed maximum allowable length recorded in step 2.
10. If needed, set tractor 3-point lift height to stop driveline from exceeding maximum allowable length.
11. Continue with "Check Driveline Maximum Angle" below.

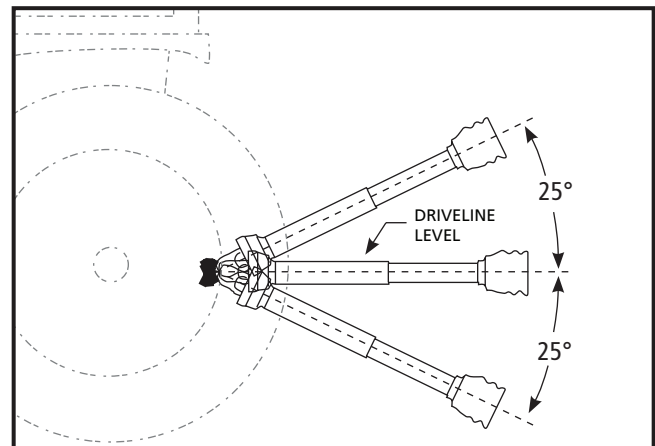

Check Driveline Maximum Angle

Figure 3

CHECK DRIVELINE MAXIMUM ANGLE

Refer to Figure 3

IMPORTANT: To avoid premature driveline breakdown, do not exceed an angle of 25° up or down with the driveline while driveline is rotating. If needed, set tractor 3-point lift lever to limit driveline angle at a maximum of 25° up.

1. Raise and lower implement to find maximum driveline angle. Check to make certain the driveline does not exceed 25° up or down.
2. If needed, set tractor 3-point lift height to keep driveline from exceeding 25° up.

OPERATING INSTRUCTIONS

1. Before each use perform the maintenance described in maintenance section on this page.
2. Read, understand, and follow the safety information on training, preparation, starting and stopping, operation, transportation, maintenance and storage at the beginning of this manual (pages 4 thru 7).
3. With the rotary tiller positioned on level ground, adjust the tractor lift arms so that when lifted, the rotor bar remains parallel to the ground.
4. With the rotary tiller attached to the tractor, raise and support the tiller with suitable blocks. Adjust the skids, located on the sides of the tiller. The adjustment bolts for both right and left sides should be positioned in the same adjustment hole. This allows the tiller to till the same depth on each side. Adjust the back plate, with regulating chain, until the desired mulching effect is found.

NOTE: Never attempt to adjust the rotary tiller while the tractor is running.

5. Raise the tiller and remove the blocks. Lower the tiller to the ground.
6. With the tractor at idle RPM and the tiller lifted off of the ground, engage PTO and slowly advance throttle to 540 PTO RPM.

NOTE: Rotary tiller is designed to run at 540 PTO RPM only.

7. Select a low gear for the tractor and begin to move forward. Tractor ground speed is to be controlled by gear selection only and not engine speed. As the tractor moves forward, slowly lower the tiller down. Allow the tiller tines to gradually engage the ground.

NOTE: Do not allow the tractor engine or rotary tiller to bog down or stall. This causes undue wear and tear on the tiller and tractor. If this continues to happen reduce ground speed and raise tilling depth of rotary tiller. Never attempt to remove objects from the rotor bar until the tractor has been shut down and the tiller tines have completely stopped.



Never travel at a fast ground speed while using the tiller, this could damage it. Never attempt to turn the tractor or travel in reverse with the PTO engaged and the tiller in the ground. Always raise the tiller out of the ground when backing up or attempting to turn. Failure to do so may cause damage to the tiller.

8. After each use clean all debris from the tiller tines. Replace any missing or illegible safety decals. Inspect for any damaged or worn parts and replace before next use. Store rotary tiller in a dry environment.

MAINTENANCE

1. Periodically check and maintain proper gear oil level.
2. Every 8 hours, (1) grease "out-board hub", (2) PTO shaft universal joints, (3) PTO shaft safety shield and (4) PTO telescoping surface.

NOTE: Use only a grade Type II tube grease. Do not grease the slip clutch assembly.

3. Before each use check to make sure all safety shields are installed and working properly.
4. Check tiller tines for cracks and breaks before every use.
5. Periodically check all nuts and bolts to insure they are tight and secure.
6. Periodically loosen torque spring bolts and allow slip clutch to slip for approximately two (2) revolutions. Loosen the bolts until the springs lose contact with the flange yoke. This ensures that the slip clutch is not in a "locked" position.
7. Make sure that the clutch slips.
8. To retighten the slip clutch, tighten the torque spring bolts until the nut makes contact with the flange yoke and further tighten one and a half turns (1 1/2). This is a good starting point, further adjustments may need to be made based on soil conditions.

NOTE: Do not over or under tighten slip clutch assembly or damage may occur.

OWNER SERVICE

The information in this section is written for operators who possess basic mechanical skills. If you need help, your dealer has trained service technicians available. For your protection, read and follow the safety information in this manual.

WARNING

- **Keep all persons away from operator control while performing adjustments, service, or maintenance.**

CAUTION

- If you do not understand any part of this manual and need assistance, see your dealer.
- Always wear relatively tight and belted clothing to avoid getting caught in moving parts. Wear sturdy, rough-soled work shoes and protective equipment for eyes, hair, hands, hearing and head.

WARNING

- **Never go underneath equipment (lowered to the ground or raised) unless it is properly blocked and secured. Never place any body part underneath equipment or between moveable parts even when the engine has been turned off. Hydraulic system leak down, hydraulic system failures, mechanical failures, or movement of control levers can cause equipment to drop or rotate unexpectedly and cause severe injury or death. Follow Operator's Manual instructions for working underneath and blocking requirements or have work done by a qualified dealer.**



PARTS SECTION: 4'/5'/6' TILLER

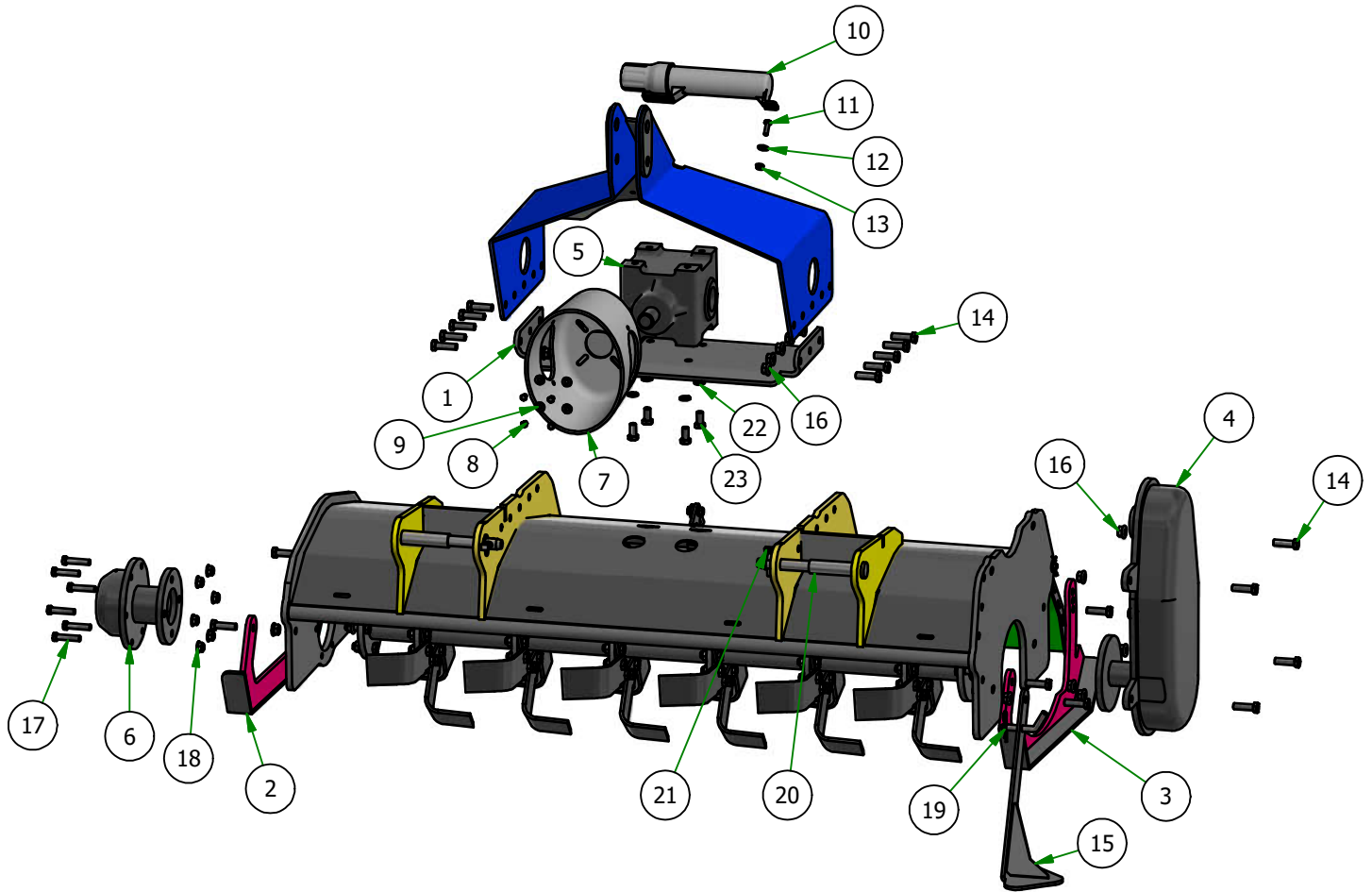

Parts List			
ITEM	QTY	PART NUMBER	DESCRIPTION
1	1	326-0105-00	Tiller Gear Box plate
2	1	301-0044-00	Tiller Skid weldment RH
3	1	301-0045-00	Tiller Skid Weldment LH
4	1	350-0030-00	Side Gear box
5	1	350-0029-00	tiller Gear Box
6	1	322-0012-00	Tiller Bearing Hub
7	1	314-0003-00	PTO Guard
8	4	318-0037-00	1/4-20 x 1/2" Hex Bolt with lock compound
9	4	019-7040-00	1/4 USS FLAT WASHER (3/4 OD) ZINC
10	1	367-0001-00	Document Holder
11	2	018-2007-00	5/16-18 X 1 HEX CAP SCREW (GR.5) ZINC
12	2	019-8044-00	5/16 USS FLAT WASHER (7/8 OD) ZINC
13	2	013-9002-00	5/16-18 HEX SERRATED FLANGE NUT HARD/ZINC
14	27	318-0036-00	1/2-13X1-1.75 Hex C/S Grade 8
15	1	339-0103-00	Tiller Stand Weldment
16	27	013-8050-00	1/2-13 NYLON INSERT FLANGE LOCKNUT ZINC
17	6	318-0038-00	7/16-20 X 2 HEX CAP SCREW (GR.5) ZINC
18	6	313-0025-00	7/16" Nylock Flange nut
19	1	344-2007-00	1/2"x3" Receiver Bent Hitch Pin
20	2	340-0017-00	Cat 1-2 Draw pin
21	2	340-0014-00	7/16"x2x Lynch pin
22	4	019-5007-00	1/2 SPLIT LOCKWASHER (GR.8) ZINC/YELLOW
23	4	018-4704-00	1/2-13 X 1 HEX CAP SCREW (GR.5) ZINC



PARTS SECTION: 4'/5'/6' Tiller parts

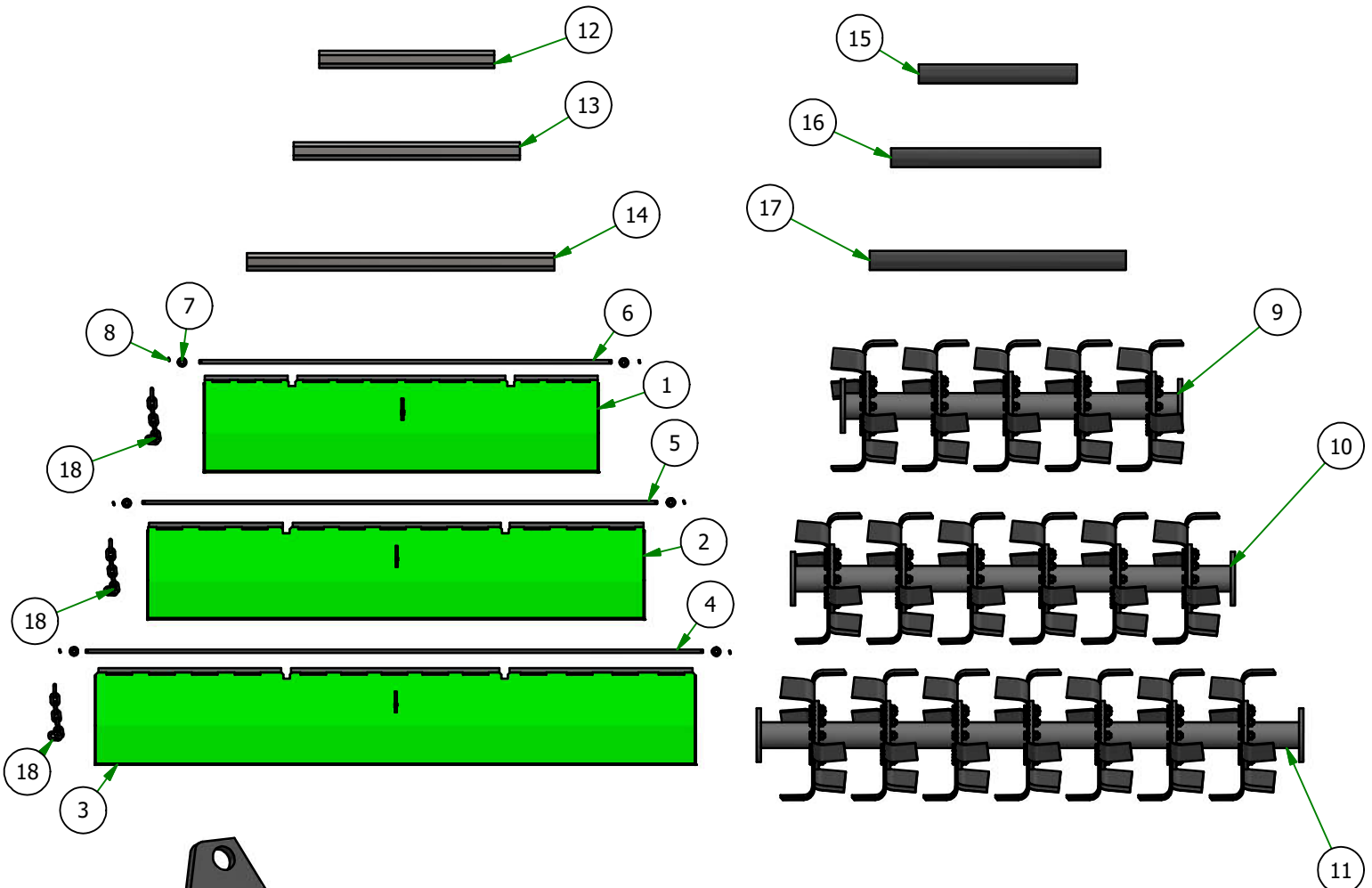

Parts List			
ITEM	QTY	PART NUMBER	DESCRIPTION
1	1	388-3037-00	4ft Tiller Tailgate weldment
2	1	388-3035-00	5ft Tiller Tailgate weldment
3	1	388-3033-00	6ft Tiller Tailgate weldment
4	1	317-0009-00	6ft tiller gate pin
5	1	317-0008-00	5ft tiller gate pin
6	1	317-0007-00	4ft tiller gate pin
7	6	319-0011-00	3/8 FLAT WASHER USS (1" OD) ZINC
8	6	020-7022-00	1/8 X 1-1/2 COTTER PIN ZINC
9	1	317-0001-00	4ft Rotor Bar Assembly
10	1	317-0002-00	5ft Rotor Bar Assembly
11	1	317-0003-00	6ft Rotor Bar Assembly
12	1	317-0004-00	4ft hex bar
13	1	317-0005-00	5 Ft hex bar
14	1	317-0006-00	6 Ft hex bar
15	1	314-0023-00	4ft Hex Bar Sleeve
16	1	314-0024-00	5ft Hex Bar Sleeve
17	1	314-0025-00	6ft Hex Bar Sleeve
18	1	347-0007-00	Tiller Chain Assembly
19	1	338-0020-00	Left Hand Tine
20	1	338-0019-00	Right Hand Tine

WARRANTY

OWNER/OPERATOR'S RESPONSIBILITY

It is the owner and/or operator's responsibility to read the owner's manual before use. Failure to read the owner's manual is considered a misuse of this equipment.

It is the owner and/or operator's responsibility to inspect the product and to have any part(s) repaired or replaced before continued operation. Failure to do so could cause damage, excessive wear to other parts, or jeopardize operator safety.

LIMITED WARRANTY

Bad Boy Implements warrants to the original purchaser of any new Bad Boy Implement(s) that the equipment be free from defects in material and workmanship for a period of one (1) year from date of retail sale. (3 year on Gearbox.)

At Bad Boy Implements request, the customer will make the defective part available for inspection by Bad Boy Implements and/or return the defective part to Bad Boy Implements. Transportation charges prepaid.

WHAT THIS WARRANTY DOES NOT COVER:

This warranty does not cover defects caused by depreciation or damage caused by wear, accidents, improper maintenance, improper use or abuse of the product, alterations, or failure to follow the instruction contained in the Owner's Manual for operation and maintenance.

Normal maintenance service and normal replacement items such as, worn blades, or normal deterioration of exterior finish due to use or exposure.

Bad Boy Implements will not be responsible for the pickup and delivery of a machine for warranty purposes or inspection.

WARRANTY LIMITATION:

THERE IS NO OTHER EXPRESSED WARRANTY. ANY WARRANTY THAT MAY BE IMPLIED FROM THIS PURCHASE INCLUDING MERCHANTABILITY AND FITNESS FOR A PARTICULAR PURPOSE IS HEREBY LIMITED TO THE DURATION OF THIS WARRANTY AND TO THE EXTENT PERMITTED BY LAW ANY AND ALL IMPLIED WARRANTIES ARE EXCLUDED. Some states do not allow limitations on how long an implied warranty lasts, so the above limitations may not apply to you.

BAD BOY IMPLEMENTS WILL NOT BE LIABLE FOR ANY INCIDENTAL, CONSEQUENTIAL, OR SPECIAL DAMAGES AND/OR EXPENSES IN CONNECTION WITH THE PURCHASE OR USE OF THE IMPLEMENT. Some states do not allow the exclusion or limitation of incidental or consequential damages, so the above limitation(s) or exclusion(s) may not apply to you.

HOW TO OBTAIN SERVICE UNDER THIS WARRANTY:

Warranty service can be arranged by contacting the dealer where you purchased the mower or by contacting Bad Boy Implement at **Dustin.Tissiere@badboymowers.com**.

Proof of the date of purchase may be required to verify warranty coverage.

B. Warranty claims will not be reviewed or paid unless the warranty registration is received by Bad Boy Implements within 30 days of the retail purchase date.

Record the model number, serial number and date purchased. This information will be helpful obtaining parts or service if required.

SERIAL NUMBER _____

DATE OF RETAIL SALE _____

PLACE OF PURCHASE _____



102 Industrial Drive
Batesville, Arkansas 72501
(870) 698-0090
