



**BAD BOY
MOWERS**



MAVERICK MODELS

ZERO-TURN MOWER OWNER'S OPERATOR SERVICE AND PARTS MANUAL

For additional information, please see us at
www.badboymowers.com



TABLE OF CONTENTS

Basic Information	Section 1	Page 4
Bad Boy Safety Guidelines.....	Section 2	Page 5
Operation	Section 3	Page 9
Maintenance.....	Section 4	Page 10
Storage and Transportation.....	Section 5	Page 10
Troubleshooting and FAQ	Section 6	Page 12
Controls.....	Section 7	Page 13
Moving In-operable Mower.....	Section 8	Page 14
Instrumentation	Section 9	Page 14
Mower Blade Maintenance.....	Section 10	Page 15
Equipment Lubrication.....	Section 11	Page 15
How To Choose the Right Blade		Page 16
Mowing Tips		Page 17
Service Section		Page 18
Parts Section.....		Page 34
Limited Warranty		Page 56



THIS MANUAL APPLIES TO THE FOLLOWING EQUIPMENT:

BAD BOY MAVERICK SERIES

MAVERICK 4800 48" KT740 Kohler Confidant
 MAVERICK 5400 54" KT740 Kohler Confidant
 MAVERICK 6000 60" KT740 Kohler Confidant
 MAVERICK 4800 48" 726cc FS730V Kawasaki
 MAVERICK 5400 54" 726cc FS730V Kawasaki
 MAVERICK 6000 60" 726cc FS730V Kawasaki
 MAVERICK 4800 48" 688cc GXV630 Honda
 MAVERICK 5400 54" 688cc GXV630 Honda
 MAVERICK 6000 60" 688cc GXV630 Honda

COMMONLY USED ITEMS AND PART NUMBERS

48" MAVERICK Blade	Hi-Lift Fusion 038-5350-00	Gator Blade 038-5000-00	Wave Blade 038-4825-00
54" MAVERICK Blade	Hi-Lift Fusion 038-0001-00	Gator Blade 038-0003-00	Wave Blade 038-5220-00
60" MAVERICK Blade	Hi-Lift Fusion 038-6060-00	Gator Blade 038-6003-00	Wave Blade 038-6016-00
MAVERICK Hydraulic Filter	063-1050-00		
48" MAVERICK Deck Belt	041-1470-00		
54" MAVERICK Deck Belt	041-1560-00		
60" MAVERICK Deck Belt	041-1650-00		
MAVERICK Pump Belt	041-7400-00		
Fuel Filter	Kohler Engines 063-5001-00	Kawasaki Engines 063-6000-00	Honda Engines 015-0091-05
Oil Filter	Kohler Engines 063-5004-00	Kawasaki Engines 063-8017-00	Honda Engines 015-0091-01
Air Filter	Kohler Engines 063-5006-00 Pre-cleaner 063-5005-00	Kawasaki Engines 063-2097-00	Honda Engines 015-0091-02 Pre-cleaner 015-0091-03
Spark Plug	Kohler Engines 015-8000-00	Kawasaki Engines 015-8001-00	Honda Engines 015-0091-04
Motor Oil	10W-30 Motor Oil - Bad Boy Synthetic Blend Motor Oil Recommended. 085-6015-00		
Hydraulic Oil	20W-50 Motor Oil - Bad Boy Hydrostatic Oil Recommended (Approximately 2.5 Quarts/Transaxle) 085-6000-00		



SECTION 1: BASIC INFORMATION

Congratulations on the purchase of your new Bad Boy Mower! The purpose of this manual is to assist operators in maintaining and operating their machine. The information and instructions in this manual can help you attain years of performance from your new Bad Boy. Also, check out our website to learn more about the Bad Boy family.

- 1.1 All Bad Boy engines use 10W-30 engine oil. For maximum protection, Bad Boy synthetic blend engine oil is recommended.
- 1.2 All Bad Boy hydraulic systems use 20W-50 engine oil (Conventional or Synthetic). Bad Boy Hydrostatic oil is recommended.
- 1.3 All Bad Boy Mowers use hi-temp multi-purpose grease. NLGI No. 2 for the grease fittings.
- 1.4 MAVERICK models have 12 psi in both front and rear tires.
- 1.5 Most Kohler, Kawasaki, and Honda engines hold approximately two (2) quarts of motor oil. Be careful not to over fill engine oil. Refer to engine's service manual.

WARRANTY REGISTRATION

The Warranty Registration form must be completed within 30 days to validate your warranty. As the new equipment owner, you are expected to see that the form is completed and forwarded to Bad Boy Inc. at time of delivery. Warranty is nontransferable. **Warranty registration should be completed by the selling dealership using the on-line registration site.**

MODEL/SERIAL NUMBER

Your MAVERICK model serial numbers are found on the SIN plate underneath the seat. These numbers can assist you in the ordering of new parts when replacements become necessary.

PARTS/SERVICE

Bad Boy recommends using Bad Boy replacement parts on your mower. Replacement parts are available through your local Bad Boy Mowers Dealer. Remember to always provide the following information when ordering parts:

1. Correct part number
2. Correct serial number

All warranty repair and service must be handled through your authorized Bad Boy Mowers Dealer. To locate the nearest dealer, go to our website and click on Locate a Dealer.

EVAPORATIVE EMISSION CONTROL WARRANTY STATEMENT

Federal Evaporative Emission Control Warranty: Your Warranty Rights and Obligations

The Environmental Protection Agency (EPA), and Bad Boy Inc. are pleased to explain the evaporative emission control system's warranty on your 2020 equipment. New equipment that uses spark ignition engines for off-road use must meet stringent anti-smog standards. The evaporative emission control system on your equipment is designed, built, and equipped so it conforms at the time of sale to the ultimate purchaser with the requirements of 40 CFR 1060. The evaporative emission control system is free from defects in materials and workmanship that may keep it from meeting said requirements. Bad Boy Inc. must warrant the evaporative emission control system on your equipment for two years provided there has been no abuse, neglect, or improper maintenance. If an evaporative emission control system component does fail in a manner that would cause the equipment to no longer meet the requirements of 40 CFR 1060 within the first two years Bad Boy Inc. will replace the defective component. Your evaporative emission control system may include parts such as fuel tanks, fuel lines, carbon canisters, fuel caps, valves, vapor hoses, clamps, or connectors.



SECTION 2: MOWER SAFETY GUIDELINES

Never allow untrained people to operate this machine. It is the owner's responsibility to get training and see to it that anyone who has permission to use your machine receives the proper training. Do not mow around people. The factory discharge chute is designed to deflect debris downward, but it could be possible for debris to be thrown in a way that can cause damage to people or property. Seek additional training when possible to learn more about safety techniques and practices. **This cutting machine is capable of amputating hands and feet and throwing objects. Failure to observe the following safety instructions could result in serious injury or death.**

GENERAL OPERATION

- 2.1 Read, understand, and follow all instructions on the machine and in the manual before starting.
- 2.2 Do not put hands or feet near rotating parts or under the machine. Keep clear of the discharge opening at all times.
- 2.3 Always remain seated while operating the machine. If the machine is equipped with Roll Over Protection (ROPs), always buckle your seat belt.
- 2.4 Only allow responsible adults who are familiar with the instructions to operate this machine.
- 2.5 Clear the area of objects such as rocks, wire, toys etc., which could be thrown by the blades.
- 2.6 Always maintain a safe distance from people and pets just prior to and during operation. Stop the machine if anyone enters the area.
- 2.7 Never carry passengers.
- 2.8 Do not mow in reverse unless absolutely necessary. Always look down and behind before and while backing.
- 2.9 Never direct discharged material toward anyone. Avoid discharging material against a wall or obstruction as material may ricochet back toward the operator. Stop the blades when crossing gravel surfaces.
- 2.10 Never operate the machine without the discharge chute, grass catcher, or other safety devices correctly in place and functioning properly.
- 2.11 Slow down before turning.
- 2.12 Always disengage blades, place steering controls in neutral, engage parking brake, and remove ignition key when leaving operators seat. Never leave a running machine unattended. Disengage blades when not mowing.
- 2.13 Shut off engine, allow all moving parts to come to a complete stop, and allow to cool before performing any of the following actions: cleaning or inspecting the machine for damage, removing the grass catcher, or unclogging the discharge guard.
- 2.14 Always operate machine in daylight or with adequate working lights.
- 2.15 Do not operate the machine while under the influence of alcohol or drugs.
- 2.16 Watch for traffic when operating near or crossing roadways.
- 2.17 Always wear eye protection when operating or servicing the machine.
- 2.18 Always wear ear protection, such as earplugs, while mowing.
- 2.19 Use extra care when loading or unloading the machine into a trailer or truck.
- 2.20 Be alert of surroundings. Watch for rocks, stumps, mounds, depressions, and low hanging limbs or objects that could be potentially hazardous while mowing.
- 2.21 Data indicates that operators 60 years of age and above are involved in a large percentage of riding mower related injuries. These operators should periodically evaluate their ability to operate the riding mower safely enough to protect themselves and others from serious injury.
- 2.22 Prevent fires by keeping engine and exhaust areas clear of grass clippings and other debris. Do not park or back mower over or immediately adjacent to flammable materials.



SETTING DECK HEIGHT

- 2.23 If your machine is equipped with an actuator motor, raise the deck using the raise /lower switch. Refer to section 7 (Controls). When deck is raised, set desired height with the deck height control dial, then lower deck with the raise / lower switch.
- 2.24 If your machine is equipped with a foot pedal, press foot pedal to raise deck, select your desired deck height with the deck height dial, then slowly release foot pedal.

SLOPE OPERATION

Slopes are a major factor related to loss of control and tip over accidents, which can result in severe injury or death. Operation on all slopes requires extra caution. If you cannot back up the slope, or you feel uneasy on it, do not mow it. **Avoid operating your mower on side hills of over 5 degrees, inclines of over 10 degrees, and declines of over 15 degrees.**

- 2.25 Mow up and down slopes, not across.
- 2.26 Watch for holes, ruts, bumps, rocks, or other hidden objects that tall grass can obscure. Uneven terrain could overturn the machine.
- 2.27 Choose a low ground speed when operating the machine on a slope.
- 2.28 Do not mow on wet grass, the tires may lose traction.
- 2.29 Do not attempt to coast down a slope in the neutral position.
- 2.30 Avoid starting, stopping, or turning on a slope. If the tires lose traction, disengage the blades and proceed slowly, straight down the slope.
- 2.31 Keep all movement on slopes slow and gradual. Sudden changes in speed or direction could cause the machine to roll over.
- 2.32 Use extra care while operating machine with grass catchers or other attachments: they can affect the stability of the machine. Do not use on steep slopes.
- 2.33 Do not try to stabilize the machine by putting your foot on the ground.
- 2.34 Do not mow near drop offs, ditches or embankments. The machine could suddenly roll over if a wheel goes over the edge or the edge caves in.
- 2.35 Be aware of what is located at the bottom of slopes. For example: rocks water, cliffs, and roadways.

CHILDREN

Tragic accidents can occur if the operator is not alert to the presence of children. Children are often attracted to the machine and the mowing activity. NEVER assume that children will remain where you last saw them.

- 2.36 Keep children out of the mowing area and in the watchful care of a responsible adult other than the operator.
- 2.37 Maintain Alertness and turn machine off if a child enters the area.
- 2.38 Before and while backing, look behind and down for small children.
- 2.39 Never carry children, even with blades shut off. They may fall off and be seriously injured or interfere with safe machine operation. Children who have been given rides in the past may suddenly appear in the mowing area for another ride and be run over or backed over by the machine.
- 2.40 Never allow children to operate the machine.
- 2.41 Never leave the key in the ignition, especially around children.
- 2.42 Use extreme care when approaching blind corners, shrubs, trees, or other objects that may block your view of a child



TOWING

- 2.43 Tow only with a machine that has a hitch specifically designed for towing. Do not attach towed equipment except at the hitch point.
- 2.44 Follow the manufacturer's recommendation for weight limits for towed equipment and towing on slopes.
- 2.45 Never allow children or others in or on towed equipment.
- 2.46 On slopes, the weight of the towed equipment may cause loss of traction and loss of control.
- 2.47 Travel slowly and allow extra distance to stop.

SERVICE

SAFE HANDLING OF GASOLINE

To avoid personal injury or property damage, use extreme care in handling gasoline. Gasoline is extremely flammable and the vapors are explosive.

- 2.48 Extinguish all cigarettes, cigars, pipes, and all other sources of ignition.
- 2.49 Use only an approved gasoline container.
- 2.50 Never remove gas cap or add fuel with the engine running.
- 2.51 Allow engine to cool before refueling.**
- 2.52 Never fuel the machine indoors.
- 2.53 Do not store machine near open flame or source of ignition, such as a water heater or furnace.
- 2.54 Remove gas powered equipment from the truck or trailer and refuel it on the ground. If this is not possible, then refuel such equipment with a portable container, rather than from a gasoline dispenser nozzle.
- 2.55 Never fill gasoline containers inside a vehicle or on a truck or trailer bed with a plastic liner. Always place containers on the ground away from your vehicle before filling.
- 2.56 Keep the nozzle in contact with the rim of the fuel tank or container opening at all times until the fueling is complete. Do not use a nozzle lock-open device.
- 2.57 If fuel is spilled on clothing, change clothing immediately.
- 2.58 Never overfill fuel tank. Replace gas cap and tighten securely. **Tank is full when level reaches bottom of fill tube.**

GENERAL SERVICE

- 2.59 Never operate machine in a closed area where dangerous carbon monoxide fumes can collect.
- 2.60 Keep all nuts and bolts tight to be sure the equipment is in safe working condition. Never operate a poorly maintained machine.
- 2.61 Do not touch hot areas of the machine.
- 2.62 Never interfere with the intended function of a safety device or reduce the protection provided by a safety device. Check their proper operation regularly.
- 2.63 Keep the entire machine free of grass, leaves, or other debris build up. Clean up oil or fuel spillage and remove any fuel-soaked debris. Failure to do so can affect the safety and functionality of the machine, as well as increase the danger of a fire due to contact with the hot surfaces of the machine.
- 2.64 Allow machine to cool before storing.
- 2.65 If you strike something with the mower, turn the mower and blades off, engage the parking brake, and inspect the machine for damage. Repair, if necessary, before resuming.
- 2.66 Never make any adjustments or repairs with the engine running.
- 2.67 Check grass catcher components and the discharge guard frequently and replace with manufacturer's recommended parts, when necessary.
- 2.68 Mower blades are sharp. Wrap the blade or wear gloves before servicing them.



- 2.69 Check parking brake operation frequently. Adjust and service as required.
- 2.70 Maintain or replace safety and instruction labels, as necessary.
- 2.71 Do not attempt to mount a tire without the proper equipment and experience to perform the job.
- 2.72 Always maintain the correct tire pressure. Do not inflate the tires above the recommended pressure. Never weld or heat a wheel and tire assembly. The heat can cause an increase in air pressure resulting in a tire explosion. Welding can structurally weaken or deform the wheel.
- 2.73 Park machine on level ground. Never allow untrained personnel to service machine. Understand service procedures before doing work.
- 2.74 Mower deck, frame, and engine compartment should remain free of debris to prevent premature part failures or fire hazards.

SAFETY INTERLOCK SYSTEM

Your Bad Boy mower is equipped with a safety interlock system. This system is designed to prevent serious injury or death to the operator and other people or property damage. The system consists of an operator presence switch in the seat, the parking brake, drive lever neutral position, the mower blade engagement switch, and the ignition switch. These interlocks are vitally important and must be tested frequently. Following are instructions to test these very important safety precautions. **Note: the operator must be seated properly on the machine during these tests and the engine should have been previously allowed to warm to operating temperature.**

- 2.75 With the parking brake engaged, bring lever arms to their inward position. Attempt to start the machine with the blade actuator in off position. The engine should not start.
- 2.76 On a level surface, disengage the parking brake and place lever arms to their outward position. Then, attempt to start the machine with the blade actuator in off position. The engine should not start.
- 2.77 Engage parking brake and leave lever arms in outward position. Put blade actuator in the on position, then attempt to start the machine. The engine should not start.
- 2.78 Next, start the engine as stated in the Mower Operation Section. Disengage parking brake. Very slowly begin to rise from the seat. The engine should stop.

If any of these tests fail to produce the results indicated and the problem cannot be identified, contact your Bad Boy Mower dealer or the support contacts in the back of this manual.

ROLL OVER PROTECTION STRUCTURES (ROPS)

This machine is equipped with ROPS from the factory. It is vital that the rules below are adhered to. ROPS, when used correctly, dramatically decrease the fatality rate in roll-over instances.

- 2.79 Periodically ensure the bolts that attach the ROPS to the machine are securely fastened.
- 2.80 Always operate the machine with the ROPS secured in the upright position.
- 2.81 If the surrounding environment (e.g. low-lying limbs, signage, etc.) makes it impossible to mow with the ROPS upright, lower the ROPS at the hinge point, mow the area, then immediately secure the ROPS upright.
- 2.82 Upright ROPS are taller than the operator's head. Be aware of this and your surrounding environment, as referenced above. The mower and operator may clear low lying items, but the ROPS may not.
- 2.83 Always wear the provided seat belt when ROPS are utilized. Failure to use the seat belt severely handicaps the safety benefits of the ROPS.
- 2.84 In the event of a roll-over, replace the ROPS before resuming use of the machine.



SECTION 3: MOWER OPERATION

Never operate the machine with faulty equipment. Always be alert of sudden changes in landscape, as the mower will react differently on slopes or embankments than it will on flat surfaces. Never operate the mower with the discharge chute open. Do not cross terrain, other than grass, with blades turning. This could cause damage to property or bystanders.

- 3.1 Place parking brake in up position.
- 3.2 Drive arms must be in the “open” position. While sitting on the machine, each arm is positioned away from the operator, to the right and left. Drive arms will lock into place and must be in this position to start machine.
- 3.3 Put PTO switch in the OFF position.
- 3.4 If your machine has been equipped with a ROPS (Roll Over Protection System) then you must fasten seatbelt.
- 3.5 If machine has not been started recently, engage the choke.
- 3.6 Make sure nothing is under or around machine.
- 3.7 Place key in ignition and turn.
- 3.8 Once machine is started, disengage the choke.
- 3.9 Increase RPM by sliding the throttle to fast position, toward the rabbit.
- 3.10 Owners must become familiar with the controls before operating a zero-turn radius vehicle.
- 3.11 Start slowly and build your skill level. Have ample practice before using the machine at full capabilities.
- 3.12 Be comfortable with machine before engaging blades. Know what each component controls before using machine.
- 3.13 Your mower will perform differently on an incline /decline. Be cautious, slow down, and do not make any sudden jerking movements with control arms. The machine could lose traction on a decline or tip backwards on an incline.
- 3.14 Once you become comfortable with your Bad Boy Mower you will notice your overall mowing time will decrease.
- 3.15 Always engage PTO at full throttle.
- 3.16 Start engine with throttle position between half and full throttle.

***Avoid operating your mower on side hills of over 5 degrees,
inclines of over 10 degrees,
and declines of over 15 degrees.***



BAD BOY MOWERS

SECTION 4: MOWER MAINTENANCE

Maintenance	Interval					Section
	Daily	First 8 Hours	Every 50 Hours or Annually*	Every 100 Hours or Annually*	Every 250 Hours	
Check and add engine oil	●					Section 3
Check all belts for proper alignment	●					Section 2 (Pump) 6 (Deck)
Check tire pressure and wheel lug nuts	●					Section 5
Check battery terminal connections	●					Section 4
Check condition of blades	●					Section 6
Check for fuel and oil leakage	●					Section 3
Check deck and engine compartment for debris and clean as necessary	●					
Check air filters	●					
Initial oil change		●				Section 3
Tighten nuts and screws			●			
Change engine oil and filter			●			Section 3
Initial change of hydraulic oil and filter			●			Section 1
Grease mower				●		Section 5
Replace air element and pre-cleaner [♦]				●		Section 3
Replace fuel filter [♦]				●		Section 3
Clean or replace spark plugs and set gap				●		Section 3
Change hydraulic oil and filter					●	Section 1
Clean combustion chamber ^{Dealer}					●	
Check and adjust valve clearance ^{Dealer}					●	
Clean and lap valve seating surface ^{Dealer}					●	

*Maintenance by hour or annually whichever comes first

[♦]Check air and fuel filter more often in dusty conditions

^{Dealer}Get maintenance performed at a registered dealership

SECTION 5: MOWER STORAGE & TRANSPORTATION

- 5.1 Keep machine from collecting debris by storing in a covered area while not in use.
- 5.2 Fuel can harm your machine if left for more than 30 days without changing, especially if the fuel contains ethanol. Never use fuel with more than 10% ethanol by volume. E-15 is not permitted.
- 5.3 Disconnect the negative battery cable when machine will be stored for more than 30 days.
- 5.4 Always secure machine properly when transporting machine.
- 5.5 Do not load machine on trailer with blades engaged.
- 5.6 Do not use ramps to load the machine.
- 5.7 Make sure Parking Brake is in "up" position.
- 5.8 In wet conditions tires may spin while loading / unloading. If necessary, wait for dry conditions before loading/unloading.
- 5.9 Make sure mode of transportation is suitable to bear the weight of mower.
- 5.10 Deck height should be set at maximum before attempting to load.
- 5.11 Secure mower with at least two straps capable of securing weight of mower.
- 5.12 Always ensure mower engine and exhaust has cooled prior to parking inside building.



SECTION 6 : TROUBLESHOOTING

6.1 **Q: *How do I prevent an uneven cutting pattern and increase the quality of cut?***

A: Check tire pressure, check blade sharpness (replace blades or sharpen at least once per year or when needed), make sure blades are tightened properly, check spring and belt tension, check the underside of the deck to ensure the mower deck is free of grass build-up and debris, make sure your machine is at full throttle, and vary your mowing pattern each time you cut your grass.

6.2 **Q: *What should I do if my mower won't start?***

A: Check battery charge and connection (grounds), check your fuel (make sure fuel is less than 30 days old and contains no water), make sure your spark plug is in good condition and spark plug wire is attached, make sure air filter is clean (a dirty filter makes it more difficult for the engine to draw air), check the integrity of the 25-amp main fuse, and check for any bare wires and/or bad connections.

6.3 **Q: *What should I do if the blades won't engage?***

A: Make sure the safety switch is plugged in on the bottom of seat. Check the underside of the PTO engager to ensure the plug is secure at switch. Also check PTO fuse underneath operator console (10-amps)

6.4 **Q: *What type of fuel is recommended for my mower?***

A: We recommend that you use a name brand fuel to ensure quality. Use fuel with an octane rating near 87. Higher octane fuels offer no benefit. Only fuels with an ethanol content of 10% or less may be used. By law, E-15 fuel is not permitted. Usage of E-15 will result in premature engine failure.

6.5 **Q: *Do you offer touch-up paint for your mowers?***

A: Touch-up paint is available. Contact your local dealer for more information.

6.6 **Q: *How do I clean my mower?***

A: It is recommended that you use an air hose or blower to remove dust and debris from the mower, to ensure there is not a buildup of grass on the mower deck and engine compartment, which could become a fire hazard. If you must wash the mower, ensure you run the engine to operating temp to dry water and engage the blades to spin off any standing water on the pulleys. Avoid spraying water onto electrical components and bearings, to prevent premature failure of these parts.



SECTION 7: CONTROLS

- 7.1 **Ignition Switch:** Bad Boy mowers have a three-position ignition switch: off, run, and start. With key inserted, rotate it clockwise to START position and release key when engine starts. Switch will automatically return to the RUN position.
- 7.2 **Throttle Control:** A cable is connected to the engine throttle for controlling engine speed. Move lever forward to increase engine rpm, move lever backward to decrease engine rpm.
- 7.3 **Choke Control:** The choke control, located to the operator's left, is a 'push-pull' type. When the choke knob is pushed in, the choke is in the off (run) position. When the choke is pulled out it is in the on (start) position. **Do not operate the machine in the on (start) position.**
- 7.4 **Control Levers:** These levers control the mower's speed, direction, and neutral lock. These levers are used to steer, accelerate, decelerate and change direction.
- 7.5 **PTO Switch:** This switch engages the blades. Pull the switch up to engage the blades and push the switch down to disengage the blades.
- 7.6 **Deck Height Control:** The deck height dial is used to set the cut height of the deck.
- 7.7 **Parking Brake:** The parking brake is used to hold the mower in place.

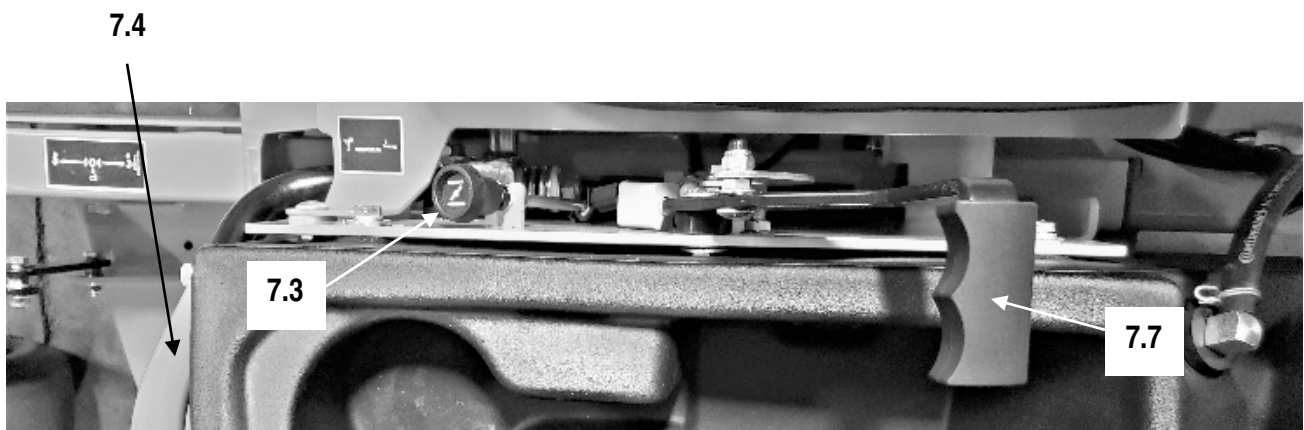
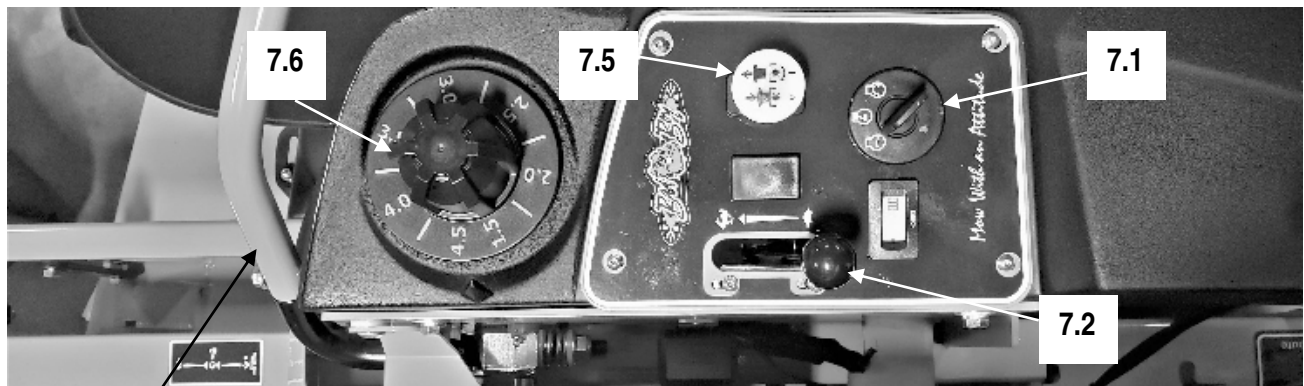



SECTION 8 : MOVING INOPERABLE MOWER

- 8.1 Do not tow machine. Use a winch to load on a trailer for transporting.
- 8.2 MAVERICK Models are equipped with two neutral engage/disengage arms, located at the rear of the mower protruding from the frame and under the muffler. By pulling the arms out, the mower can be put in a neutral position. Return the arms to the “forward position” for normal operation.

Your Bad Boy Mower Weighs: **MAVERICK SERIES: 890-950 lbs.**

****Weights fluctuate with the addition of accessories.*

- 8.3 As you can see by the weights of the machines, you shouldn't ever try to push or pull a Bad Boy Mower by hand. This could cause serious bodily injury.
- 8.4 Hopefully, you'll never need to use this section of the manual. However, if you do, use extreme caution when moving machine!

SECTION 9 : INSTRUMENTATION

- 9.1 **Electronic Hour Meter:** Registers Hour increments up to 9,999.9 total hours. This meter records the cumulative time the engine is running.



SECTION 10: MOWER BLADE MAINTENANCE

- 10.1 Check mower blades after each use. This is essential for maintaining well-groomed turf. Keep the blades sharp. If a dull blade is used for cutting, the grass will tear rather than cut. This could damage the grass leaving a brown frayed top on the grass within a few hours. A dull blade will also require more power from the engine.
- 10.2 NEVER attempt to straighten a bent blade by heating. NEVER attempt to weld a cracked blade. The blades can break and cause serious injury or death.
- 10.3 NEVER work with blades while engine is running or PTO clutch is engaged.
- 10.4 ALWAYS place PTO clutch in DISENGAGE position while performing maintenance.
- 10.5 Use approved lifting equipment when working underneath your mower.
- 10.6 ALWAYS wear thick gloves when handling blades.
- 10.7 ALWAYS check for blade damage if mower strikes rock, branch, or other objects that could potentially damage the blade.

***(REMEMBER: NEVER CHECK BLADE WHILE ENGINE IS ON!
NEVER CHECK BLADES WHILE BLADES ARE ENGAGED!)***

SECTION 11: EQUIPMENT LUBRICATION

- 11.1 Park the machine on a level surface and disengage the blade control switch.
- 11.2 Move the motion control levers outward to the neutral position, engage parking brake, stop the engine, remove the key, and wait for all moving parts to stop before leaving the operating position.
- 11.3 Grease Type: NLGI grade #2 multi-purpose gun grease.
- 11.4 Clean the grease fittings with a cloth. Scrape any paint off the front face of the fitting(s).
- 11.5 Connect a grease gun to each fitting. Pump grease into the fitting until grease seepage is observed. Be mindful of over-pressurization. Do not force the grease into the component if excessive back pressure is felt as this can lead to reduced life of the component(s). Wipe up excess grease.
- 11.6 Refer to service manual section for grease fitting locations.



HOW TO CHOOSE THE RIGHT BLADE

Essentially there are only TWO basic styles of mowing blades used or approved for use on our current products:

1. The standard style of mowing blade is essentially designed for cutting grass and effectively discharging the clippings out from the deck to fall onto the lawn or to be captured in a grass collection system. Standard blades are also referred to as “2-in-1” (discharging & bagging) or “high-lift” blades (because they are designed to create a higher-lifting airflow).
2. Mulching blades generally have a more curved style surface and frequently include extra cutting surfaces along the blade edges. These blades may also come in a “+” design (which is actually two individual blades arranged in a perpendicular fashion to enhance mulching). The “+” blades are usually found on older style mowers; newer ones utilize blades with more advanced mulching technology. Mulching blades may also be referred to as “3-in-1” (mulching, discharging & bagging) or “all-purpose” blades.

Bear in mind that the re-circulating airflow design of 3/1 blades makes them less efficient at discharging grass clippings than a standard 2/1 blade. As with most all-purpose tools, there is some give and take as opposed to using a tool designed for a more specific purpose.

If you're experiencing less-than-desired cutting or discharging performance with a 3/1 blade, you may want to check into using a 2/1 blade. Conversely, if you're using a 2/1 blade and want to mulch clippings, you should see about the availability of mulching blades or a mulching kit. *

The type of blade installed on a new mower is a decision the retailer makes for each model of mower, based on the expected needs of most customers. If you're unsure of which blade is on a particular model, inspect the blade. Blades have part numbers stamped into them. Then compare these part numbers with the unit's Operator's Manual or Parts List.

It is true there are many other styles of blades available. But since we don't manufacture or recommend using these other aftermarket styles, we will leave them out of this discussion. Should you want more information on special application or aftermarket blades, you should contact the companies that make these products. NOTE: Customers using non-OEM blades do so at their own risk. The use of unapproved (non-OEM) blades may void any or all of the mower and engine factory warranties.

* **MULCHING KITS** – These generally consist of mulching blades and a mulching plug (which closes off the discharge opening to keep the clippings contained under the deck for re-cutting) plus any necessary hardware for installation. Please check with your parts distributor regarding the contents of a particular mulching kit.



MOWING TIPS:

- Mow header strips at the ends of the lawn and around flower beds first. Make them wide enough that you can turn the mower around in the already mown section. Then mow back and forth between these header strips overlapping each lap by about 1/8 the width of the mower's deck.
- Don't cut your grass too short, particular for cool season grasses. Higher heights usually provide for a deeper root system, looks better, and is less likely to have weeds invading, particularly crabgrass.
- Don't remove any more than one third of the grass leaf at any one cutting. If circumstances arise that a lawn gets too tall and you just have to lop off a bunch to get caught up, bite the bullet and break it down into several mowings to get caught up with 3 or so days between cuttings.
- NEVER SCALP YOUR LAWN.** Scalping severely damages the root system to such a degree that it may die.
- Avoid mowing when the grass is wet or when it's dark
- Avoid throwing grass clippings into the street and driveway where they can be washed into the sewer system. After mowing, clean up driveway and walkways.
- When mowing remove only a third with each cutting (except for the first mowing of the season when it's ok to remove more). You can safely leave clippings that will quickly decompose and add nutrients back into the soil. Contrary to popular opinion, grass clippings do not add to thatch buildup. Grass blades are made up of about 75% water.
- Mow your lawn in a different direction with each mowing, especially with lawns of shorter grass types. Altering the direction ensures a more even cut since grass blades will grow more erect and less likely to develop into a set pattern.
- Keep your mower's blade sharp, which means having it sharpened several times during the mowing season. Keep several blades around so you'll always have a sharp one on hand. Sharp blades cut the grass cleanly and help mulch clippings into small pieces which break down quickly.
- Don't forget to change your mower's oil at least once during the mowing season. For brand new mowers, change the oil after about 5 hours of operation during the initial break-in period.
- At the end of the mowing season use a fuel stabilizer in the remaining gasoline
- In the spring, don't use that old gas unless you properly used a fuel stabilizer, it can cause a number of problems. Better to use fresh gasoline to begin the new mowing season.
- Leaf blade A** demonstrates what a leaf blade should look like after mowing with a sharp blade.
- Leaf blade B** demonstrates a leaf blade that was injured by a dull mower blade.
- Leaf blade C** was cut by the mower but indicates that the mower blade is not sharp enough. The shredded white tissue protruding from the leaf blades C and D is the vascular tissue of the plant.
- Leaf blade D** has been mown for quite some time with a dull mower blade.

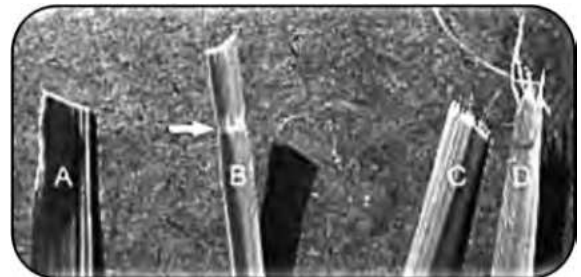

TOBAG OR TOMULCH?

Grass clippings do not contribute to thatch buildup or increase the chances of disease. If you mow your lawn at the right height, without removing any more than 1/3 of its total height, clippings will quickly breakdown without a trace. These clippings contribute additional nitrogen and other nutrients to the soil and supply it with additional organic materials. Clippings from a 1000 sq. ft. lawn can add as much as 1 - 2 pounds of nitrogen back into the soil. If you have a compost pile, then you may want to bag your clippings occasionally to add much needed green-matter to the compost pile. Make sure it is mixed thoroughly with brown matter to avoid a strong ammonia odor. **DO NOT COMPOST CLIPPINGS** after applying any weed control or weed-feed type product. Before adding clippings to the compost pile wait at least 3 mowings after these products have been applied.



SERVICE SECTION

SECTION 1: HYDROSTATIC SYSTEM

The hydraulic fluid reservoirs are accessed by raising the seat forward. Notice the “full cold” line at the bottom of the tank. Use only 20W-50 motor oil in this tank. (Bad Boy Hydrostatic oil is recommended)

CHANGING YOUR HYDRAULIC OIL AND FILTER

1. Remove the caps from the hydraulic fluid reservoirs and get an oil drain pan. Lifting the mower from the rear will make access to the transaxles easier and allow you to purge the air from the transaxles.
2. Remove the two 1/4" filter guard screws and filter guard from the transaxle. Clean any loose debris from around the perimeter of the filter.
3. Place the oil drain pan under the oil filter as the oil filter serves as the drain for the transaxle.
4. After the oil has drained, wipe the filter base surface off and apply a film of new oil to the gasket of the new replacement filter.
5. Install the new filter by hand, turn 3/4 to one full turn after the filter gasket contacts the filter base surface.
6. Re-install the filter guard with two 1/4" screws. Torque screws to 65 in. lbs. (7.3 Nm) each.
7. Repeat steps 1-6 on the opposite side transaxle drive.
8. Drain old oil filters of all free-flowing oil prior to disposal. Place used oil in appropriate containers and deliver to an approved recycling collection facility.
9. Remove the top port plug from the left side and right-side transaxles prior to filling with oil. This will allow the transaxles to vent during oil fill and prevent any air lock within the transaxles.

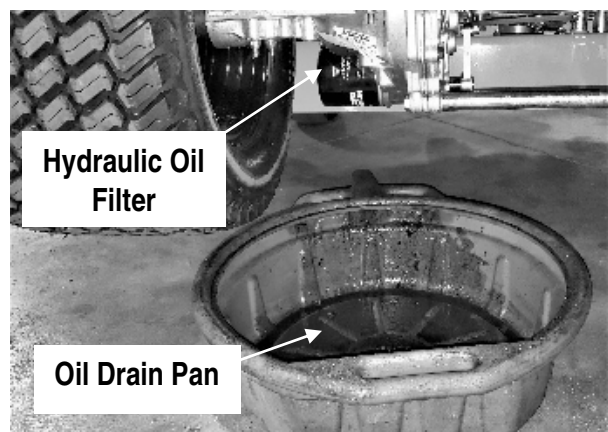
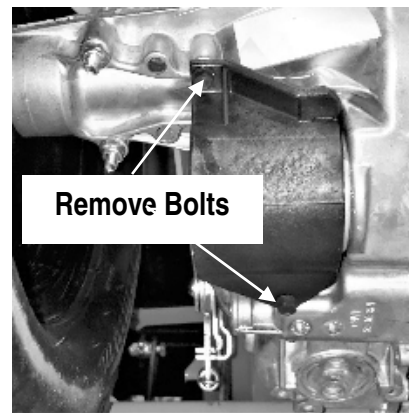
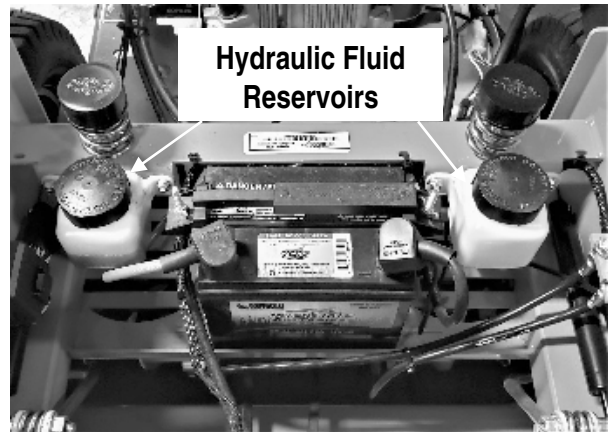



CHANGING YOUR HYDRAULIC OIL AND FILTER (CONTINUED)

10. Fill with 20W-50 motor oil (Bad Boy Hydrostatic oil is recommended) through the hydraulic fluid reservoirs until it just appears at the bottom of each transaxle's top port (approximately 2 quarts per transaxle, 4 quarts total). Install the top port plug into each transaxle as the oil level reaches this port.
11. Install and torque the top port plugs to 180 in. lbs. (20.3 Nm).
12. Continue to fill the transaxle through the hydraulic fluid reservoirs until the "Full Cold" line is reached on the hydraulic fluid reservoirs.
13. Re-install the caps on the hydraulic fluid reservoirs.
14. To purge the air from the transaxles, pull the neutral bypass rods located on each side of the muffler, and pin them into place. Lift the rear of the mower off the ground and start the engine.
15. Release parking brake, then slowly move the drive arms in the forward and reverse directions 5 to 6 times.
16. Take note the muffler will be hot. Push the neutral bypass levers back into place. Move the drive arms forward and backward 5 to 6 times slowly. Check the oil level and add oil as required after stopping the engine.
17. It may be necessary to repeat steps 15 and 16 until all the air is completely purged from the system. When the transaxle operates at normal noise levels and moves smoothly forward and backward at normal speeds, then the transaxle is considered purged.

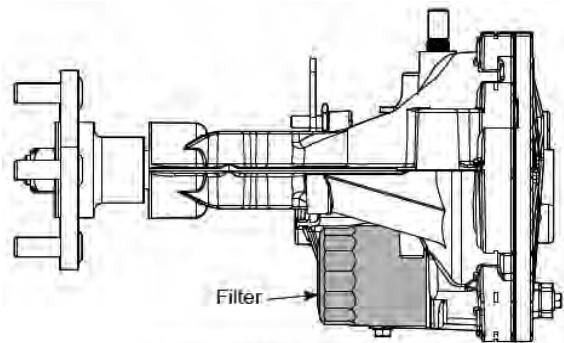
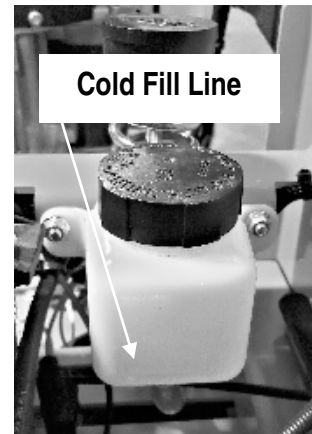
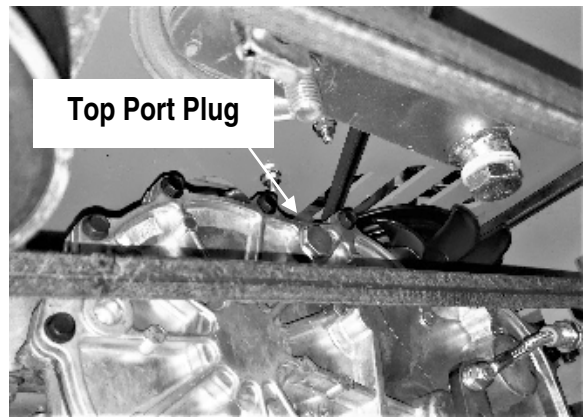

(Guard Removed For Visual Clarity)

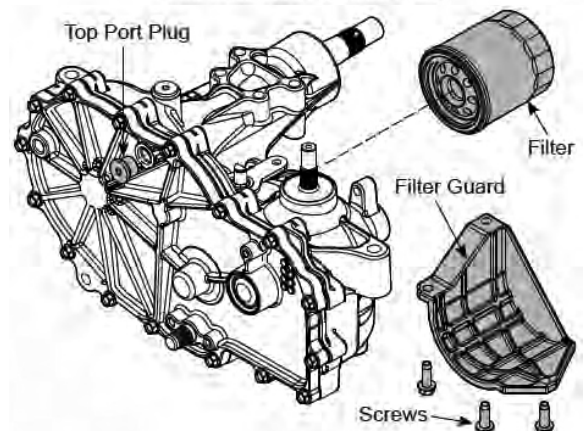



BAD BOY MOWERS

Under the rear of the mower, you will find the two levers shown in the image. These bypass levers serve as a neutral for moving the mower while the engine is not running. Pull the levers out and lock them into place using the cotter pin to activate the bypass.

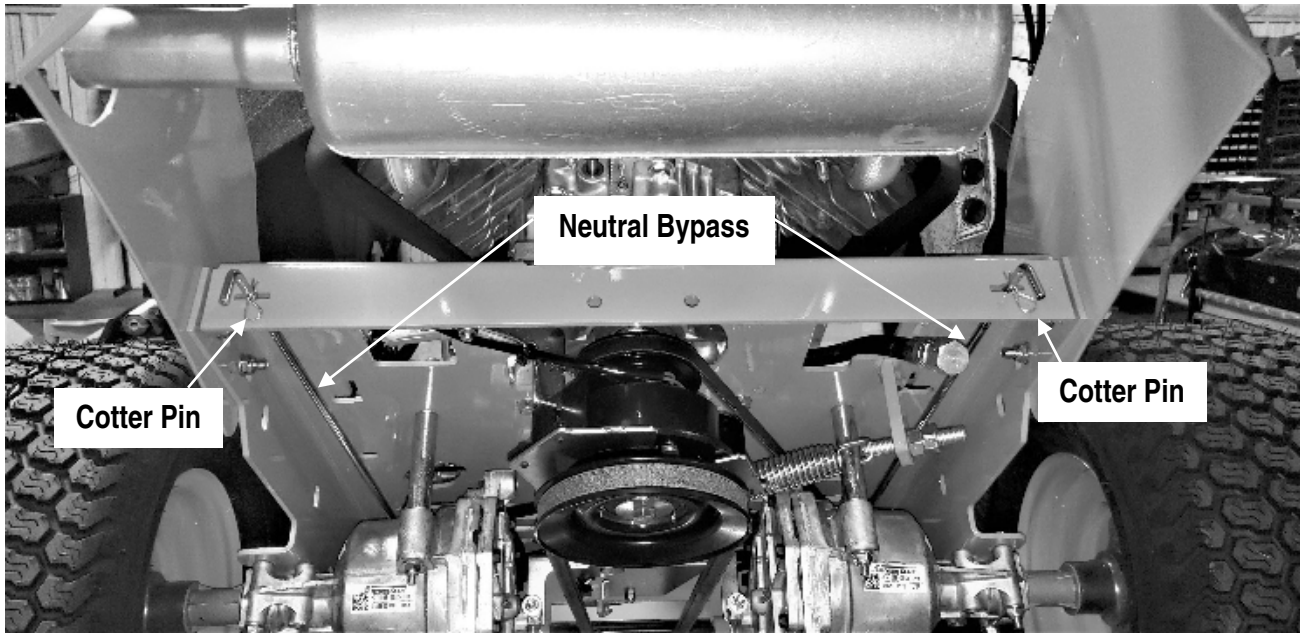

When adjusting the tracking on the mower, the length of the pushrods can be changed by screwing the swivel joint in or out on the ends of the rods. Shortening the overall length of the rod slows the pump down. Lengthening the rod will increase the speed of the pump.

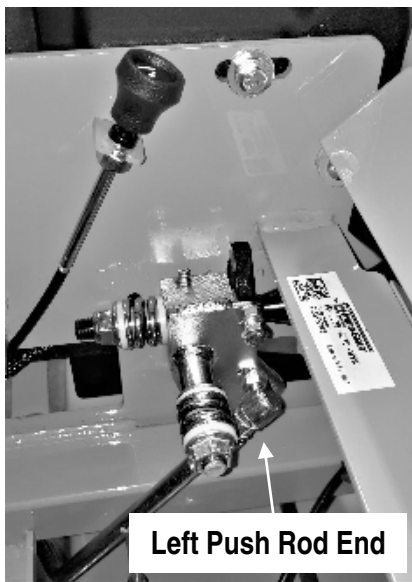

Left Push Rod End



Right Push Rod End



SECTION 2: DRIVE BELT

Shown to the right is the pump belt tensioner. Using a 3/4" wrench, tightening the two jam nuts on the right side will increase the belt tension.

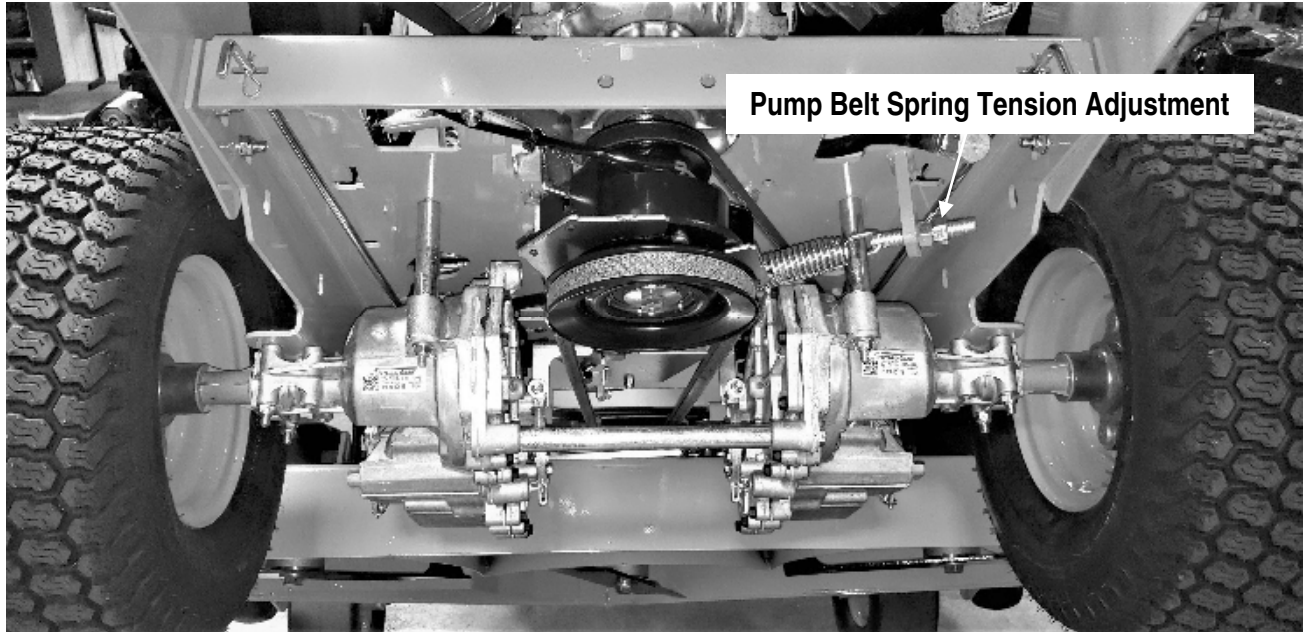

The tension should be adjusted so that there is between 60 to 65 lbs. of tension on the belt. This can be checked with a belt tension gauge (Part Number 041-9999-00) as shown to the right.

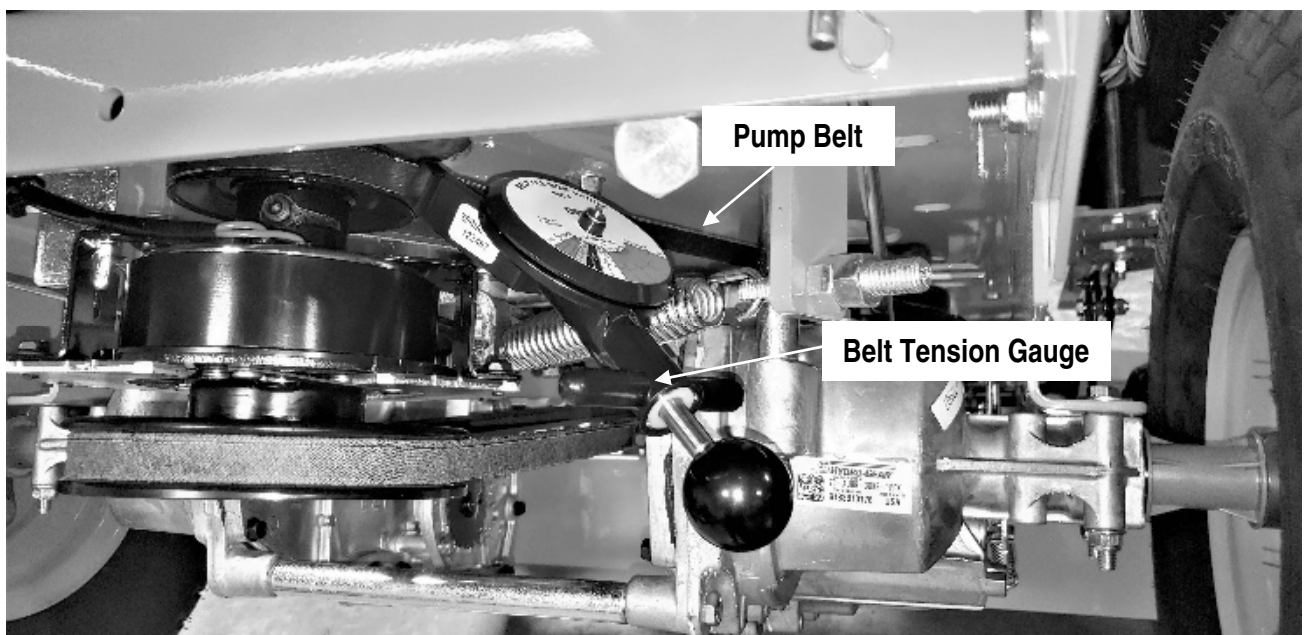



SECTION 3: ENGINE

ENGINE OIL

This machine has an oil drain hose installed on the engine to allow for easier oil changes. Bad Boy recommends that the oil and filter be changed after the initial 8 hrs. of use, and at intervals of 50 usage hours or yearly, whichever occurs first after that. The oil capacity is 2 quarts. Bad Boy 10W-30 synthetic blend engine oil is recommended for maximum protection.

CHANGING YOUR ENGINE OIL AND OIL FILTER

1. Remove oil dipstick and open oil drain. Allow oil to completely drain. (Make sure to have an oil pan ready to capture old oil and properly dispose old oil.)
2. Clean area around oil filter. Place a container under the oil filter to capture any oil and remove filter. Wipe off mounting surface and reinstall drain plug. Torque to 10 ft.*lbs.
3. Place new filter in shallow pan with open end up. Fill with new oil until oil reaches the bottom of the threads. Allow two minutes for oil to be absorbed by filter material.
4. Apply a thin film of clean oil to rubber gasket on new filter.
5. Refer to instruction on oil filter for proper installation.
6. Fill crankcase with approximately 2 quarts of new oil. Level should reach top of indicator on dipstick.
7. Reinstall oil filter dipstick and tighten securely.
8. Start engine; check for oil leaks. Stop Engine; correct oil leaks. Recheck oil level.
9. Dispose of used oil and filter in accordance with local ordinances.

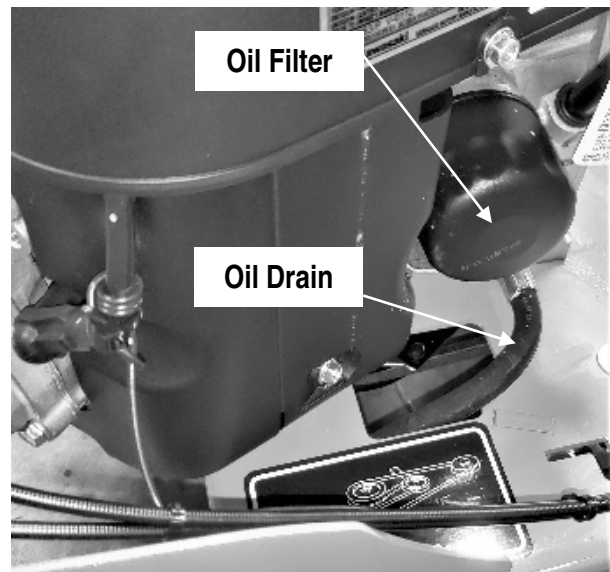
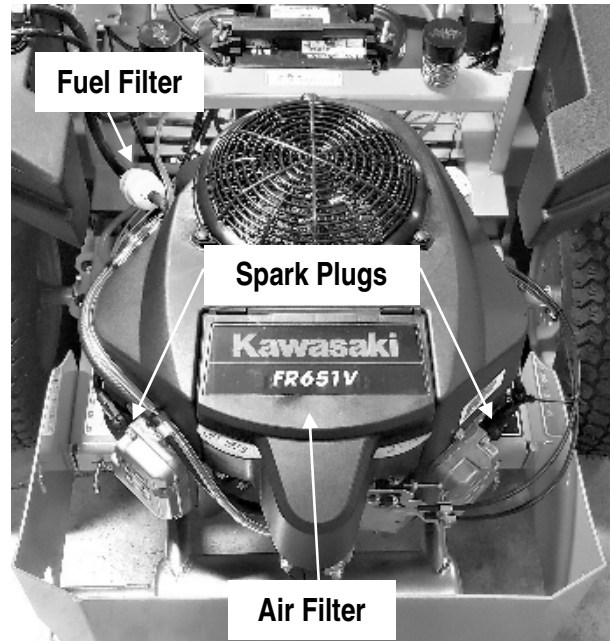



FUEL FILTER

The fuel filter is located in the fuel line. Replace the filter yearly. Prior to the removal of the old filter, note the direction of fuel flow as indicated on the filter. Have towels readily available in order to quickly remove any fuel leakage. Always use new hose clamps and ensure the security of the new filter by lightly pulling on each hose. Always perform maintenance outdoors or in a well-ventilated area. Do not smoke or allow any open flames in the vicinity of any maintenance activities.

CHANGING YOUR FUEL FILTER

1. Locate your fuel filter and mark the direction it is facing.
2. Clamp each side of the fuel filter to minimize any gas spills.
3. Remove the clips from each side of the fuel filter and remove the fuel filter.
4. Place the new fuel filter in the same direction as the old and place clips back into place.
5. Remove clamps.

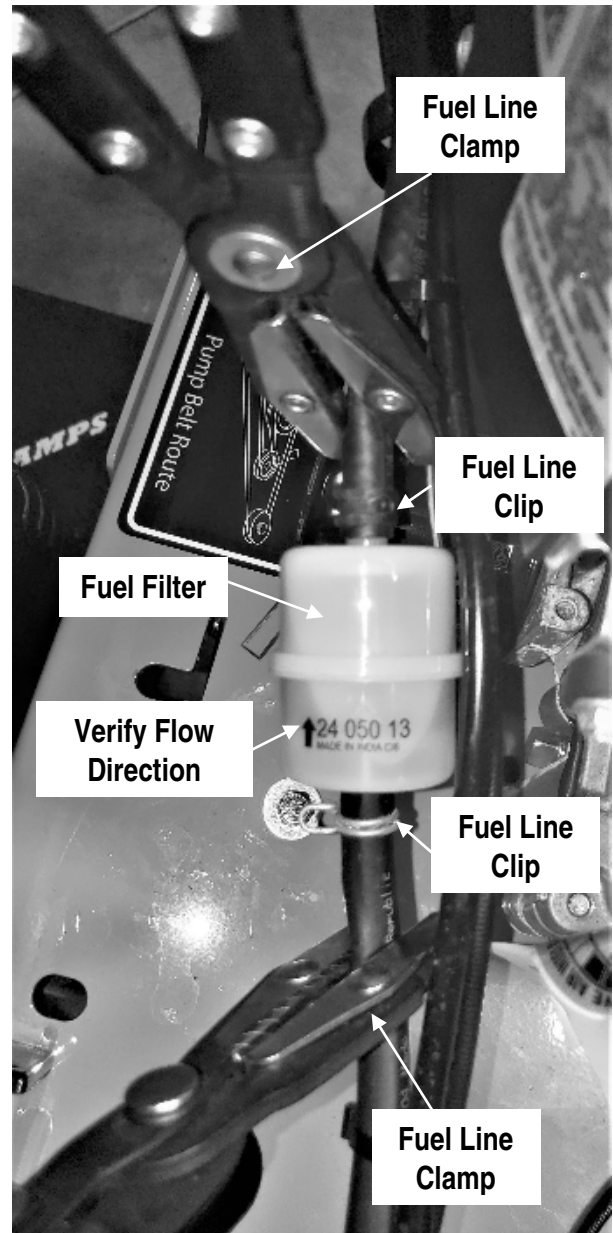



AIR CLEANER

The air cleaner is the engine's only defense against damaging foreign particles. It is very important that the air cleaner element is inspected prior to each use. Remove the element and tap its sides in order to remove debris. Do not blow the filter out using compressed air. Doing so will greatly reduce the air cleaner's effectiveness. Replace yearly; more often in dusty environments. Adhering to these practices will help prevent loss of power and premature engine failure.

CHANGING THE AIR CLEANER

1. Locate the air filter and remove the cover.
2. Remove the paper element and pre-cleaner (If applicable).
3. Replace or wash pre-cleaner in warm water with detergent. Rinse and allow to air dry (If applicable).
4. Lightly oil pre-cleaner with new engine oil; squeeze out excess oil (If applicable).
5. Replace paper element and place pre-cleaner onto new paper element.
6. Install paper element onto engine and reinstall air filter cover.

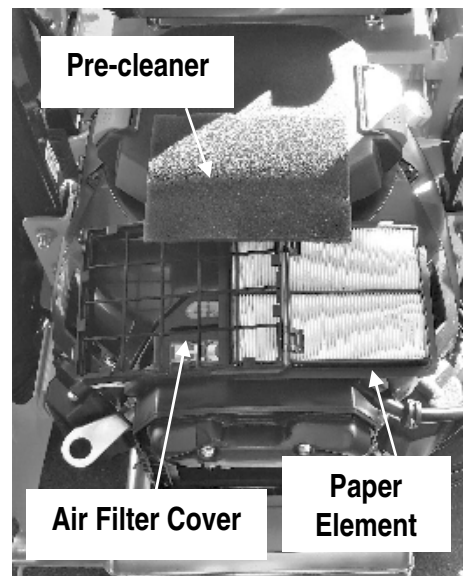
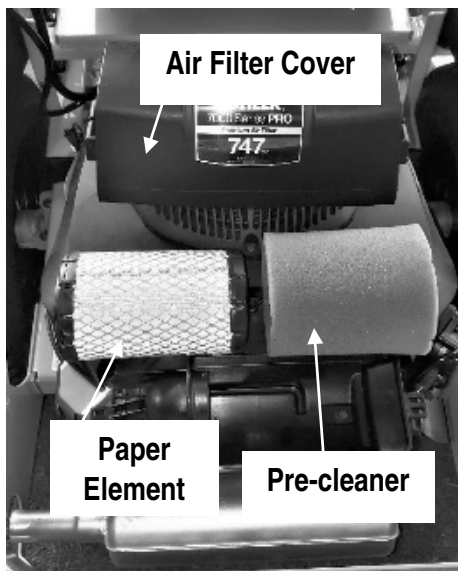
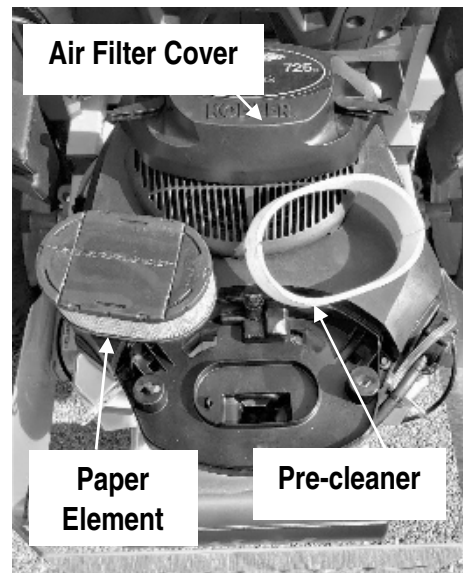
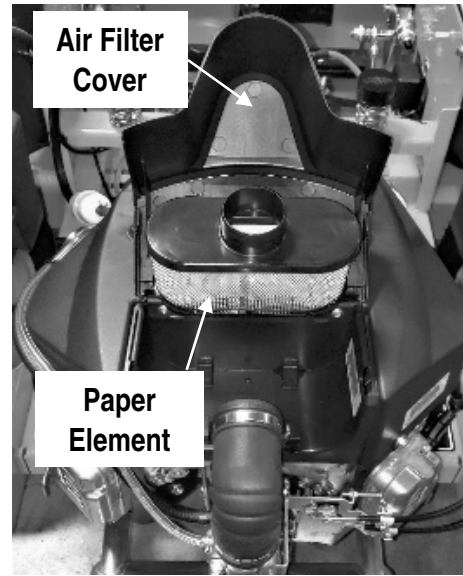



SPARK PLUG

CHANGING THE SPARK PLUGS AND CHECKING THE SPARK PLUG GAP

1. In order to access the spark plugs it is recommended to remove the rear engine cover. This can be accomplished by removing the four carriage bolts using a 1/2" ratcheting wrench.
2. Remove the wire on the spark plug and use an appropriate socket to remove the spark plug.
3. Check the gap on the spark plug to verify that it is 0.03" by using a feeler gauge.
4. If the spark plug is worn, overheated, wet or carbon fouled replace the spark plug.
5. Install the plug into cylinder head and torque to engine manufacture specifications. Be careful not to overtighten the spark plug.

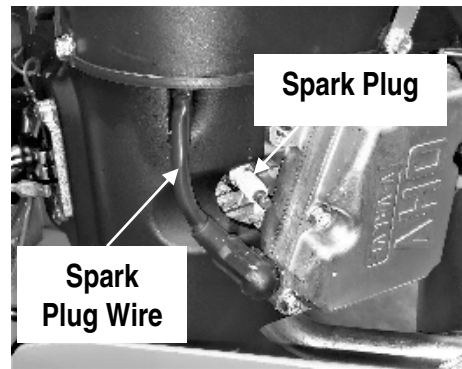
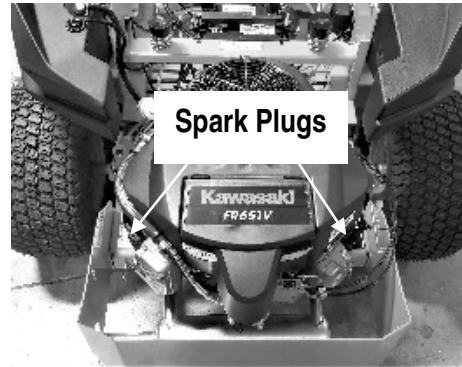
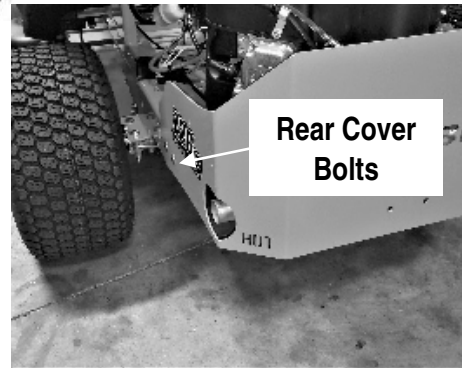

Spark Plug Component and Details

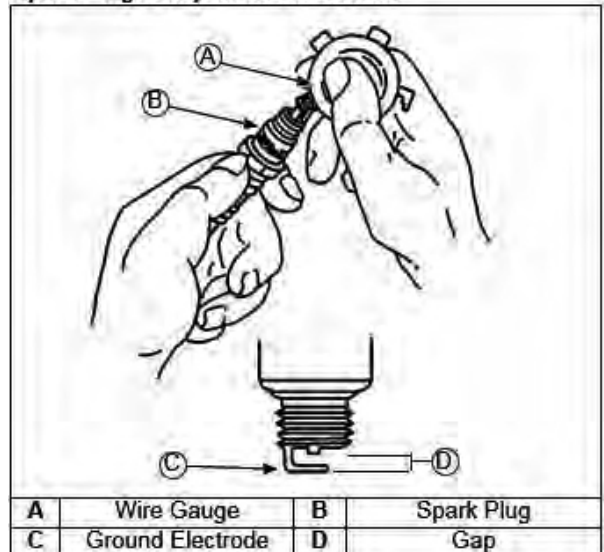



BAD BOY MOWERS

SECTION 4: ELECTRICAL SYSTEM

This mower is equipped with three protective fuses: a 25-amp main fuse (pictured to the right), a 10-amp clutch fuse (blade engagement) and a 15-amp linear actuator fuse (optional deck lift). The main fuse is located on the left side of the unit; by the starter solenoid. The clutch fuse is located just underneath the control panel along with the linear actuator fuse (if equipped).

A blown fuse usually indicates a problem within the electrical system or an electrical component. Never replace a fuse with one of a higher amperage rating or "by pass" a fuse in any way. Doing so creates a significant fire hazard and can cause severe damage to the mower's electrical components. If a fuse is repeatedly blowing, contact your Bad Boy dealer.

In order to access the clutch fuse, you will need to take off the control panel by removing four socket head screws using a 1/8" hex bit. This can be seen in the images on the right. Once you remove the screws remove the control panel and you can access the clutch fuse.

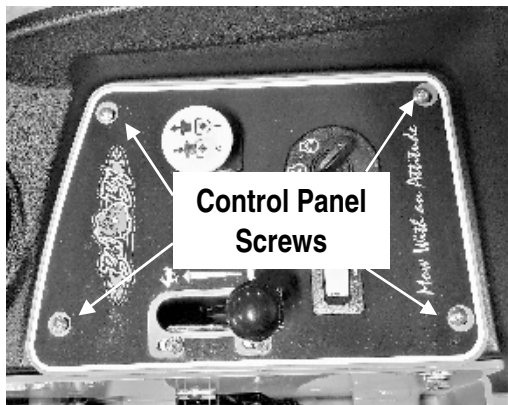
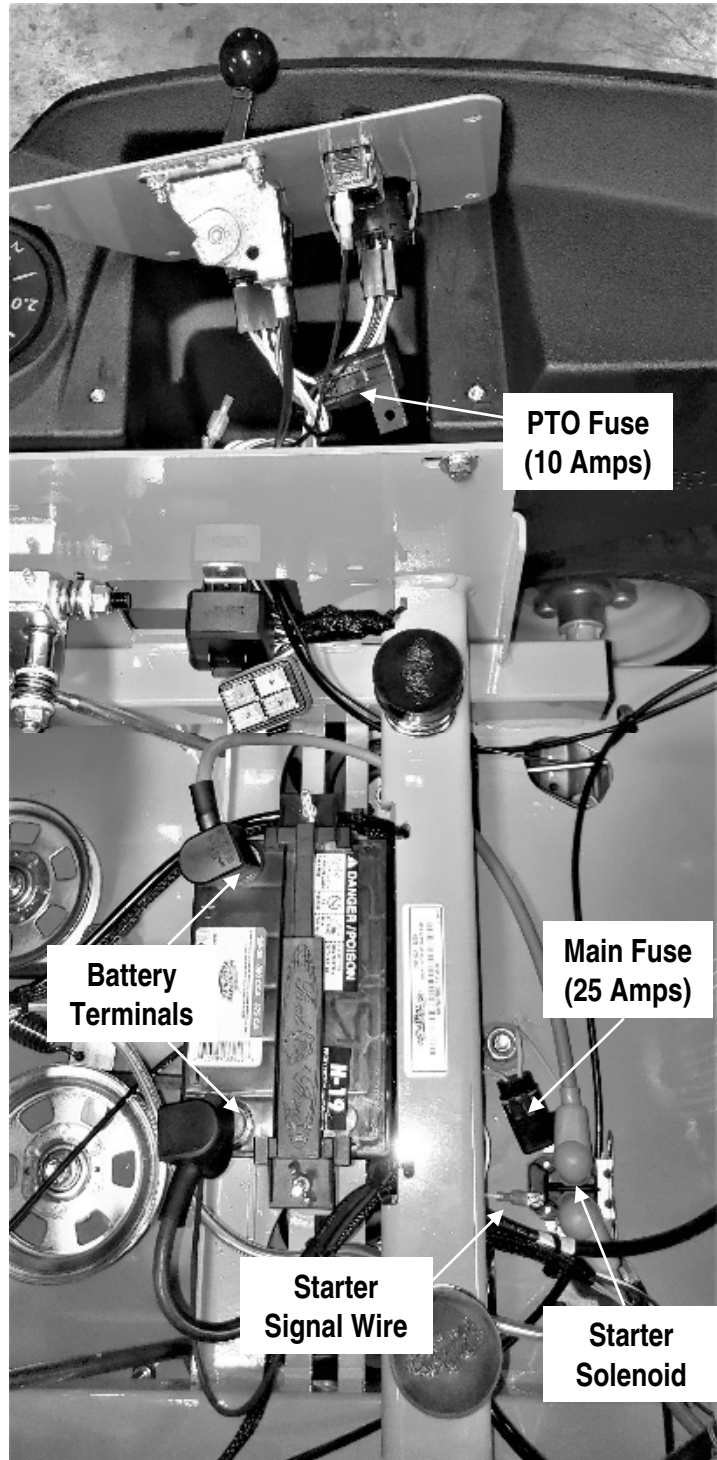



ELECTRICAL SYSTEM *(CONTINUED)*

On most models, the red wire coming out of the engine is the charging wire from the alternator. Check for 13.6 - 14.2 volts dc at this wire with engine at full throttle.

If you are having issues starting your mower ensure the signal wire is connected to your starter solenoid.

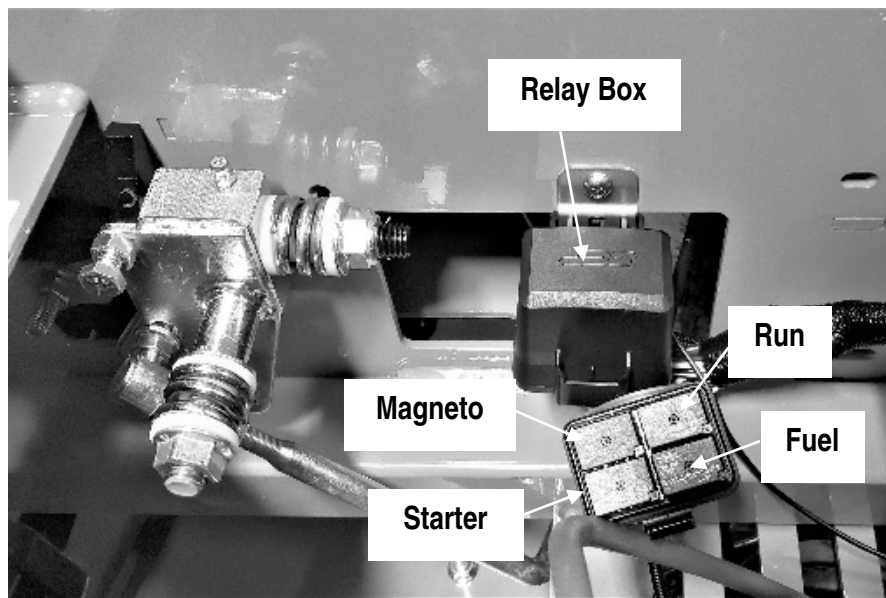

Check the condition and connection of the relays located under the seat on the right side of the frame. Ensure that they are clean and connected. Make sure that wire terminal ends have not been pushed out of the relay block.

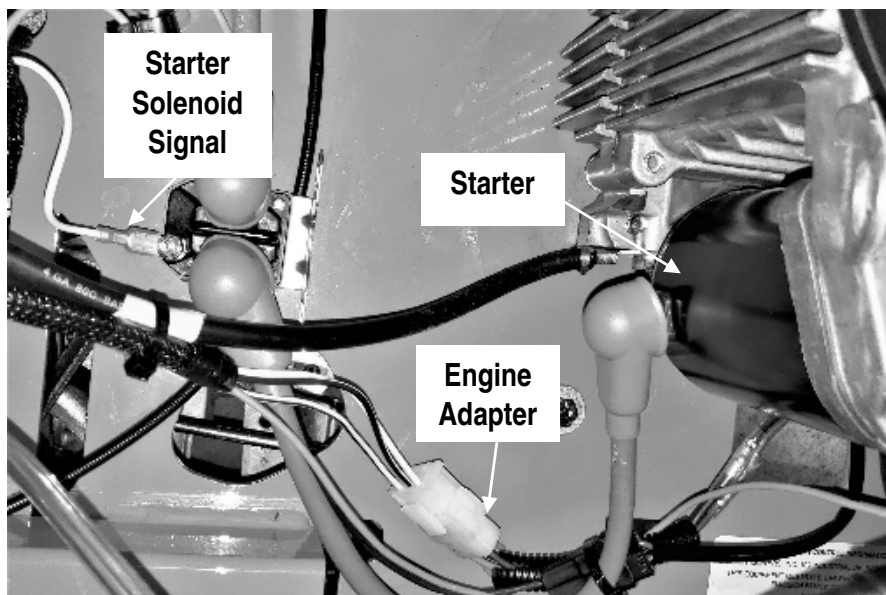



ELECTRICAL SYSTEM (CONTINUED)

WIRING DIAGRAM (For a larger version of the below diagram please visit badboymowers.com and click the parts manuals section)

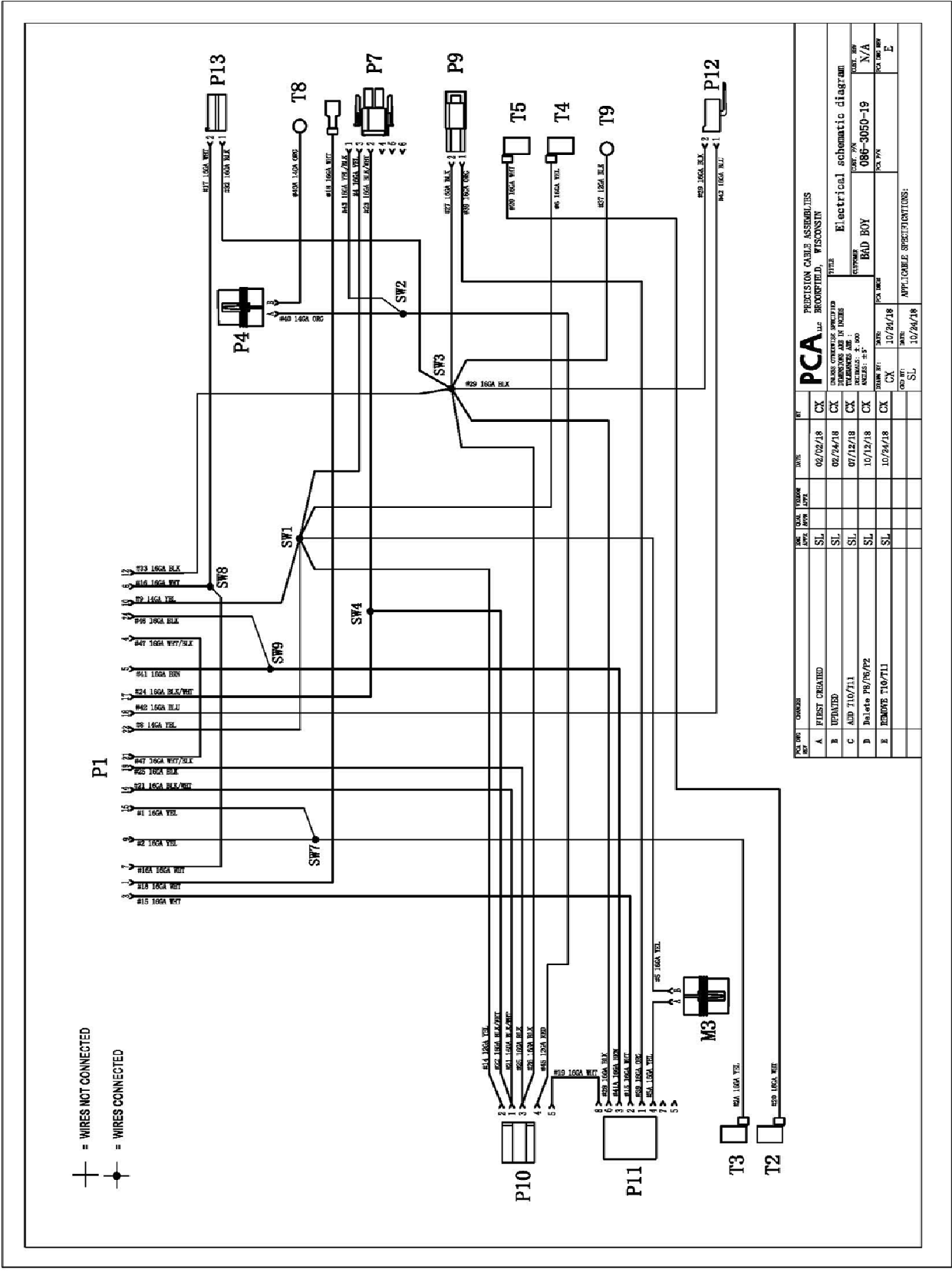

REV	DATE	DESCRIPTION	BY
A	02/02/18	FIRST CREATED	CX
B	02/04/18	UPDATED	CX
C	07/12/18	ADD T10/T11	CX
D	10/12/18	DELETE P10/P12	CX
E	10/04/18	REMOVE T10/T11	CX

DATE	10/24/18	BY	SU
TIME		BY	
DATE	10/24/18	BY	SU
TIME		BY	

PCA PRECISION CABLE ASSEMBLIES
BROOKFIELD, WISCONSIN

DATE: 02/02/18
DRAWN BY: J. HANSEN
CHECKED BY: J. HANSEN
DATE: 02/02/18
REV: 1

Electrical schematic diagram
PART NO: 086-0050-19
REV: 1

APPLICABLE SPECIFICATIONS:
SU



SECTION 5: FRAME

The front fork nuts require a torque of 40ft.-lbs. While applying this torque, turn the fork itself to ensure no damage is done to the bearing. This operation is only necessary if a repair requires it. To access the recessed front fork nuts, remove the dust cap by prying gently using a flat-head screwdriver. Once cap is removed, a 1 7/16 in socket will be needed for top nut. You will need to secure the bottom nut with a 1 1/2" wrench. Once you have torqued the nuts to 40 ft.-lbs., reapply the dust cap by gently tapping around its edges. Do NOT hit center of cap.



Torque rear wheel lugs to 65-75ft. lbs. Re-torque at every oil change and check every morning.

The pump belt tensioner is located under the engine and has a grease fitting at its pivot point. Grease at every engine oil change.

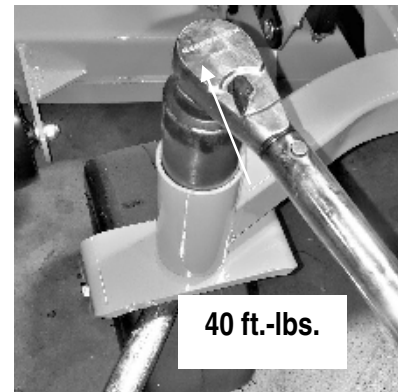

The deck belt tensioner is located at the rear of the deck and has a grease fitting on its pivot. Grease at every engine oil change.

The control arm blocks have grease fittings located on the top of each block. Grease one time a year.

There are two grease fittings located on each of the two turnbuckles (4 total). Grease at every oil change.

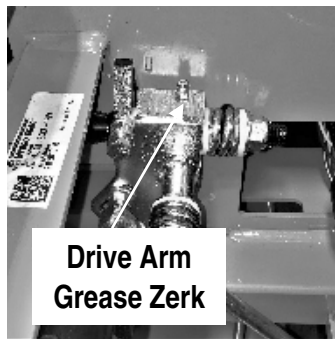



SECTION 6 : CUTTING DECK

DECK BELT REMOVAL

1. Remove ignition key.
2. Raise the deck to its highest position.
3. Remove the right pulley cover.
4. While lifting up on the belt (as shown in the photograph), rotate the pulley until the belt is free of the pulley. Exercise caution while performing this step as fingers can easily become caught between the belt and pulley.

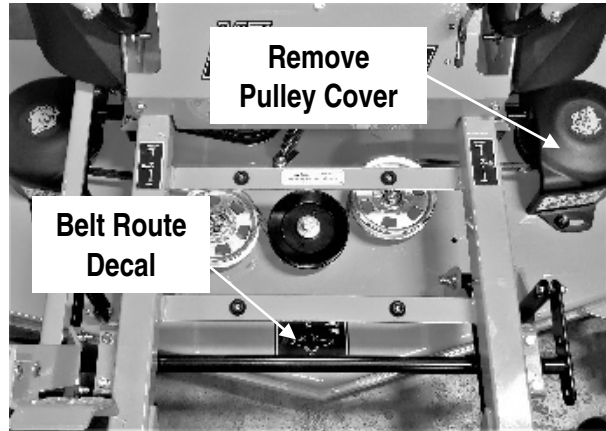

DECK BELT INSTALLATION

1. Remove ignition key.
2. Raise the deck to its highest position. If needed loosen the deck belt tensioner to its weakest installed position.
3. Take off both pulley covers and route the belt by following the belt route decal. (The easiest way to finish running the belt is routing the belt through the deck pulleys leaving it off the left deck pulley. Slip it onto the clutch then carefully slip it onto the left deck pulley.)
4. Verify that the belt is routed properly as improper routing can damage the spindles as well as the engine. Improper routing can also increase the potential of a personal injury hazard.
5. Check belt tension and adjust if needed.
6. Reinstall both pulley covers.

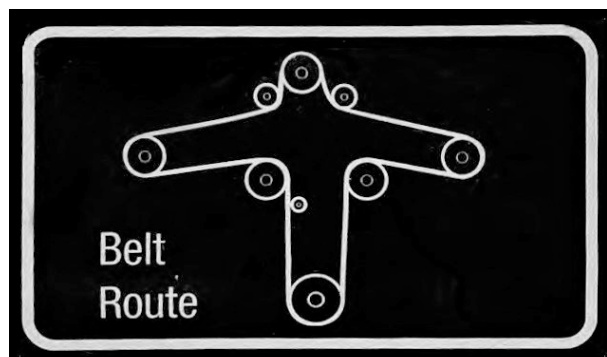
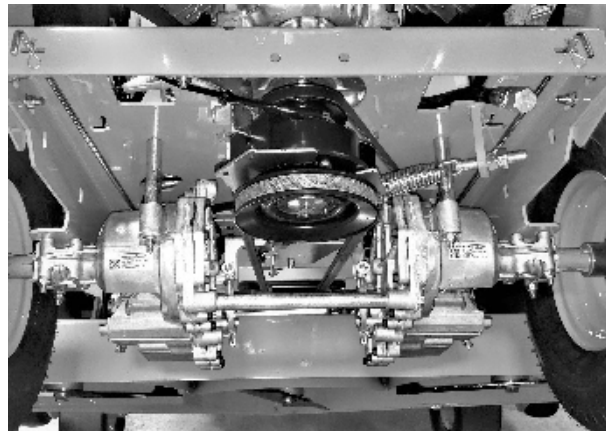



ADJUST DECK BELT TENSION

The deck spring tension is critical. If the tension is too high, premature failure of the deck belt and blade spindles can occur. If the tension is too low, the belt can "jump off" or slip on the pulleys. This results in reduced cut quality and early belt failure.

Spring tension adjustments can be made by sliding the bolt shown above forward or backward in the slot of the deck. Belt tension should be 60-65 lbs. with the deck at its lowest setting.

Use a belt tension gauge to ensure the proper tension. Your dealer or service center will have a belt tension gauge or you can buy one (Part Number 041-9999-00).

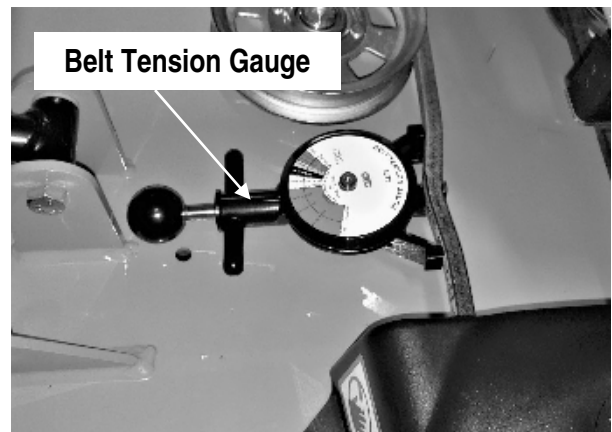
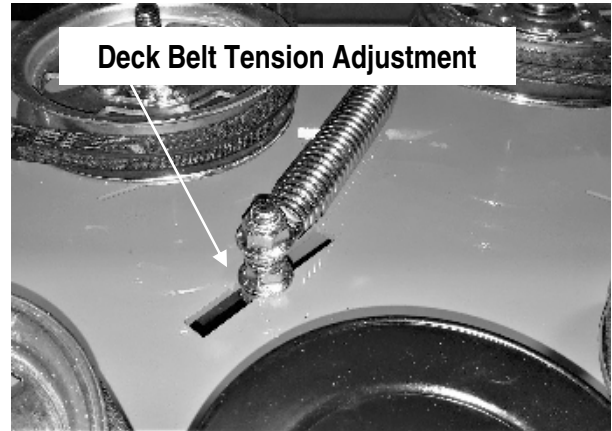

BLADE SHARPENING

The blade on the top (see photo) was utilized long after replacement was required. In addition to a decline in cut quality, failure to replace a worn or damaged blade creates a major safety hazard. Bad Boy recommends that blade sharpening be performed by a professional.

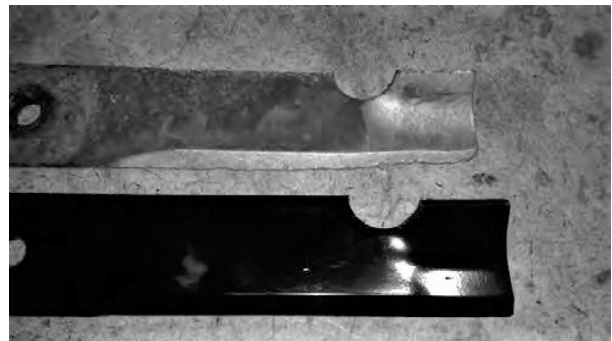



LEVELING THE DECK

Before leveling the deck, please verify linkage bar is secured properly as described in the picture to the right.

1. Start on a flat, level surface and set the air pressure in all four tires to 12 psi. Measure the deck at all four corners. The deck should be level from left to right but should be pitched downward front to back. The deck pitch is achieved by measuring from the cutting edge of the blade to the ground. Bad Boy recommends having a $\frac{1}{4}$ " pitch down in the front measured from the cutting edge of the blade. Adjustments can be made by adjusting the deck hangers in their slots.
2. Using a pair of approximately 3 ft. long 2x4's, stand the boards on edge and slide them under the deck from front to back as shown. Making sure the deck wheels and blade bolts do not rest on the 2x4's, and that the front and back edge of the deck rest on the 2x4's.
3. Lower the deck down onto the 2x4's using either the deck lift pedal or the electric actuator, whichever your mower is equipped with. The deck should now be approximately 3.5" off the ground. to achieve the proper $\frac{1}{4}$ " pitch down in the front it may be necessary to use some $\frac{1}{4}$ " spacers under the rear of the deck as shown.
4. Using a pair of $\frac{9}{16}$ " wrenches, loosen all deck hanger bolts on the top of the deck. These are the lower bolts in the slots of the deck as shown. Do not loosen the upper bolts that attach the deck hangers to the actuator lift bars.
5. The deck is now loose from the frame and movement of the lift pedal or electric actuator should only move the hanger bolts up and down in the deck slots. At this point a different deck height may be chosen on the cutting height dial. choosing a lower number will raise the decks cutting height. Choosing a higher number will decrease the decks overall cutting height. Remember, you should be approximately in the 3.5" range on your selection.
6. After setting the deck dial to the desired position, tighten all deck hanger bolts in their slots starting from the rear of the deck then moving to the front. Lift the deck to the highest position. measure all four corners of the deck again to ensure that no further adjustments are necessary.
7. Recheck belt tension before mowing.

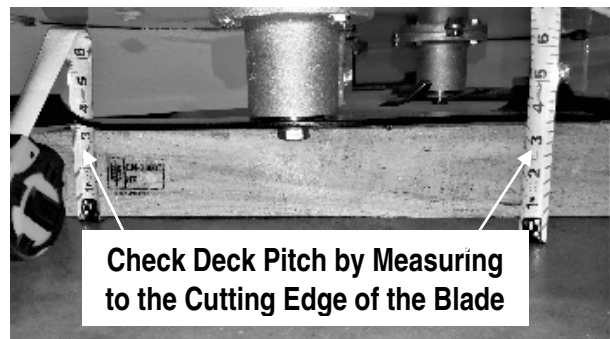
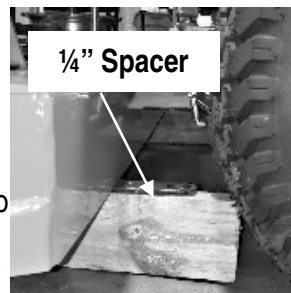
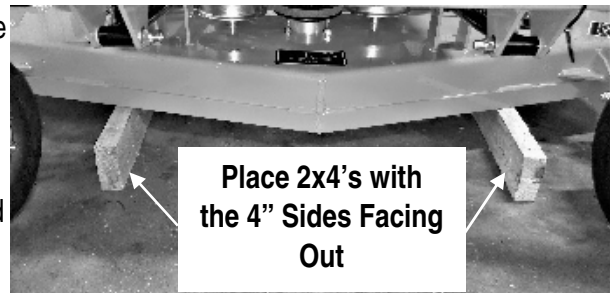
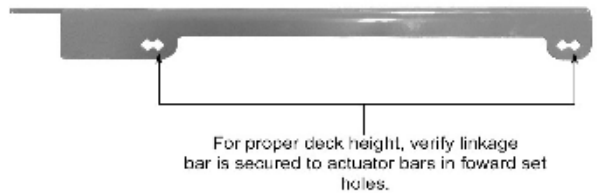



BLADEREMOVAL

To change blades, it may be best to use a piece of wood positioned between the blade and mowing deck to keep the blade from turning. Use a 15/16" socket and impact wrench capable of and output torque of at least 220 ft-lbs. A box wrench and extension can be used, though component damage potential may be increased. A 3/4" wrench can be used on the spindle shaft above the blade to keep the shaft from turning. The bolt has right-handed threads.

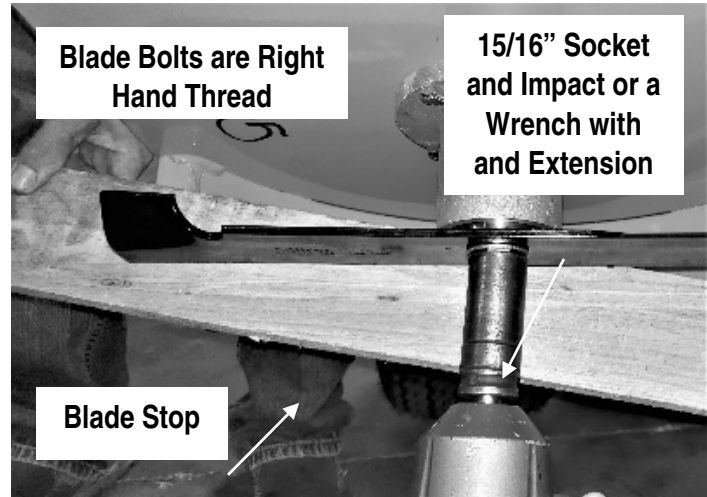

Re-torque the blade bolts to 90-110 lbs. upon re-installation.

The blade spindles contain a sealed ball bearing inside the top and bottom of the spindle. The bearings are replaceable for a more cost-effective repair. Factors such as water introduction into the bearing will have a major impact on bearing life.

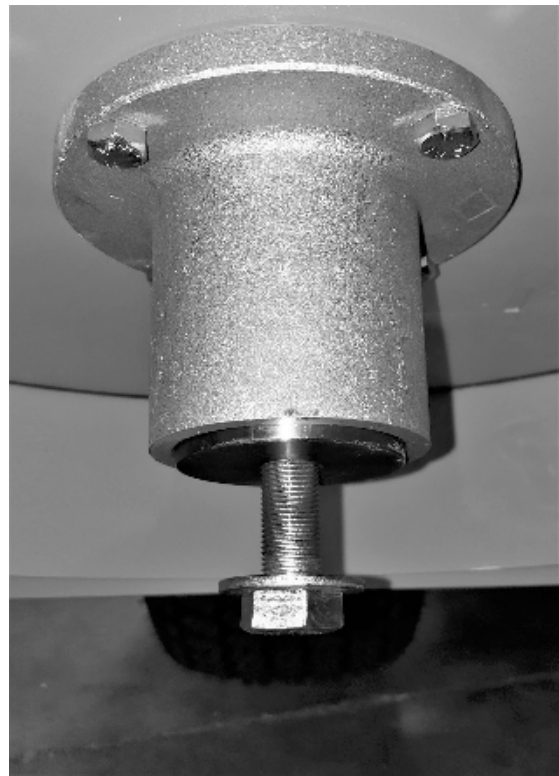



BAD BOY MOWERS

PARTS SECTION: FRONT FORK ASSEMBLY

Parts List				Parts List			
ITEM	QTY	PART NUMBER	DESCRIPTION	ITEM	QTY	PART NUMBER	DESCRIPTION
1	2	010-1050-00	Caster Bearing 2016 - 1641 Bearing	6.1	1	022-5347-00	13 x 6.50 - 6 Tire
2	1	013-8050-00	1/2-13 Nylon Flange Nut	6.2	1	022-7007-00	Front Tire Rim
3	1	013-9004-00	1" Fine Thread 1/2 Nylock Nut	6.3	2	022-7009-00	BEARING WITH RETAINER
4	1	014-2025-00	2017 Bearing Cover	7	1	023-7913-00	Front Fork
5	1	018-7010-00	1/2" x 9" GR 5 Hex Bolt	8	1	025-0003-00	2016 Front Bearing Spacer
6	1	022-2017-00	Tire and Wheel Assembly	9	1	025-5202-00	Front Wheel Spanner

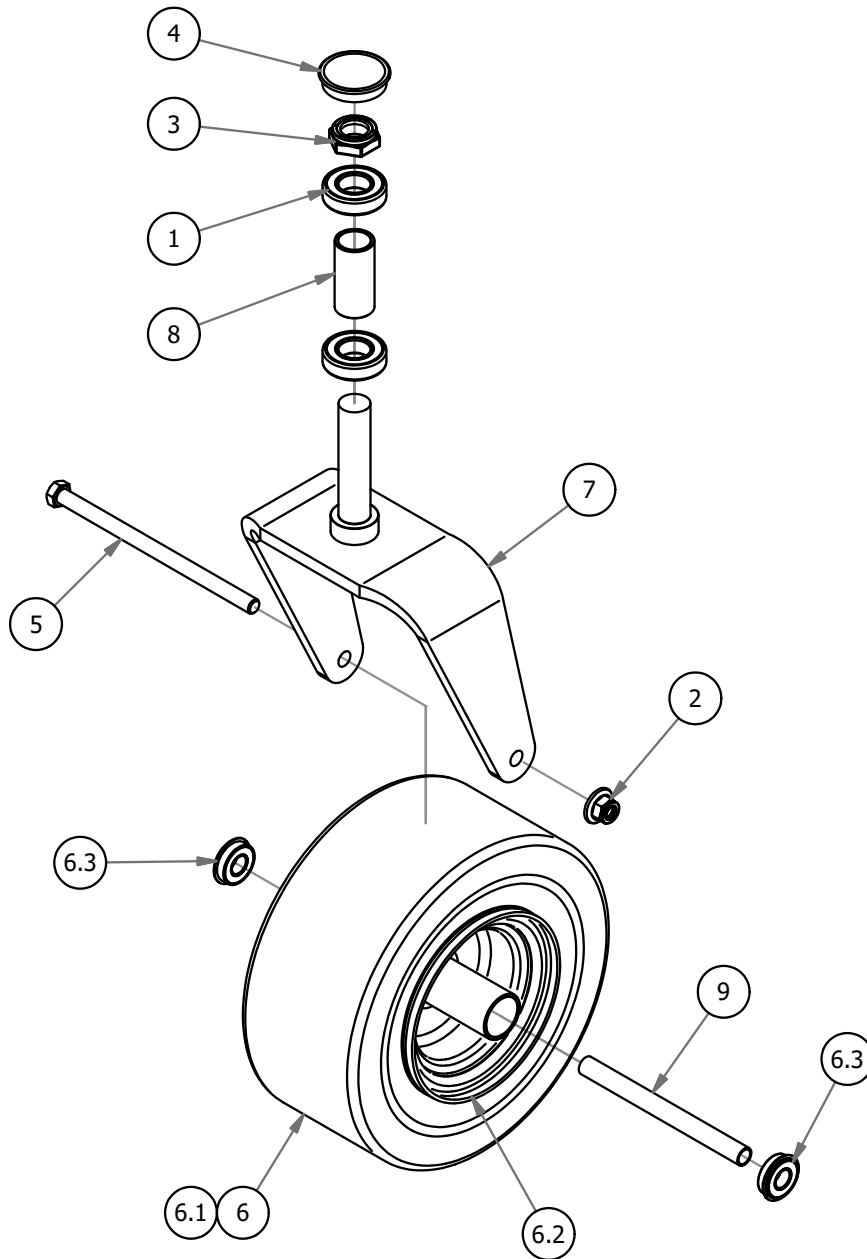



PARTS SECTION: DRIVE ARM ASSEMBLY

Parts List				Parts List			
ITEM	QTY	PART NUMBER	DESCRIPTION	ITEM	QTY	PART NUMBER	DESCRIPTION
1	2	013-0010-00	1/2-13 Mechanical Lock Nut	11	4	019-8027-00	.515 ID Nylon Shoulder Washer
2	2	013-5041-00	3/8 Nylock Nut	12	4	019-8054-00	.505 Nylon Spacer
3	2	013-6051-00	3/8" Fine Threaded Jam Nut	13	1	031-0017-03	2018 Steering Arm Assembly-Left
4	2	013-8043-00	5/16" Nut	14	1	031-0018-03	2018 Steering Arm Assembly-Right
5	2	013-9002-00	5/16" Flange Nut	15	2	034-8025-00	Drive Lever Spring
6	2	018-2050-00	10mm Damper Ball Stud-Steering	16	1	035-5450-00	Push Rod-Left
7	2	018-5040-00	3/8" x 1 1/4" Hex Bolt	17	1	035-5451-00	Push Rod-Right
8	2	018-8063-00	5/16" x 3/4" Hex Bolt	18	1	070-5490-18	2018 Maverick Frame
9	4	019-5037-00	3/8" Lock Washer	19	2	087-0001-00	Steering Damper
10	2	019-5702-00	1/2" Washer (Grade 8)				

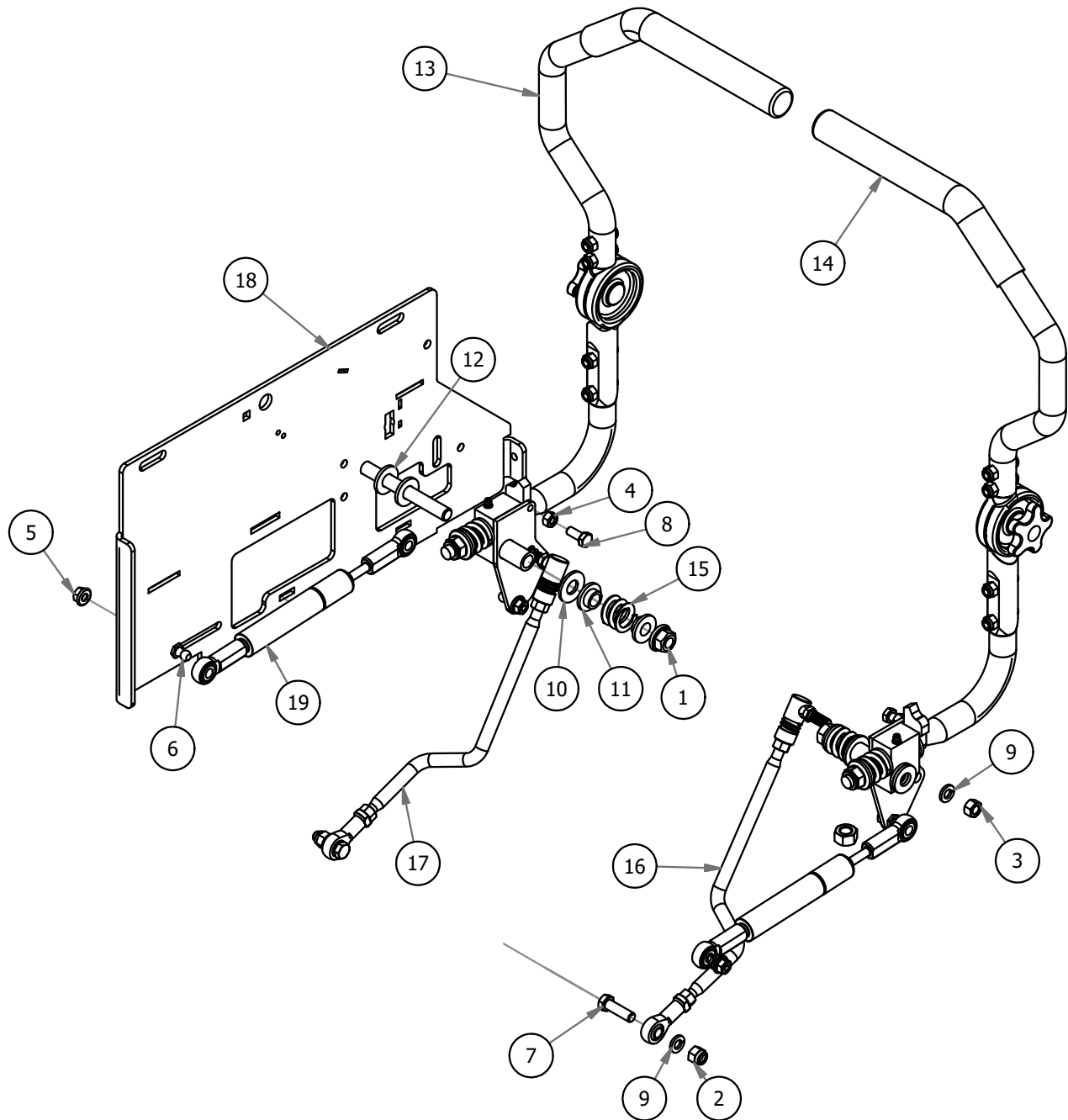



PARTS SECTION: DRIVE ARM ASSEMBLY (CONT.)

031-0017-03 Parts List				031-0018-03 Parts List			
ITEM	QTY	PART NUMBER	DESCRIPTION	ITEM	QTY	PART NUMBER	DESCRIPTION
1	1	013-8050-00	1/2-13 Nylon Flange Nut	9	1	013-8050-00	1/2-13 Nylon Flange Nut
2	1	013-9002-00	5/16" Flange Nut	10	1	013-9002-00	5/16" Flange Nut
3	1	018-2050-00	10mm Damper Ball Stud-Steering	11	1	018-2050-00	10mm Damper Ball Stud-Steering
4	2	019-8027-00	.515 ID Nylon Shoulder Washer	12	2	019-8027-00	.515 ID Nylon Shoulder Washer
5	1	019-8054-00	.505 Nylon Spacer	13	1	019-8054-00	.505 Nylon Spacer
6	1	031-0017-98	2017 Drive Lever Housing - Left	14	1	031-0018-98	2017 Drive Lever Housing - Right
7	1	031-9000-18	2018 Adjustable Steering Arm - Left	15	1	031-9050-18	2018 Adjustable Steering Arm - Right
7.1	4	013-8047-00	5/16-18 Nylock Insert Locknut	15.1	4	013-8047-00	5/16-18 Nylock Insert Locknut
7.2	4	018-2020-18	5/16-18 UNC X 1-3/8" BHCS, TORX DRIVE, GR 5	15.2	4	018-2020-18	5/16-18 UNC X 1-3/8" BHCS, TORX DRIVE, GR 5
7.3	1	018-5043-00	3/8" x 1 1/4" Carriage Bolt	15.3	1	018-5043-00	3/8" x 1 1/4" Carriage Bolt
7.4	1	031-9010-18	Upper Tube-Adjustable Steering	15.4	1	031-9010-18	Upper Tube-Adjustable Steering
7.5	1	031-9014-18	2018 Lower Adjuster - Steering Arm- Left	15.5	1	031-9015-18	2018 Lower Adjuster - Steering Arm- Right
7.6	1	031-9017-18	2018 Upper Adjuster - Steering Arm- Left	15.6	1	031-9016-18	2018 Upper Adjuster - Steering Arm- Right
7.7	1	031-9020-18	Steering Arm Elbow (Left)	15.7	1	031-9025-18	Steering Arm Elbow (Right)
7.8	1	045-5000-00	Black Knob for Adjustable Steering Arm	15.8	1	045-5000-00	Black Knob for Adjustable Steering Arm
7.9	1	069-4010-00	Rubber Grip	15.9	1	069-4010-00	Rubber Grip
8	1	034-8025-00	Drive Lever Spring	16	1	034-8025-00	Drive Lever Spring

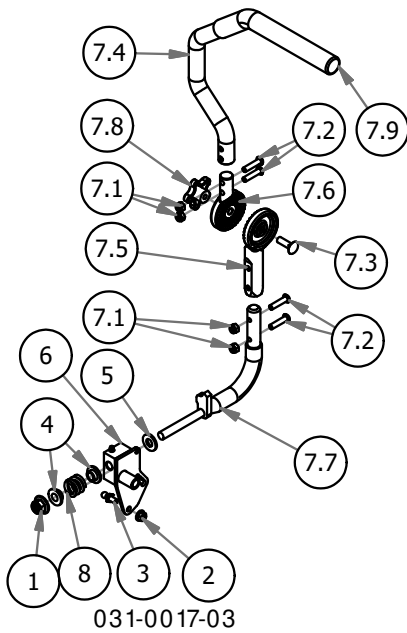

031-0017-03
2018 Steering Arm Assembly-Left

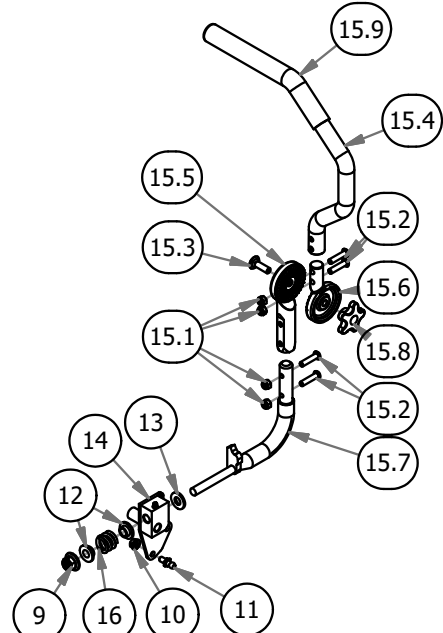

031-0018-03
2018 Steering Arm Assembly-Right

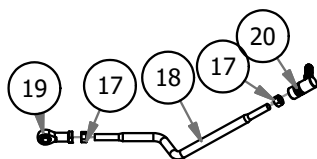

035-5451-00
Push Rod-Left

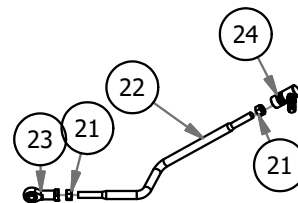

035-5450-00
Push Rod-Right

035-5451-00 Parts List				035-5450-00 Parts List			
ITEM	QTY	PART NUMBER	DESCRIPTION	ITEM	QTY	PART NUMBER	DESCRIPTION
17	2	013-6051-00	3/8" Fine Threaded Jam Nut	21	2	013-6051-00	3/8" Fine Threaded Jam Nut
18	1	035-5451-00	Push Rod - Left	22	1	035-5450-00	Push Rod - Right
19	1	048-3000-00	Spherical Rod End - Outlaw	23	1	048-3000-00	Spherical Rod End - Outlaw
20	1	099-2009-00	Quick Release Ball Joint	24	1	099-2009-00	Quick Release Ball Joint



PARTS SECTION: GAS TANK & REAR COVER ASSEMBLIES

Parts List				Parts List			
ITEM	QTY	PART NUMBER	DESCRIPTION	ITEM	QTY	PART NUMBER	DESCRIPTION
1	4	013-0005-00	1/2" Center Lock Nut	19	1	028-0008-00	Dial Rod Plunger
2	2	013-0013-00	1/2" Flat Washer Flat Black	20	1	028-0070-17	ZT Deck Height Bar Assembly
3	4	013-2050-00	1/4-20 Nylon Insert flange Nut	21	1	042-9000-00	Ignition Key
4	1	013-7018-00	1/2" Hex Nut	22	1	051-0054-00	Maverick Honda Fuel Line Assy-54"
5	4	013-8049-00	5/16-18 Nylon Flange Nut	23	1	051-2014-00	Maverick Kohler Fuel Line Assy-37"
6	1	014-2070-50	Front Cover	24	1	051-0001-00	Maverick Kawasaki Fuel Line Assy-15"
7	2	018-0024-00	M6-1.0 X 16MM Hex Bolt	25	1	067-0020-01	ZT/Mav EPA Cannister Assy
8	3	018-0031-00	5/16-18x1.5 torx cutter -Black	26	1	067-0020-63	2019 Honda Maverick EPA Cannister Assy
9	7	018-2007-00	5/16" x 1" Bolt	27	1	067-2060-50	Left Fuel Tank
10	4	018-2010-00	10-32 x 3/8" Button Socket Head Bolt	28	1	067-2070-50	Right Side Console
11	4	018-6054-00	1/2-13 x 3 1/2 GR 5 Hex Bolt	29	2	067-8090-03	Hydro Tank Assembly
12	4	018-8065-00	5/16" x 1" Carriage Bolt	30	1	070-5490-18	2018 Maverick Frame
13	2	019-6017-00	.630 ID x 1.122 OD x .142 THK Plastic Washer	31	1	077-9000-00	MZ/ZT Deck Height Dial
14	4	019-8040-00	1/4" x 3/4" Carriage Bolt	32	1	079-3460-19	2019 ZT/Maverick Control Panel Assembly
15	7	019-8044-00	5/16" Flat Washer	33	1	086-3050-19	Wiring Harness
16	7	019-8051-00	5/16" Lock Washer	34	1	089-0005-00	2016 2x2 ROPS
17	1	025-0002-00	5/8" Split Collar	35	1	201-0020-00	Honda Rectifier Mount
18	1	026-0090-00	2017 ZT Rear Plate				

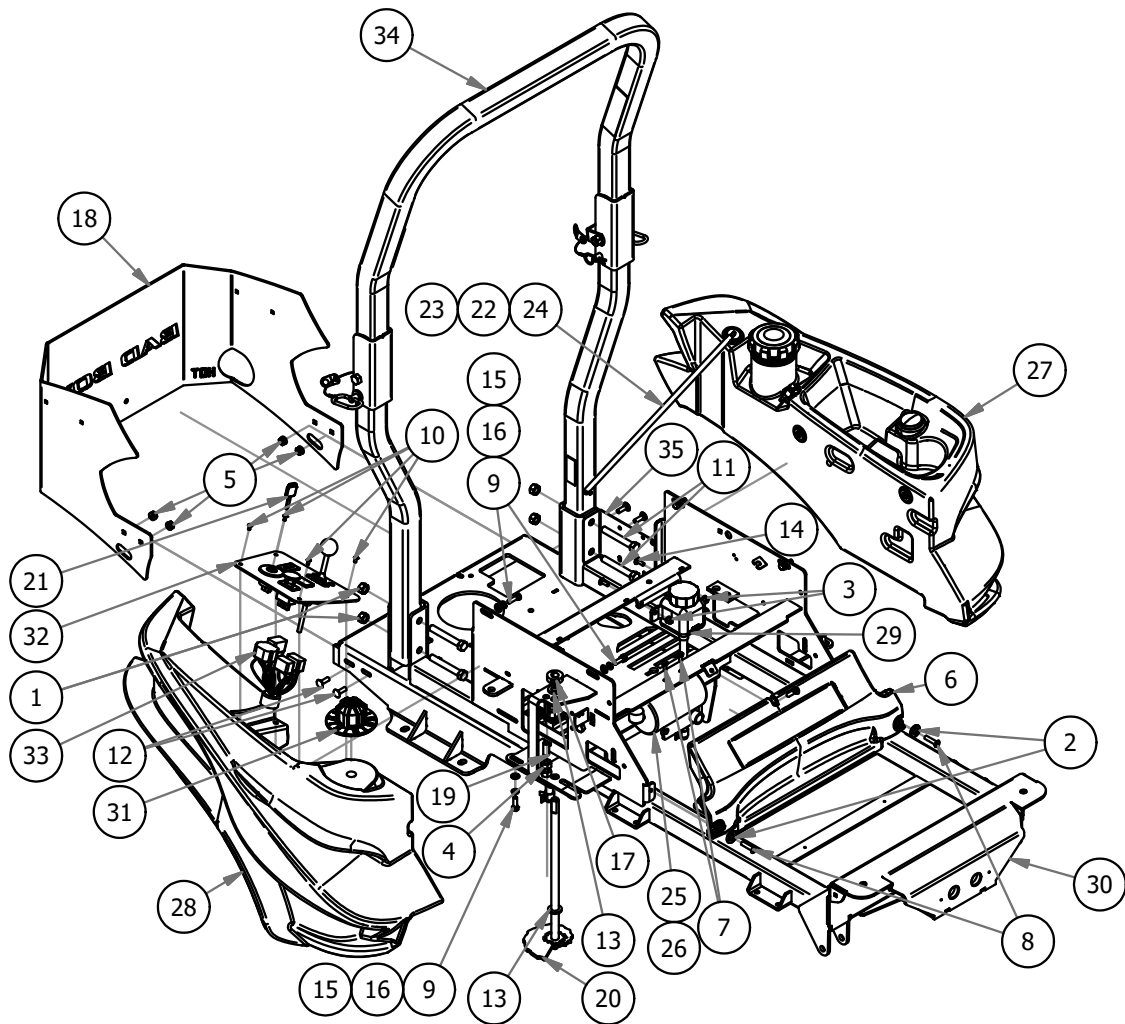



PARTS SECTION: GAS TANKS & REAR COVER ASSEMBLIES (CONT.)

028-0070-17 Parts List				067-0020-01 Parts List			
ITEM	QTY	PART NUMBER	DESCRIPTION	ITEM	QTY	PART NUMBER	DESCRIPTION
1	1	013-6051-00	3/8" Fine Threaded Jam Nut	12	1	051-2020-01	1/4" Vinyl Tubing, 46" Long
2	1	019-5029-00	3/8" Flat Washer	13	1	051-2025-02	3/16" Vinyl Tubing, 55" Long
3	1	019-5037-00	3/8" Lock Washer	14	1	067-0020-00	Carbon Canister
4	1	026-1100-00	2017 MZ/ZT Cam Plate	15	2	072-8070-00	3/16 Vinyl Clamp
5	1	028-0014-00	2017 Deck Height Dial Rod ZT	16	2	072-8073-00	3/16" Vinyl Hose Clamp
051-0054-00 Parts List				067-0020-63 Parts List			
ITEM	QTY	PART NUMBER	DESCRIPTION	ITEM	QTY	PART NUMBER	DESCRIPTION
6	4.500 ft	051-8067-00	1/4 Fuel Line, 54"	17	1	051-2020-01	1/4" Vinyl Tubing, 46" Long
7	2	072-8069-00	1/4 Fuel Hose Clamp	18	1	051-2025-02	3/16" Vinyl Tubing, 55" Long
051-2014-00 Parts List				067-0020-63 Parts List			
ITEM	QTY	PART NUMBER	DESCRIPTION	ITEM	QTY	PART NUMBER	DESCRIPTION
8	1	051-2014-01	37" 1/4 Fuel Line	19	0.300 ft	051-8065-00	3/8" PVC Tubing, 3.6" Long
9	2	072-8069-00	1/4 Fuel Hose Clamp	20	1	067-0020-00	Carbon Canister
051-0001-00 Parts List				067-0020-63 Parts List			
ITEM	QTY	PART NUMBER	DESCRIPTION	ITEM	QTY	PART NUMBER	DESCRIPTION
10	1	051-8067-00	1/4 Fuel Line	21	2	072-8068-00	5/16 Fuel Line Clamp
11	2	072-8069-00	1/4 Fuel Hose Clamp	22	2	072-8070-00	3/16 Vinyl Clamp
				23	2	072-8073-00	3/16" Vinyl Hose Clamp
				24	1	073-8071-00	3/8-1/4 Nylon Reducer

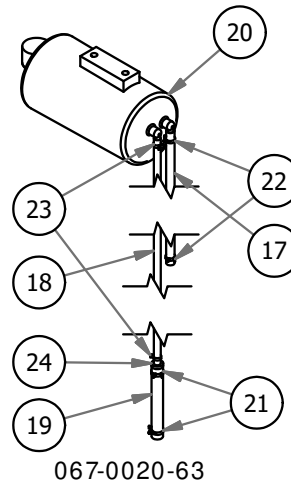
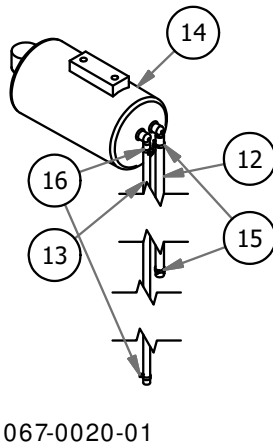
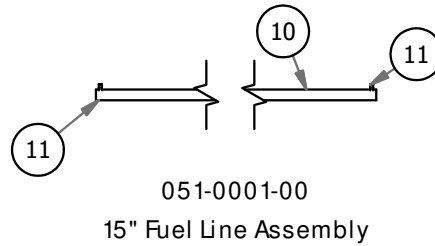
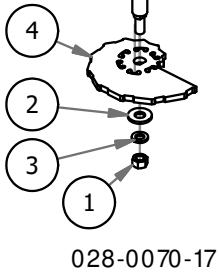
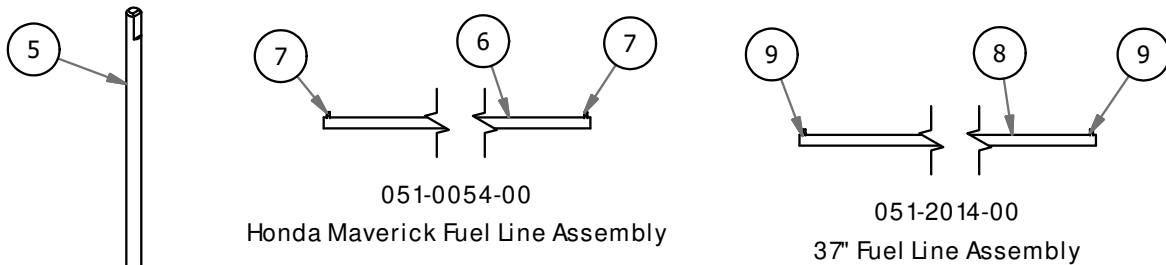



PARTS SECTION: GAS TANK & REAR COVER ASSEMBLIES (CONT.)

067-2060-50 Parts List				079-3460-98 Parts List			
ITEM	QTY	PART NUMBER	DESCRIPTION	ITEM	QTY	PART NUMBER	DESCRIPTION
25	1	066-8083-00	Fuel Cap	36	2	013-5019-00	10-24 Nylon Insert Locknut Zinc Orange Nylon
26	1	067-0011-00	Pick-Up	37	1	018-1040-00	Light Plug
27	1	067-4090-00	Fuel Gauge w/Grommet	38	2	018-5200-00	10-24 X 5/8 BS Button Head Bolt
29	1	067-6070-00	Rollover Valve W/Grommet	39	1	055-8020-00	Throttle Lever Assembly
30	1	067-6080-00	Pick-Up Grommet	40	1	056-8058-00	PTO Engager
067-8090-03 Parts List				41	1	077-8076-00	Ignition Switch
ITEM	QTY	PART NUMBER	DESCRIPTION	42	1	079-3460-00	Control Panel
31	1	051-0016-00	ZT/Maverick Hydro Tank Hose	43	1	083-4013-00	Tachometer
32	1	066-5050-00	Hydraulic Tank Cap				
33	1	067-8090-00	350ml Expansion Tank				
34	1	072-8065-00	3/8" Hose Clamp				
35	1	072-8066-00	1/2" Hose Clamp				

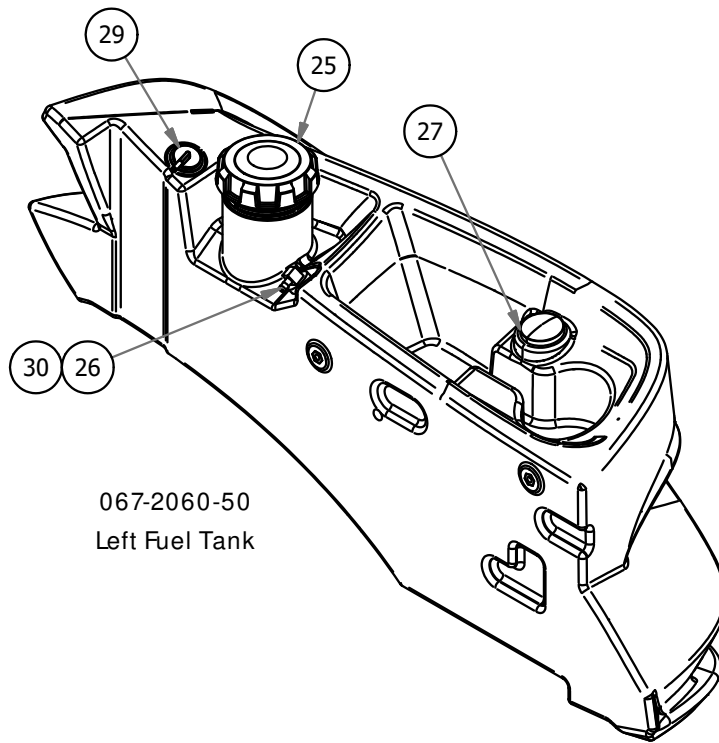

067-2060-50
Left Fuel Tank

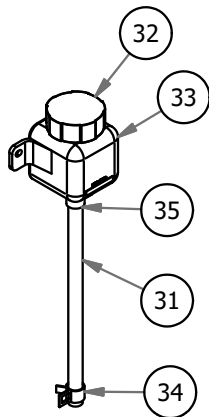

067-8090-03
Hydro Tank Assembly

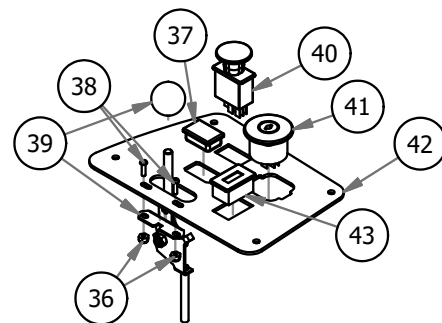

079-3460-19
2019 ZT/Maverick Control Panel Assembly



BAD BOY MOWERS

PARTS SECTION: UPPER FRAME ASSEMBLY

Parts List				Parts List			
ITEM	QTY	PART NUMBER	DESCRIPTION	ITEM	QTY	PART NUMBER	DESCRIPTION
1	8	013-8049-00	5/16" Nylock Flange Nut	20	12	040-6080-00	Ratchet Fastener
2	2	013-8073-00	1/4" Nylock Nut	21	1	043-8929-00	Hold Down Assembly
3	5	013-9001-00	1/4-20 Hex Flange Nuts Zinc w/Serrations	22	1	054-8017-00	Choke
4	1	013-9002-00	5/16" Flange Nut	23	1	064-0030-00	Ground Cable
5	2	014-8047-00	Seat Spring Cap Cover	24	1	064-3050-00	Brake Cable, 18.5"
6	2	018-1080-00	12-24x 1/2 HWH Bolt	25	1	064-3051-00	Brake Cable, 24.5"
7	1	018-2012-00	1/4" x 1/2" BS C/S 18-8 SS	26	1	064-5300-00	24" Red Battery Cable
8	4	018-8052-00	1/4" x 3/4" Hex Bolt	27	1	064-5301-00	12" Red Battery Cable (Not on Honda)
9	5	018-8066-00	5/16" x 7/8" Carriage Bolt	28	1	064-8060-00	36" Red Battery Cable (Honda Only)
10	6	019-6042-00	.360 ID Plastic Washer	29	1	068-8049-00	Battery
11	2	019-8040-00	1/4" x 3/4" Carriage Bolt	30	1	069-1050-01	2017 ZT Brake Handle Assembly
12	1	026-1016-00	Seat Plate 2016	31	1	070-5490-18	2016 Frame
13	1	028-0090-00	Seat Latch Rod Assembly	32	1	071-5080-18	2019 Maverick Seat
14	4	029-4010-00	Button Bumper	33	1	077-8073-00	Safety Switch
15	4	030-3050-00	#10 x 1/2" Self Tapping Screw	34	1	079-3470-18	2018 Maverick Floorboard
17	4	030-7042-00	5/16 x 3/4 washer head type F screw	35	1	081-4000-00	2017 MZ/ZT Floor Mat
18	2	034-1025-00	Seat Latch Spring	36	1	086-3050-19	Wiring Harness
19	2	034-8045-03	Seat Spring Assembly	37	1	108-0001-00	Solenoid (Not used on Honda)

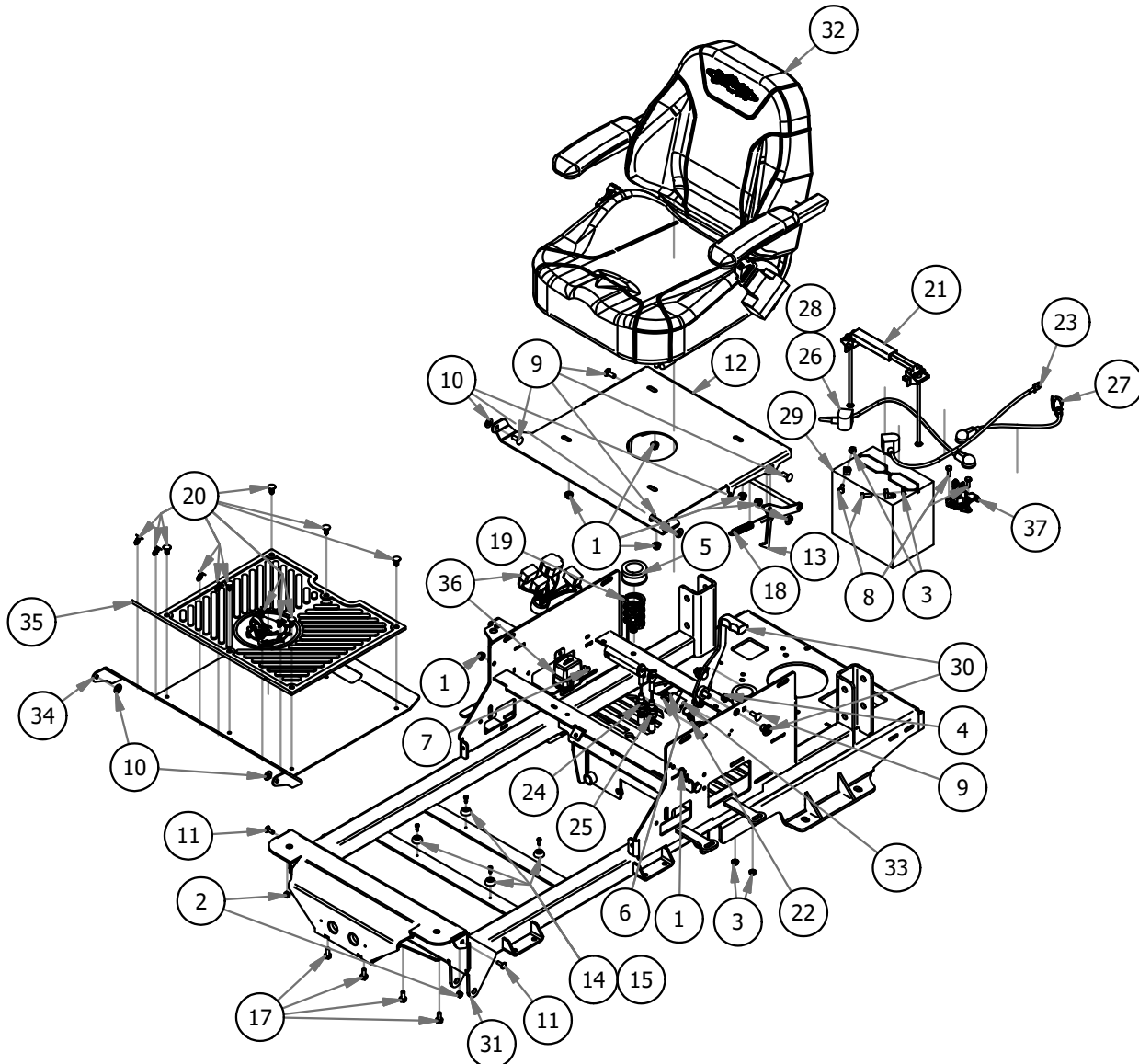



PARTS SECTION: UPPER FRAME ASSEMBLY (CONT.)

034-8045-03 Parts List				043-8929-00 Parts List			
ITEM	QTY	PART NUMBER	DESCRIPTION	ITEM	QTY	PART NUMBER	DESCRIPTION
1	1	013-0017-00	3/8-16 Half Jam Nut	18	2	013-8051-00	1/4" Wing Nut
2	1	013-5201-00	3/8" Flange Nut	19	2	018-8050-00	1/4-20 X 8 Carriage Bolt
3	1	018-3000-00	3/8"-16 x 2" Gr 5 Hex Bolt	20	1	043-8929-00	Battery Hold Down
4	1	019-5029-00	3/8" Flat Washer	071-5080-19 Parts List			
5	1	034-8045-00	Seat Spring				
069-1050-01 Parts List				086-3050-19 Parts List			
ITEM	QTY	PART NUMBER	DESCRIPTION	ITEM	QTY	PART NUMBER	DESCRIPTION
6	1	069-1050-00	Brake Handle	21	1	071-2045-00	Seat Safety Switch
7	1	013-0012-00	3/8-16 Centerlock Half Nut	22	1	071-2054-00	Seat Arm Pair
8	1	013-8042-00	5/16-18 Nylon Insert Flange Nut (Black Cap)	23	1	071-5015-00	Seat Rails
9	1	013-8049-00	5/16" Nylon Flange Nut	24	1	071-5083-00	Seat Belt
10	1	013-9002-00	5/16" Flange Nut	25	1	071-5084-00	Seat Back Cushion
11	1	018-5043-00	3/8" x 1 1/4" Carriage Bolt	26	1	071-5089-00	Seat Cushion
12	1	018-8063-00	5/16" x 3/4" Hex Bolt	086-3050-19 Parts List			
13	1	018-8065-00	5/16" x 1" Carriage Bolt	27	1	086-1202-01	Relay Block Cover Replacement Kit
14	1	019-5029-00	3/8" Flat Washer	28	4	086-1202-19	Relay
15	1	025-0001-00	2015 Brake Lever Spacer	29	1	086-3050-19	Wiring Harness (Includes Cover Replacement Kit & Relays)
16	1	032-5053-00	Bronze Bushing SF-1220-8				
17	1	039-0150-00	Brake Cable Adapter Bracket				

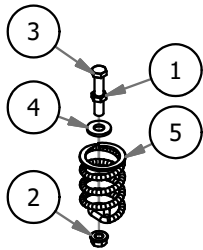

034-8045-03
Seat Spring Assembly

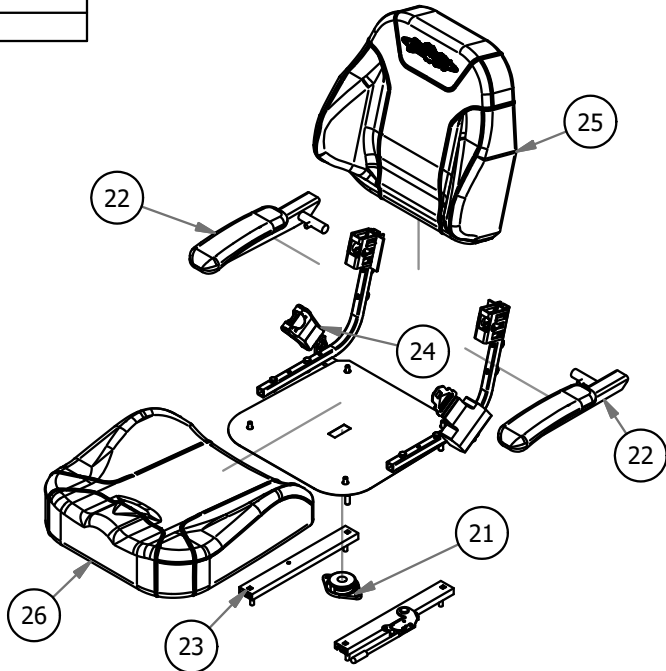

071-5080-18
2019 Maverick Seat

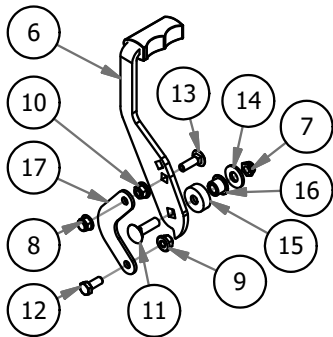

069-1050-01
2017 ZT Brake Handle Assembly

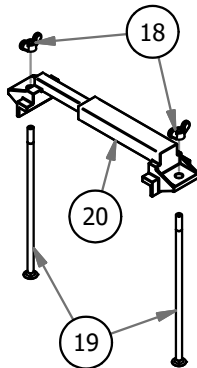

043-8929-00
Hold Down Assembly

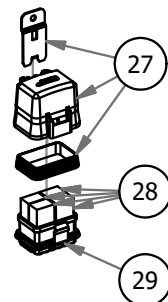

086-3050-19
Wiring Harness



BAD BOY MOWERS

PARTS SECTION: LOWER FRAME ASSEMBLY

Parts List				Parts List			
ITEM	QTY	PART NUMBER	DESCRIPTION	ITEM	QTY	PART NUMBER	DESCRIPTION
1	12	013-5202-00	3/8" Nylock Flange Nut	18	2	028-0070-00	Neutral Rod
2	2	013-6014-00	3/8" Hex Nut	19	1	029-7040-00	Front Bumper
3	2	013-7018-00	1/2" Hex Nut	20	2	030-7040-00	1/4 x 1 Hex Head Tek screw
4	2	013-9004-00	1" Fine Thread 1/2 Nylock Nut	21	1	031-0510-00	2017 MZ/ZT Actuator Linkage
5	4	017-9076-00	Pillow Block Kit	22	2	032-9002-00	Vibration Mount- Red Dot
6	2	018-0026-00	1-14 x 5.5 Hex Bolt Grade 8 Zinc Yellow	23	1	034-2020-00	Deck Idler Spring
7	8	018-0028-00	3/8-16 x 2 1/2" Hex Bolt	24	1	039-5944-05	Maverick Pump Idler
8	2	018-1055-00	1/2" x 3/4" Hex Bolt	25	2	044-2004-00	Bow Pin
9	4	018-1080-00	12-24x 1/2 HWH Bolt	26	2	044-2008-00	Neutral Rod Clip
10	1	018-2004-50	All Thread-Pump Idler Tensioner	27	2	058-1000-00	Spacer, 1x1.375x.25
11	6	018-5043-00	3/8" x 1 1/4" Carriage Bolt	28	1	070-5490-18	2018 Maverick Frame
12	2	019-5029-00	3/8" Flat Washer	29	2	077-8073-00	Safety Switch
13	2	019-5702-00	1/2" Washer (Grade 8)	30	1	250-2700-00	2018 Maverick Suspension Arm Assembly-Left Short (48" Deck Only)
14	2	019-6042-00	.360 ID Plastic Washer	31	1	250-2750-00	2018 Maverick Suspension Arm Assembly-Right Short (48" Deck Only)
15	1	026-0019-01	Foot Pedal Assembly	32	1	250-2800-98	2018 Maverick Suspension Arm Assembly-Long, Left
16	1	028-0002-00	Actuator Bar Front- 2017 MZ/ZT	33	1	250-2850-98	2018 Maverick Suspension Arm Assembly-Long, Right
17	1	028-0003-00	Actuator Bar Rear- 2017 MZ/ZT				

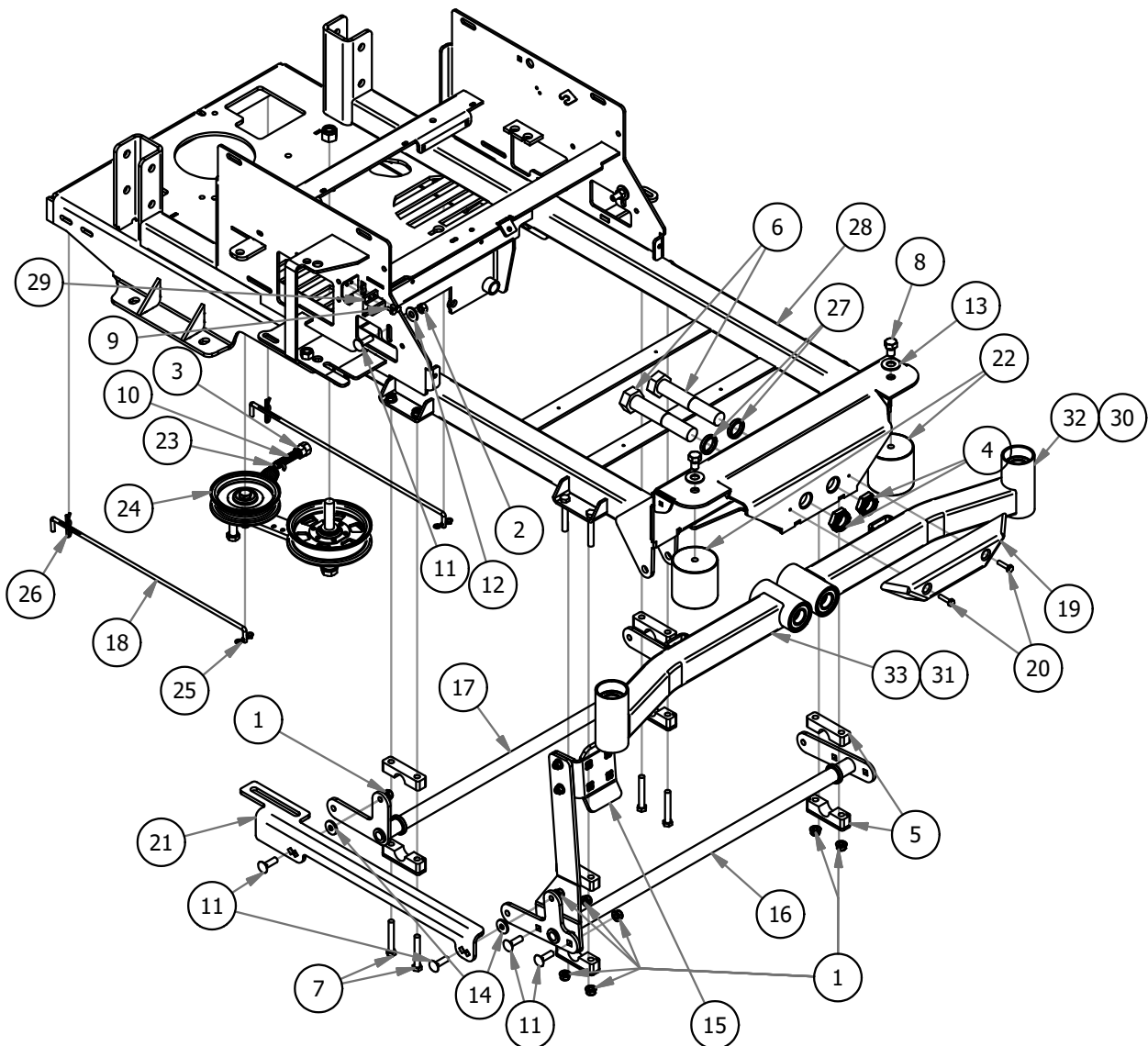



PARTS SECTION: LOWER FRAME ASSEMBLY (CONT.)

017-9076-00 Parts List				039-6944-05 Parts List			
ITEM	QTY	PART NUMBER	DESCRIPTION	ITEM	QTY	PART NUMBER	DESCRIPTION
1	1	017-9077-00	Pillow Block MZ male	8	1	013-5300-00	1/2" Flange Nut
2	1	017-9078-00	Pillow Block MZ female	9	1	013-7021-00	5/8 Std NC Nylock Nut
3	1	017-9079-00	Pillow Block Strap	10	2	013-8050-00	1/2-13 Nylon Flange Nut
026-0019-01 Parts List				11	1	018-0015-00	1/2" x 3" Hex Bolt
ITEM	QTY	PART NUMBER	DESCRIPTION	12	1	018-6016-00	5/8" x 5 1/2" Hex Bolt
4	1	031-0500-00	2017 MZ/ZT Deck Pedal Lever	13	1	018-6036-00	1/2" x 2 3/4" Hex Bolt
5	1	026-0019-00	2017 MZ/ZT Shallow Foot Pedal	14	2	019-6017-00	.630 ID Plastic Washer
6	2	013-8049-00	5/16" Nylon Flange Nut	15	1	025-5203-00	Spacer 3/4 OD x 1/2 ID x 3/4 Length
7	2	018-8065-00	5/16" x 1" Carriage Bolt	16	1	033-6001-00	4 3/4" Idler Pulley
				17	1	033-8000-00	5 3/4" Idler Pulley, 5/8 Bore
				18	1	039-6945-00	Deck Idler

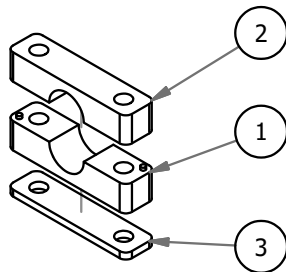

017-9076-00
Pillow Block Kit

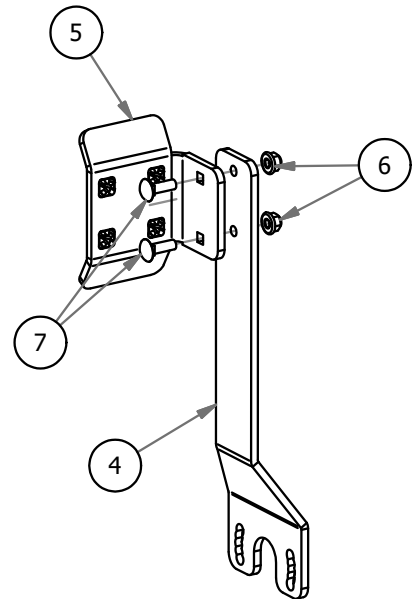

026-0019-01
Foot Pedal Assembly

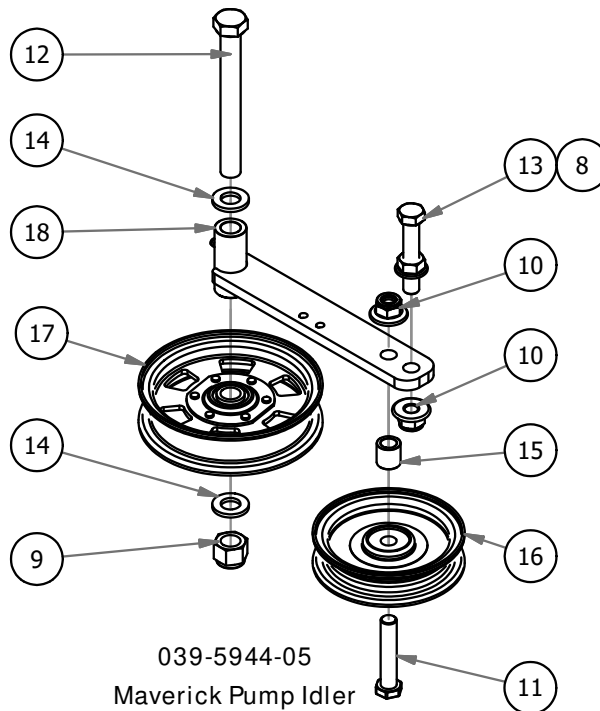

039-5944-05
Maverick Pump Idler



PARTS SECTION: LOWER FRAME ASSEMBLY (CONT.)

250-2750-98 Parts List				250-2700-98 Parts List			
ITEM	QTY	PART NUMBER	DESCRIPTION	ITEM	QTY	PART NUMBER	DESCRIPTION
1	4	010-1050-00	Caster Bearing 2016 - 1641 Bearing	9	4	010-1050-00	Caster Bearing 2016 - 1641 Bearing
2	1	014-3010-00	5/8 Round Insert	10	1	014-3010-00	5/8 Round Insert
3	2	025-0003-00	2016 Front Bearing Spacer	11	2	025-0003-00	2016 Front Bearing Spacer
4	1	250-2750-00	2018 Front Arm - Short (right)	12	1	250-2700-00	2018 Front Arm - Short (left)

250-2850-98 Parts List				250-2800-98 Parts List			
ITEM	QTY	PART NUMBER	DESCRIPTION	ITEM	QTY	PART NUMBER	DESCRIPTION
5	4	010-1050-00	Caster Bearing 2016 - 1641 Bearing	13	4	010-1050-00	Caster Bearing 2016 - 1641 Bearing
6	1	014-3010-00	5/8 Round Insert	14	1	014-3010-00	5/8 Round Insert
7	2	025-0003-00	2016 Front Bearing Spacer	15	2	025-0003-00	2016 Front Bearing Spacer
8	1	250-2850-00	2018 Maverick Suspension Arm-Long, Right	16	1	250-2800-00	2018 Maverick Suspension Arm Long-Left

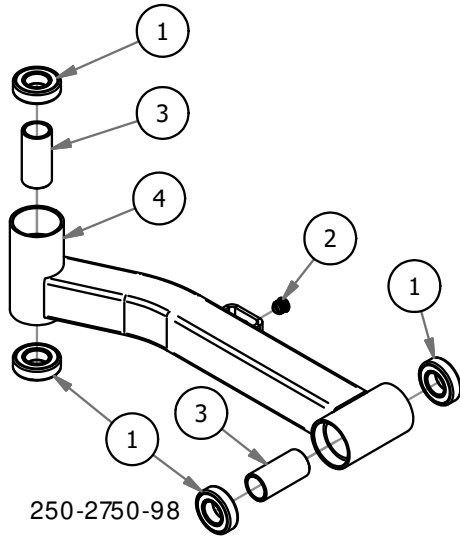

250-2750-98
2018 Front Arm Complete - Short (Right)

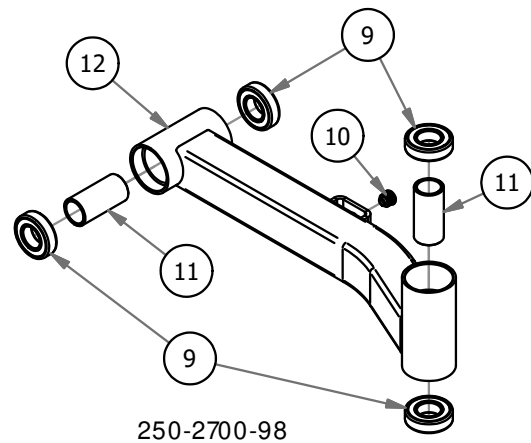

250-2700-98
2018 Front Arm Complete - Short (Left)

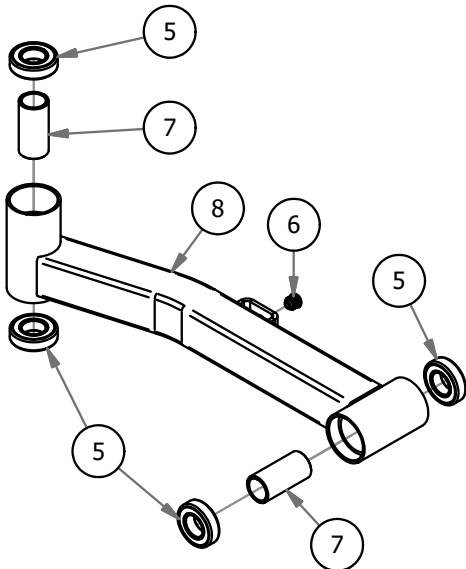

250-2850-98
2018 Maverick Suspension Arm Assembly-Long, Right

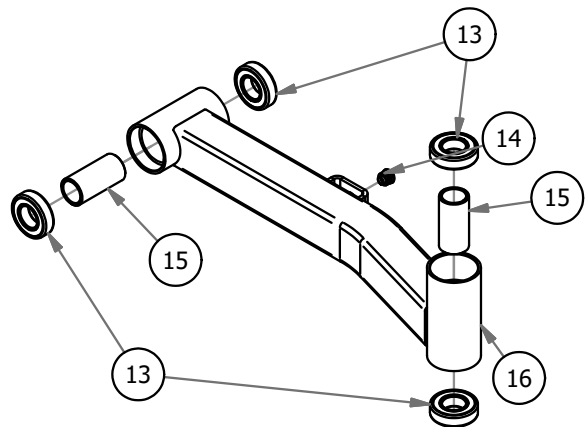

250-2800-98
2018 Maverick Suspension Arm Assembly-Long, Left



BAD BOY MOWERS

PARTS SECTION: 48" DECK ASSEMBLY

Parts List				Parts List			
ITEM	QTY	PART NUMBER	DESCRIPTION	ITEM	QTY	PART NUMBER	DESCRIPTION
1	4	013-0004-00	Acorn nut-pulley Cover	26	2	019-6017-00	.630 ID Plastic Washer
2	5	013-5201-00	3/8" Flange Nut	27	7	019-6020-00	1/2" Belleville Washer
3	2	013-5202-00	3/8" Nylock Flange Nut	28	2	019-6042-00	.360 ID Plastic Washer
4	1	013-5301-00	5/8-11 Nylon Insert Jam Half Nut	29	4	019-6050-00	.360 ID Plastic Washer-Black
5	12	013-6014-00	3/8" Hex Nut	30	8	019-8054-00	.505 Nylon Spacer
6	2	013-8049-00	5/16" Nylon Flange Nut	31	4	022-1000-00	Deck Wheel
7	13	013-8050-00	1/2-13 Nylon Flange Nut	32	2	025-5338-00	.502 ID X .750 OD X 1.500 Long Spacer
8	1	014-4025-00	pulley cover chute side	33	1	025-5339-00	1 3/4" Pulley Spacer
9	1	014-4026-00	pulley cover non-chute side	34	2	026-0024-00	42&48 Deck Spindle Support Plate
10	4	018-0010-00	Deck Wheel Bolt	35	1	026-0025-00	Deck Spindle Support Plate
11	2	018-0065-00	3/8-16 X 5-1/4 HEX CAP SCREW (GR.5) ZINC	36	3	030-0050-00	5/16 Set Screw
12	1	018-1050-00	1/2 x 2" Carriage Bolt	37	2	033-6001-00	4 3/4 Idler Pulley - ABFI-76
13	2	018-2007-00	5/16-18 x 1 GR 5 Hex Bolt Zinc	38	3	033-6003-00	5" Spindle Deck Pulley
14	2	018-2018-00	1/2 x 3 1/2 Flange Bolt Grade 8	39	1	033-7201-25	5-3/4 Idler Pulley
15	1	018-5019-00	1/2" x 4" Bolt (Grade 8)	40	1	034-2020-00	Deck Idler Spring
16	3	018-5250-00	3/8" x 3/4" Hex Bolt	41	3	037-6015-50	Spindle Assembly
17	1	018-5311-00	5/8" x 4" Hex Bolt	42	3	038-5350-00	16 1/4" Bad Boy Blade
18	12	018-6012-00	3/8 x 1.5" Bolt	43	4	039-2127-17	Deck Hanger Assembly
19	3	018-6019-00	1/2"-20 x 1 1/2 - Grade 5 Fine Thread Bolt	44	1	039-6945-18	2017 54"/48" Deck Idler Assembly
20	3	018-6020-00	5/8 x 1 1/2 Grade 8 Hex Bolt (Fine)	45	1	041-1470-00	B147 Deck Belt
21	4	018-6054-00	1/2-13 x 3 1/2 GR 5 Hex Bolt	46	3	042-6030-00	1/4" x 1" Key
22	1	019-0007-00	.517 Square Hole Round Washer	47	2	048-6000-00	2018 Maverick Turnbuckle (Top Link)
23	3	019-5007-00	1/2" Lock Washer Zinc	48	1	060-4817-00	2017 48" ZT Deck
24	12	019-5037-00	3/8" Lock Washer	49	1	206-6017-00	Discharge Chute Hanger (deck mounted)
25	3	019-5038-00	5/8" Flat Washer	50	1	210-6005-48	ZT Chute Assembly

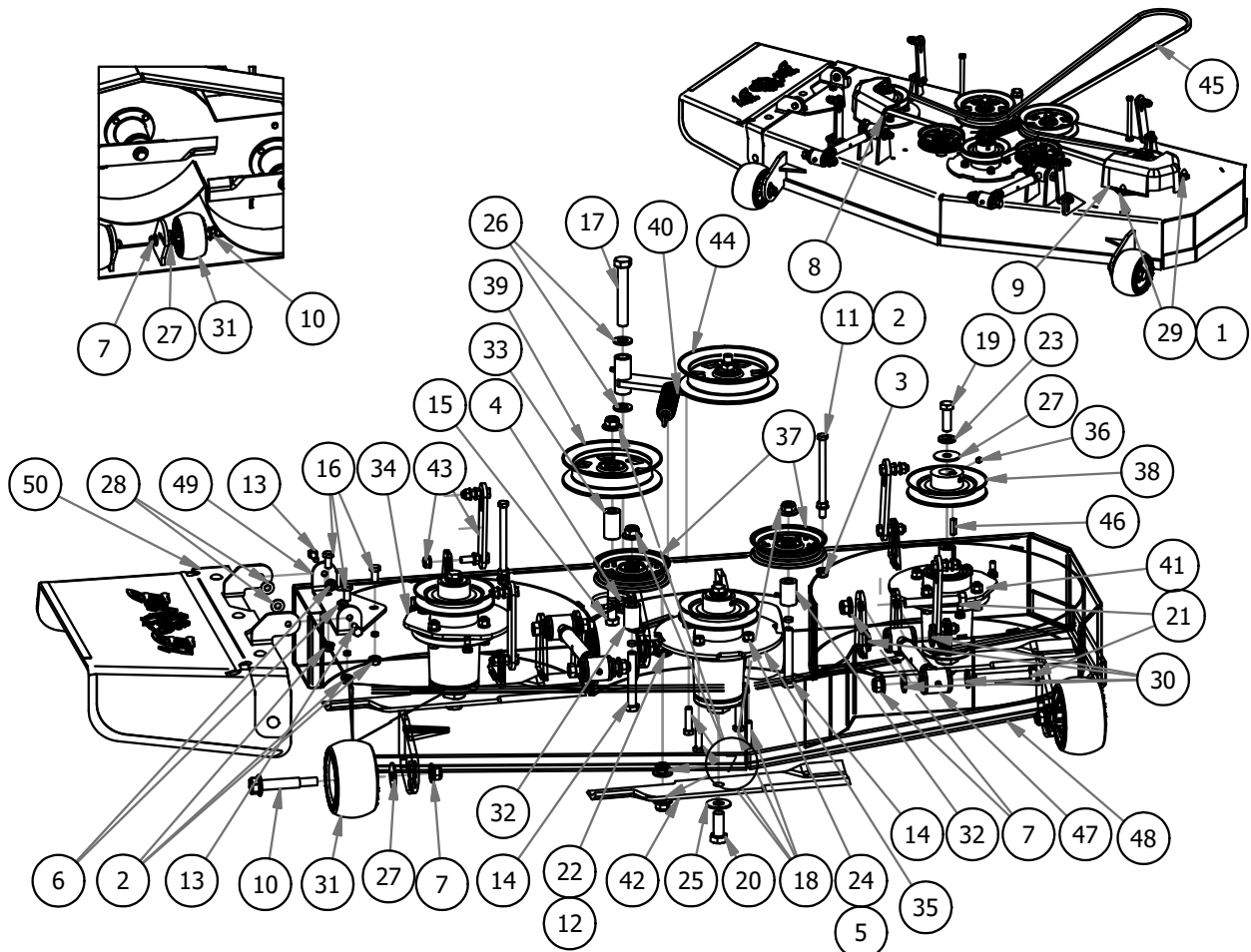



PARTS SECTION: 54" DECK ASSEMBLY

Parts List				Parts List			
ITEM	QTY	PART NUMBER	DESCRIPTION	ITEM	QTY	PART NUMBER	DESCRIPTION
1	4	013-0004-00	Acorn nut-pulley Cover	25	2	019-6017-00	.630 ID Plastic Washer
2	5	013-5201-00	3/8" Flange Nut	26	9	019-6020-00	1/2" Belleville Washer
3	2	013-5202-00	3/8" Nylock Flange Nut	27	2	019-6042-00	.360 ID Plastic Washer
4	1	013-5301-00	5/8-11 Nylon Insert Jam Half Nut	28	4	019-6050-00	.360 ID Plastic Washer-Black
5	12	013-6014-00	3/8" Hex Nut	29	8	019-8054-00	.505 Nylon Spacer
6	2	013-8049-00	5/16" Nylon Flange Nut	30	6	022-1000-00	Deck Wheel
7	15	013-8050-00	1/2-13 Nylon Flange Nut	31	2	025-5338-00	.502 ID X .750 OD X 1.500 Long Spacer
8	2	014-4000-00	Pulley Cover	32	1	025-5339-00	1 3/4" Pulley Spacer
9	6	018-0010-00	Deck Wheel Bolt	33	3	026-0025-00	Deck Spindle Support Plate
10	2	018-0065-00	3/8-16 X 5-1/4 HEX CAP SCREW (GR.5) ZINC	34	3	030-0050-00	5/16 Set Screw
11	1	018-1050-00	1/2 x 2" Carriage Bolt	35	3	033-6006-00	5.25" Deck Spindle Pulley
12	2	018-2007-00	5/16-18 x 1 GR 5 Hex Bolt Zinc	36	3	033-7201-25	5-3/4 Idler Pulley
13	2	018-2018-00	1/2 x 3 1/2 Flange Bolt Grade 8	37	1	034-2020-00	Deck Idler Spring
14	1	018-5019-00	1/2" x 4" Bolt (Grade 8)	38	3	037-6015-50	Spindle Assembly
15	3	018-5250-00	3/8" x 3/4" Hex Bolt	39	3	038-0001-00	54" Deck Fusion Blade For Outlaw
16	1	018-5311-00	5/8" x 4" Hex Bolt	40	4	039-2127-17	Deck Hanger Assembly
17	12	018-6012-00	3/8 x 1.5" Bolt	41	1	039-6945-18	2017 54"/48" Deck Idler Assembly
18	3	018-6019-00	1/2"-20 x 1 1/2 - Grade 5 Fine Thread Bolt	42	1	041-1560-00	B155.75 Deck Belt
19	3	018-6020-00	5/8" x 1 1/2" Grade 8 Hex Bolt (Fine)	43	3	042-6030-00	1/4" x 1" Key
20	4	018-6054-00	1/2-13 x 3 1/2 GR 5 Hex Bolt	44	2	048-6000-00	2018 Maverick Turnbuckle (Top Link)
21	1	019-0007-00	.517 Square Hole Round Washer	45	1	060-5417-00	54 ZT Welded Deck
22	3	019-5007-00	1/2" Lock Washer	46	1	206-6017-00	Discharge Chute Hanger (deck mounted)
23	12	019-5037-00	3/8" Lock Washer	47	1	210-6005-98	Discharge Chute Assembly
24	3	019-5038-00	5/8" Flat Washer				

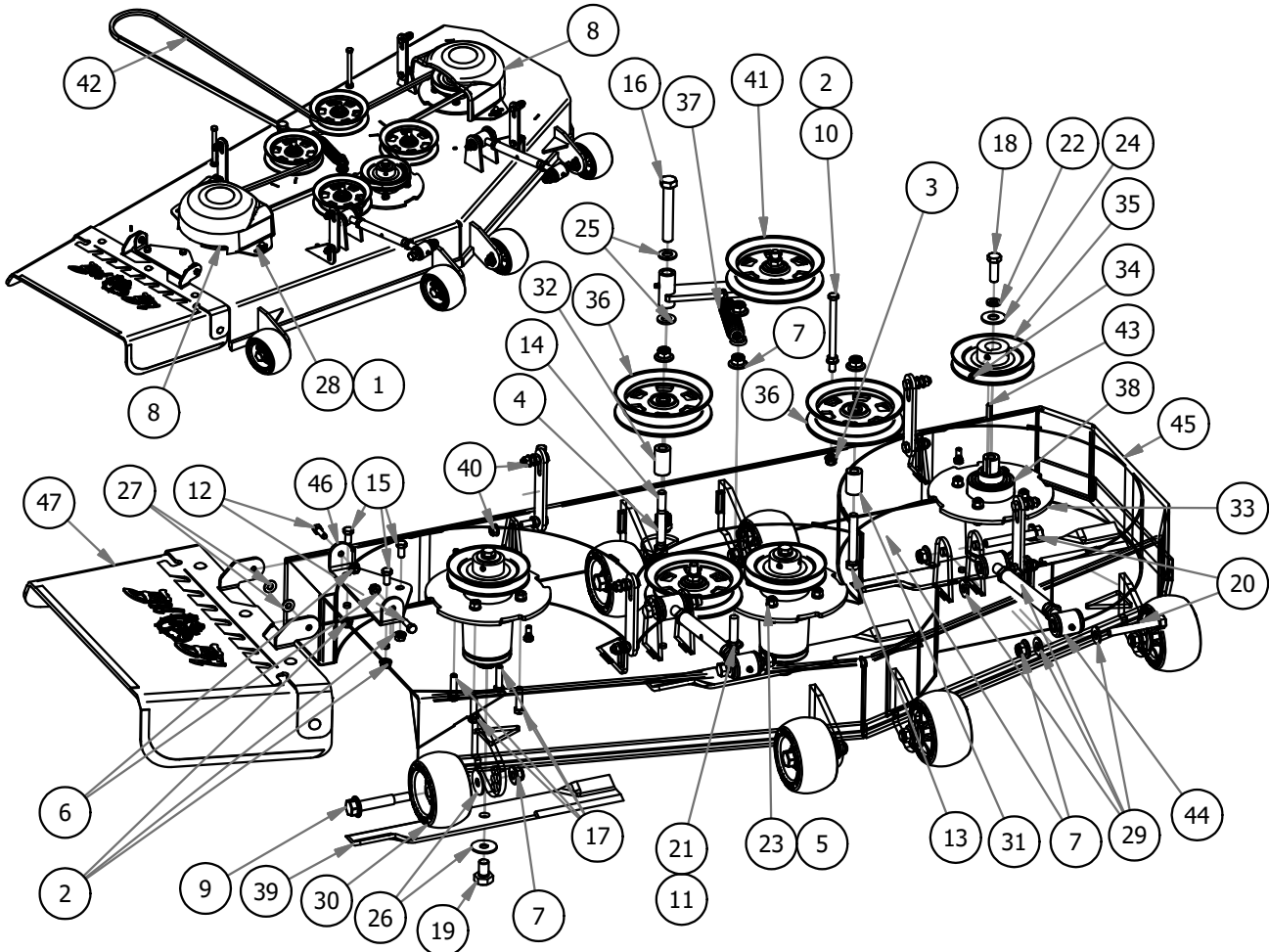



BAD BOY MOWERS

PARTS SECTION: 60" DECK ASSEMBLY

Parts List				Parts List			
ITEM	QTY	PART NUMBER	DESCRIPTION	ITEM	QTY	PART NUMBER	DESCRIPTION
1	4	013-0004-00	Acorn nut-pulley Cover	25	2	019-6017-00	.630 ID Plastic Washer
2	5	013-5201-00	3/8" Flange Nut	26	9	019-6020-00	1/2" Belleville Washer
3	2	013-5202-00	3/8" Nylock Flange Nut	27	2	019-6042-00	.360 ID Plastic Washer
4	1	013-5301-00	5/8-11 Nylon Insert Jam Half Nut	28	4	019-6050-00	.360 ID Plastic Washer-Black
5	12	013-6014-00	3/8" Hex Nut	29	8	019-8054-00	.505 Nylon Spacer
6	2	013-8049-00	5/16" Nylon Flange Nut	30	6	022-1000-00	Deck Wheel
7	15	013-8050-00	1/2-13 Nylon Flange Nut	31	2	025-5338-00	.502 ID X .750 OD X 1.500 Long Spacer
8	2	014-5000-00	Pulley Cover	32	1	025-5339-00	1 3/4" Pulley Spacer
9	6	018-0010-00	Deck Wheel Bolt	33	3	026-0025-00	Deck Spindle Support Plate
10	2	018-0065-00	3/8-16 X 5-1/4 HEX CAP SCREW (GR.5) ZINC	34	3	030-0050-00	5/16 Set Screw
11	1	018-1050-00	1/2 x 2" Carriage Bolt	35	3	033-6004-00	6 1/4" Drive Pulley
12	2	018-2007-00	5/16-18 x 1 GR 5 Hex Bolt Zinc	36	3	033-7201-25	5-3/4 Idler Pulley
13	2	018-2018-00	1/2 x 3 1/2 Flange Bolt Grade 8	37	1	034-2020-00	Deck Idler Spring
14	1	018-5019-00	1/2" x 4" Bolt (Grade 8)	38	3	037-6015-50	Spindle Assembly
15	3	018-5250-00	3/8" x 3/4" Hex Bolt	39	3	038-6060-00	60 Inch Fusion Blade
16	1	018-5311-00	5/8" x 4" Hex Bolt	40	4	039-2127-17	Deck Hanger Assembly
17	12	018-6012-00	3/8 x 1.5" Bolt	41	1	039-6945-17	2017 MZ/ZT Deck Idler Assembly
18	3	018-6019-00	1/2"-20 x 1 1/2 - Grade 5 Fine Thread Bolt	42	1	041-1650-00	B165 Belt
19	3	018-6020-00	5/8 x 1 1/2 Grade 8 Hex Bolt (Fine)	43	3	042-6030-00	1/4" x 1" Key
20	4	018-6054-00	1/2-13 x 3 1/2 GR 5 Hex Bolt	44	2	048-6000-00	2018 Maverick Turnbuckle (Top Link)
21	1	019-0007-00	.517 Square Hole Round Washer	45	1	060-6017-00	60 ZT Welded Deck Shell
22	3	019-5007-00	1/2" Lock Washer Zinc	46	1	206-6017-00	Discharge Chute Hanger (deck mounted)
23	12	019-5037-00	3/8" Lock Washer	47	1	210-6005-98	Discharge Chute Assembly
24	3	019-5038-00	5/8" Flat Washer				

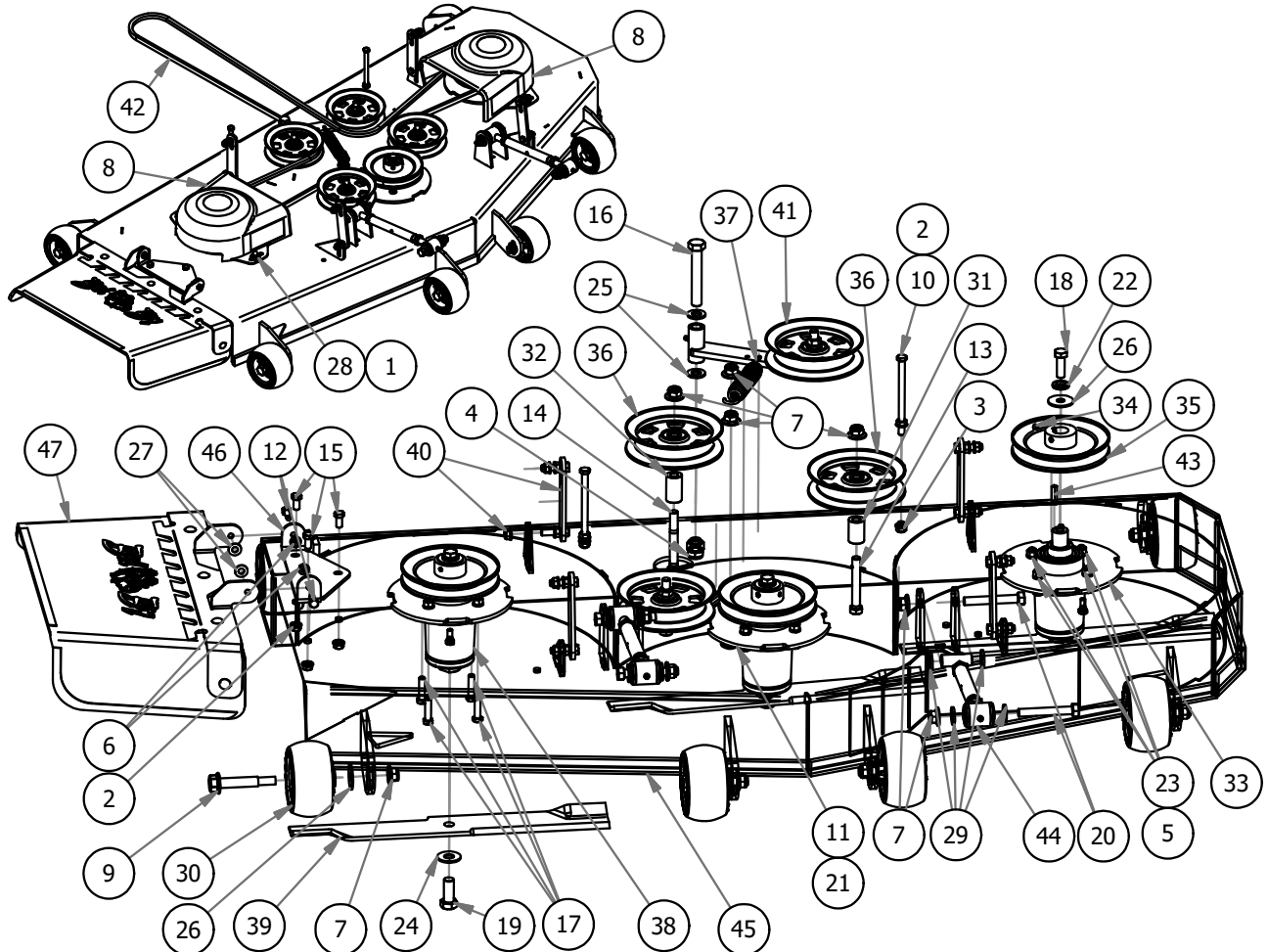



BAD BOY MOWERS

PARTS SECTION: DECK SUB-ASSEMBLIES

037-6015-50 Parts List				039-6945-17 Parts List			
ITEM	QTY	PART NUMBER	DESCRIPTION	ITEM	QTY	PART NUMBER	DESCRIPTION
1	1	037-6017-50	Aluminum Spindle Housing -2010	11	1	039-6945-00	Deck Idler
2	2	037-6023-00	Spindle Bearing, 2004 and up	12	1	025-5203-00	.51 ID X .75 OD X .75 LGTH SOLID SPACER ZINC
3	1	037-6026-00	Short Spindle Shaft w/Locking	13	1	013-8050-00	1/2-13 NYLON INSERT FLANGE LOCKNUT ZINC
4	1	037-8002-00	Dust Cover	14	1	018-6036-00	1/2-13 X 2-3/4 HEX CAP SCREW (GR.5) ZINC
5	1	037-8050-00	Tube Spacer for Spindle Shaft	15	1	033-8050-00	5" Idler Pulley
6	1	037-9050-00	Collar Spacer - Top of Spindle	039-6945-18 Parts List			
039-2127-17 Parts List				ITEM	QTY	PART NUMBER	DESCRIPTION
7	1	039-2127-00	2017 MZZT Deck Hanger	16	1	013-8050-00	1/2-13 Nylon Flange Nut
8	2	018-6012-00	3/8" x 1 1/2" Hex Bolt	17	1	018-6036-00	1/2" x 2 3/4" Hex Bolt
9	2	013-5201-00	3/8" Flange Nut	18	1	025-5203-00	Spacer 3/4 OD x 1/2 ID x 3/4 Length
10	2	013-5202-00	3/8" Nylock Flange Nut	19	1	033-8050-00	5" Idler Pulley
				20	1	039-6945-00	Deck Idler

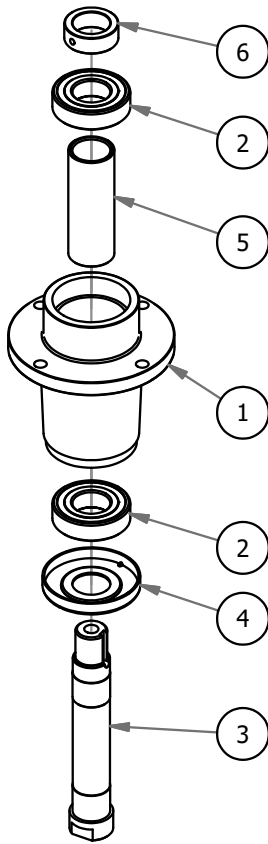

037-6015-50
Spindle- Aluminum -2012 ZT

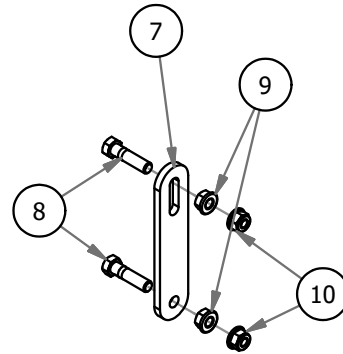

039-2127-17
Deck Hanger Assembly

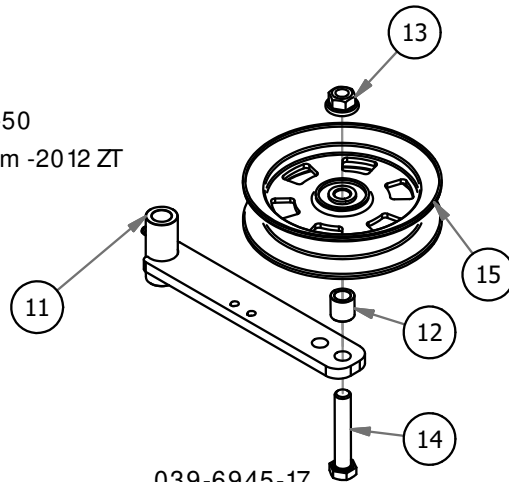

039-6945-17
2017 MZ/ ZT Deck Idler Assembly

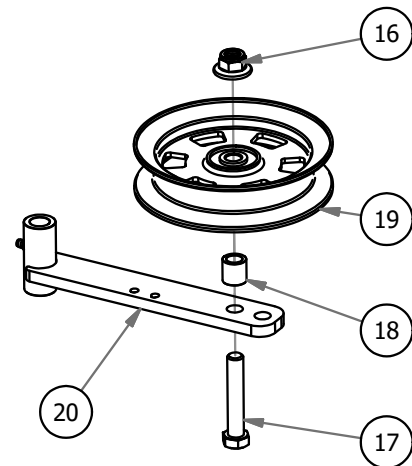

039-6945-18
2017 54"/ 48" Deck Idler Assembly



PARTS SECTION: DECK SUB-ASSEMBLIES (CONT.)

048-6000-00 Parts List				210-6005-48 Parts List			
ITEM	QTY	PART NUMBER	DESCRIPTION	ITEM	QTY	PART NUMBER	DESCRIPTION
21	1	013-0019-00	NUT, 5/8-18	29	1	039-4870-00	Discharge Upper Chute Bracket
22	1	013-0020-00	NUT, 5/8-18LH	30	1	039-4871-00	Discharge Lower Chute Bracket
23	2	024-0001-00	1/4-28 Grease Fitting	31	5	013-8049-00	5/16-18 NYLON INSERT FLANGE LOCKNUT ZINC
24	1	048-6001-00	2018 Maverick Toplink Body	32	1	210-6005-00	Rubber Discharge Chute
25	1	048-6002-00	2018 Maverick Bushing Retainer Left-Handed	33	5	018-4703-00	5/16-18 X 1-1/4 CARRIAGE BOLT ZINC
26	1	048-6003-00	2018 Maverick Bushing Retainer Right-Handed	210-6005-98 Parts List			
27	2	048-6004-00	2018 Maverick Bushing Sleeve	ITEM	QTY	PART NUMBER	DESCRIPTION
28	4	048-6005-00	2018 Maverick Bushing	34	1	210-6005-00	Rubber Discharge Chute
				35	1	039-4864-00	60° Discharge Chute Upper Hanger
				36	5	018-4703-00	5/16-18 X 1-1/4 CARRIAGE BOLT ZINC
				37	5	013-8049-00	5/16-18 NYLON INSERT FLANGE LOCKNUT ZINC
				38	1	039-4863-00	60° Discharge Lower Bracket

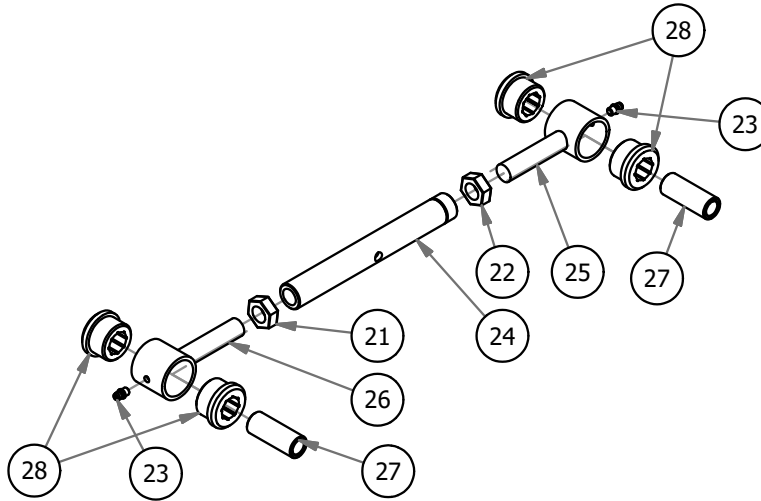

048-6000-00
2018 Maverick Turnbuckle (Top Link)

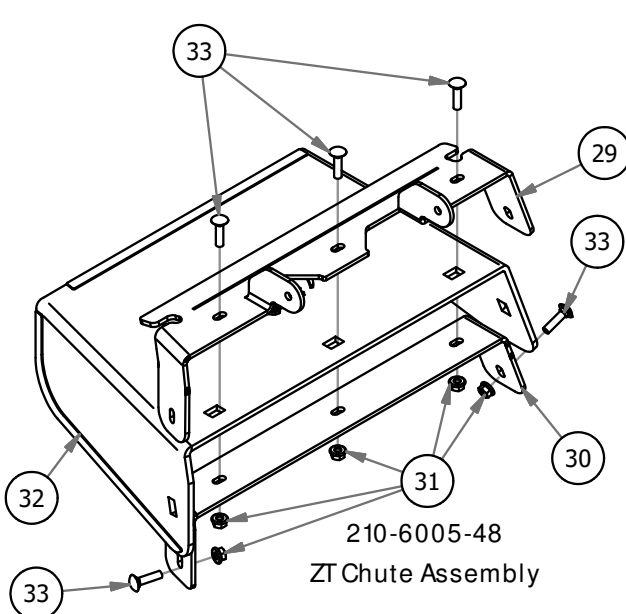

210-6005-48
ZT Chute Assembly

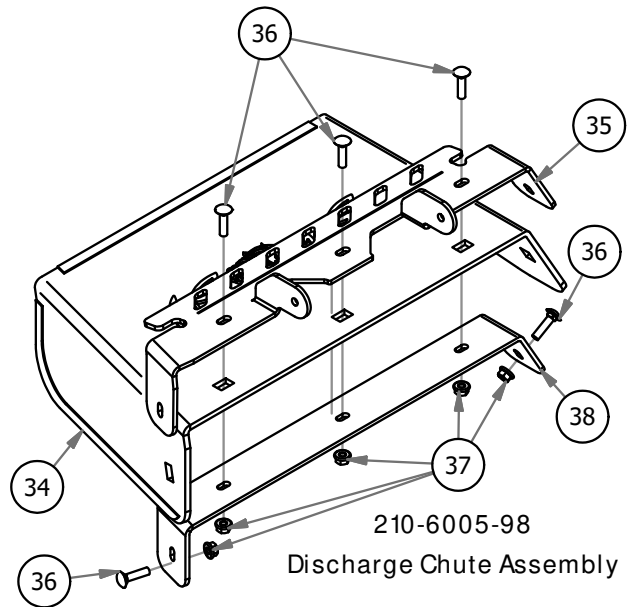

210-6005-98
Discharge Chute Assembly



BAD BOY MOWERS

PARTS SECTION: TRANSAXLE ASSEMBLY

Parts List				Parts List			
ITEM	QTY	PART NUMBER	DESCRIPTION	ITEM	QTY	PART NUMBER	DESCRIPTION
1	4	013-2050-00	1/4-20 Nylon Insert flange Nut	20	4	032-9000-00	Vibration Mount-Green Dot
2	10	013-3000-00	Acorn Lug Nut	21	4	032-9002-00	Vibration Mount-Red Dot (48" Maverick Only)
3	12	013-8049-00	5/16" Nylon Flange Nut	22	2	034-9080-00	Gold Transaxle Spring
4	4	013-8050-00	1/2-13 Nylon Flange Nut	23	4	039-0001-00	Maverick Rear Transaxle Pivot Bracket
5	8	018-1055-00	1/2" x 3/4" Hex Bolt	24	2	039-1306-00	Rear Susp Transaxle Mount
6	8	018-4701-00	5/16" x 3" Hex Bolt	25	1	039-1320-00	Brake Arm Ext (Left)
7	4	018-5344-00	5/16" x 2 1/2" Bolt	26	1	039-1321-00	Brake Arm Ext (Right)
8	4	018-8052-00	1/4" x 3/4" Hex Bolt	27	1	041-7400-00	75.8" Pump Belt
9	8	019-5702-00	1/2" Washer (Grade 8)	28	1	050-0075-00	3200 Left transaxle
10	4	019-8027-00	.515 ID Nylon Shoulder Washer	29	1	050-0080-00	3200 right transaxle
11	12	019-8044-00	5/16" Flat Washer	30	10	050-2012-00	Transaxle Wheel Stud
12	2	022-3010-00	Tire and Wheel Assembly (28 and 29) (48" Maverick Only)	31	2	050-2075-00	Fan/Pully Kit for ZT and Maverick
13	2	022-3011-00	12 x 7" Black Wheel (48" Maverick Only)	32	2	050-2077-00	Transaxle Hub
14	2	022-3025-00	23 x 8.50 - 12 Tire (48" Maverick Only)	33	2	063-1050-00	Filter
16	2	022-4200-00	2019 Maverick Reaper Turf Tire and Wheel Assembly	34	1	064-3050-00	Brake Cable, 18.5"
18	2	024-1200-00	45 degree fitting	35	1	064-3051-00	Brake Cable, 24.5"
19	4	032-5052-00	Bronze Bushing - SF - 2024-8	36	2	022-5465-00	23" x 10.50" X 12" Black Wheel Assembly

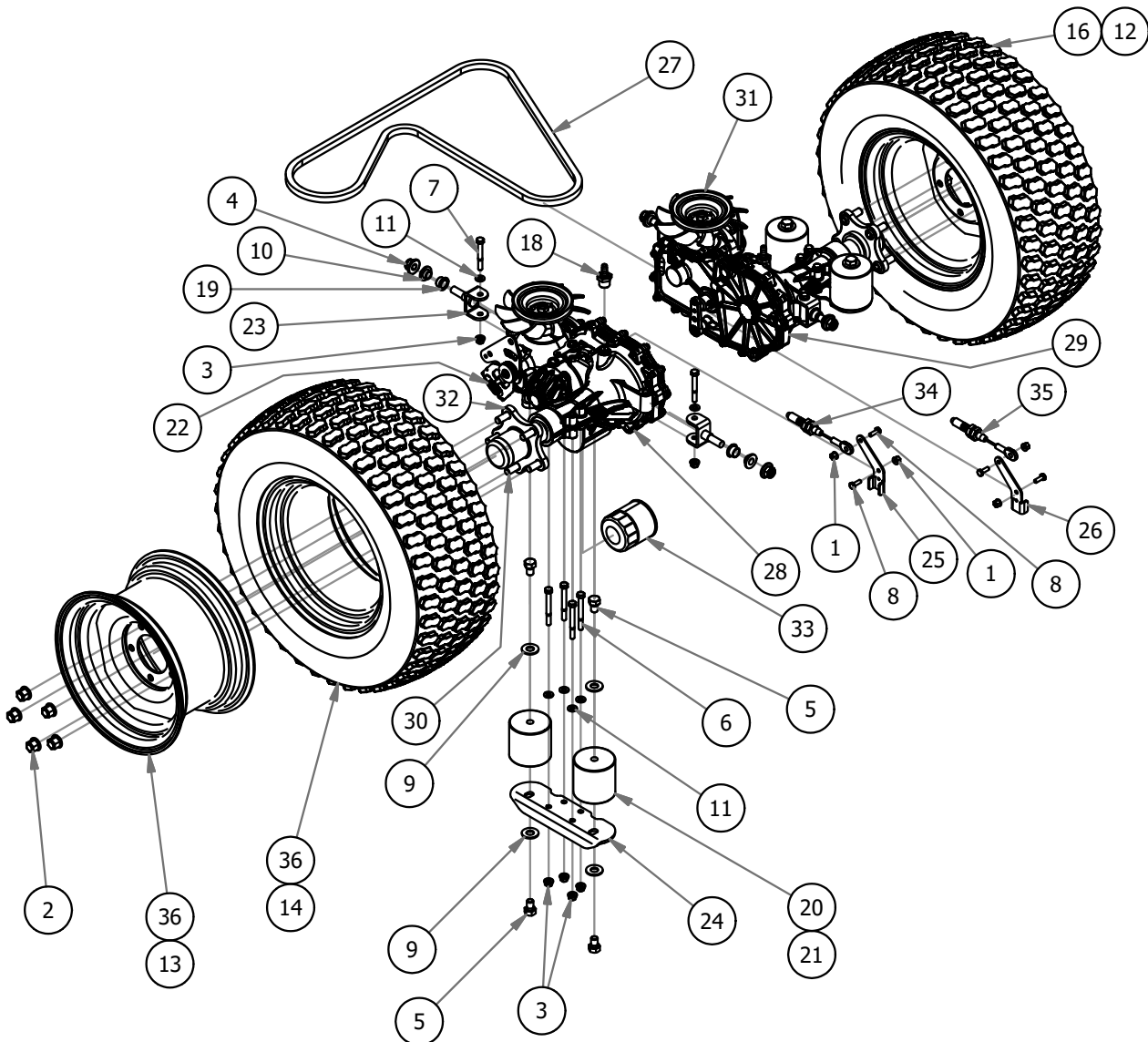



PARTS SECTION: ENGINE - FS-730 V KAWASAKI

Parts List				Parts List			
ITEM	QTY	PART NUMBER	DESCRIPTION	ITEM	QTY	PART NUMBER	DESCRIPTION
1	4	013-0075-00	M8-1.25 Zinc Nut	13	1	030-0050-00	5/16 Set Screw
2	2	013-8043-00	5/16" Nut	14	1	033-5035-00	4 3/4 Motor Pulley
3	1	015-0045-00	FS730V Engine	15	1	041-7400-00	75.8" Pump Belt
4	1	015-0052-00	Kawasaki Muffler 1251	16	1	042-5020-00	1/4 x 2 Square key Stock
5	2	015-2709-00	Exhaust Gasket	17	1	051-5404-00	Oil drain Hose
6	2	015-8001-00	Spark Plug - Kawasaki	18	1	063-2097-00	Kawasaki Air Filter
7	4	018-1075-00	3/8 x 1 1/8 bolt	19	1	063-6000-00	Universal Inline Fuel Filter
8	1	018-5321-00	M8x1.20x20MM Hex head bolt	20	1	063-8017-00	Kawasaki Oil Filter
9	1	018-5350-00	5/16-18 x 5-1/2 GR 5 Hex Bolt	21	1	064-0030-00	24" Black Ground Cable
10	1	018-5450-00	7/16"-20 x 2.5" Hex Bolt Gr. 8	22	1	070-0056-00	Clutch
11	1	019-6020-00	1/2" Belleville Washer	23	1	070-2000-00	Clutch Pigtail
12	6	019-8051-00	5/16" Lock Washer	24	1	070-5490-18	2018 Maverick Frame

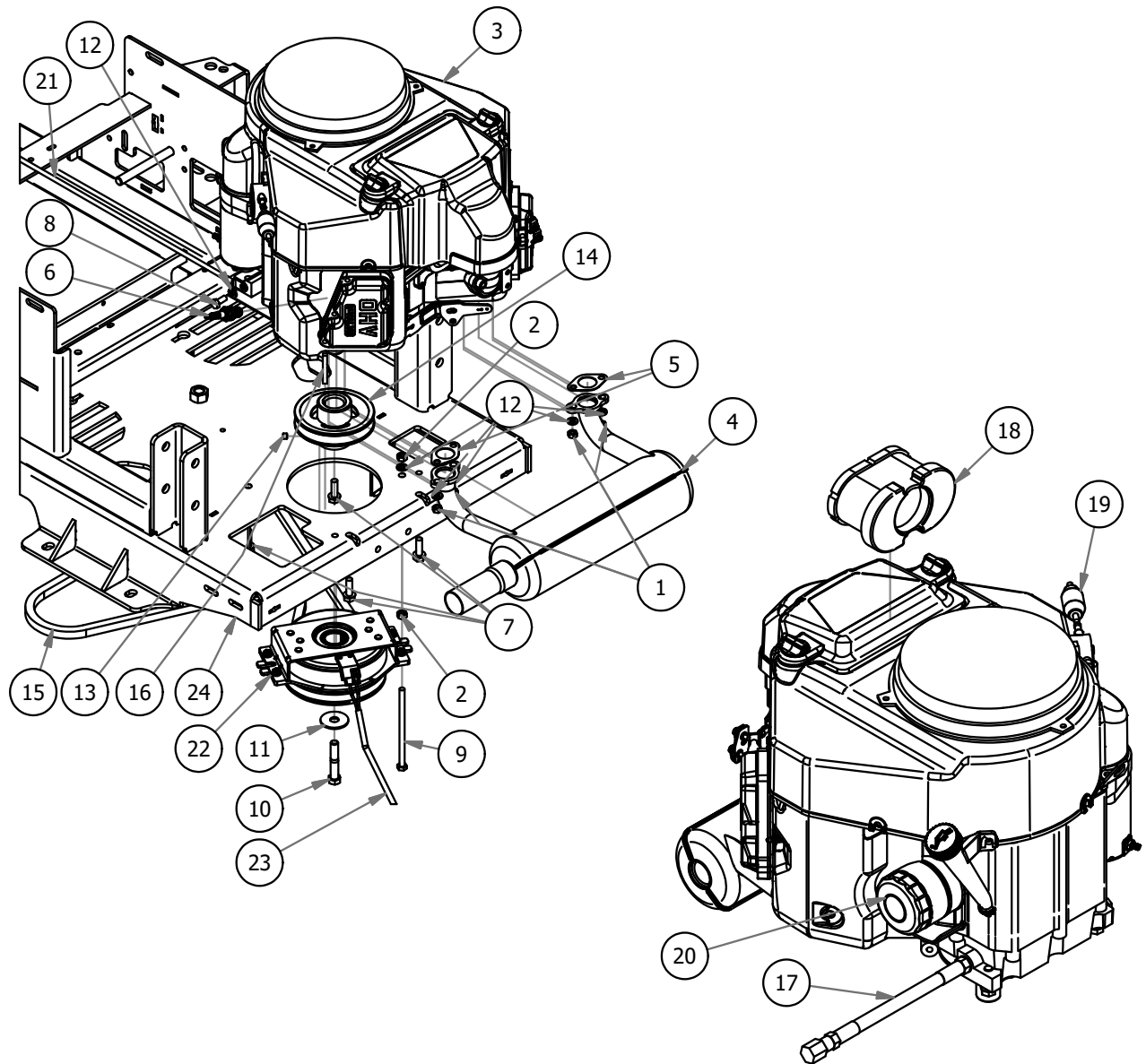



BAD BOY MOWERS

PARTS SECTION: ENGINE - 747cc KOHLER

Parts List				Parts List			
ITEM	QTY	PART NUMBER	DESCRIPTION	ITEM	QTY	PART NUMBER	DESCRIPTION
1	2	013-8043-00	5/16" Nut	13	1	030-0050-00	5/16 Set Screw
2	1	015-0051-00	Kohler Muffler	14	1	033-5035-00	4 3/4 Motor Pulley
3	1	015-2030-00	Kohler 747cc Engine	15	1	041-7400-00	75.8 Pump Belt
4	2	015-2751-00	Exhaust Gasket	16	1	042-5020-00	1/4 x 2 Square key Stock
5	1	051-5401-00	Oil drain Valve	17	1	063-5000-00	725 & 747 Kohler Oil Filter
6	2	015-8000-00	Spark Plug	18	1	063-5005-00	725 Kohler air filter
7	4	018-1075-00	3/8 x 1 1/8 bolt	19	1	063-6000-00	Universal Inline Fuel Filter
8	4	018-2007-00	5/16-18 x 1 GR 5 Hex Bolt Zinc	20	1	070-0056-00	Clutch
9	1	018-5350-00	5/16-18 x 5-1/2 GR 5 Hex Bolt	21	1	070-2000-00	Clutch Pigtail
10	1	018-5450-00	7/16"-20 x 2.5" Hex Bolt Gr. 8	22	1	070-5490-18	2018 Maverick Frame
11	1	019-6020-00	1/2" Belleville Washer	23	1	086-0005-00	Ground Cable
12	5	019-8051-00	5/16" Lock Washer	24	1	103-5400-00	Black Boot For Ground Cable

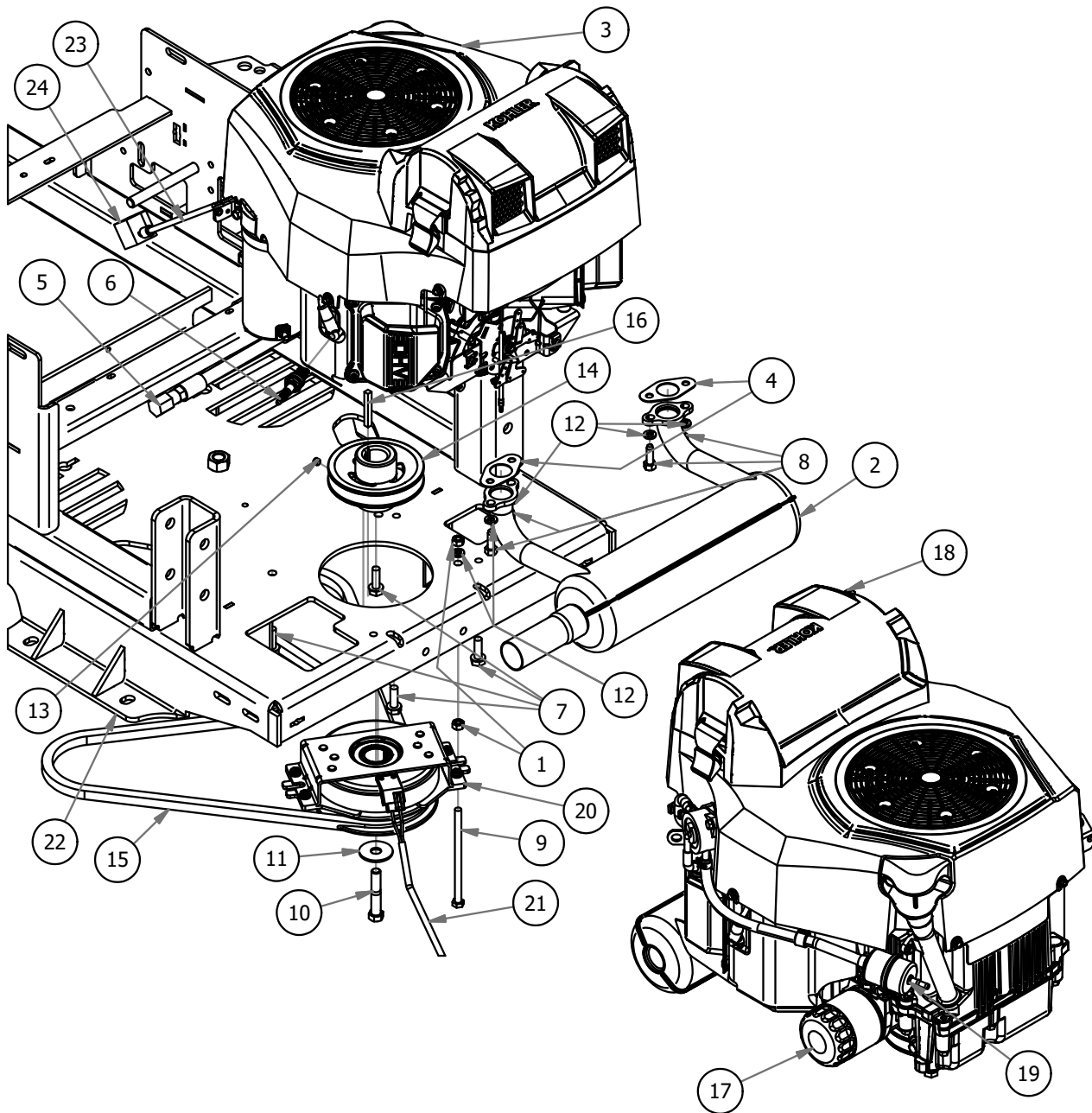



PARTS SECTION: ENGINE - GXV-630 HONDA

Parts List				Parts List			
ITEM	QTY	PART NUMBER	DESCRIPTION	ITEM	QTY	PART NUMBER	DESCRIPTION
1	2	013-0005-00	1/2" Center Lock Nut	19	1	018-5350-00	5/16-18 x 5-1/2 GR 5 Hex Bolt
2	4	013-0075-00	M8-1.25 Zinc Nut	20	4	018-6012-00	3/8 x 1.5" Bolt
3	4	013-6014-00	3/8" Hex Nut	21	2	018-6054-00	1/2-13 x 3 1/2 GR 5 Hex Bolt
4	2	013-8043-00	5/16" Nut	22	1	019-4008-00	1/4" Lock Washer
5	4	013-9001-00	1/4-20 Hex Flange Nuts Zinc w/Serrations	23	4	019-5037-00	3/8" Lock Washer
6	2	015-0077-01	Exhaust Gasket	24	1	019-6020-00	1/2" Belleville Washer
7	1	015-0091-00	2019 Honda Engine	25	5	019-8051-00	5/16" Lock Washer
8	1	015-0091-01	Oil Filter	26	1	030-0050-00	5/16 Set Screw
9	1	015-0091-02	Pre-Cleaner	27	1	033-5035-00	4 3/4 Motor Pulley
10	1	015-0091-03	Air Cleaner Element	28	1	041-7400-00	75.8" Pump Belt
11	2	015-0091-04	Spark Plug	29	1	042-5020-00	1/4 x 2 Square key Stock
12	1	015-0091-05	Fuel Filter	30	1	051-5405-00	Honda Oil Drain
13	1	015-0091-06	Regulator Rectifier for Honda Engine	31	1	064-0030-00	Ground Cable
14	1	015-1016-00	2019 Honda Maverick Muffler	32	1	070-0056-00	Clutch
15	1	018-0024-00	M6-1.0 X 16MM Hex Bolt	33	1	070-5490-18	2018 Maverick Frame
16	2	018-2012-00	1/4" x 1/2" BS C/S 18-8 SS	34	2	086-1201-00	Relay Terminal
17	2	018-4007-00	1/4-20 x 1 GR 5 hex bolt zinc	35	1	086-9012-00	Wiring Harness
18	1	018-5300-00	7/16" x 2 1/2" Hex Bolt	36	1	201-0020-00	Honda Rectifier Mount

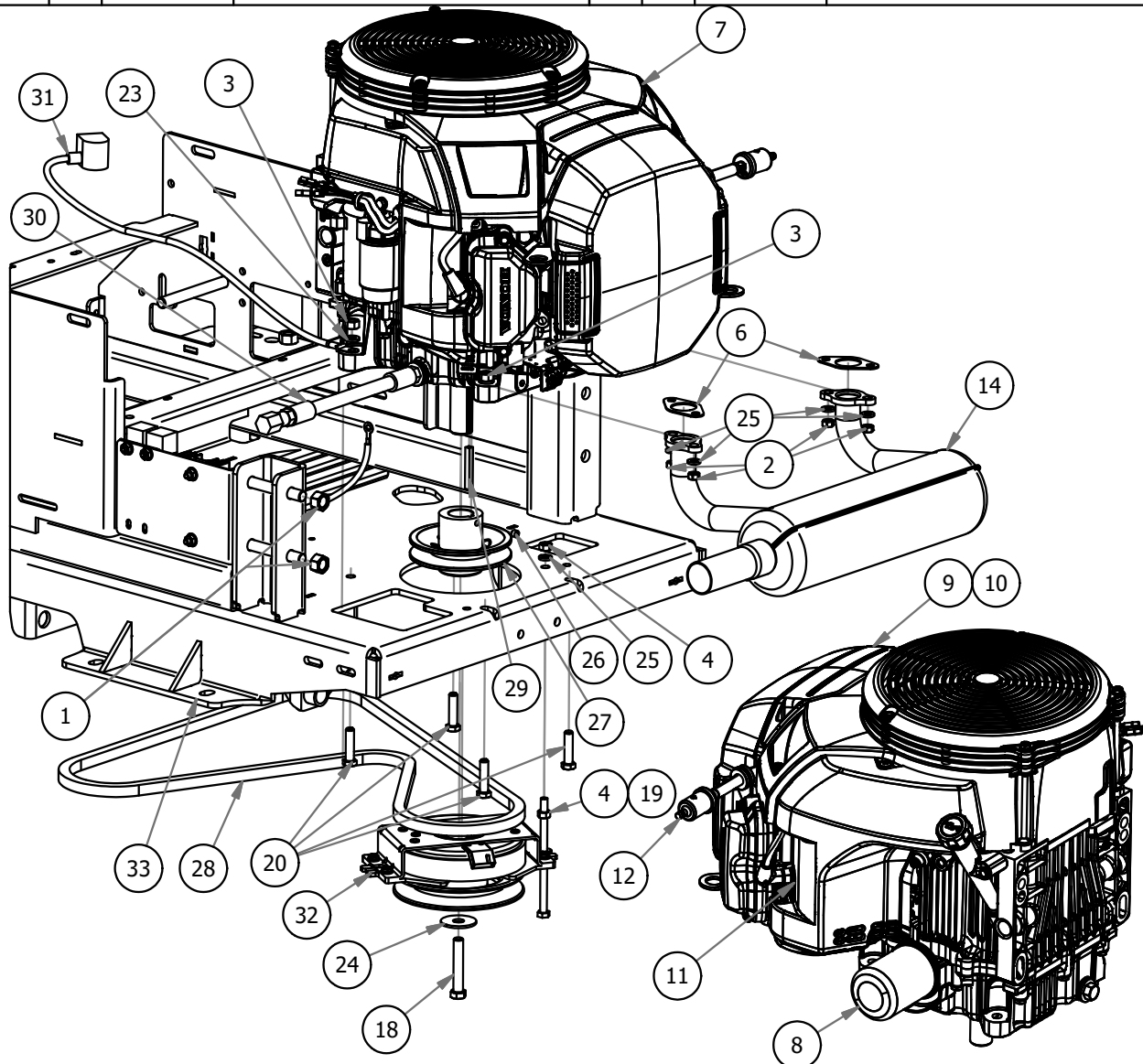



BAD BOY MOWERS

PARTS SECTION: ENGINE - GXV-630 HONDA

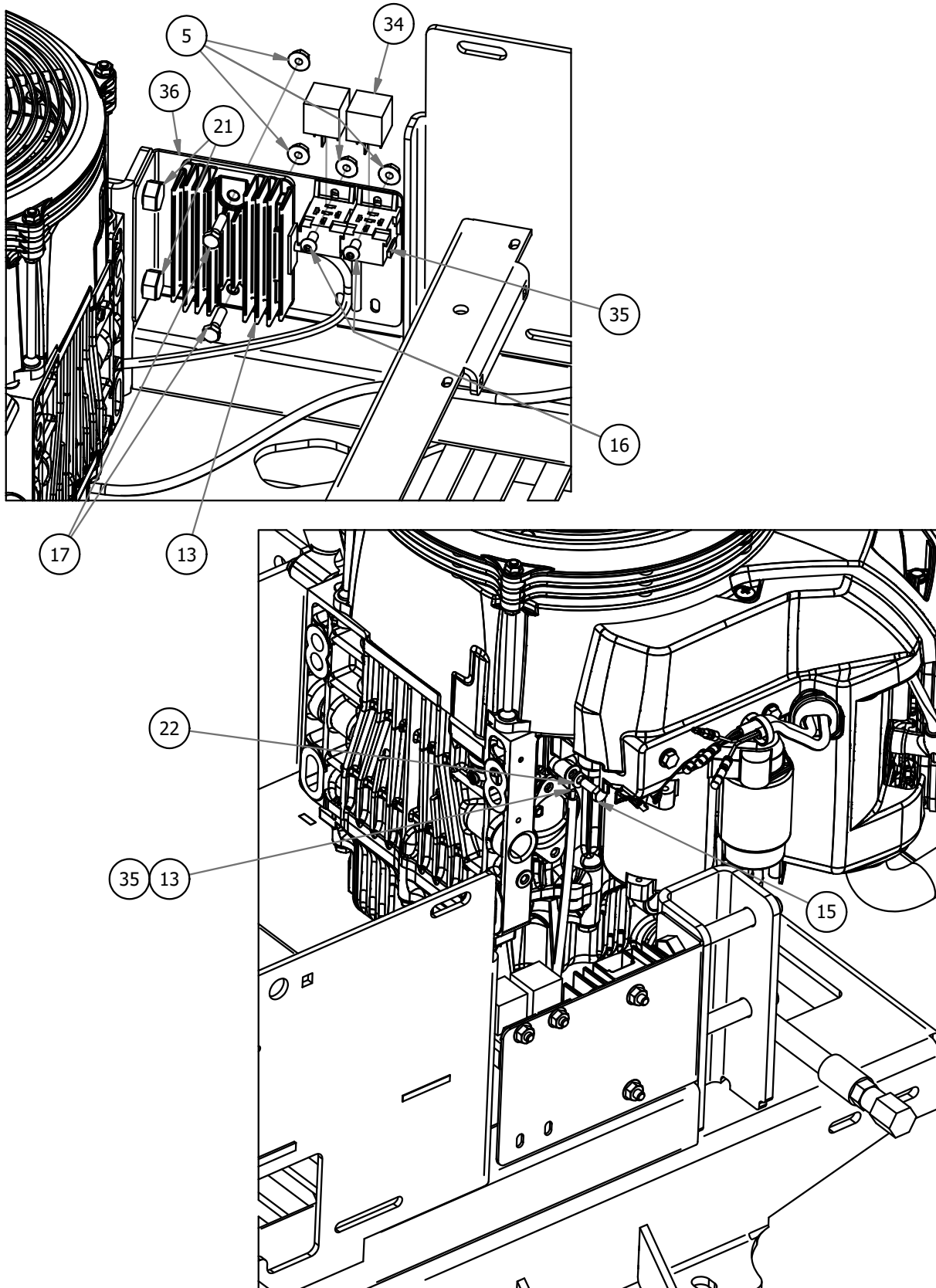



BAD BOY MOWERS

PARTS SECTION: DECALS



091-0313-00
Frong Logo Decal



091-0022-00
Maverick Kick Plate Decal



091-0490-18
688cc Decal



091-0378-18
726cc Decal



091-0379-18
747cc Decal



091-0339-18
Brake Decal



091-0019-00
Patent Decal

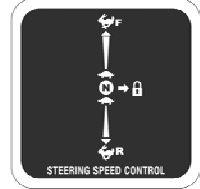
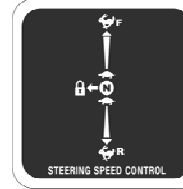

091-0021-00
Steering Speed
Control Decal



091-0903-18
48" Deck Decal



091-0904-18
54" Deck Decal



091-0905-18
60" Deck Decal

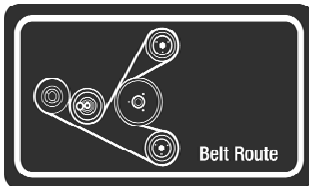

091-3017-50
Pump Belt Route Decal

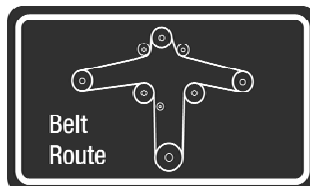

091-3309-00
Deck Belt Route Decal



091-1020-00
Caution Decal



091-3012-00
Danger Decal

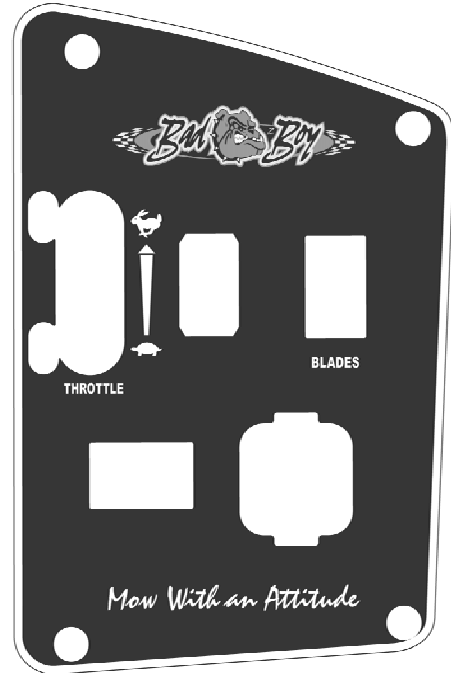

091-0338-18
Instrument Panel Decal



091-3150-00
Caution/Danger Decal



2020 LIMITED WARRANTY FOR BAD BOY MAVERICK MOWERS

1. WHAT THIS WARRANTY COVERS, AND FOR HOW LONG:

Bad Boy, Inc. will, at its option, repair or replace, without charge, any part covered by the warranty which is found to be defective in material and/or workmanship for two (2) years or (400) hours* after the date of sale to the original retail purchaser **unless the product is used for rental purposes, in which case there is no warranty.**

The leading edge of the deck shell will be warranted for the entire life time of the machine to the original purchaser against defects in materials and workmanship. Labor required to repair or replace the leading edge of the deck shell will be covered by Bad Boy, Inc for the first year and at the unite owner's expense during the balance of the lifetime of the machine.

Belts are warranted for a period of ninety (90) days against materials or workmanship defects.

Seats are warranted for a period of (6) months against material or workmanship defects.

At Bad Boy, Inc.'s request, customer will make the defective part available for inspection by Bad Boy, Inc. and/or return the defective part to Bad Boy, Inc., **transportation charges prepaid.**

2. WHAT THIS WARRANTY DOES NOT COVER:

- A. This warranty does not cover defects caused by depreciation or damage caused by normal wear, accidents, improper maintenance, improper use or abuse of the product, alterations, or failure to follow the instruction contained in the Owner's Manual for operation and maintenance.
- B. The customer shall pay any charges for making service calls and/or for transporting the mower to and from the place where the inspection and/or warranty work is performed.
Bad Boy Inc will not be responsible for the pickup and delivery of a machine for warranty purposes.
- C. Engines are warranted separately by their respective manufacturer. The available warranties covering this item are furnished with each mower. Bad Boy, Inc does not assume any warranty obligation, liability or modification for this item, which is covered exclusively by the stated warranty of the respective manufacturers.
- D. Tires, blades, deck anti-scalping wheels, and dust covers are considered to be consumable wear items and are therefore not warranted.
- E. Batteries are warranted for six months (free replacement) from the retail purchase date against materials or workmanship defects. The battery warranty must be obtained through the battery manufacturer.
- F. Normal maintenance services such as oil change, cleaning, lubrication, adjustment.
- G. Replacement of services, items, such as oil, lubricants, spark plugs, belts, rubber hoses or other items subject to normal service replacement.

3. HOW TO OBTAIN SERVICE UNDER THIS WARRANTY:

- A. Warranty service can be arranged by contacting the dealer where you purchased the mower. Proof of the date of purchase may be required to verify warranty coverage. Warranty repairs must be completed by an authorized Bad Boy center.
- B. **Warranty claims will not be reviewed or paid unless the warranty registration is received by Bad Boy, Inc. within 30 days of the retail purchase date.**
- C. Warranty claims requiring parts returned will be settled upon return of parts to Bad Boy for inspection.
- D. All warranty issues must be handled through an authorized service center or dealership.

4. WARRANTY LIMITATION:

- A. **THERE IS NO OTHER EXPRESS WARRANTY. ANY WARRANTY THAT MAY BE IMPLIED FROM THIS PURCHASE INCLUDING MERCHANTABILITY AND FITNESS FOR A PARTICULAR PURPOSE IS HEREBY LIMITED TO THE DURATION OF THIS WARRANTY AND TO THE EXTENT PERMITTED BY LAW ANY AND ALL IMPLIED WARRANTIES ARE EXCLUDED.** Some states do not allow limitations on how long an implied warranty lasts, so the above limitations may not apply to you.

- B. **BAD BOY, INC. WILL NOT BE LIABLE FOR ANY INCIDENTAL, CONSEQUENTIAL, OR SPECIAL DAMAGES AND/OR EXPENSES IN CONNECTION WITH THE PURCHASE OR USE OF THE MOWER.** Some states do not allow the exclusion or limitation of incidental or consequential damages, so the above limitation(s) or exclusion(s) may not apply to you.

- C. Only the warranty expressed in this limited warranty shall apply and no dealer, distributor, or individual is authorized to amend, modify, or extend this warranty in any way. Accordingly, additional statements such as dealer advertising or presentations, whether oral or written, do not constitute warranties by Bad boy, Inc., and should not be relied on.
- D. This warranty extends only to turf equipment operated under normal conditions and properly serviced and maintained. The warranty expressly does not cover (i) any defects, damage or deterioration due to normal use, wear and tear, or exposure; (ii) normal maintenance services such as oil change, cleaning, lubrication, adjustment; (iii) replacement of services, items, such as oil, lubricants, spark plugs, belts, rubber hoses or other items subject to normal service replacement; (iv) damage or defects arising out of or relating to misuse, neglect, alteration, negligence or accident; (v) repair or replacement arising from operation of or use of the turf equipment which is not in accordance with operating instructions as specified in the operator's manual or other operational instructions provided by Bad Boy Inc.; (vi) repair or replacement arising as a result of any operation from turf equipment that has been altered or modified so as to, indetermination of Bad Boy, Inc., adversely affect the operation, performance or durability of the equipment or that has altered, modified or affected the turf equipment so as to change the intended use of the product; (vii) repair or replacement necessitated by use of parts, accessories or supplies, including gasoline, oil or lubricants, incompatible with the turf equipment or other than as recommended in the operator's manual or other operational instructions provided by Bad Boy, Inc.; (viii) repairs or replacements resulting from parts or accessories which have adversely affected the operation, performance or durability of the turf equipment; or (ix) damage or defects due to or arising out of repair of turf equipment by person or persons other than an authorized Bad Boy, Inc., service dealer or the installation of parts other than genuine Bad Boy, Inc., recommended parts.
As a condition to this warranty, customer shall have read the operator's manual and ensured the mower has been registered within 30 days of purchase.
- E. This warranty gives you specific legal rights, and you may also have other rights, which vary from state to state.



BAD BOY, INC.
102 INDUSTRIAL DRIVE
BATESVILLE, AR 72501
WWW.BADBOYMOWERS.COM

Technical Support: techsupport@badboymowers.com
Warranty: warranty@badboymowers.com
Parts: partsdept@badboymowers.com

WARRANTY REGISTRATION

**Ensure selling dealership has registered mower within
30 days of purchase to validate warranty.**

Please record your serial number, date of purchase and dealership information
for your records.

Serial # _____

Date of Purchase _____

Dealer Information _____



**BAD BOY
MOWERS**

www.badboymowers.com

Bad Boy, Inc.

102 Industrial Drive

Batesville, Arkansas 72501