

DIESEL MODELS

ZERO-TURN MOWER OWNER'S, SERVICE & PARTS MANUAL

For additional information, please see us at
www.badboymowers.com

Bad Boy, Inc.
102 Industrial Drive
Batesville, Arkansas 72501
(870) 698-0090

TABLE OF CONTENTS

Basic Information..... Section 1 (page 4)

Bad Boy Safety Guidelines Section 2 (pages 5–8)

Operation Section 3 (pages 9)

Maintenance Section 4 (page 10)

Storage and Transportation Section 5 (page 10)

Troubleshooting and FAQ.....Section 6 (page 11)

Controls Section 7 (page 12)

Moving In-operable Mower Section 8 (page 13)

Instrumentation Section 9 (page 13)

Mower Blade MaintenanceSection 10 (page 14)

Greasing Bearings.....Section 11 (pages 14)

How to choose the right bladePage 15

Mowing TipsPage 16

SERVICE SECTION BEGINS ON PAGE 17
PARTS SECTION BEGINS ON PAGE 25
LIMITED WARRANTY PAGE 54



This manual applies to the following equipment:

Bad Boy Diesel Series

Diesel 7200 72" 35hp 4-Cylinder Diesel

Diesel 6100 61" 35hp 4-Cylinder Diesel

Diesel Compact 6100 61" 28hp 3-Cylinder Diesel

COMMONLY USED ITEMS AND PART NUMBERS

72" Blade	Hi-Lift Fusion 038-7230-00	Gator Blade 038-5400-00	Wave Blade 038-7215-00
61" Blade	Hi-Lift Fusion 038-6080-00	Gator Blade 038-6081-00	Wave Blade 038-6091-00
Deck Belt	72" 041-2525-00	61" 041-0236-000	61" Compact 041-0226-00
Pump Belt	72" 041-8411-00	61" 041-5048-00	
CATERPILLAR Oil Filter	CAT 28hp 063-2010-00		
Air Filter	CAT 28hp Inner 063-2060-00	CAT 28hp Outer 063-2050-00	
CATERPILLAR Oil Filter	CAT 35hp 063-2010-00		
Air Filter	CAT 35hp Inner 063-2060-00	CAT 28hp Outer 063-2050-00	
Motor Oil	15w40 (Reference Owner's Manual)		
Hydro Oil	20w50 (8 quarts)		

SECTION 1: BASIC INFORMATION

Congratulations on the purchase of your new Bad Boy Mower! The purpose of this manual is to assist operators in maintaining and operating their machine. The information and instructions in this manual can help you attain years of performance from your new Bad Boy. Also, check out our website to learn more about the Bad Boy family.

- 1.1 Diesel engines use 15W40 engine oil. Conventional or Synthetic may be used.
Refer to the engine's service manual.
- 1.2 All Bad Boy hydraulic systems use 20W50 engine oil. Conventional or Synthetic may be used.
- 1.3 All Bad Boy Mowers use hi-temp multi-purpose grease. NLGI No. 2 for the grease fittings.
- 1.4 Diesel models have 12 psi in both front and rear tires.

Warranty Registration

The Warranty Registration form must be completed and signed to validate your warranty. As the new equipment owner, you are expected to see that the form is completed and forwarded to Bad Boy, Inc., at time of delivery. Warranty is non transferable.

Model/Serial Number

Your Diesel model serial numbers are found on the SIN plate underneath seat. The serial numbers are necessary on the warranty registration form. Also, these numbers can assist you in the ordering of new parts when replacements become necessary.

Parts/Service

Only Bad Boy replacement parts are to be used on your mower.

Replacement parts are available through your local Bad Boy Mower Dealer. Remember to always provide the following information when ordering parts:

1. Correct part number
2. Correct serial number

All warranty repair and service must be handled through your authorized Bad Boy Mowers dealer.

To locate the nearest dealer, go to our website and click on Locate a Dealer.

EVAPORATIVE EMISSION CONTROL WARRANTY STATEMENT

Federal Evaporative Emission Control Warranty: Your Warranty Rights and Obligations

The Environmental Protection Agency (EPA), and Bad Boy Inc. are pleased to explain the evaporative emission control system's warranty on your 2014 equipment. New equipment that uses spark ignition engines for off-road use must be meet stringent anti-smog standards. The evaporative emission control system on your equipment is designed, built, and equipped so it conforms at the time of sale to the ultimate purchaser with the requirements of 40 CFR 1060. The evaporative emission control system is free from defects in materials and workmanship that may keep it from meeting said requirements. Bad Boy Inc. must warrant the evaporative emission control system on your equipment for two years provided there has been no abuse, neglect or improper maintenance. If an evaporative emission control system component does fail in a manner that would cause the equipment to no longer meet the requirements of 40 CFR 1060 within the first two years Bad Boy Inc. will replace the defective component. Your evaporative emission control system may include parts such as fuel tanks, fuel lines, carbon canisters, fuel caps, valves, vapor hoses, clamps, or connectors.



SECTION 2: MOWER SAFETY GUIDELINES

Never allow untrained people to operate this machine. It is the owner's responsibility to get training and see to it that anyone who has permission to use your machine receives the proper training. Do not mow around people. The factory discharge chute is designed to deflect debris downward, but it could be possible for debris to be thrown in a way that can cause damage to people or property. Seek additional training when possible to learn more about safety techniques and practices. **This cutting machine is capable of amputating hands and feet and throwing objects. Failure to observe the following safety instructions could result in serious injury or death.**

GENERAL OPERATION

- 2.1 Read, understand, and follow all instructions on the machine and in the manual before starting.
- 2.2 Do not put hands or feet near rotating parts or under the machine. Keep clear of the discharge opening at all times.
- 2.3 Always remain seated while operating the machine. If the machine is equipped with Roll Over Protection (ROPs), always buckle your seat belt.
- 2.4 Only allow responsible adults who are familiar with the instructions to operate this machine.
- 2.5 Clear the area of objects such as rocks, wire, toys, etc., which could be thrown by the blades.
- 2.6 Always maintain a safe distance from people and pets just prior to, and during, operation. Stop the machine if anyone enters the area.
- 2.7 Never carry passengers.
- 2.8 Do not mow in reverse unless absolutely necessary. Always look down and behind before and while backing.
- 2.9 Never direct discharged material toward anyone. Avoid discharging material against a wall or obstruction as material may ricochet back toward the operator. Stop the blades when crossing gravel surfaces.
- 2.10 Never operate the machine without the discharge chute, grass catcher, or other safety devices correctly in place and functioning properly.
- 2.11 Slow down before turning.
- 2.12 Always disengage blades, place steering controls in neutral, engage parking brake, and remove ignition key when leaving operators seat. Never leave a running machine unattended.
- 2.13 Disengage blades when not mowing. Shut off engine and wait for all parts to come to a complete stop before cleaning the machine, inspecting the machine for damage, removing the grass catcher, or unclogging the discharge guard.
- 2.14 Always operate machine in daylight or with adequate working lights.
- 2.15 Do not operate the machine while under the influence of alcohol or drugs.
- 2.16 Watch for traffic when operating near or crossing roadways.
- 2.17 Always wear eye protection when operating or servicing the machine.
- 2.18 Always wear ear protection, such as earplugs, while mowing.
- 2.19 Use extra care when loading or unloading the machine into a trailer or truck.
- 2.20 Be alert of surroundings. Watch for rocks, stumps, mounds, depressions, and low hanging limbs or objects that could be potentially hazardous while mowing.
- 2.21 Data indicates that operators 60 years of age and above are involved in a large percentage of riding mower related injuries. These operators should periodically evaluate their ability to operate the riding mower safely enough to protect themselves and others from serious injury.

SLOPE OPERATION

Slopes are a major factor related to loss of control and tip over accidents, which can result in severe injury or death. Operation on all slopes requires extra caution. If you cannot back up the slope, or you feel uneasy on it, do not mow it.

- 2.22 Mow up and down slopes, not across.
- 2.23 Watch for holes, ruts, bumps, rocks, or other hidden objects that tall grass can obscure. Uneven terrain could overturn the machine.
- 2.24 Choose a low ground speed when operating the machine on a slope.
- 2.25 Do not mow on wet grass, the tires may lose traction.
- 2.26 Do not attempt to coast down a slope in the neutral position.
- 2.27 Avoid starting, stopping, or turning on a slope. If the tires lose traction, disengage the blades and proceed slowly, straight down the slope.
- 2.28 Keep all movement on slopes slow and gradual. Sudden changes in speed or direction could cause the machine to roll over.
- 2.29 Use extra care while operating machine with grass catchers or other attachments: they can affect the stability of the machine. Do not use on steep slopes.
- 2.30 Do not try to stabilize the machine by putting your foot on the ground.
- 2.31 Do not mow near drop offs, ditches or embankments. The machine could suddenly roll over if a wheel goes over the edge or the edge caves in.
- 2.32 Be aware of what is located at the bottom of slopes. For example: rocks water, cliffs, and roadways.

CHILDREN

Tragic accidents can occur if the operator is not alert to the presence of children. Children are often attracted to the machine and the mowing activity. NEVER assume that children will remain where you last saw them.

- 2.33 Keep children out of the mowing area and in the watchful care of a responsible adult other than the operator.**
- 2.34 Maintain alertness and turn machine off if a child enters the area.**
- 2.35 Before and while backing, look behind and down for small children.**
- 2.36 Never carry children, even with the blades shut off. They may fall off and be seriously injured or interfere with safe machine operation. Children who have been given rides in the past may suddenly appear in the mowing area for another ride and be run over or backed over by the machine.**
- 2.37 Never allow children to operate the machine.**
- 2.38 Never leave key in the ignition, especially around children.**
- 2.39 Use extreme care when approaching blind corners, shrubs, trees, or other objects that may block your view of a child.**

TOWING

- 2.40 Tow only with a machine that has a hitch specifically designed for towing. Do not attach towed equipment except at the hitch point.
- 2.41 Follow the manufacturer's recommendation for weight limits for towed equipment and towing on slopes.
- 2.42 Never allow children or others in or on towed equipment.
- 2.43 On slopes, the weight of the towed equipment may cause loss of traction and loss of control.
- 2.44 Travel slowly and allow extra distance to stop.



SERVICE:

SAFE HANDLING OF GASOLINE

To avoid personal injury or property damage, use extreme care in handling gasoline. Gasoline is extremely flammable and the vapors are explosive.

- 2.45 Extinguish all cigarettes, cigars, pipes, and all other sources of ignition.
- 2.46 Use only an approved gasoline container.
- 2.47 Never remove gas cap or add fuel with the engine running.
- 2.48 Allow engine to cool before refueling.
- 2.49 Never fuel the machine indoors.
- 2.50 Do not store machine near open flame or source of ignition, such as a water heater or furnace.
- 2.51 Remove gas powered equipment from the truck or trailer and refuel it on the ground. If this is not possible, then refuel such equipment with a portable container, rather than from a gasoline dispenser nozzle.
- 2.52 Never fill gasoline containers inside a vehicle or on a truck or trailer bed with a plastic liner. Always place containers on the ground away from your vehicle before filling.
- 2.53 Keep the nozzle in contact with the rim of the fuel tank or container opening at all times until the fueling is complete. Do not use a nozzle lock-open device.
- 2.54 If fuel is spilled on clothing, change clothing immediately.
- 2.55 Never overfill fuel tank. Replace gas cap and tighten securely.

GENERAL SERVICE

- 2.56 Never operate machine in a closed area where dangerous carbon monoxide fumes can collect.
- 2.57 Keep all nuts and bolts tight to be sure the equipment is in safe working condition. Never operate a poorly maintained machine.
- 2.58 Do not touch hot areas of the machine.
- 2.59 Never interfere with the intended function of a safety device or reduce the protection provided by a safety device. Check their proper operation regularly.
- 2.60 Keep the entire machine free of grass, leaves, or other debris build up. Clean up oil or fuel spillage and remove any fuel soaked debris. Failure to do so can affect the safety and functionality of the machine, as well as increase the danger of a fire due to contact with the hot surfaces of the machine.
- 2.61 Allow machine to cool before storing.
- 2.62 If you strike something with the mower, turn the mower and blades off, engage the parking brake, and inspect the machine for damage. Repair, if necessary, before resuming.
- 2.63 Never make any adjustments or repairs with the engine running.
- 2.64 Check grass catcher components and the discharge guard frequently and replace with manufacturer's recommended parts, when necessary.
- 2.65 Mower blades are sharp. Wrap the blade or wear gloves before servicing them.
- 2.66 Check parking brake operation frequently. Adjust and service as required.
- 2.67 Maintain or replace safety and instruction labels, as necessary.
- 2.68 Do not attempt to mount a tire without the proper equipment and experience to perform the job.

-
- 2.69 Always maintain the correct tire pressure. Do not inflate the tires above the recommended pressure. Never weld or heat a wheel and tire assembly. The heat can cause an increase in air pressure resulting in a tire explosion. Welding can structurally weaken or deform the wheel.
- 2.70 Park machine on level ground. Never allow untrained personnel to service machine. Understand service procedure before doing work.

SAFETY INTERLOCK SYSTEM

Your Bad Boy mower is equipped with a safety interlock system. This system is designed to prevent serious injury or death to the operator and other people or property damage. The system consists of an operator presence switch in the seat, the parking brake, drive lever neutral position, the mower blade engagement switch, and the ignition switch.

These interlocks are vitally important and must be tested frequently. Following are instructions to test these very important safety precautions. **Note: the operator must be seated properly on the machine during these tests and the engine should have been previously allowed to warm to operating temperature.**

- 2.71 With the parking brake engaged, bring lever arms to their inward position, then attempt to start the machine (the blade actuator should be in off position); the engine should not start.
- 2.72 On a level surface, disengage the parking brake and place lever arms to their outward position, then attempt to start the machine (the blade actuator should be in off position); the engine should not start.
- 2.73 Engage parking brake and leave lever arms in outward position, put blade actuator in the on position, then attempt to start the machine; the engine should not start.
- 2.74 Next, start the engine as stated in the "Mower Operation Section", disengage parking brake, and Very Slowly begin to rise from the seat; the engine should stop.

If any of these tests fail to produce the results indicated and the problem cannot be identified, contact your Bad Boy Mower dealer or the support contacts in the rear of this manual.

ROLL OVER PROTECTION STRUCTURES (ROPS)

If your machine is equipped with ROPS, it is of utmost importance they are used properly. ROPS, when used correctly, dramatically decrease the fatality rate in instances when the machine overturns.

- 2.75 Periodically ensure the bolts that attach the ROPS to the machine are securely fastened.
- 2.76 Always operated the machine with the ROPS secured in the upright position.
- 2.77 If the surrounding environment (e.g. low lying limbs, signage, etc.) makes it impossible to mow with the ROPS upright, lower the ROPS at the hinge point, mow the area, then immediately secure the ROPS upright.
- 2.78 Upright ROPS are taller than then operators head. Be aware of this and your surrounding environment, as referenced above. The mower and operator may clear low lying items, but the ROPS may not.
- 2.79 Always wear the provided seat belt when ROPS are utilized. Failure to use the seat belt severely handicaps the safety benefits of the ROPS.
- 2.80 In the event of a roll-over, replace the ROPS before resuming use of the machine.



SECTION 3: MOWER OPERATION

Never operate the machine with faulty equipment. Always be alert of sudden changes in landscape, as the mower will react differently on slopes or embankments than it will on flat surfaces. Never operate the mower with the discharge chute open. Do not cross terrain, other than grass, with blades turning. This could cause damage to property or bystanders.

- 3.1 Place parking brake in up position
- 3.2 Drive arms must be in the “open” position. While sitting on the machine, each arm is positioned away from the operator, to the right and left. Drive arms will lock into place and must be in this position to start machine.
- 3.3 Put PTO switch in the OFF position.
- 3.4 If your machine has been equipped with a ROPS (Roll Over Protection System) then you must fasten seatbelt.
- 3.5 If machine has not been started recently, engage the choke.
- 3.6 Make sure nothing is under or around machine.
- 3.7 Place key in ignition and turn.
- 3.8 Once machine is started, disengage the choke.
- 3.9 Increase RPM by sliding the throttle to fast position, toward the rabbit.
- 3.10 Owners must become familiar with the controls before operating a zero-turn radius vehicle.
- 3.11 Start slowly and build your skill level. Have ample practice before using the machine at full capabilities.
- 3.12 Be comfortable with machine before engaging blades. Know what each component controls before using machine.
- 3.13 Your mower will perform differently on an incline /decline. Be cautious, slow down, and do not make any sudden jerking movements with control arms. The machine could lose traction on a decline or tip backwards on an incline.
- 3.14 Once you become comfortable with your Bad Boy Mower you will notice your overall mowing time will decrease.

***Avoid operating your mower on side hills of over 5 degrees,
inclines of over 10 degrees,
and declines of over 15 degrees.***

SECTION 4: MOWER MAINTENANCE

***Check each and provide maintenance when needed.*

DAILY

- 4.1 Check Engine Oil
- 4.2 Check Engine Air Filter
- 4.3 Tire Pressure
- 4.4 Inspect Blades

Within FIRST five hours of usage, change engine oil and filter

EVERY 30 HOURS OF USAGE

- 4.5 Grease Machine

EVERY 50 HOURS OF USAGE

- 4.6 Change Engine Oil and Filters

Check filters once a year if under 50 hours

Check air and fuel filters more often in dry, dusty conditions

Within FIRST 50 hours of usage, change hydraulic oil and filters

EVERY 250 HOURS OF USAGE

- 4.7 Change Hydraulic Fluid and Filters
- 4.8 Refer to manufacturer manual for specific information on maintenance schedules.

SECTION 5: MOWER STORAGE & TRANSPORTATION

- 5.1 Keep machine from collecting debris by storing in a covered area while not in use.
- 5.2 Fuel can harm your machine if left for more than 30 days without changing, especially if the fuel contains ethanol. Never use fuel with more than 10% ethanol by volume. E-15 is not permitted.
- 5.3 Disconnect the negative battery cable when machine will be stored for more than 30 days.
- 5.4 Always secure machine properly when transporting machine.
- 5.5 Do not load machine on trailer with blades engaged.
- 5.6 Do not use ramps to load the machine.
- 5.7 Make sure Parking Brake is in “up” position.
- 5.8 In wet conditions tires may spin while loading / unloading. If necessary, wait for dry conditions before loading / unloading.
- 5.9 Make sure mode of transportation is suitable to bear the weight of mower.
- 5.10 Deck height should be set at maximum before attempting to load.
- 5.11 Secure mower with at least two straps capable of securing weight of mower.



SECTION 6: TROUBLESHOOTING

- 6.1 **Q:** *How do I prevent an uneven cutting pattern and increase the quality of cut?*
- 6.1 **A:** Check tire pressure, check blade sharpness (replace blades or sharpen at least once per year or when needed), make sure blades are tightened properly, check spring and belt tension, check the underside of the deck to ensure the mower deck is free of grass build-up and debris, make sure your machine is at full throttle, and vary your mowing pattern each time you cut your grass.
- 6.2 **Q:** *What should I do if my mower won't start?*
- 6.2 **A:** Check battery charge and connection (grounds), check your fuel (make sure fuel is less than 30 days old and contains no water), make sure your spark plug is in good condition and spark plug wire is attached, and make sure air filter is clean (a dirty filter makes it more difficult for the engine to draw air). Check for broken wires or bad connections.
- 6.3 **Q:** *What should I do if the blades won't engage?*
- 6.3 **A:** Make sure the safety switch is plugged in on the bottom of seat. Check the underside of the PTO engager to ensure the plug is secure at switch. Also check PTO fuse underneath operator console (10amps)
- 6.4 **Q:** *What type of fuel is recommended for my mower?*
- 6.4 **A:** We recommend that you use a name brand fuel to ensure quality. Use fuel with an octane rating near 87. Higher octane fuels offer no benefit. Only fuels with an ethanol content of 10% or less may be used. E-15 is not permitted.
- 6.5 **Q:** *Do you offer touch-up paint for your mowers?*
- 6.5 **A:** Touch-up paint is available. Contact your local dealer for more information.
- 6.6 **Q:** *How durable is the electric deck lift?*
- 6.6 **A:** The actuator which controls the deck height is designed for moving loads of up to 1000 pounds and has a static holding capability which exceeds 3,000 pounds. Our ¼" deck weighs approximately 250 pounds which is only 25% of working capability. If deck lift will not operate, check fuse located underneath operator console (15amp).

SECTION 7: CONTROLS

- 7.1 **Ignition Switch**—Bad Boy Mowers have a three position ignition switch: off, run, and start. With key inserted, rotate it clockwise to START position and release key when engine starts, and switch will automatically return to the RUN position.
- 7.2 **Throttle Control**—A cable is connected to the engine throttle for controlling engine speed. Move lever forward to increase engine rpm, move lever backward to decrease engine rpm.
- 7.3 **Pre-Heat Button**—Before starting engine push to pre-heat for easier starting.
- 7.4 **Control Levers**—These levers control the mower's speed, direction, and neutral lock. These levers are used to steer, accelerate, decelerate and change direction. (Drive Arms)
- 7.5 **Blade Engage Switch**—This switch engages the blades. Pull the switch up to engage the blades and push the switch down to disengage the blades.
- 7.6 **Deck Lift Control**—The deck lift switch is used to raise and lower the deck. Pull the switch backwards to raise the deck and push the switch forward to lower the deck.

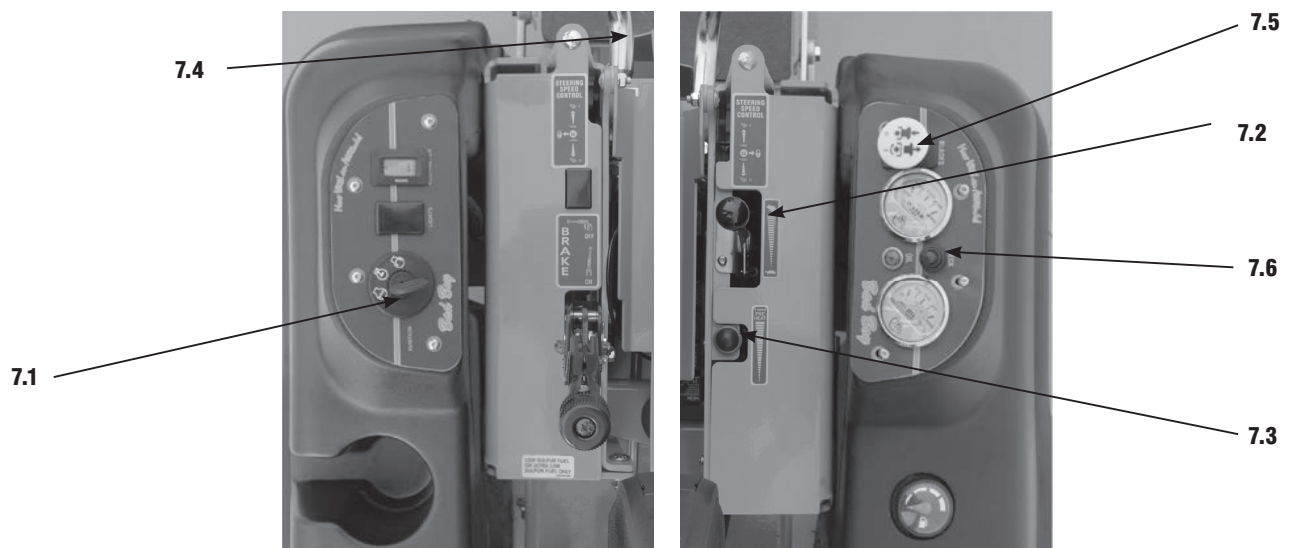



SECTION 8: MOVING INOPERABLE MOWER

- 8.1 Do not tow machine. Use a winch to load on a trailer for transporting.
- 8.2 **ATTENTION:** RETURN BYPASS VALVES TO OPERATING POSITION BEFORE RUNNING MOWER FOLLOWING REPAIRS.
- 8.3 If it is necessary to move mower when the engine is inoperable, the hydraulic drive pumps are equipped with bypass valves. Before moving the mower, turn the bypass valves counterclockwise one-half to one revolution. The valve stems on each pump are located near the top and are identified as a hex stud.
- 8.4 Your Bad Boy Mower Weighs: **DIESEL SERIES:** **1607—1935 lbs**
**** Weights fluctuate with the addition of accessories.*
- 8.5 As you can see by the weights of the machines, you shouldn't ever try to push or pull a Bad Boy Mower by hand. This could cause serious bodily injury.
- 8.6 Hopefully, you'll never need to use this section of the manual. However, if you do, use extreme caution when moving machine!

SECTION 9: INSTRUMENTATION

- 9.1 **Electronic Hour Meter**—Registers Hour increments up to 9,999.9 total hours. This meter records the cumulative time the engine is running.

SECTION 10: MOWER BLADE MAINTENANCE

- 10.1 Check mower blades after each use. This is essential for maintaining well-groomed turf. Keep the blades sharp. If a dull blade is used for cutting, the grass will tear rather than cut. This could damage the grass leaving a brown frayed top on the grass within a few hours. A dull blade will also require more power from the engine.
- 10.2 NEVER attempt to straighten a bent blade by heating. NEVER attempt to weld a cracked blade. The blades can break and cause serious injury or death.
- 10.3 NEVER work with blades while engine is running or deck clutch is engaged.
- 10.4 ALWAYS place deck clutch in DISENGAGE position while performing maintenance.
- 10.5 Use blocks when you MUST work under mower.
- 10.6 ALWAYS wear thick gloves when handling blades.
- 10.7 ALWAYS check for blade damage if mower strikes rock, branch, or other objects that could potentially damage the blade.

***(REMEMBER: NEVER CHECK BLADE WHILE ENGINE IS ON!
NEVER CHECK BLADES WHILE BLADES ARE ENGAGED!)***

SECTION 11: GREASING THE BEARINGS

- 11.1 Park the machine on a level surface and disengage the blade control switch.
- 11.2 Move the motion control levers outward to the neutral position, engage parking brake, stop the engine, remove the key, and wait for all moving parts to stop before leaving the operating position.
- 11.3 Grease Type: NLGI grade #2 multi-purpose gun grease. Grease the front caster pivots. 11.4 Clean the grease fittings with a cloth. Scrape any paint off the front of the fitting(s).
- 11.5 Connect a grease gun to each fitting. Pump grease in fittings until grease begins to seep out of the bearings. Wipe up excess grease.
- 11.6 Refer to service manual section for grease fitting locations.



HOW TO CHOOSE THE RIGHT BLADE

Essentially there are only TWO basic styles of mowing blades used or approved for use on our current products:

- 1) The standard style of mowing blade is essentially designed for cutting grass and effectively discharging the clippings out from the deck to fall onto the lawn or to be captured in a grass collection system. Standard blades are also referred to as “2-in-1” (discharging & bagging) or “high-lift” blades (because they are designed to create a higher-lifting airflow).
- 2) Mulching blades generally have a more curved style surface and frequently include extra cutting surfaces along the blade edges. These blades may also come in a “+” design (which is actually two individual blades arranged in a perpendicular fashion to enhance mulching). The “+” blades are usually found on older style mowers; newer ones utilize blades with more advanced mulching technology. Mulching blades may also be referred to as “3-in-1” (mulching, discharging & bagging) or “all-purpose” blades.

Bear in mind that the re-circulating airflow design of 3/1 blades makes them less efficient at discharging grass clippings than a standard 2/1 blade. As with most all-purpose tools, there is some give and take as opposed to using a tool designed for a more specific purpose.

If you’re experiencing less-than-desired cutting or discharging performance with a 3/1 blade, you may want to check into using a 2/1 blade. Conversely, if you’re using a 2/1 blade and want to mulch clippings, you should see about the availability of mulching blades or a mulching kit.*

The type of blade installed on a new mower is a decision the retailer makes for each model of mower, based on the expected needs of most customers. If you’re unsure of which blade is on a particular model, inspect the blade. Blades have part numbers stamped into them. Then compare these part numbers with the unit’s Operator’s Manual or Parts List.

It is true there are many other styles of blades available. But since we don’t manufacture or recommend using these other aftermarket styles, we will leave them out of this discussion. Should you want more information on special application or aftermarket blades, you should contact the companies that make these products. NOTE: Customers using non-OEM blades do so at their own risk. The use of unapproved (non-OEM) blades may void any or all of the mower and engine factory warranties.

* **MULCHING KITS** – These generally consist of mulching blades and a mulching plug (which closes off the discharge opening to keep the clippings contained under the deck for re-cutting) plus any necessary hardware for installation. Please check with your parts distributor regarding the contents of a particular mulching kit.

MOWING TIPS:

- Mow header strips at the ends of the lawn and around flower beds first. Make them wide enough that you can turn the mower around in the already mown section. Then mow back and forth between these header strips overlapping each lap by about 1/8 the width of the mower's deck.
- Don't cut your grass too short, particular for cool season grasses. Higher heights usually provide for a deeper root system, looks better, and is less likely to have weeds invading, particularly crabgrass.
- Don't remove any more than one third of the grass leaf at any one cutting. If circumstances arise that a lawn gets too tall and you just have to lop off a bunch to get caught up, bite the bullet and break it down into several mowings to get caught up with 3 or so days between cuttings.
- **NEVER SCALP YOUR LAWN.** Scalping severely damages the root system to such a degree that it may die.
- Avoid mowing when the grass is wet or when it's dark
- Avoid throwing grass clippings into the street and driveway where they can be washed into the sewer system. After mowing, clean up driveway and walkways.
- When mowing remove only a third with each cutting (except for the first mowing of the season when it's ok to remove more). You can safely leave clippings that will quickly decompose and add nutrients back into the soil. Contrary to popular opinion, grass clippings do not add to thatch buildup. Grass blades are made up of about 75% water.
- Mow your lawn in a different direction with each mowing, especially with lawns of shorter grass types. Altering the direction ensures a more even cut since grass blades will grow more erect and less likely to develop into a set pattern.
- Keep your mower's blade sharp, which means having it sharpened several times during the mowing season. Keep several blades around so you'll always have a sharp one on hand. Sharp blades cut the grass cleanly and help mulch clippings into small pieces which break down quickly.
- Don't forget to change your mower's oil at least once during the mowing season. For brand new mowers, change the oil after about 5 hours of operation during the initial break-in period.
- At the end of the mowing season use a fuel stabilizer in the remaining gasoline
- In the spring, don't use that old gas unless you properly used a fuel stabilizer, it can cause a number of problems. Better to use fresh gasoline to begin the new mowing season.
- **Leaf blade A** demonstrates what a leaf blade should look like after mowing with a sharp blade.
- **Leaf blade B** demonstrates a leaf blade that was injured by a dull mower blade.
- **Leaf blade C** was cut by the mower but indicates that the mower blade is not sharp enough. The shredded white tissue protruding from the leaf blades C and D is the vascular tissue of the plant.
- **Leaf blade D** has been mown for quite some time with a dull mower blade.

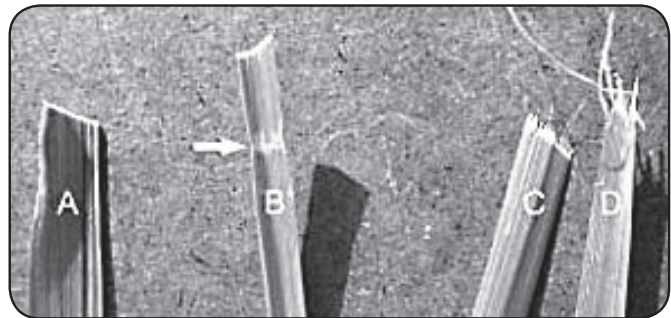

To bag or mulch?

Grass clippings do not contribute to thatch buildup or increase the chances of disease. If you mow your lawn at the right height, without removing any more than 1/3 of it's total height, clippings will quickly breakdown without a trace. These clippings contribute additional nitrogen and other nutrients to the soil and supply it with additional organic materials. Clippings from a 1000 sq. ft. lawn can add as much as 1 - 2 pounds of nitrogen back into the soil.

If you have a compost pile, then you may want to bag your clippings occasionally to add much needed green-matter to the compost pile. Make sure it is mixed thoroughly with brown matter to avoid a strong ammonia odor. **DO NOT COMPOST CLIPPINGS** after applying any weed control or weed-feed type product. Before adding clippings to the compost pile wait at least 3 mowings after these products have been applied.



SERVICE SECTION

SECTION 1: HYDROSTATIC SYSTEM

To change hydro oil on Diesel models, remove oil return lines from top of hydro tank and place them in a disposable oil container. Start and run mower until oil level is reduced down to about 2" of oil remaining in the tank. Do not allow air to enter the oil lines in the bottom of the tank. Keep in mind that only about 75% of the hydro oil can be changed at a time. Use only 20w50 motor oil in the hydro system. (Conventional or synthetic oil may be used) Bad Boy recommends that the hydro oil and filters be changed within the first 50 hours of usage and every 500 hours thereafter or once a year.

(Diesel Models)

Change hydro oil filters by unscrewing them from the filter head. Fill new filters with 20w50 motor oil before installing. Use only Bad Boy replacement filters. Using any other filter will result in damage to the hydro system and void the warranty.

Once the system is refilled with oil, lift rear of mower until tires are off the ground. Start engine, release parking brake, stay clear of moving rear tires, loosen bypass bolt $\frac{1}{2}$ to $\frac{3}{4}$ turns, move drive arms forward and backward 4 to 6 times slowly. This will purge the air from the system. (the bypass bolt has a hole drilled through the side of the bolt head). This valve also serves as a neutral for moving the mower without the engine running.

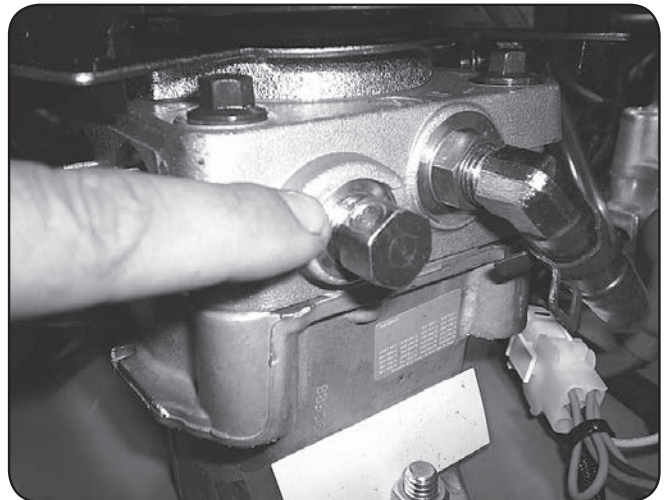
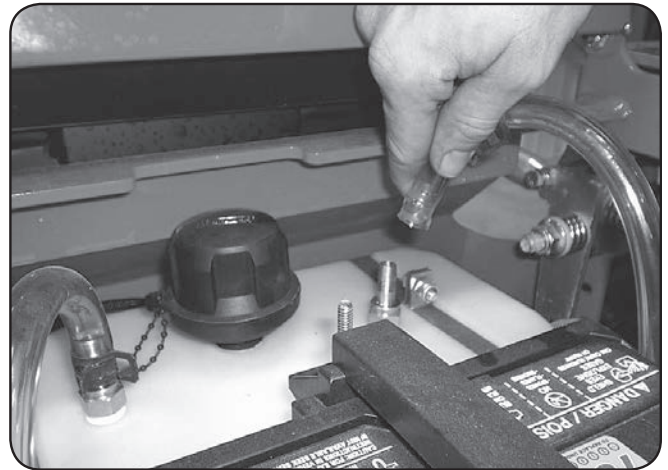

SECTION 2: DRIVE BELT

Shown above is a typical pump belt tensioner for Outlaw models.

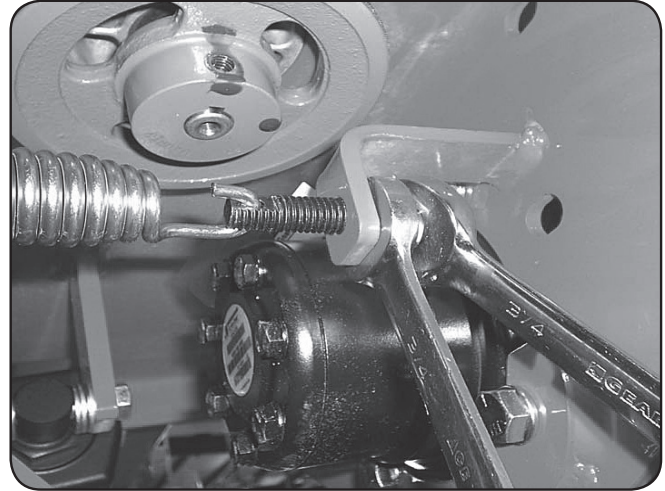

Factory setting is about .030" (about the thickness of a credit card) between coils as shown.

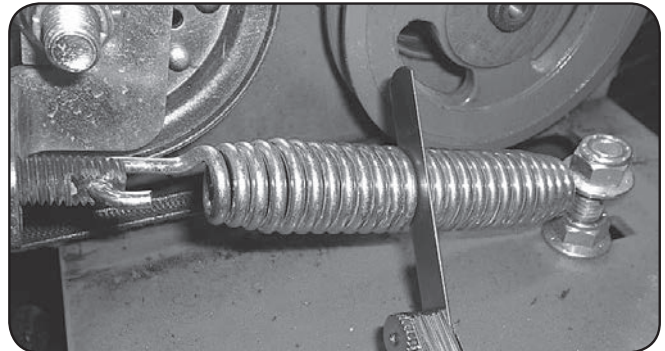

Shown to the right is a typical pump belt layout for most models.

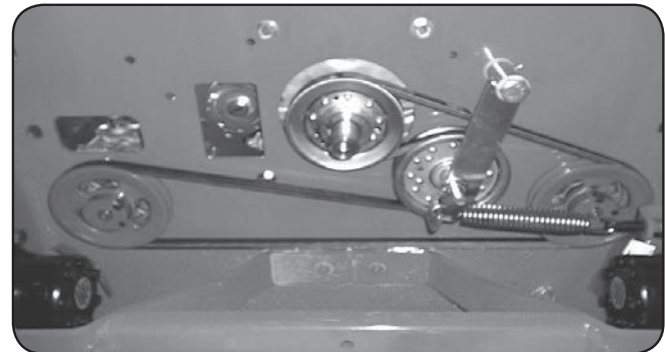

SECTION 3: ENGINE

When servicing the fuel system on the CAT Diesel, it is necessary to purge the air from the system by loosening the 9/16" bolt on top of the fuel filter and pumping the fuel bulb (located underneath the radiator) until air bubbles are no longer visible.

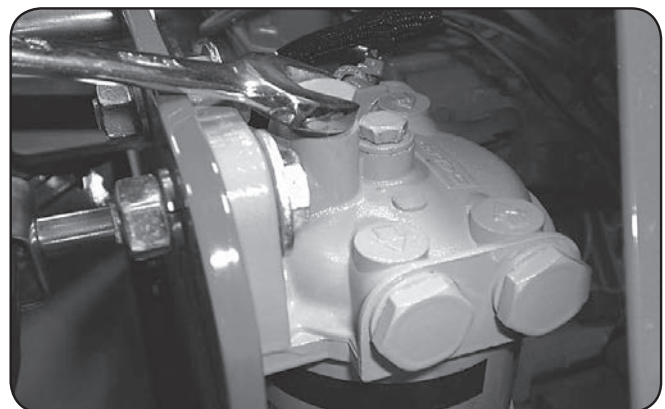

Remove and inspect air cleaner weekly. (More often in dusty conditions). Do not blow filter out with air pressure, this will cause the filter to be filled with tiny holes that will allow dirt to enter. Instead, tap filter on side to remove any debris. Replace at least once a year, more often in dusty conditions.

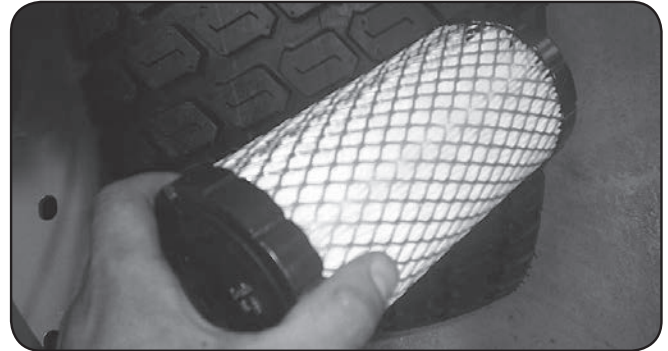

Torque the clutch bolt to 50 ft. lbs. on all models. Retorque at every oil change.

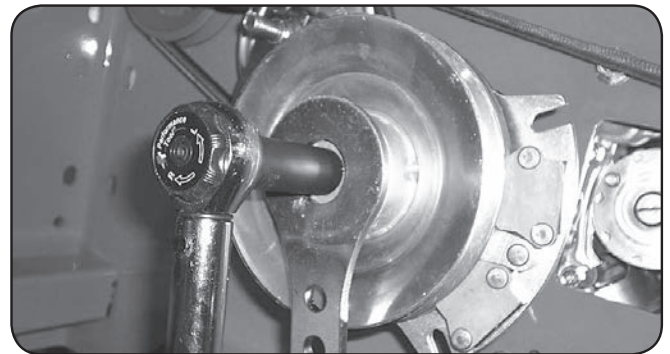

Keep radiator screen clean and free of debris on liquid cooled models. Check screen hourly during dry conditions. Slide radiator screen up to remove.

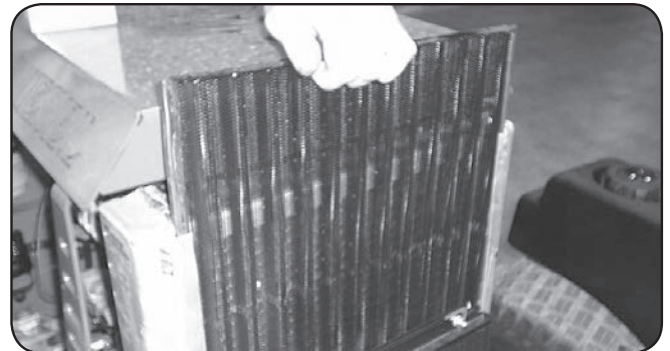

SECTION 4: ELECTRICAL SYSTEM

On most larger commercial engines (27 hp and up), the 25 amp main fuse is located about 3" from the starter on the engine. (shown in first image on right). On smaller commercial and light duty commercial mowers, the 25 amp main fuse is located just behind the battery connected to the starter solenoid. (Shown in second image on right).

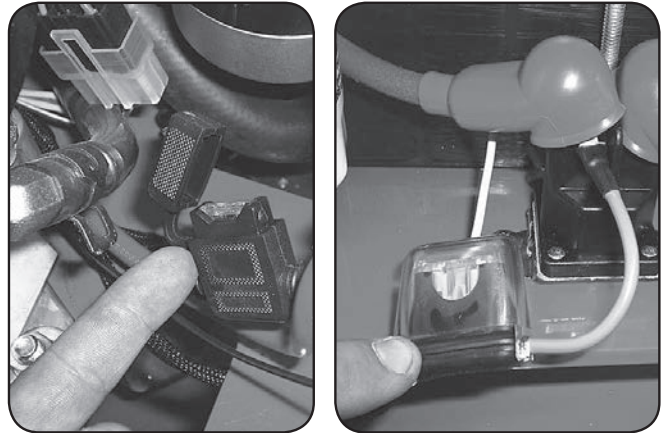

Always check the condition of the wiring harness ground cable. Ensure that the ground is connected, clean, and tight. On most models, the ground wire is connected to the negative side of the battery.

Check the condition and connection of the relays located under the seat. Ensure that they are clean and connected. Make sure that wire terminal ends have not been pushed out of the relay block.

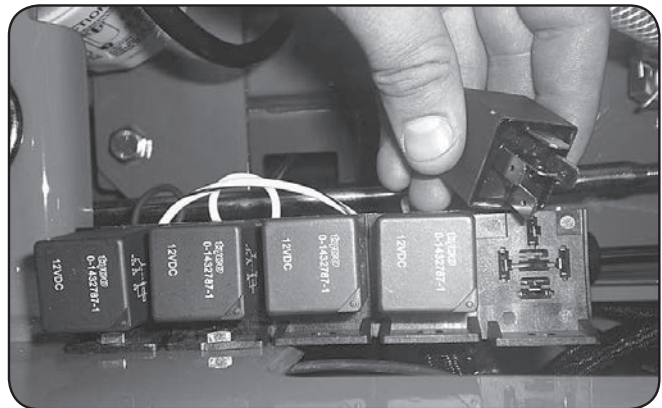

On most models, the red wire coming out of the engine is the charging wire from the alternator. Check for 13.6—14.2 volts DC at this wire with engine at full throttle.

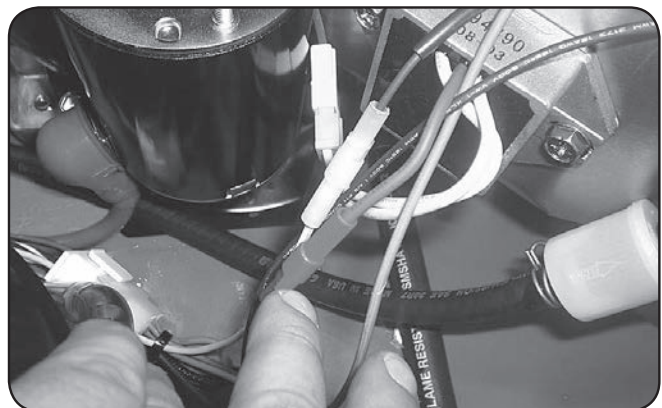

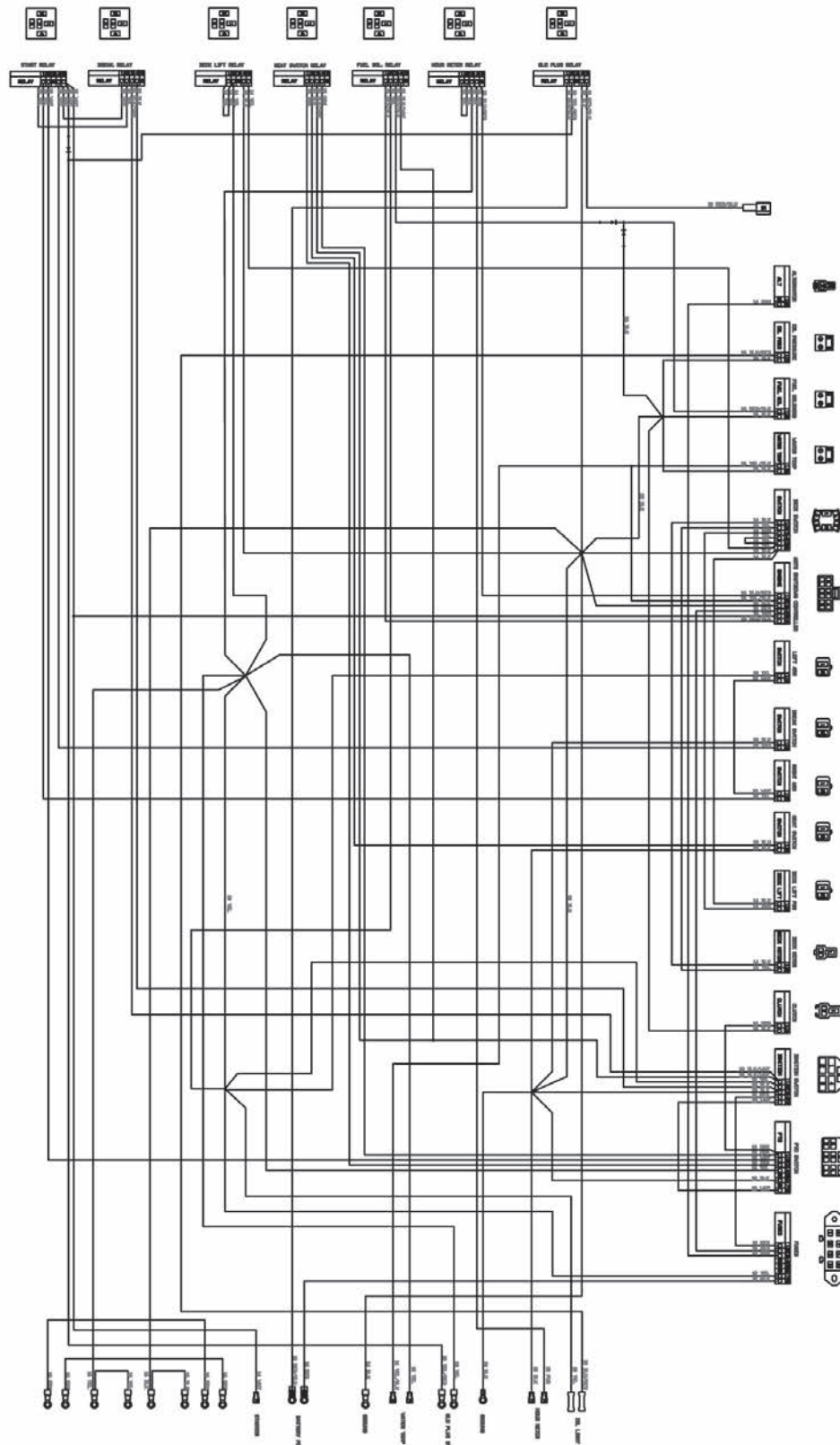

THIS DOCUMENT IS UNCLASSIFIED
DATE 10-28-2010 BY 60322 UCBAW/STP
FORMERLY RELEASING AUTHORITY DERIVED FROM
E.O. 13526, 13526-1
DATE 08-14-2011 BY 60322 UCBAW/STP

THESE DOCUMENTS ARE THE PROPERTY OF ELECTREX, INC. AND ARE TO BE RETURNED TO ELECTREX, INC. UPON REQUEST.
DATE 08-14-2011 BY 60322 UCBAW/STP

FOR FURTHER INFORMATION CONTACT: ELECTREX, INC.
10000 W. 127TH AVE., SUITE 200, WESTMINSTER, CO 80234
TEL: 303.440.0113 FAX: 303.440.0114
WWW.ELECTREX.COM

ELECTREX, INC.
HYDROFORM IN
CUSTOMER: JIMMY KENT
TRUCK #147-386-30
SNG TITLE: 30650247-00
CNR P/N: 30650247-00
DATE: 08-14-2011 BY: 60322 UCBAW/STP
DRAWN BY: JIMMY KENT DATE: 08/14/11

SECTION 5: FRAME

For non-suspension models, torque front fork castle nut to 40 ft.lbs. Be sure to spin the fork while torquing the nut to ensure that no bearing damage is done. The torque for suspension forks should be 50 ft. lbs.

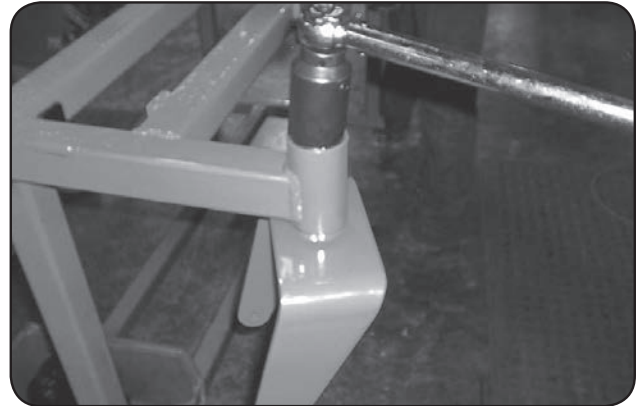

Torque rear wheel lugs to 65-75 ft. lbs.
Re-torque at every oil change.



There is one grease fitting in each front wheel and one in each front caster bearing housing. Grease at every engine oil change.

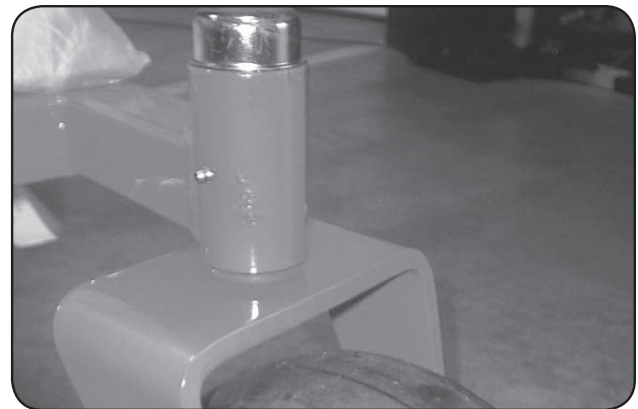

There is one grease fitting on each of the actuator bar pillow blocks located under the fuel tanks. Grease twice a season.

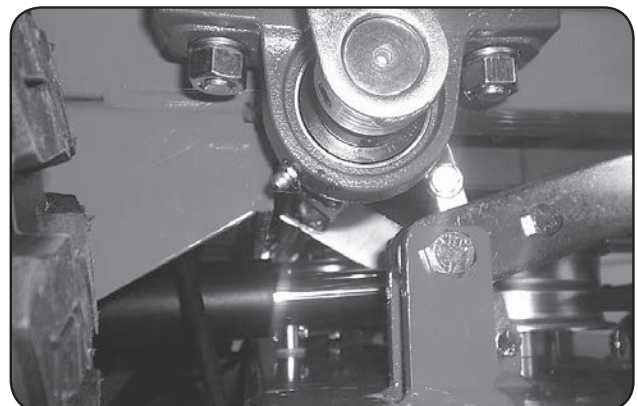



The pump belt tensioner is located under the engine and has a grease fitting at its pivot point. Grease at every engine oil change.

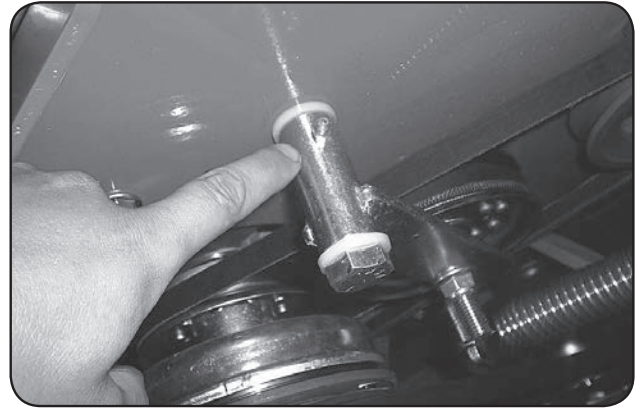

The deck belt tensioner is located at the rear of the deck and has a grease fitting on its pivot point. Grease at every engine oil change.

The control arm blocks have grease fittings located on the top of each block. Grease one time a year.

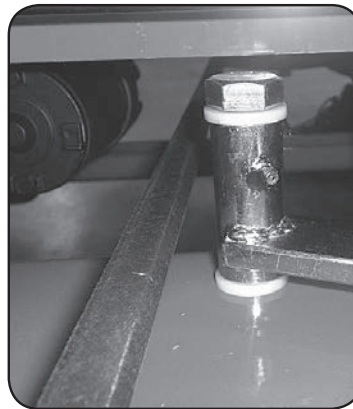

SECTION 6: CUTTING DECK

To remove the deck belt, lift up on the belt while rotating the pulley to roll the belt up and off of the pulley. (be sure not to get your fingers between belt and pulley).



To check the level of the deck, start on a flat surface and set the air pressure in all four tires. Raise the deck up, and measure all four corners of the deck to see if it is level from left to right and front to back. All decks should be level from left to right and have a 1/8" pitch down in the front.

If deck adjustments are necessary, start with the chain length adjusters. These adjusters affect the overall height of the deck and the level from left to right.

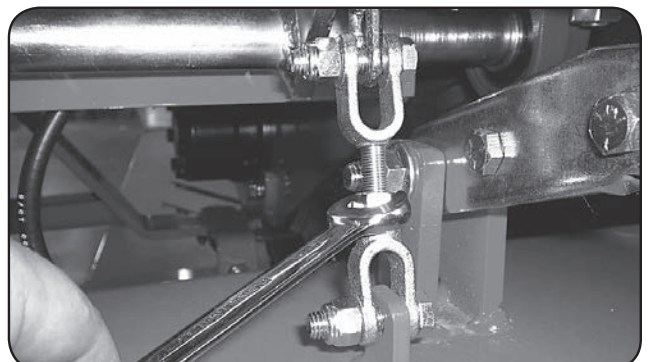

The large turn buckles on the front of the deck only affect the pitch of the deck or the level from front to back.

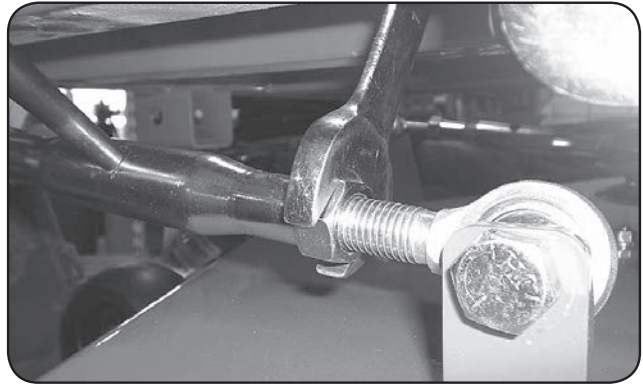

The deck spring tension is critical. If the tension is too much, it will cause the spring to break. If too loose, the belt can jump off or slip on the pulleys and cause a cut quality issue. With the deck up, the spring coil gap should be about .025" - .030" (about the thickness of a credit card). Spring tension adjustments can be made by sliding the bolt shown above forward or backward in the slot of the deck.

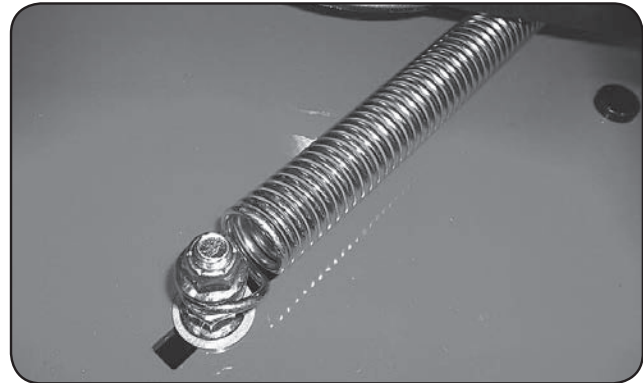

The condition of the blades can drastically affect the cut quality of the mower deck. Replace as necessary. These blades were used considerably too long. Resharpener is recommended by professionals only to determine when the blade needs to be replaced and because of the need for rebalancing.



To change blades, it may be easier to use a piece of wood to keep the blade from turning so that the bolt can be loosened.

Bolts used have standard threads. Re-torque the blade bolts to 90-110 lbs. The blade spindles contain a sealed ball bearing in the top and bottom of the spindle. The bearings

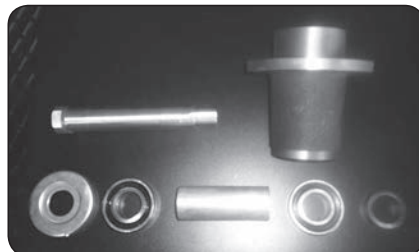

are replaceable for a more cost effective repair.



PARTS SECTION

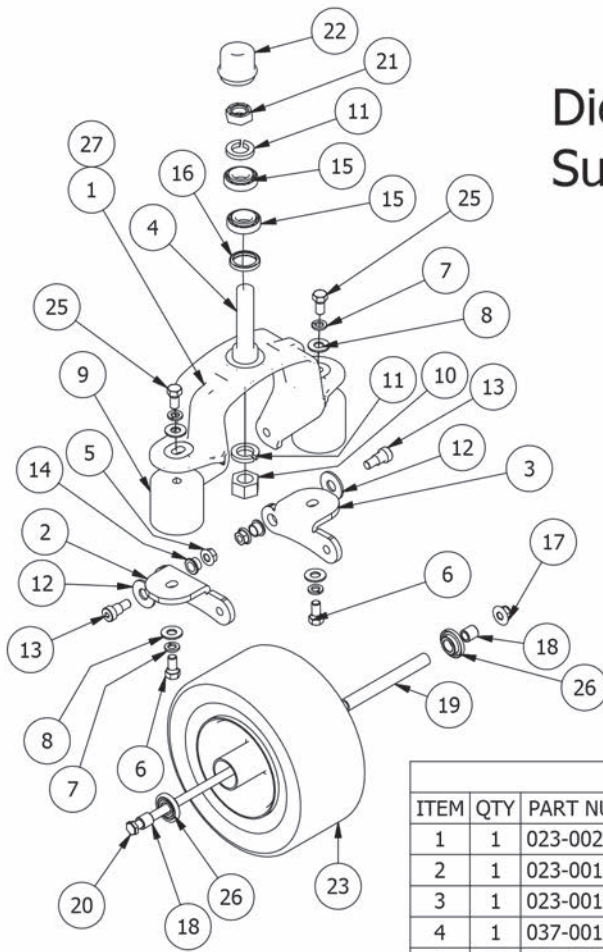

Diesel CAT Suspension Fork Assembly

Suspension Fork Assembly			
ITEM	QTY	PART NUMBER	DESCRIPTION
1	1	023-0020-00	Suspension Fork Top/Side Combo
2	1	023-0012-00	Suspension Fork - Bottom Left
3	1	023-0013-00	Suspension Fork - Bottom Right
4	1	037-0010-00	Front Suspension Fork Spindle
5	2	013-5300-00	1/2" Flange Nut
6	2	018-2030-00	1/2" x 1" Hex Bolt
7	4	019-5007-00	1/2" Lock Washer
8	4	019-5702-00	1/2" Washer (Grade 8)
9	2	032-9002-00	Vibration Mount- Red Dot
10	1	013-6016-00	1" Fine Thread Nut
11	2	019-3000-00	1" Lock Washer
12	2	019-5038-00	5/8" Flat Washer
13	2	018-3001-00	5/8" x 5/8" Shoulder Bolt
14	2	032-5052-00	Bronze Bushing - SF - 2024-8
15	2	010-7001-00	Bearing
16	1	012-7003-00	Seal
17	1	013-8050-00	1/2-13 Nylon Flange Nut-Orange
18	2	025-5203-00	3/4 OD x 1/2 ID x 3\4 Length
19	1	025-5202-00	Front Wheel Spanner
20	1	018-3002-00	1/2" x 10" Bolt
21	1	013-9004-00	1" Fine Thread 1/2 Nut
22	1	014-7005-00	Dust Cover
23	1	022-3070-00	13 x 6.50 - No-Flat Large Bore Orange front Assembly
26	2	022-7010-00	1-3/4" Bearing-Large Bore Front Rim
25	2	018-2080-00	1/2-13 x 1-1/4 Hex Bolt
27	1	023-7915-98	Suspension Fork Assembly

Diesel Drive Arms

Items Per Side

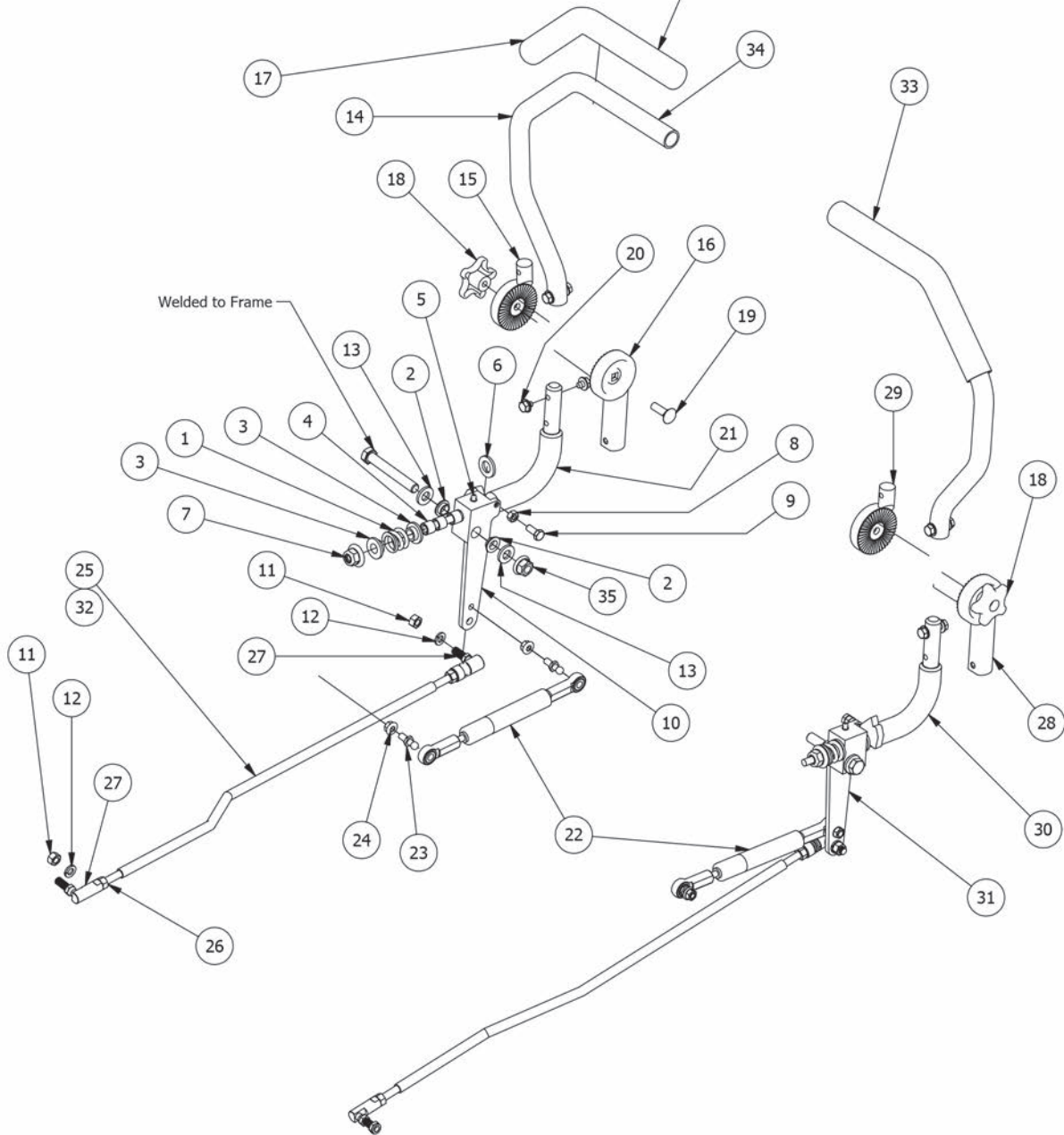



Diesel Drive arms			
ITEM	QTY	PART NUMBER	DESCRIPTION
1	1	034-8025-00	Drive Lever Spring
2	2	032-5055-00	Bushing for 2012 Drive Arms
3	2	019-8027-00	.515 ID Nylon Shoulder Washer
4	3	032-8024-00	.507 ID Nylon Bushing
5	2	024-6034-00	1/4" Drive in Grease Fitting
6	1	019-6017-00	.635 ID Plastic Washer
7	1	013-8050-00	1/2-13 Nylon Flange Nut-Orange
8	1	013-8043-00	5/16" Nut
9	1	018-8063-00	5/16" x 3/4" Hex Bolt
10	1	027-8819-00	Drive Arm Lever Housing (Left)
11	2	013-6051-00	3/8" Fine Threaded Jam Nut
12	2	019-5037-00	3/8" Lock Washer
13	2	019-7000-00	.505x1x .125 Oil Impregnated washer
14	1	031-9010-00	Upper Tube-Adjustable Steering
15	1	031-9017-00	Upper adjuster-Steering Arm- Left
16	1	031-9014-00	Lower Adjuster - Steering Arm- Left
17	1	069-4010-00	Black Steering Grip
18	2	045-5000-00	Black Knob for Adjustable Steering Arm
19	1	018-5043-00	3/8" x 1 1/4" Carriage Bolt
20	4	018-2020-00	5/16-18 1/2 HWH Bolt-Steering
21	1	031-9020-00	Steering Arm Elbow - Left
22	2	087-8080-00	Damper
23	2	018-2050-00	10mm Damper Ball Stud-Steering
24	2	013-9002-00	5/16" Flange Nut
25	1	035-6060-00	Steering Push Rod - 28Hp Diesel Push Rod
26	2	013-6051-00	3/8" Fine Threaded Jam Nut
27	2	099-6046-00	3/8-24 Ball Joint
28	1	031-9015-00	Lower Adjuster - Steering Arm- Right
29	1	031-9016-00	Upper Adjust Steering Arm- Right
30	1	031-9025-00	Steering Arm Elbow - Right
31	1	027-8820-00	Drive Arm Lever Housing Right
32	1	035-6050-00	Steering Push Rod - 35HP Diesel
33	1	031-9050-00	Adjustable Steering Arm-Right Assembly-Componets 14,17,18,19,20,28,29
34	1	031-9000-00	Adjustable Steering Arm-Left Assembly-Componets 14,15,16,17,18,19,20
35	1	013-0085-00	1/2-13 Hex Flange (GR.G) ZC

Diesel Tanks

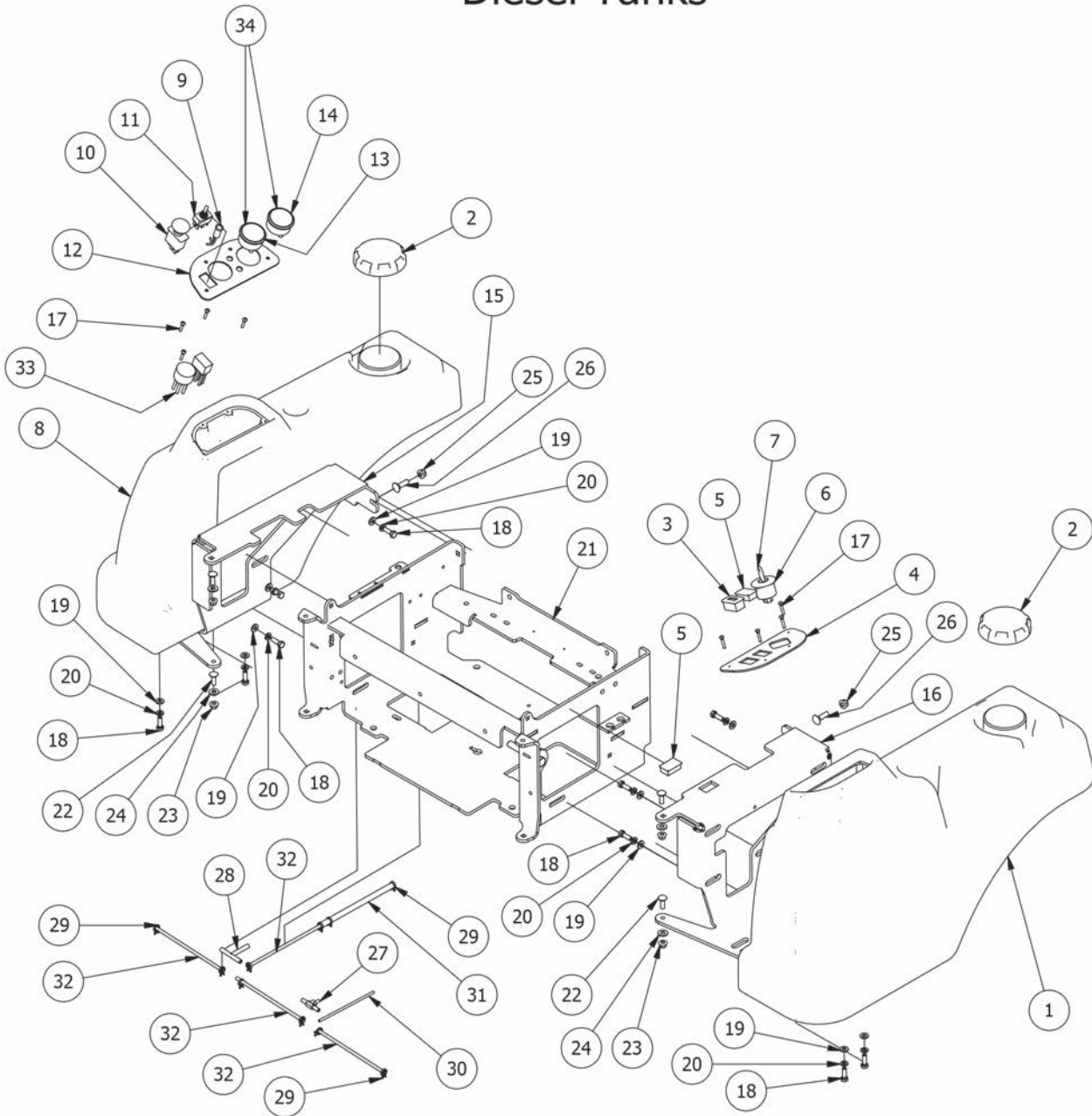



Diesel Tanks Assembly			
ITEM	QTY	PART NUMBER	DESCRIPTION
1	1	067-3000-00	Left Fuel Tank with Fender
2	2	066-8090-00	Diesel Fuel Cap -3.5 inch Neck
3	1	083-4014-00	Hour Meter
4	1	079-3402-00	Control Panel (Left)
5	2	018-1040-00	Light Plug
6	1	077-8076-00	Ignition Switch
7	1	042-9000-00	Ignition Key
8	1	067-3001-00	Right Fuel Tank with Fender
9	1	089-1000-00	Oil Light
10	1	056-8058-00	PTO Engager
11	1	078-8077-00	Deck Lift Joystick
12	1	079-3405-00	Diesel Control Panel Right 2012
13	1	086-7001-00	2" Water Temperature Gauge
14	1	086-7000-00	2" Oil Pressure Gauge
15	1	031-2010-00	Left Tank Support AOS
16	1	031-2011-00	Right Tank Support AOS
17	8	018-2015-00	10-32 x 1 Button Head Bolt
18	10	018-2007-00	5/16" x 1" Bolt
19	10	019-8044-00	5/16" Flat Washer
20	10	019-8051-00	5/16" Lock Washer
21	1	080-7000-00	Diesel Seat Frame
22	4	018-8065-00	5/16" x 1" Carriage Bolt
23	4	013-9002-00	5/16" Flange Nut
24	4	019-6042-00	.360 ID Plastic Washer
25	2	013-5202-00	3/8" Nylock Flange Nut
26	2	018-5043-00	3/8" x 1 1/4" Carriage Bolt
27	1	073-2000-00	Brass fuel line T
28	1	073-8068-00	fuel line T
29	11	072-8069-00	1/4 fuel clamp
30	1	051-8068-00	3/16 Fuel Line
31	1	051-8075-00	5/16" fuel line hose
32	4	051-8067-00	1/4" fuel line hose
33	1	086-0035-00	Wiring Harness -35 & 28 Diesel
34	2	086-7002-00	Pigtail-2" Faria Gauge -2012 & up (Used For the water and Oil Gauges)

Outlaw Compact Diesel Frame

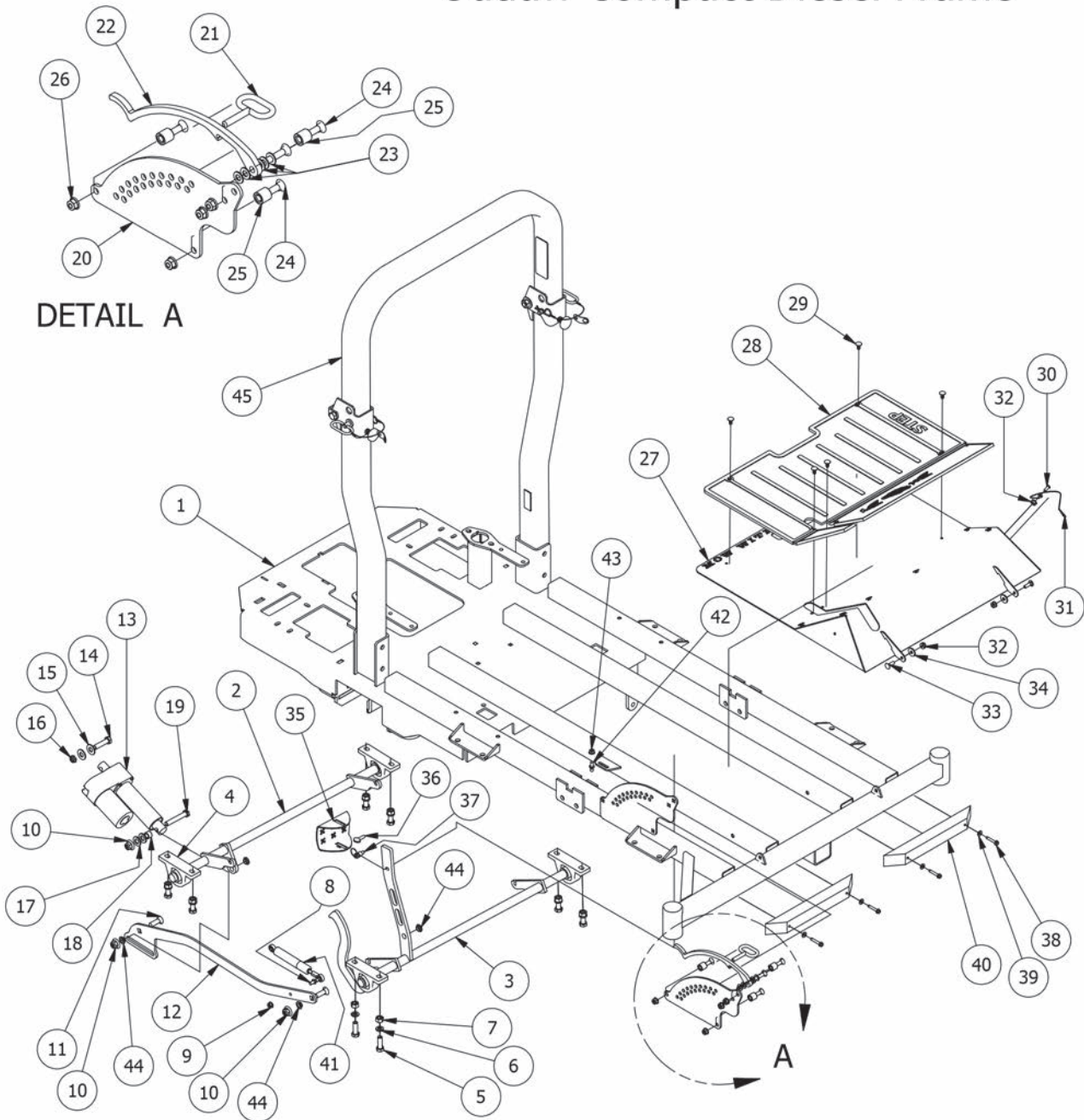



Outlaw Diesel Frame, Actuator, Floor Board, and Height Indicator			
ITEM	QTY	PART NUMBER	DESCRIPTION
1	1	070-5570-00	Outlaw Diesel Frame 2012
2	1	028-6020-00	Outlaw Actuator Bar (Rear)
3	1	028-6010-00	Outlaw Front Actuator Bar Assembly
4	4	017-7008-00	pillow block 2bolt sealmaster
5	8	018-5006-00	1/2" x 1 1/2" Hex Bolt
6	8	019-5007-00	1/2" Lock Washer
7	8	013-7018-00	1/2" Hex Nut
8	1	018-2050-00	10mm Damper Ball Stud-Steering
9	1	013-9002-00	5/16" Flange Nut
10	3	013-8050-00	1/2-13 Nylon Flange Nut-Orange
11	2	018-0008-00	1/2 x 1-1/2 Carriage Bolt
12	1	028-6055-00	Outlaw Susp Frame Linkage Bar
13	1	035-7033-00	Actuator
14	1	018-5049-00	1/2-13x2 GR 5 Hex Bolt
15	2	019-5702-00	1/2" Washer (Grade 8)
16	1	018-4010-00	1/2" Nylcock Nut (1/2 Jam)
17	2	019-6017-00	.635 ID Plastic Washer
18	1	025-7036-00	1/2 x 1/2 Spacer
19	1	018-7016-00	1/2-13 x GR 5 Hex Bolt Zinc
20	1	026-2100-00	Outlaw Height Indicator Plate (Outer)
21	1	040-4000-00	Deck height lever pin
22	1	031-0100-00	Outlaw Deck Lever Lock
23	5	019-2003-00	.390 x .750 x .062 Nylon Washer
24	4	018-0009-00	3/8 x 1 3/4 Carriage Bolt
25	3	025-5203-00	3/4 OD x 1/2 ID x 3\4 Length
26	4	013-5202-00	3/8" Nylock Flange Nut
27	1	079-3200-00	Outlaw Diesel Floor Panel
28	1	081-2008-00	Foot Assist Floor Mat
29	11	040-6080-00	Ratchet Fastener
30	1	018-8064-00	1/4" x 5/8" BS C/S 18-8 SS
31	1	064-2006-00	Floor board Cable W/ Swivel Ends
32	3	013-8049-00	5/16-18 Nylon Flange Nut
33	2	018-8065-00	5/16" x 1" Carriage Bolt
34	2	019-6042-00	.360 ID Plastic Washer
35	1	026-0013-00	Outlaw Deck Lift Pedal
36	1	030-0010-00	5/16-18 x1 Thumb Screw Zinc
37	1	040-5000-00	Pull Pin
38	4	030-7039-00	1/4" x 1 1/2" Self Tapping Screw
39	4	019-7040-00	1/4" Flat Washer
40	2	029-7037-00	14" Rubber Bumper
41	1	087-6100-00	250lb Gas Spring - 61" Deck
42	1	018-2050-00	10mm Damper Ball Stud-Steering
43	1	013-9002-00	5/16" Flange Nut w/Serrations
44	4	032-3000-00	Actuator Bar Bushing-SF-1620-4
45	1	089-3050-00	2 X 3 ROPS Fits All 2012 Diesel Models

Diesel Frame

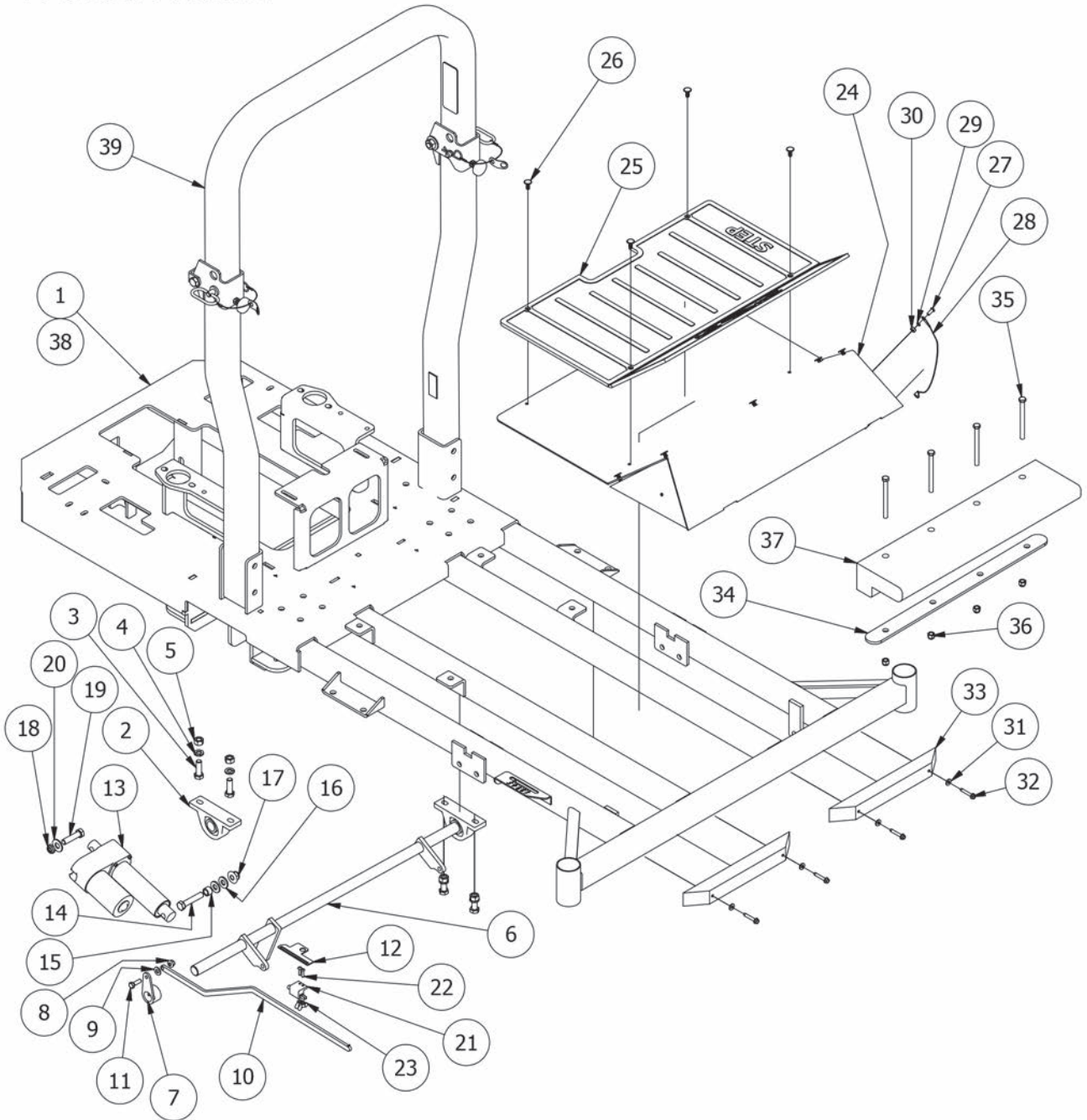



Diesel Frame, Actuator, Floor Board, and Height Indicator			
ITEM	QTY	PART NUMBER	DESCRIPTION
1	1	070-5550-00	Diesel 4cyl 72" Frame
2	2	017-7008-00	pillow block 2bolt sealmaster
3	4	018-5006-00	1/2" x 1 1/2" Hex Bolt
4	4	019-5007-00	1/2" Lock Washer
5	4	013-7018-00	1/2" Hex Nut
6	1	028-7920-00	Actuator Bar
7	1	031-7000-00	Height Indicator Lever
8	1	013-9002-00	5/16" Flange Nut
9	1	019-6042-00	.360 ID Plastic Washer
10	1	028-5203-00	Height Indicator Bar
11	1	018-2007-00	5/16" x 1" Bolt
12	1	039-2008-00	Deck Stop Bracket 2008
13	1	035-7033-00	Actuator
14	1	018-6036-00	1/2" x 2 1/2" Hex Bolt
15	1	025-7036-00	1/2 x 1/2 Spacer
16	2	019-8054-00	.505 Nylon Spacer
17	1	013-8050-00	1/2-13 Nylon Flange Nut-Orange
18	1	018-4010-00	1/2" Nylcock Nut (1/2 Jam)
19	1	018-5049-00	1/2" x 2" Hex Bolt
20	1	019-5702-00	1/2" Washer (Grade 8)
21	1	077-5300-00	Deck Stop Switch
22	2	018-8056-00	1024 x 1" Allenhead Bolt
23	2	013-2000-00	M6x1.0x20MM 8.8 Hex Bolts Zinc
24	1	079-6000-00	Floor Panel
25	1	081-2007-00	AOS Floor Mat
26	9	040-6080-00	Ratchet Fastener-Floorboard
27	1	018-8064-00	1/4" x 5/8" Buttonhead Bolt
28	1	064-2006-00	Floor board Cable W/ Swivel Ends
29	1	019-4008-00	1/4" Lock Washer
30	1	013-8039-00	1/4" Hex Nut
31	4	019-7040-00	1/4" Flat Washer
32	4	030-7039-00	1/4" x 1 1/2" Self Tapping Screw
33	2	029-7037-00	14" Rubber Bumper
34	1	028-1000-00	Diesel Weight Bar Bracket
35	4	018-2005-00	3/8" x 4 1/2" Bolt
36	4	013-5041-00	3/8 Nylock Nut
37	1	088-2000-00	58lb Diesel Weight
38	1	070-5520-00	Diesel 4cyl 61" Frame Suspension
39	1	089-3050-00	2 X 3 ROPS Fits All 2012 Diesel Models

Diesel Seat Frame

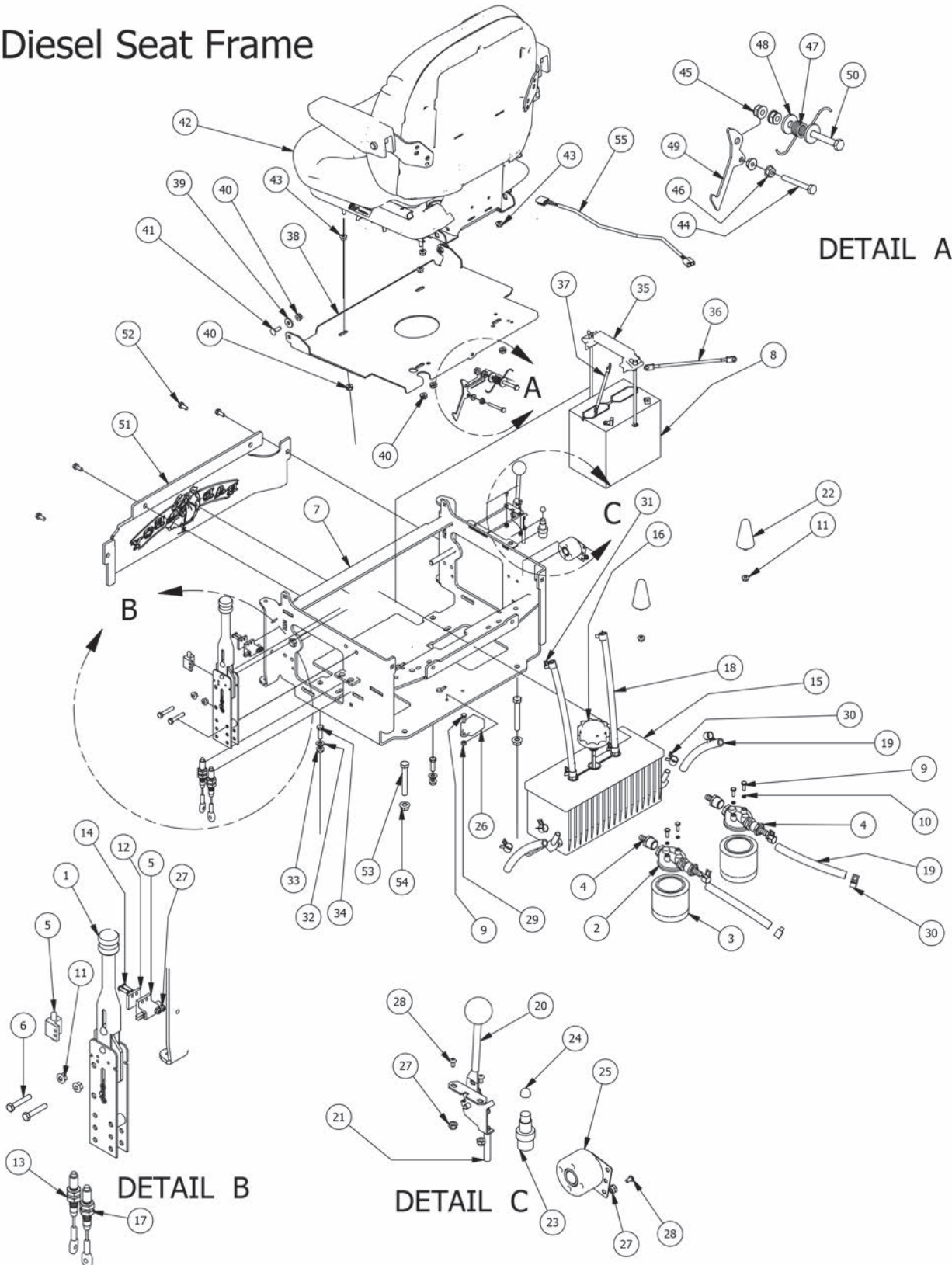



Diesel Seat Frame			
ITEM	QTY	PART NUMBER	DESCRIPTION
1	1	069-8054-00	Hand Brake Assembly
2	2	062-8013-00	Filter Head
3	2	063-8014-00	Hydraulic filter
4	4	024-5050-00	Filter Head Fitting
5	3	77-8073-00	Switch
6	2	018-8059-00	5/16" x 1 3/4" Hex Bolt
7	1	080-7000-00	2007 Diesel Seat Frame
8	1	068-8050-00	Battery - Diesel Models - I51
9	5	018-8052-00	1/4" x 3/4" Hex Bolt
10	5	019-4008-00	1/4" Lock Washer
11	4	013-9002-00	5/16" Flange Nut w/Serrations
12	2	025-6041-00	Switch Block Plastic
13	1	064-8055-00	Short Brake Cable
14	4	018-8056-00	1024 x 1" Allenhead Bolt
15	1	067-2010-00	Aluminum Hydraulic Tank
16	1	066-8050-00	Hydraulic Tank Cap
17	1	064-8056-00	Long Brake Cable
18	2	051-8063-00	3/8" x 32" Clear Hose
19	4	051-8064-00	1/2" x 9 1/4" Braided Hose
20	1	055-8018-00	Throttle - Diesel
21	1	055-8018-75	Diesel Throttle Cable Only
22	2	034-1000-00	Spring Cushion
23	1	077-6000-00	Momentary Start Switch
24	1	014-6000-00	Start Switch Boot - Diesel
25	1	021-8059-00	Heat Warning Piezo Buzzer
26	1	015-0015-00	Auto Shut Down for Cat Diesels
27	7	013-5019-00	#10 Nylock Nut
28	3	018-5200-00	1024 X 5/8" Buttonhead Bolt
29	1	013-8039-00	1/4" Hex Nut
30	8	072-8066-00	1/2 Hose Clamp
31	4	072-8065-00	3/8 hose clamp
32	4	019-5029-00	3/8" Flat Washer
33	2	013-5201-00	3/8" Flange Nut
34	2	018-5040-00	3/8" x 1 1/4" Hex Bolt
35	1	043-8929-00	Battery Hold Down
36	1	064-4001-00	Black Battery Cable - Diesel
37	1	064-4000-00	Red Battery Cable - Diesel
38	1	026-2006-00	2006 Seat Plate
39	2	019-6042-00	.360 ID Plastic Washer
40	6	013-8049-00	5/16-18 Nylon Flange Nut
41	2	018-8065-00	5/16" x 1" Carriage Bolt
42	1	071-4050-00	Grammer Suspension Seat
43	4	013-9002-00	5/16" Flange Nut
44	1	018-0011-00	1/4-20 x 2 Hex Bolt
45	2	013-8049-00	5/16-18 Nylon Flange Nut
46	2	013-9001-00	1/4-20 Hex Flange Nuts Zinc w/Serrations
47	1	034-1075-00	Torsion Spring for Seat latch
48	2	019-6042-00	.360 ID Plastic Washer
49	1	031-0200-00	Seat Latch Lever
50	1	018-0012-00	5/16-18 X 2 Hex C/S (GR.5) ZC
51	1	014-2009-00	Cooler Cover
52	4	030-7042-00	5/16 x 3/4 washer head type F screw
53	2	018-2018-00	1/2 x 3 1/2 Flange Bolt Grade 8
54	2	013-5300-00	1/2" Flange Nut
55	1	036-5300-00	Seat Switch Adapter

Diesel Pump Plate Assembly

DETAIL B

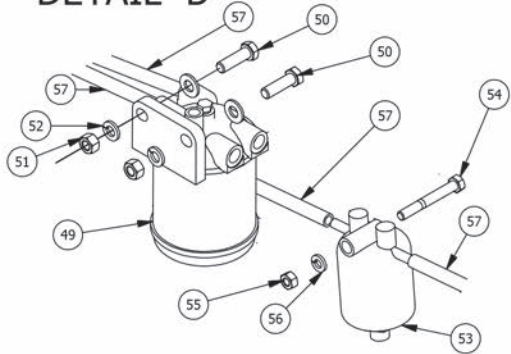

DETAIL C

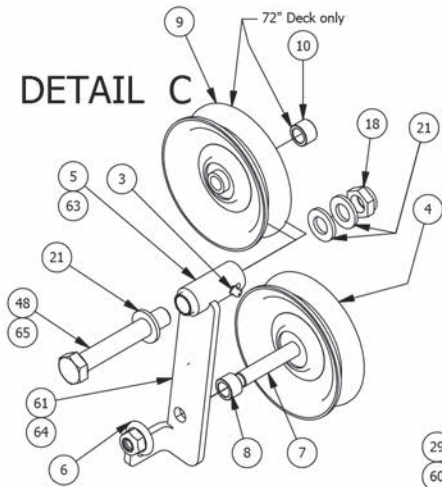

DETAIL A

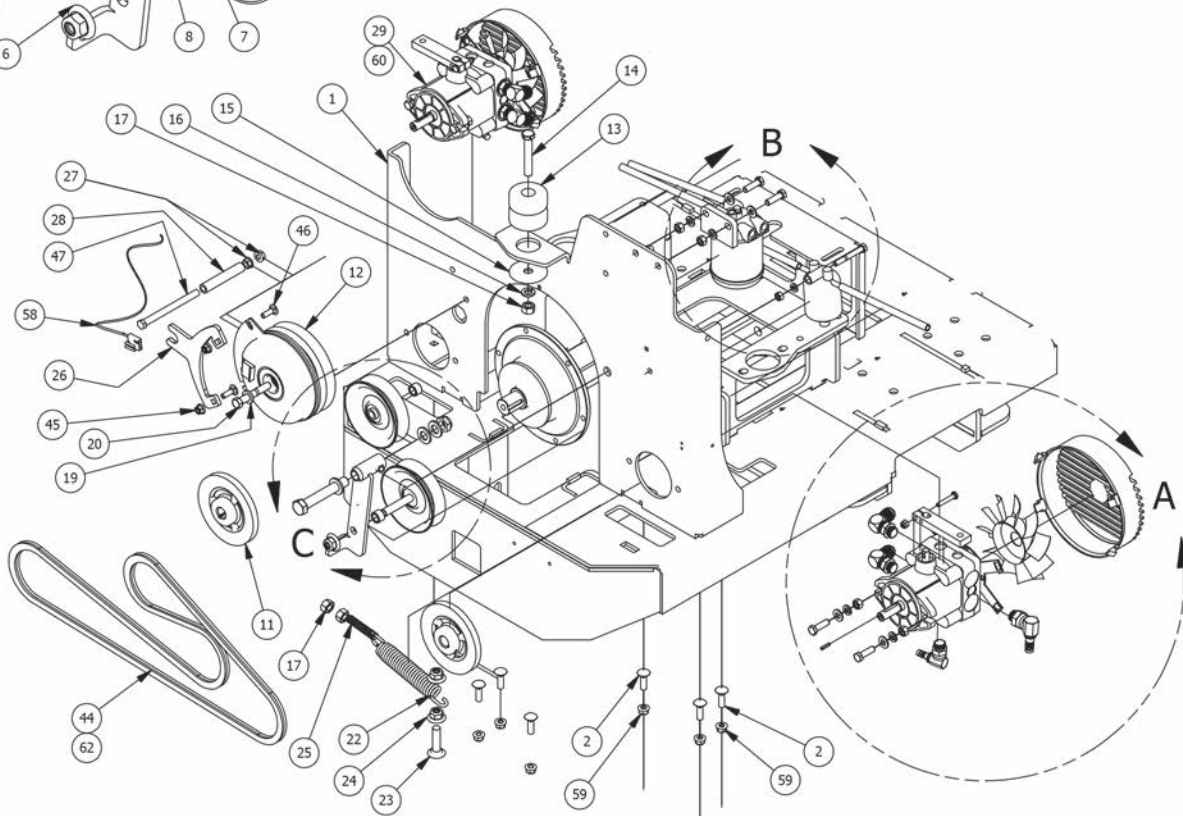
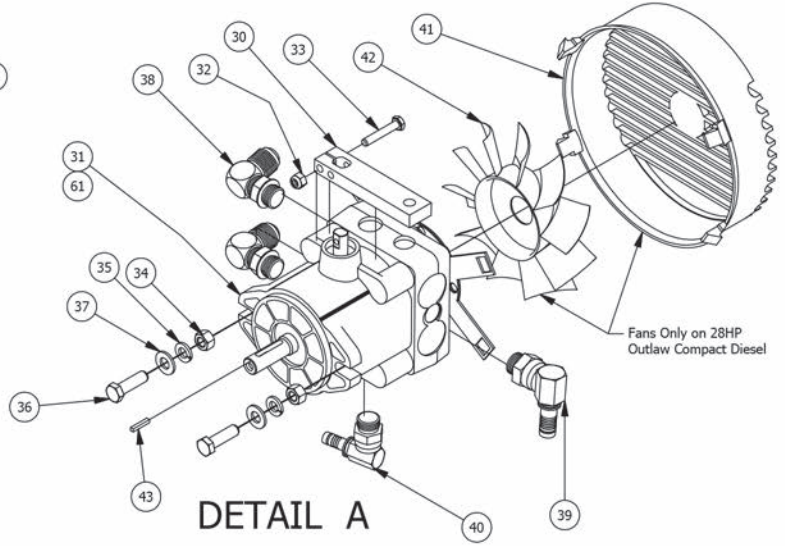



Diesel Pump Plate Assembly			
ITEM	QTY	PART NUMBER	DESCRIPTION
1	1	026-8030-00	Pump Plate Diesel
2	6	018-5043-00	3/8" x 1 1/4" Carriage Bolt
3	1	024-6034-00	1/4" Drive in Grease Fitting
4	1	033-6001-00	4 3/4" Idler Pulley
5	1	039-5950-00	Pump Idler Bracket only for 61" Deck
6	1	013-8050-00	1/2-13 Nylon Flange Nut-Orange
7	1	018-7016-00	1/2" x 3" Hex Bolt
8	1	025-7036-00	1/2 x 1/2 Spacer
9	1	033-4050-00	5" Idler Pulley only for 72" Deck Diesel
10	1	025-7020-00	5/8" x 1/" Collar Spacer only for 72" Deck Diesel
11	2	033-5011-00	5" Pump Pulley
12	1	070-5040-00	Clutch Assembly for Diesel
13	1	032-4000-00	Armor Plated Mount-Rear Mount
14	1	018-7016-00	1/2" x 3" Hex Bolt
15	1	032-4051-00	Snubbing Washer
16	1	019-5007-00	1/2" Lock Washer
17	3	013-7018-00	1/2" Hex Nut
18	1	013-5301-00	5/8" Nylock (1/2 Jam)
19	1	019-8053-00	7/16" Lock Washer
20	1	018-5401-00	7/16" x 2 3/4" Fine Thread Bolt
21	3	019-6017-00	.630 ID x 1.122 OD x .142 THK Plastic Washer
22	1	034-2009-00	Deck Idler Spring
23	1	018-1050-00	1/2 x 2" Carriage Bolt
24	2	013-8050-00	1/2-13 Nylon Flange Nut-Orange
25	1	018-2004-00	1/2-13 x 2-1/2 All Thd Stud
26	1	057-5910-00	Diesel PTO Engager Holder
27	2	013-5201-00	3/8" Flange Nut
28	1	051-8076-00	3/8 hose 4" long
29	1	050-5500-00	PR Pump W/Fan Left -28Hp Diesel
30	1	031-5923-00	Pump Arm
31	1	050-5501-00	PR Pump with Fan and Cover Right - 28Hp Diesel
32	1	013-8073-00	1/4" Nylock Nut
33	1	018-5005-00	1/4" x 1 1/2" Bolt
34	2	013-6014-00	3/8" Hex Nut
35	2	019-5037-00	3/8" Lock Washer
36	2	018-6012-00	3/8" x 1 1/2" Hex Bolt
37	2	019-5029-00	3/8" Flat Washer
38	2	024-2060-00	6801-LL-8-8 Fitting - Compact Diesel
39	1	024-5002-00	90 Degree Fitting 1/2" x 3/4" 4601-8-8
40	1	024-5206-00	90 Degree Fitting 3/8" X 9/16" - 4601-6-6
41	1	014-5500-00	Fan Guard 7" Fits Compact Diesel Only
42	1	015-9998-00	Hydro Fan Diesel 28hp Only
43	1	042-5012-00	5mm x 1.25" Key
44	1	041-5048-00	Pump Belt 28Hp Diesel
45	2	013-9002-00	5/16" Flange Nut
46	2	018-8065-00	5/16" x 1" Carriage Bolt
47	1	018-7055-00	3/8-16 x 5 Hex Bolt - Grade 5
48	1	018-5311-00	5/8" x 4" Hex Bolt 61" Deck only
49	1	063-2011-00	Fuel Filter
50	2	018-5040-00	3/8" x 1 1/4" Hex Bolt
51	2	013-6014-00	3/8" Hex Nut
52	2	019-5037-00	3/8" Lock Washer
53	1	015-0007-00	Caterpillar Fuel Bowl Kit
54	1	018-5344-00	5/16" x 2 1/2" Bolt
55	1	013-8043-00	5/16" Nut
56	1	019-8051-00	5/16" Lock Washer
57	4	051-8075-00	5/16" fuel line hose
58	1	070-2000-00	Clutch Pigtail
59	6	013-5202-00	3/8" Nylock Flange Nut
60	1	050-5308-00	Left Pump 16cc - AOS Diesel 35Hp Diesel
61	1	050-5407-00	Right Pump 16cc - AOS Diesel 35Hp Diesel
62	1	041-8411-00	Pump belt for 35HP Diesel
63	1	039-5945-00	Diesel Pump Idler only on 72" Deck
64	1	039-5945-98	Diesel Pump Idler Assembly Components 3,4,5,6,7,8,9,10 only for 72" Deck
65	1	018-6016-00	5/8 x 5 1/2 Bolt only for 72" Deck

Diesel Back Pump Cover

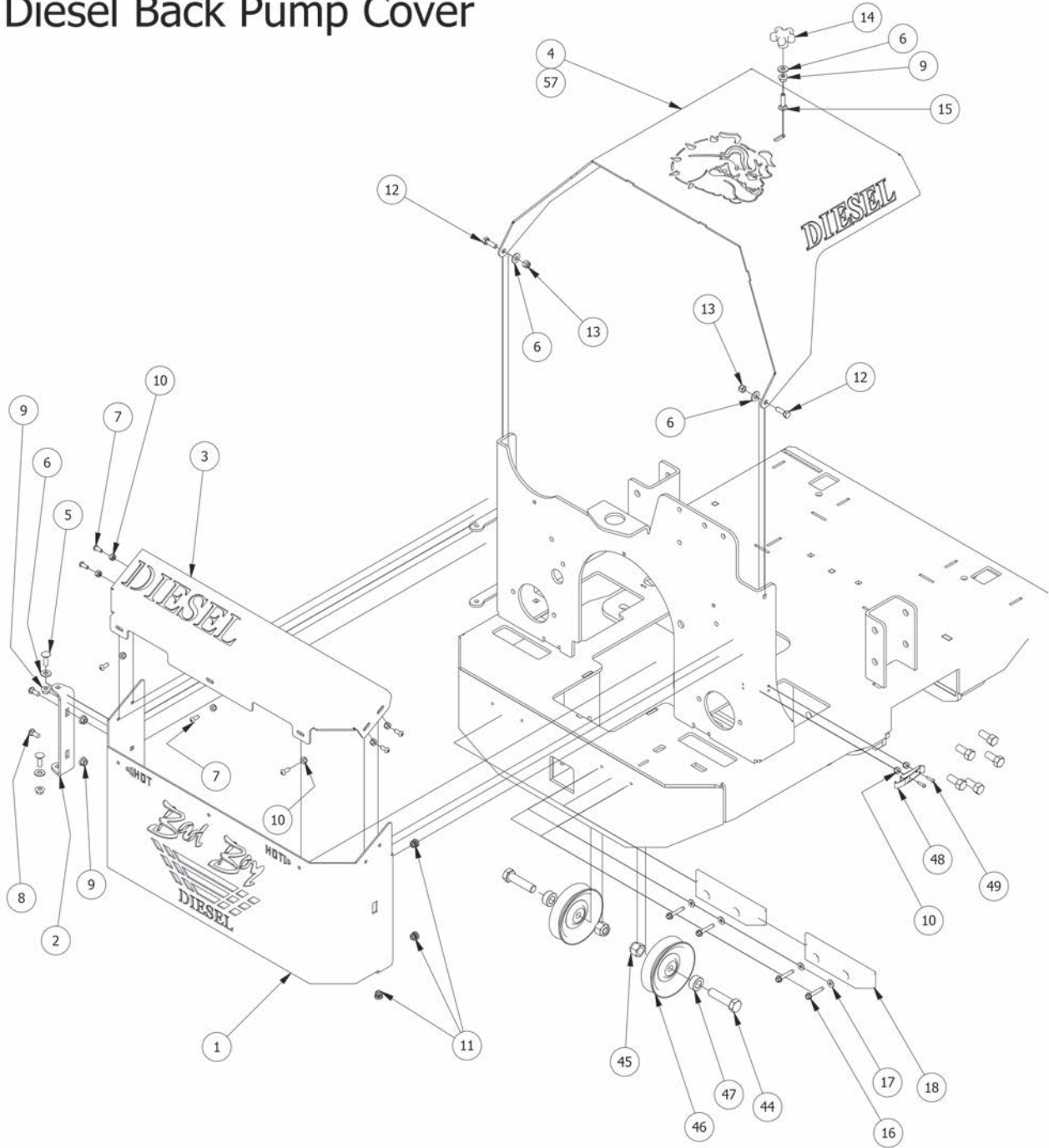

Diesel Suspension

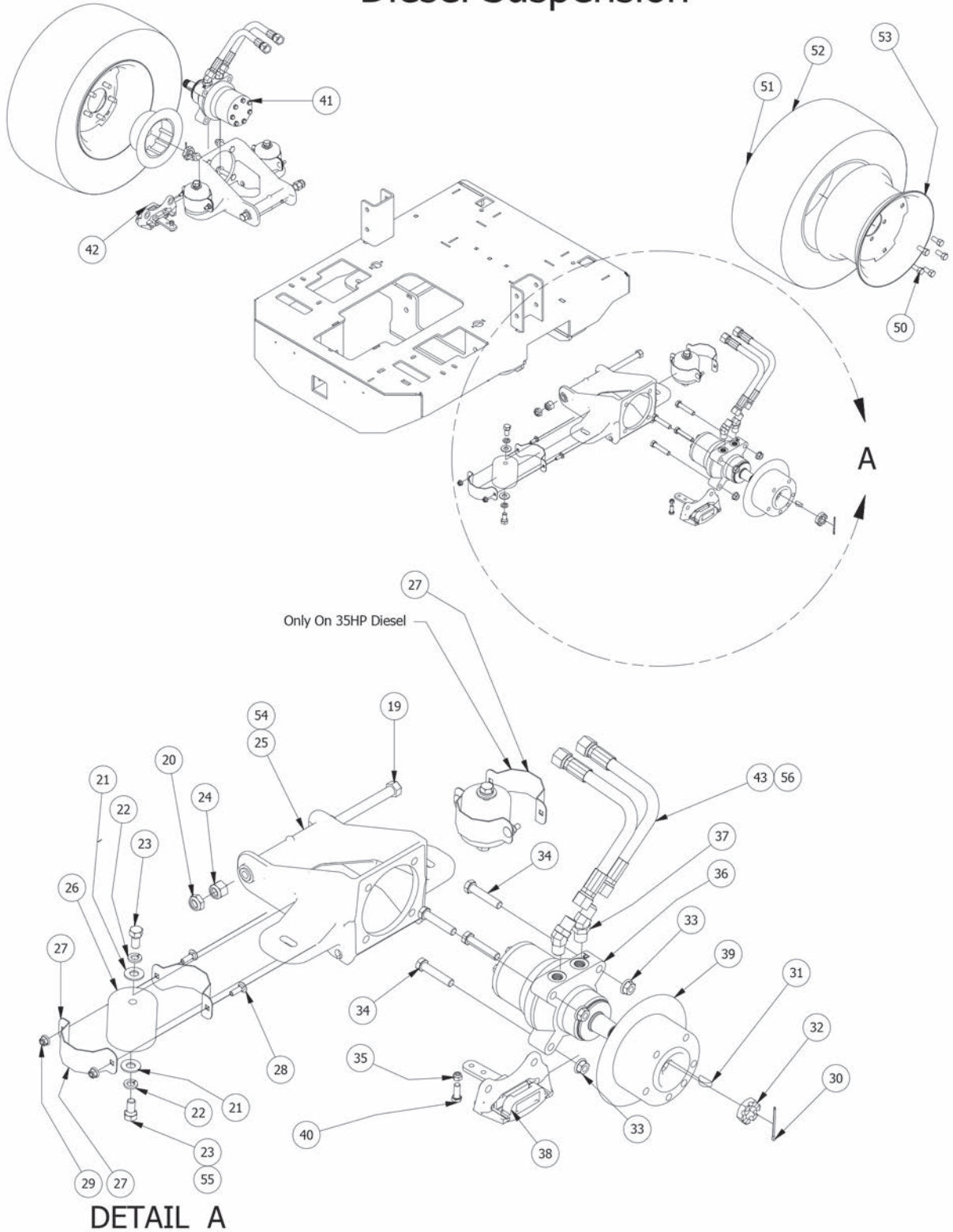

Diesel Suspension & Back Pump Cover Assemblies			
ITEM	QTY	PART NUMBER	DESCRIPTION
1	1	014-5920-00	Diesel Back Pump Cover 2008 Bottom
2	1	039-0070-00	Back Cover Hinge Bracket
3	1	014-5921-00	Diesel Back Pump Cover 2008 Top
4	1	059-8020-00	Diesel Hood 3 Cyl
5	2	018-8065-00	5/16" x 1" Carriage Bolt
6	5	019-6042-00	.360 ID Plastic Washer
7	7	018-8064-00	1/4" x 5/8" BS C/S 18-8 SS
8	2	018-8062-00	5/16-18x3/4 carriage bolt
9	5	013-9002-00	5/16" Flange Nut
10	9	013-8073-00	1/4 Nylock Nut
11	3	014-3010-00	5/8 Round Insert
12	2	018-2007-00	5/16" x 1" Bolt
13	2	013-8047-00	5/16-18 Nylock Insert Locknut
14	1	045-6043-00	5/16" Knob
15	1	018-4703-00	5/16" x 1 1/4" Carriage Bolt
16	4	030-7039-00	1/4" x 1 1/2" Self Tapping Screw
17	4	019-7040-00	1/4" Flat Washer
18	2	029-7038-00	8" Rubber Bumper
19	1	018-2051-00	5/8"x10" Hex Bolt (Grade8)
20	1	013-5301-00	5/8" Nylock (1/2 Jam)
21	4	019-5702-00	1/2" Washer (Grade 8)
22	4	019-5007-00	1/2" Lock Washer
23	4	018-2030-00	1/2" x 1" Hex Bolt
24	1	013-7021-00	5/8 Std NC Nylock Nut
25	1	070-8000-00	60 Suspension kit Wheel Motor
26	2	032-8999-00	Vibration Mount-Green Dot
27	4	072-1000-00	Isolator Band Clamp
28	4	018-8065-00	5/16" x 1" Carriage Bolt
29	4	013-8049-00	5/16" Nylon Flange Nut
30	1	020-7022-00	1/8x2-1/4 cotter pin Zinc
31	1	042-7041-00	Woodruff Key
32	1	013-7050-00	1" Castle Nut for Wheel Motor
33	4	013-5300-00	1/2" Flange Nut
34	4	018-6036-00	1/2" x 2 1/2" Hex Bolt
35	1	013-8047-00	5/16-18 Nylock Insert Locknut
36	1	015-4600-00	18cc Parker Wheel Motor- Right
37	2	024-2050-00	45 Degree Wheel Motor Fitting -6802-10-10
38	1	092-7000-00	XP/AOS Right Brake Caliper
39	1	092-5201-00	Brake Disk
40	1	018-6049-00	3/8" x 1" Hex Bolt
41	1	015-4601-00	18cc Parker Wheel Motor- Left
42	1	092-7001-00	XP/AOS Left Brake Caliper
43	4	051-2080-00	26" Hose Assembly with Adaptors
44	2	018-6059-00	5/8" x 2 1/2" Hex Bolt
45	2	013-7021-00	5/8 Std NC Nylock Nut
46	2	033-7025-00	5 V Idler Pulley - BCVI- 81
47	2	025-7020-00	5/8" x 1" Collar W/One Set Screw
48	1	052-3000-00	Steel Pump Cover Latch
49	2	018-5200-00	10-24 X 5/8 BS C/S 18-8 SS
50	10	018-7033-00	1/2-20 x 1-1/2 Lug Bolts Zinc
51	2	022-7031-00	26 x 12.00 - 12 Tire and Orange Wheel Assembly
52	1	022-7032-00	26 x 12.00 - 12 Tire
53	1	022-7034-00	12 x 10.5 Wheel AOS Rear
54	1	070-8001-00	72 Suspension Kit Wheel Motor
55	4	018-2080-00	1/2-13 1-1/4 Hex bolt Only On 60" Suspension Kit Wheel Motor
56	1	051-6085-00	26" Hose Only
57	1	059-8010-00	Diesel Hood 4cyl

Radiator Assembly

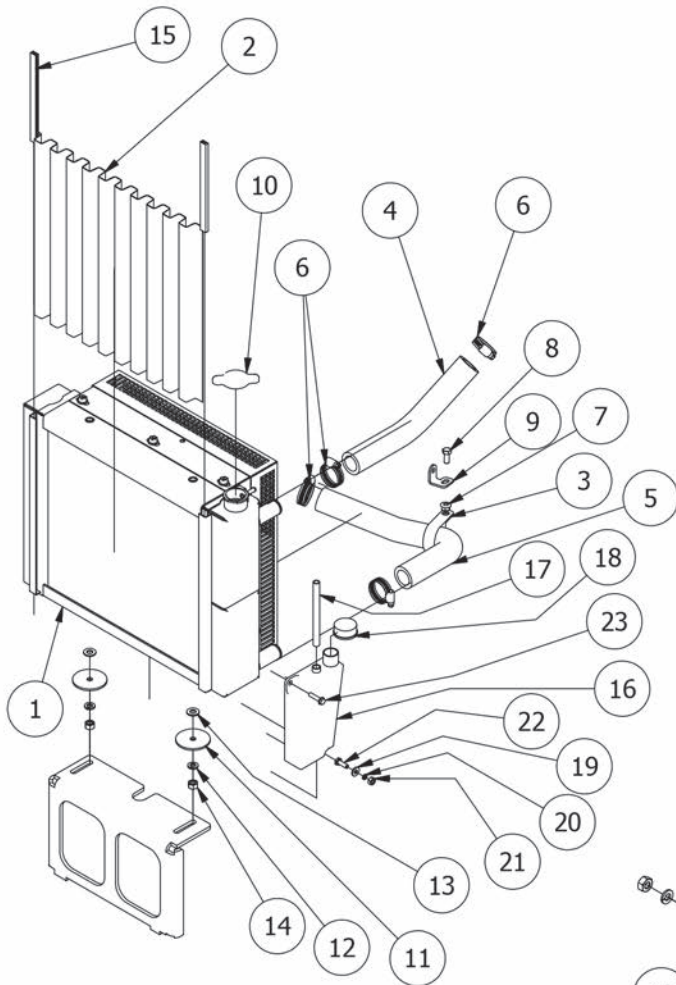

Diesel Hydraulic Cooler

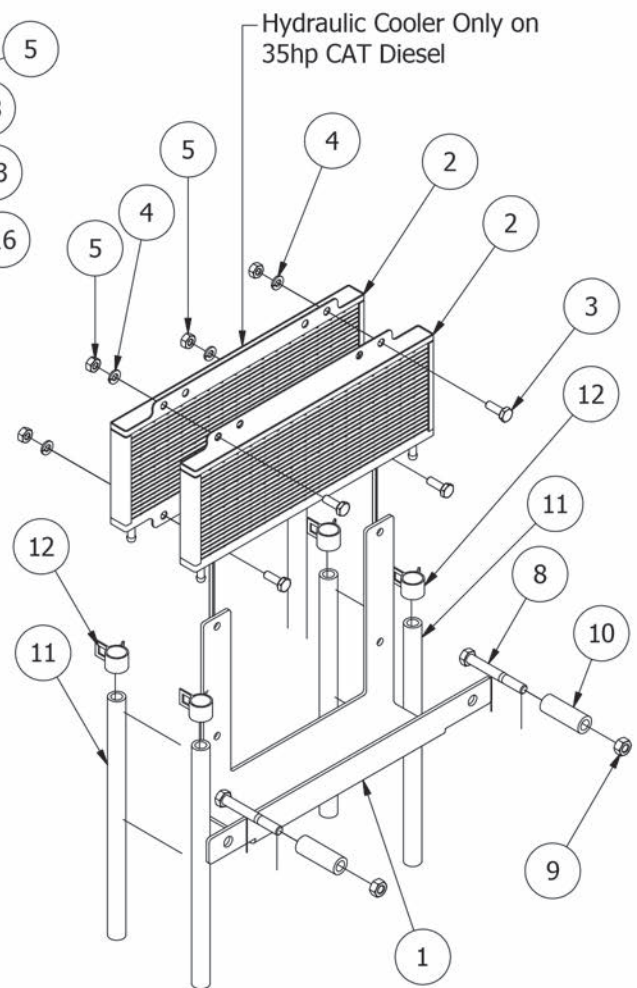

Radiator Assembly			
ITEM	QTY	PART NUMBER	DESCRIPTION
1	1	061-5000-00	Radiator- Diesel
2	1	094-5088-00	Radiator Screen-Diesel
3	1	072-8090-00	Diesel Clamp 1 3/4" Vinyl
4	1	051-3000-00	Top Radiator Hose for Diesel
5	1	051-3001-00	Bottom Radiator Hose for Diesel
6	4	072-2003-00	1 1/8" Hose Clamp
7	1	013-8049-00	5/16" Nylock Flange Nut
8	1	018-6083-00	5/16" x 3/4" Hex Bolt
9	1	039-1015-00	Diesel Radiator Hose Clamp Bracket
10	1	015-0104-00	Radiator cap
11	2	019-5050-00	3/8 x 2-1/4 OD Fibre Washer
12	2	019-5037-00	3/8" Lock Washer
13	2	019-5029-00	3/8" Flat Washer
14	2	013-6014-00	3/8" Hex Nut
15	2	084-4015-00	Rubber Trim
16	1	015-0111-00	overflow Reservoir- 28/35Hp Diesel
17	1	051-8069-00	5/16 Clear Hose
18	1	066-8075-00	Reservoir Tank Cap-Overflow
19	1	019-7040-00	1/4" Flat Washer
20	1	019-4008-00	1/4" Lock Washer
21	1	013-8039-00	1/4" Hex Nut
22	1	018-8052-00	1/4" x 3/4" Hex Bolt
23	1	030-7040-00	1/4 x 1 Hex Head tek screw

Diesel Hydraulic Cooler Only on 35Hhp Diesel			
ITEM	QTY	PART NUMBER	DESCRIPTION
1	1	057-5950-00	Cooler Holder
2	2	061-8012-00	Hydraulic Cooler
3	4	018-8052-00	1/4" x 3/4" Hex Bolt
4	4	019-4008-00	1/4" Lock Washer
5	4	013-8039-00	1/4" Hex Nut
8	2	018-5344-00	5/16" x 2 1/2" Bolt
9	2	013-8043-00	5/16" Nut
10	2	025-8000-00	.378 x .625x 1.750 Spacer Zinc
11	4	051-8063-00	3/8 clear hose price per foot
12	4	072-8065-00	3/8 hose clamp

Diesel Air filter Assembly

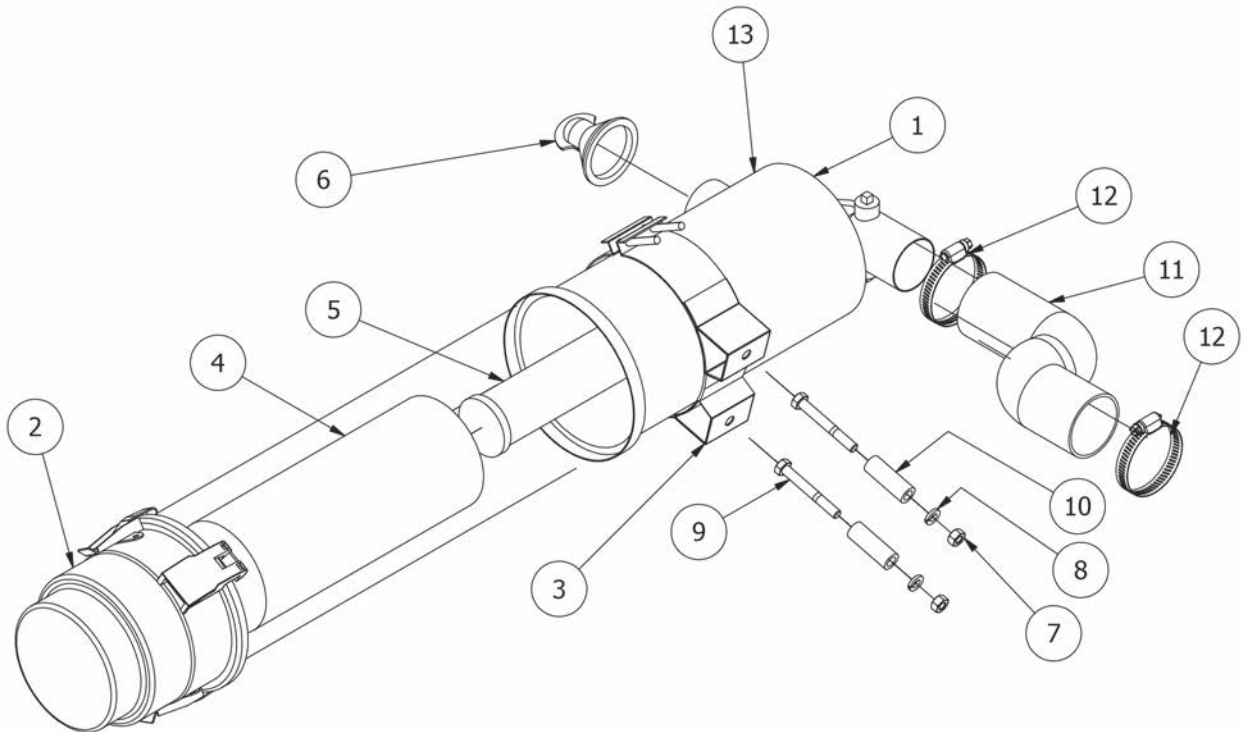

Diesel Air Filter Assembly			
ITEM	QTY	PART NUMBER	DESCRIPTION
1	1	088-1018-00	Canister for All Diesel Models
2	1	088-1017-00	Enginaire Air canister cap
3	1	088-1019-00	Mounting Bracket For Diesel Air Filter
4	1	063-2050-00	Diesel Air Filter- Outer
5	1	063-2060-00	Diesel Air Filter- Inner
6	1	088-1020-00	Debris Plug-Enginaire Filter
7	2	013-8043-00	5/16" Nut
8	2	019-8051-00	5/16" Lock Washer
9	2	018-5344-00	5/16" x 2 1/2" Bolt
10	2	025-8000-00	.378 x .625x 1.750 Spacer Zinc
11	1	051-3002-00	Air Intake Hose-Diesel Air Filter Canister
12	2	072-2002-00	2-1/2" Hose Clamp
13	1	088-1010-50	Enginaire Canister VLR-Complete Assembly

28Hp CAT Diesel Engine

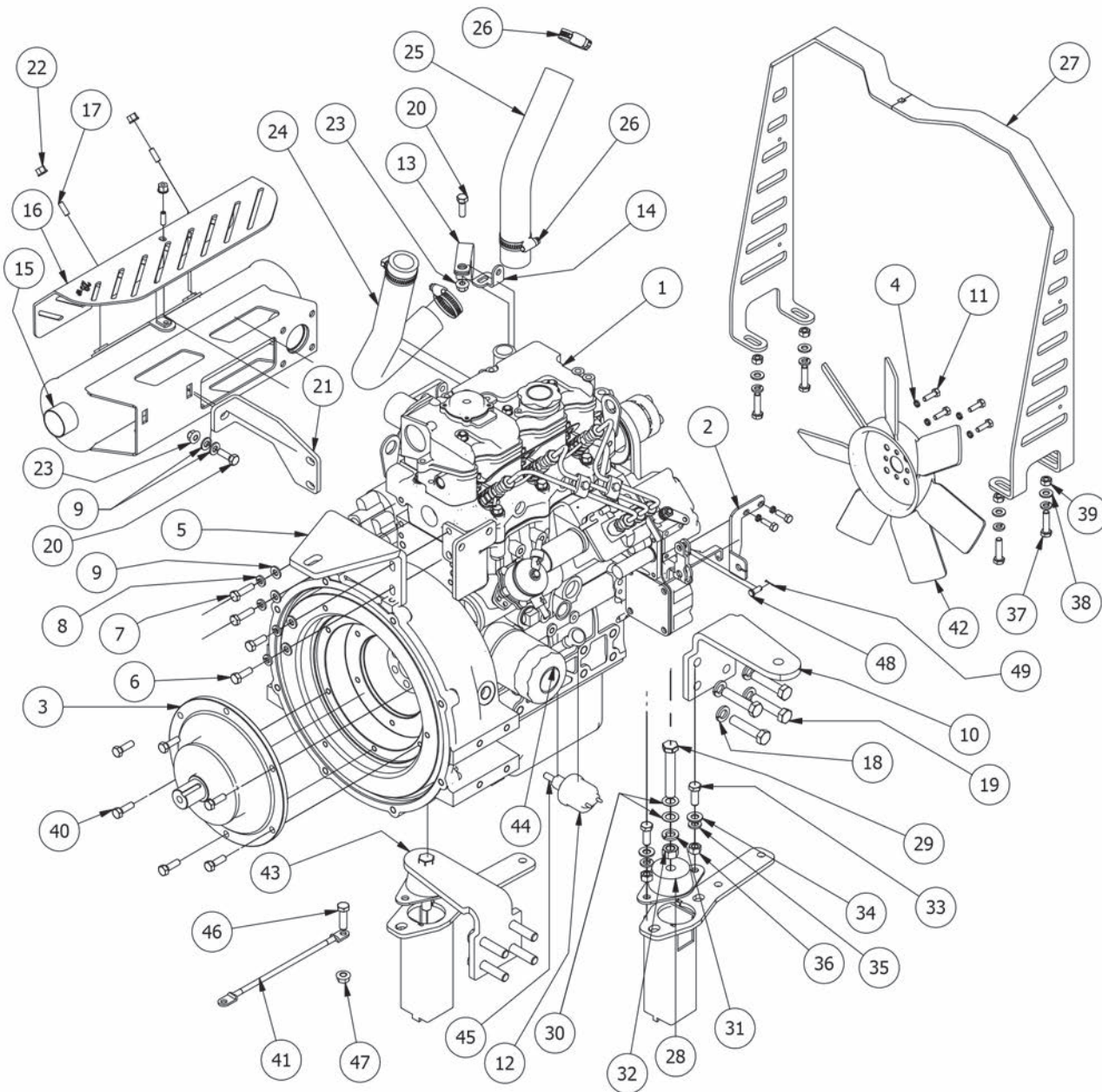



28hp CAT Diesel Engine			
ITEM	QTY	PART NUMBER	DESCRIPTION
1	1	015-0004-00	28hp CAT Diesel Engine
2	1	039-1010-00	Diesel Throttle Bracket (4 Tier)
3	1	017-3000-00	Stub Shaft
4	6	019-4008-00	1/4" Lock Washer
5	1	201-8005-00	Air Cleaner Support Diesel
6	2	018-2001-00	M8 x 1.25 x 25mm Hex Head Bolt
7	2	018-5320-00	M8 x 1.25 x 30mm Hex Head Bolt
8	10	019-8051-00	5/16" Lock Washer
9	6	019-8044-00	5/16" Flat Washer
10	1	201-8008-00	Diesel Motor Side Support Right
11	6	018-2000-00	6mm x 20mm Bolt
12	1	086-7004-00	Pressure sender-2012 Gauge and up
13	1	072-8090-00	Diesel Clamp 1 3/4" Vinyl
14	1	039-1015-00	Diesel Radiator Hose Clamp Bracket
15	1	015-0010-00	28/35hp Caterpillar Muffler
16	1	043-1010-00	Diesel Muffler Guard (28hp)
17	3	030-8000-00	1/4" x 3/4" Set Screw
18	8	019-5007-00	1/2" Lock Washer
19	8	018-6022-00	12mm Bolt- Diesel
20	8	018-2007-00	5/16" x 1" Bolt
21	1	203-8000-00	Muffler Brace Diesel
22	3	013-2050-00	1/4-20 Nylon Insert flange Nut
23	2	013-9002-00	5/16" Flange Nut
24	1	051-3001-00	Bottom Radiator Hose for Diesel
25	1	051-3000-00	Top Radiator Hose for Diesel
26	4	072-2003-00	1 1/8" Hose Clamp
27	1	201-8001-00	Hood Holder Diesel
28	2	032-4050-00	Rubber Isolator
29	2	018-7016-00	1/2" x 3" Hex Bolt
30	4	019-5010-00	1/2" Brass Washer
31	2	019-5007-00	1/2" Lock Washer
32	2	013-7018-00	1/2" Hex Nut
33	2	018-6049-00	3/8" x 1" Hex Bolt
34	3	019-5029-00	3/8" Flat Washer
35	3	019-5037-00	3/8" Lock Washer
36	3	013-6014-00	3/8" Hex Nut
37	4	018-5025-00	5/16" x 1 1/4" Hex Bolt
38	4	019-8044-00	5/16" Flat Washer
39	4	013-8043-00	5/16" Nut
40	6	018-0016-00	5/16-18 X 1 Button Head Bolt
41	1	086-0004-00	Starer To Chassis Cable - Diesel
42	1	015-6050-00	Engine Fan - Diesel
43	1	201-8009-00	Diesel Side Motor Mount Left
44	1	063-2010-00	CAT Oil Filter
45	1	019-2050-00	Brass Washer For Weld On Hinge
46	2	018-6012-00	3/8" x 1 1/2" Hex Bolt
47	1	013-5201-00	3/8" Flange Nut
48	1	044-2006-00	1/4-5/8 Clevis Pin
49	1	020-2000-00	3/32 X 1/2 Cotter-pin

35 HP CAT Diesel Engine

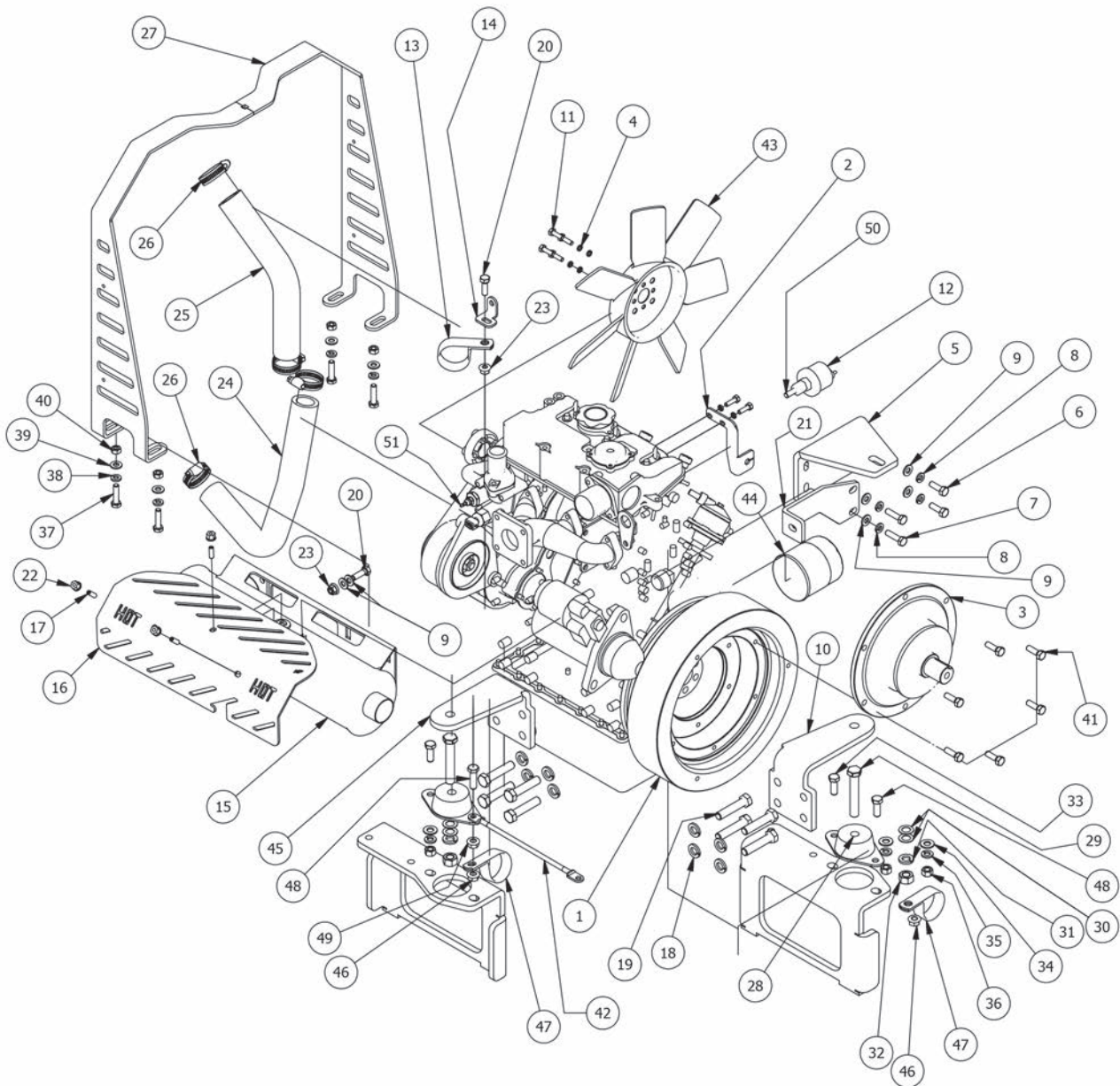



35HP Diesel Engine			
ITEM	QTY	PART NUMBER	DESCRIPTION
1	1	015-5600-00	35HP CAT Diesel Engine
2	1	039-1010-00	Diesel Throttle Bracket (4 Tier)
3	1	017-3000-00	Stub Shaft
4	6	019-4008-00	1/4" Lock Washer
5	1	201-8005-00	Air Cleaner Support Diesel
6	2	018-2001-00	M8 x 1.25 x 25mm Hex Head Bolt
7	2	018-5320-00	M8 x 1.25 x 30mm Hex Head Bolt
8	10	019-8051-00	5/16" Lock Washer
9	6	019-8044-00	5/16" Flat Washer
10	1	201-8008-00	Diesel Motor Side Support Right
11	6	018-2000-00	6mm x 20mm Bolt
12	1	086-7004-00	Pressure Sender-2012 Gauge and Up
13	1	072-8090-00	Diesel Clamp 1 3/4" Vinyl
14	1	039-1015-00	Diesel Radiator Hose Clamp Bracket
15	1	015-0010-00	28/35hp Caterpillar Muffler
16	1	043-1000-00	Diesel Muffler Guard (35Hp)
17	3	030-8000-00	1/4" x 3/4" Set Screw
18	8	019-5007-00	1/2" Lock Washer
19	8	018-6022-00	12mm Bolt- Diesel
20	8	018-2007-00	5/16" x 1" Bolt
21	1	203-8000-00	Muffler Brace Diesel
22	3	013-2050-00	1/4-20 Nylon Insert flange Nut
23	2	013-9002-00	5/16" Flange Nut
24	1	051-3001-00	Bottom Radiator Hose for Diesel
25	1	051-3000-00	Top Radiator Hose for Diesel
26	4	072-2003-00	1 1/8" Hose Clamp
27	1	201-8001-00	Hood Holder Diesel
28	2	032-4050-00	Rubber Isolator
29	2	018-7016-00	1/2" x 3" Hex Bolt
30	4	019-5010-00	1/2" Brass Washer
31	2	019-5007-00	1/2" Lock Washer
32	2	013-7018-00	1/2" Hex Nut
33	3	018-6049-00	3/8" x 1" Hex Bolt
34	3	019-5029-00	3/8" Flat Washer
35	3	019-5037-00	3/8" Lock Washer
36	3	013-6014-00	3/8" Hex Nut
37	4	018-5025-00	5/16" x 1 1/4" Hex Bolt
38	3	019-8051-00	5/16" Lock Washer
39	4	019-8044-00	5/16" Flat Washer
40	4	013-8043-00	5/16" Nut
41	6	018-0016-00	5/16-18 x 1 Button Head Bolt
42	1	086-0005-00	Starter to Chassis Cable - Diesel-35 Hp
43	1	015-6050-00	Engine Fan - Diesel
44	1	063-2010-00	CAT Oil Filter
45	1	201-8009-00	Diesel Side Motor Mount Left
46	1	013-9003-00	3/8 Nylock Jam Nut 1/2 Nut
47	2	072-8090-00	Diesel Clamp 1 3/4" Vinyl
48	2	018-6012-00	3/8" x 1 1/2" Hex Bolt
49	2	013-5201-00	3/8" Flange Nut
50	1	019-2050-00	Brass Washer for Weld-on Hinge
51	1	086-7003-00	Temperature Sender-2012 Gauge

Diesel 61" Deck

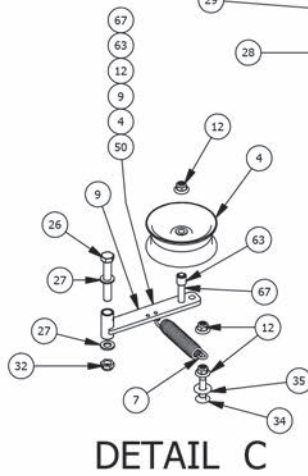
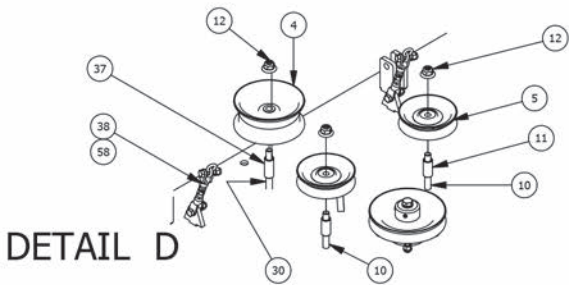
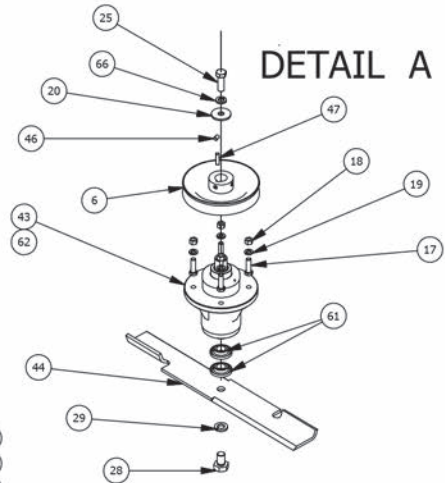
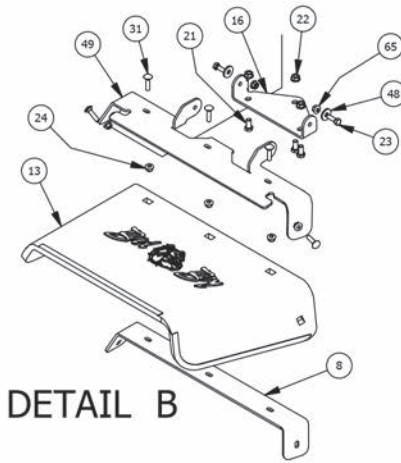
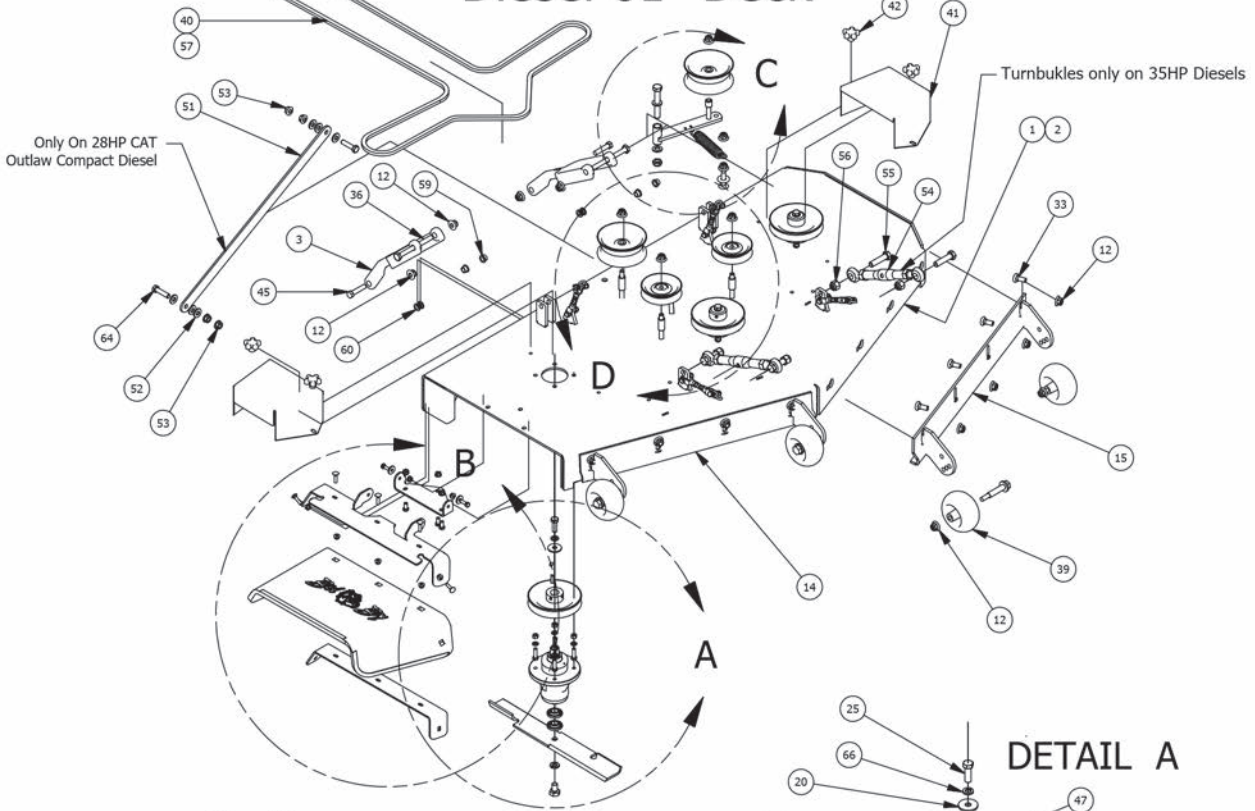



Diesel 61" Deck			
ITEM	QTY	PART NUMBER	DESCRIPTION
1	1	060-6100-00	61" Outlaw Deck Only 28HP Diesel
2	1	060-6130-00	61" AOS Deck Only 2012 35Hp Diesel
3	2	031-6010-00	Deck Arm Assembly
4	2	033-5000-00	5 3/4" Deck Idler Pulley
5	2	033-6001-00	4 3/4" Idler Pulley
6	3	033-6004-00	6 1/4" Drive Pulley
7	1	034-2009-00	2009 Deck/Pump Idler Spring
8	1	039-4863-00	60" Discharge Lower Bracket
9	1	039-6945-00	Deck Idler
10	2	018-2018-00	1/2 x 3 1/2 Flange Bolt Grade 8
11	2	025-5338-00	.502 ID X .75 OD X 1.500 Leng
12	24	013-8050-00	1/2-13 Nylon Insert Flange Nut
13	1	210-6005-00	Rubber Discharge Chute
14	1	060-6220-00	61 Outlaw Adjustable Deck Front (Left)
15	1	060-6210-00	61 Outlaw Adjustable Deck Front (Right)
16	1	206-6017-00	Discharge Chute Hanger (deck mounted)
17	12	018-5040-00	3/8" x 1 1/4" Hex Bolt
18	12	013-6014-00	3/8-16 Hex Nuts Zinc
19	12	019-5037-00	3/8 Lockwasher Zinc
20	3	019-6020-00	1/2 Belleville Washer
21	3	018-5250-00	3/8" x 3/4" Hex Bolt
22	3	013-5201-00	3/8" Flange Nut
23	2	018-2007-00	5/16" x 1" Bolt
24	5	013-9002-00	5/16" Flange Nut Zinc W/Serrations
25	3	018-6019-00	1/2"-20 x 1 1/2 - Grade 5 Fine Thread Bolt
26	1	018-5311-00	5/8" x 4" Hex Bolt
27	2	019-6017-00	.635 ID Plastic Washer
28	3	018-6020-00	5/8" x 1 1/2" Grade 8 Bolt
29	3	019-4807-00	5/8" Lock Washer
30	1	018-5019-00	1/2" x 4" Bolt (Grade 8)
31	5	018-4703-00	5/16" x 1 1/4" Carriage Bolt
32	1	013-5301-00	5/8-11 Nylon Insert Jam Half Nut
33	8	018-3003-00	1/2" x 1 1/4" Carriage Bolt
34	1	018-1050-00	1/2 x 2" Carriage Bolt
35	1	019-2040-00	1/2" Flat Washer
36	2	018-1090-00	1/2" x 5 1/2" Bolt
37	1	025-5339-00	1 3/4" Pulley Spacer
38	2	047-4000-00	4 - Link Adjustable Deck Hange 35HP Diesel
39	6	022-1000-00	Deck Wheel
40	1	041-0226-00	B226 Belt For 2012 (61" 28HP Compact Diesel Only)
41	2	014-6010-00	Pulley Cover
42	4	045-6043-00	5/16" Knob
43	3	037-8000-50	Double Bearing Spindle Only on 28hp Diesel
44	3	038-6080-00	61 Inch Fusion Blade
45	2	018-6037-00	1/2-13X 2-1/4 GR Hex Bolts
46	3	030-0050-00	5/16 Set Screw
47	3	042-6030-00	1/4" x 1" Key
48	2	019-6042-00	.360 ID Plastic Washer
49	1	039-4864-00	60" Discharge Chute Upper Hanger
50	1	039-6945-98	Deck Idler Assembly-parts of Assembly 4,9,12,63,67
51	1	028-6060-00	Panhard Linkage Bar
52	6	019-8054-00	.505 Nylon Spacer
53	4	013-5300-00	1/2" Flange Nut
54	2	048-6056-00	Turnbuckle (Top Link)
55	4	018-6059-00	5/8" x 2 1/2" Hex Bolt
56	4	013-7021-00	5/8 Std NC Nylock Nut
57	1	041-0236-00	B236 Belt - Diesel EZ Ride 35Hp (61" Diesel only)
58	4	047-6047-98	3 Link Adjustable Deck Hanger only on 28HP Diesel
59	4	032-5056-00	Flange Bushing For Deck Arm upper
60	4	032-5057-00	Flange for Lower Deck Arm
61	6	037-8001-00	Double Bearing For Spindle
62	1	037-8000-00	Double Bearing Spindle Only on 35hp Diesel
63	1	025-5203-00	3/4 OD x 1/2 ID x 3/4 Length
64	2	018-0022-00	1/2-13x2 Grade 8 Hex Bolt
65	2	013-8049-00	5/16" Nylon Flange Nut
66	3	019-5007-00	1/2" Lock Washer
67	1	018-7016-00	1/2-13 x GR 5 Hex Bolt Zinc

Diesel 72" Deck Assembly

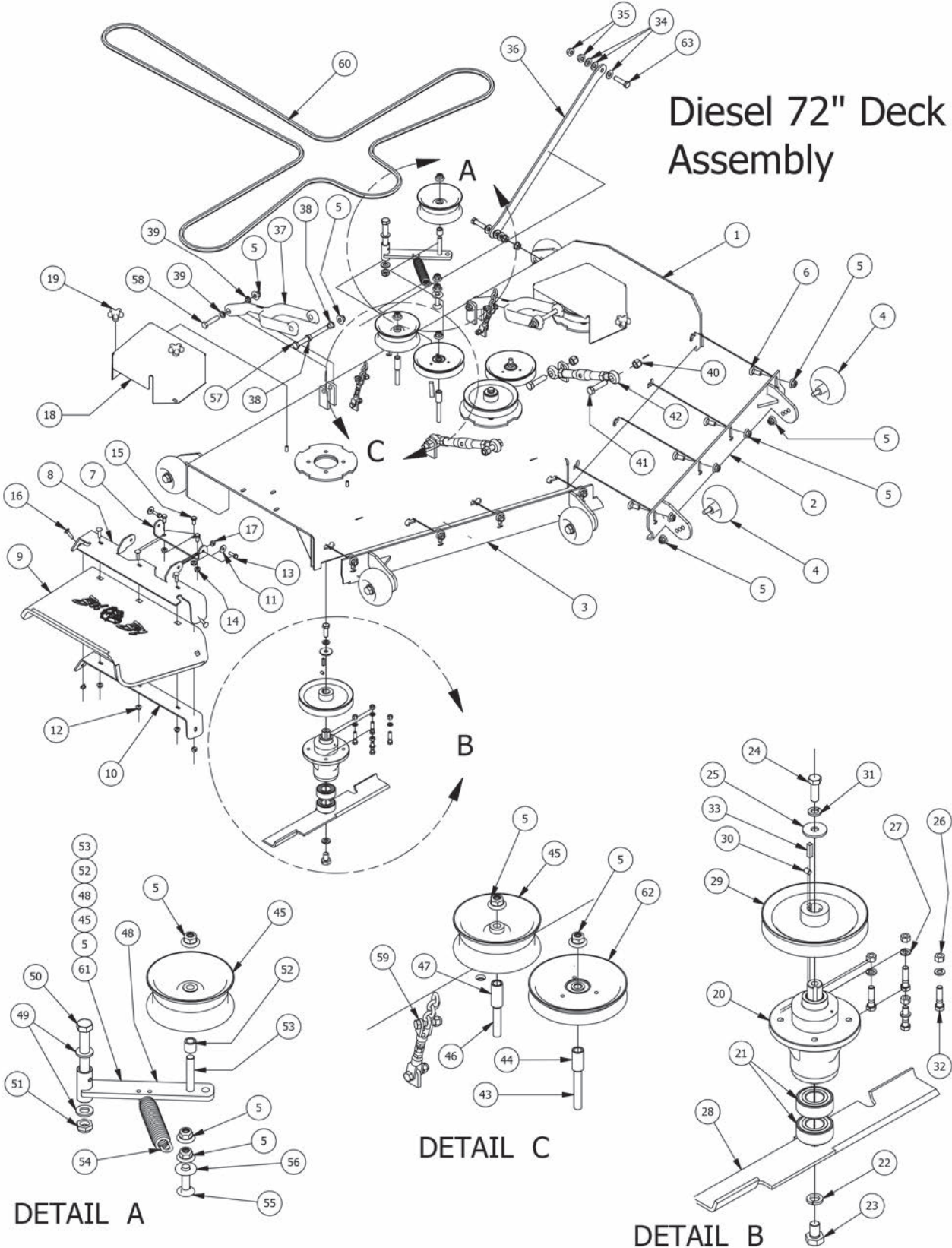



Parts List			
ITEM	QTY	PART NUMBER	DESCRIPTION
1	1	060-7201-00	72" Deck - Shell Only
2	1	060-7210-00	72" Deck Adjustable Front (Left)
3	1	060-7211-00	72" Deck Adjustable Front (Right)
4	6	022-1000-00	Deck Wheel
5	24	013-8050-00	1/2-13 Nylon Flange Nut-Orange
6	8	018-3003-00	1/2" x 1 1/4" Carriage Bolt
7	1	206-6017-00	Discharge Chute Hanger (deck mounted)
8	1	039-4864-00	60" Discharge Chute Upper Hanger
9	1	210-6005-00	Rubber Discharge Chute
10	1	039-4863-00	60" Discharge Lower Bracket
11	2	019-6042-00	.360 ID Plastic Washer
12	5	013-9002-00	5/16" Flange Nut Zinc W/Serrations
13	2	018-2007-00	5/16" x 1" Bolt
14	3	013-5201-00	3/8" Flange Nut
15	3	018-5250-00	3/8" x 3/4" Hex Bolt
16	5	018-4703-00	5/16" x 1 1/4" Carriage Bolt
17	2	013-8049-00	5/16" Nylon Flange Nut
18	2	014-7204-00	72 Spindle Cover
19	4	045-6043-00	5/16" Knob
20	3	037-8000-00	Double Bearing Spindle
21	2	037-8001-00	Double Bearing for spindle
22	1	019-4807-00	5/8" Lock Washer
23	1	018-6020-00	5/8" x 1 1/2" Grade 8 Bolt
24	1	018-6019-00	1/2"-20 x 1 1/2 - Grade 5 Fine Thread Bolt
25	1	019-6020-00	1/2 Belleville Washer
26	4	013-6014-00	3/8-16 Hex Nuts Zinc
27	4	019-5037-00	3/8 Lockwasher Zinc
28	1	038-7230-00	72" High Lift Fusion Blade
29	1	033-7203-00	7" Deck Pulley
30	1	030-0050-00	5/16 Set Screw
31	1	019-5007-00	1/2" Lock Washer
32	4	018-6012-00	3/8" x 1 1/2" Hex Bolt
33	1	042-6030-00	1/4" x 1" Key
34	6	019-8054-00	.505 Nylon Spacer
35	4	013-5300-00	1/2" Flange Nut
36	1	028-6070-00	72" Diesel Deck Panhard Linkage Bar
37	2	031-6010-00	Deck Arm Assembly
38	4	032-5056-00	Flange Bushing For Deck Arm upper
39	4	032-5057-00	Flange for Lower Deck Arm
40	4	013-7021-00	5/8 Std NC Nylock Nut
41	4	018-6059-00	5/8" x 2 1/2" Hex Bolt
42	2	048-6056-00	Turnbuckle (Top Link)
43	2	018-2018-00	1/2 x 3 1/2 Flange Bolt Grade 8
44	2	025-5338-00	.502 ID X .75 OD X 1.500 Leng
45	2	033-5000-00	5 3/4" Deck Idler Pulley
46	1	018-5019-00	1/2" x 4" Bolt (Grade 8)
47	1	025-5339-00	1 3/4" Pulley Spacer
48	1	039-6945-00	Deck Idler
49	2	019-6017-00	.635 ID Plastic Washer
50	1	018-5311-00	5/8" x 4" Hex Bolt
51	1	013-5301-00	5/8-11 Nylon Insert Jam Half Nut
52	1	025-5203-00	3/4 OD x 1/2 ID x 3/4 Length
53	1	018-7016-00	1/2-13 x GR 5 Hex Bolt Zinc
54	1	034-2009-00	2009 Deck/Pump Idler Spring
55	1	018-1050-00	1/2 x 2" Carriage Bolt
56	1	019-2040-00	1/2" Flat Washer
57	2	018-1090-00	1/2" x 5 1/2" Bolt
58	2	018-6037-00	1/2-13X 2-1/4 GR Hex Bolts
59	2	047-5000-00	5- Link Adjustable Deck Hange
60	1	041-2525-00	B252-50 Fits 72 Diesel
61	1	039-6945-98	Deck Idler Assy Componets 5,45,48,52,53
62	2	033-7201-00	5-3/4 Idler Pulley 72" Decks only
63	2	018-0022-00	1/2-13x2 Grade 8 Hex Bolt

037-8000-50 & 8000-00 Double Bearing Spindle

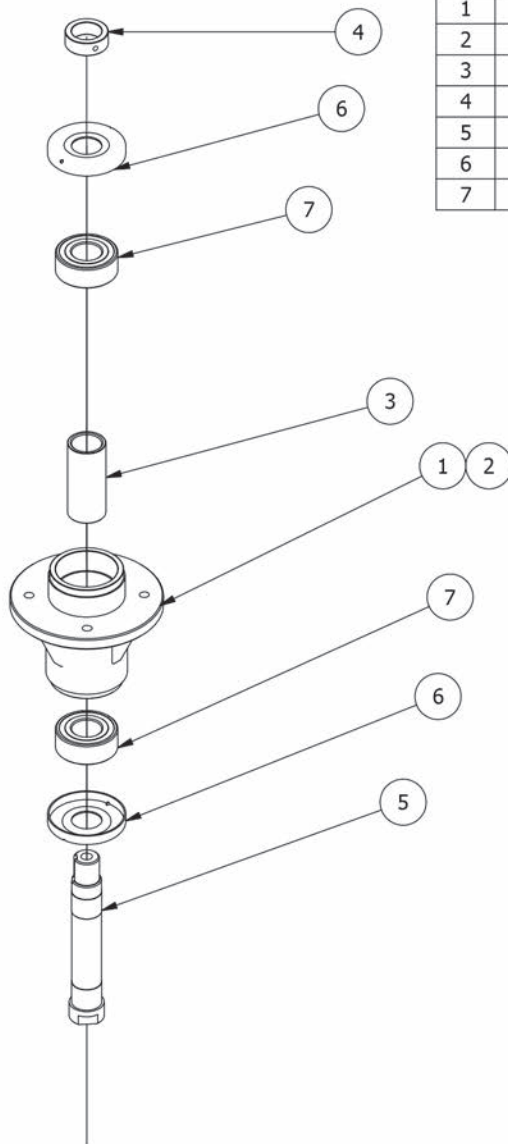

037-8000-50 & 8000-00			
ITEM	QTY	PART NUMBER	DESCRIPTION
1	1	037-8005-50	Aluminum Spindle Housing
2	1	037-8005-00	Spindle Housing -Dble Brg
3	1	037-8003-00	Tube Spacer Double Bearing Spindle
4	1	037-9050-00	Collar Spacer - Top of Spindle
5	1	037-6026-00	Short Spindle Shaft w/Locking
6	2	037-8002-00	Dust Cover
7	2	037-8001-00	Double Bearing for spindle



091-2061-00
Diesel Control Panel Decal
Left



091-2062-00
Diesel Instrument Panel Decal
Right



091-2064-00
28hp Decal
Hood Diesel



091-2065-00
35hp Decal-Diesel Models



091-1101-00
Brake



091-1102-00
Speed control
Left



091-1103-00
Speed Control
Right



091-1104-00
Throttle



019-2063-00
Preheat Decal



091-5402-00
Cat Powered Decal



091-2001-00
Bad Boy Oval Logo Decal



091-0902-00
Logo Decal-Floorboard



091-0919-00
Armortek Decal



091-0917-00
61" Decal

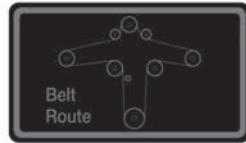

091-3309-00
Deck Belt Route Decal



091-3300-00
Caution Decal-Front Grill



091-3015-00
hydraulic tank

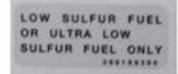

091-2050-00
Low Sulfur Decal



091-0918-00
72" Decal



091-1105-00
Outlaw Deck Height Decal

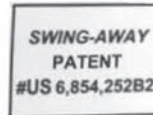

091-3060-00
Swing-Away Patent Decal



091-3012-00
Danger Decal- Spindle/Discharge

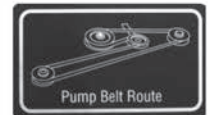

091-3017-00
Pump Belt Route Decal

**2014 LIMITED WARRANTY
FOR
BAD BOY COMMERCIAL MOWER
(CZT, STAND ON, DIESEL, OUTLAW, OUTLAW EXTREME, and OUTLAWXP)**

1. WHAT THIS WARRANTY COVERS, AND FOR HOW LONG:

Bad Boy, Inc. will, at its option, repair or replace, without charge, any part covered by the warranty which is found to be defective in material and/or workmanship within two (2) years* after date of sale to the original retail purchaser unless the product is used for rental purposes, in which case this warranty is limited to ninety (90) days.

The leading edge of the deck shell will be warranted for the entire lifetime of the machine to the original purchaser against defects in materials and workmanship. Labor required to repair or replace the leading edge of the deck shell will be covered by Bad Boy Inc. for two years and at the unit owner's expense during the balance of the lifetime of the machine.

The Bad Boy ZT Series, featuring the **Integrated Zero Turn Transaxle**, used commercially will carry the shorter of a one year or 200 hour warranty, **parts only**. Labor on a Bad Boy ZT Series machine used commercially will not be covered by Bad Boy Inc. and will be the unit owner's responsibility.

Belts are warranted for a period of ninety (90) days against materials or workmanship defects.

Seats are warranted for a period of (6) months against material or workmanship defects.

At Bad Boy, Inc.'s request, customer will make the defective part available for inspection by Bad Boy, Inc. and/or return the defective part to Bad Boy, Inc., **transportation charges prepaid**.

2. WHAT THIS WARRANTY DOES NOT COVER:

A. This warranty does not cover defects caused by depreciation or damage caused by normal wear, accidents, improper maintenance, improper use or abuse of the product, alterations, or failure to follow the instruction contained in the Owner's Manual for operation and maintenance.

B. The customer shall pay any charges for making service calls and/or for transporting the mower to and from the place where the inspection and/or warranty work is performed.

Bad Boy Inc. will not be responsible for the pickup and delivery of a machine for warranty purposes.

C. **Engines** are warranted separately by their respective manufacturer. The available warranties covering this item are furnished with each mower. Bad Boy, Inc. does not assume any warranty obligation, liability or modification for this item, which is covered exclusively by the stated warranty of the respective manufacturers.

D. **Tires, blades, deck anti-scalping wheels** are considered to be consumable wear items and are therefore **not warranted**.

E. **Batteries** are warranted for six months (**free replacement**) from the retail purchase date against materials or workmanship defects. **The battery warranty must be obtained through the battery manufacturer.**

3. HOW TO OBTAIN SERVICE UNDER THIS WARRANTY:

A. Warranty service can be arranged by contacting the dealer where you purchased the mower or by contacting Bad Boy, Inc. Proof of the date of purchase may be required to verify warranty coverage.

B. **Warranty claims will not be reviewed or paid unless the warranty registration card is received by Bad Boy, Inc. within 30 days of the retail purchase date.**

C. Warranty claims requiring parts returned will be settled upon return of parts to Bad Boy for inspection.

4. WARRANTY LIMITATION:

A. **THERE IS NO OTHER EXPRESS WARRANTY. ANY WARRANTY THAT MAY BE IMPLIED FROM THIS PURCHASE INCLUDING MERCHANTABILITY AND FITNESS FOR A PARTICULAR PURPOSE IS HEREBY LIMITED TO THE DURATION OF THIS WARRANTY AND TO THE EXTENT PERMITTED BY LAW ANY AND ALL IMPLIED WARRANTIES ARE EXCLUDED.** Some states do not allow limitations on how long an implied warranty lasts, so the above limitations may not apply to you.

B. **BAD BOY, INC. WILL NOT BE LIABLE FOR ANY INCIDENTAL, CONSEQUENTIAL, OR SPECIAL DAMAGES AND/OR EXPENSES IN CONNECTION WITH THE PURCHASE OR USE OF THE MOWER.** Some states do not allow the exclusion or limitation of incidental or consequential damages, so the above limitation(s) or exclusion(s) may not apply to you.

C. Only the warranty expressed in this limited warranty shall apply and no dealer, distributor, or individual is authorized to amend, modify, or extend this warranty in any way. Accordingly, additional statements such as dealer advertising or presentations, whether oral or written, do not constitute warranties by Bad boy, Inc., and should not be relied on.

D. This warranty extends only to turf equipment operated under normal conditions and properly serviced and maintained. The warranty expressly does not cover (i) any defects, damage or deterioration due to normal use, wear and tear, or exposure; (ii) normal maintenance services such as oil change, cleaning, lubrication, adjustment; (iii) replacement of services, items, such as oil, lubricants, spark plugs, belts, rubber hoses or other items subject to normal service replacement; (iv) damage or defects arising out of or relating to misuse, neglect, alteration, negligence or accident; (v) repair or replacement arising from operation of or use of the turf equipment which is not in accordance with operating instructions as specified in the operator's manual or other operational instructions provided by Bad Boy Inc.; (vi) repair or replacement arising as a result of any operation from turf equipment that has been altered or modified so as to, indetermination of Bad Boy, Inc., adversely affect the operation, performance or durability of the equipment or that has altered, modified or affected the turf equipment so as to change the intended use of the product; (vii) repair or replacement necessitated by use of parts, accessories or supplies, including gasoline, oil or lubricants, incompatible with the turf equipment or other than as recommended in the operator's manual or other operational instructions provided by Bad Boy, Inc.; (viii) repairs or replacements resulting from parts or accessories which have adversely affected the operation, performance or durability of the turf equipment; or (ix) damage or defects due to or arising out of repair of turf equipment by person or persons other than an authorized Bad Boy, Inc., service dealer or the installation of parts other than genuine Bad Boy, Inc., recommended parts.

As a condition to this warranty, customer shall have read the operator's manual and shall have returned to Bad Boy, Inc., within the prescribed time, the enclosed warranty registration card.

E. This warranty gives you specific legal rights, and you may also have other rights, which vary from state to state.



Bad Boy, Inc.
102 Industrial Drive
Batesville, AR 72501
1.866.622.3269
www.badboymowers.com

Technical Support:

James Russell..... james.russell@badboymowers.com

Warranty:

Jack Vaughn jack.vaughn@badboymowers.com

Parts:

Tim Tosh..... tim.tosh@badboymowers.com

Robert Patterson robert.patterson@badboymowers.com

Cut and Mail or Fill Out Online under 'Owners' at www.badboymowers.com

WARRANTY REGISTRATION

Full Name _____

Address _____

City _____

State _____ Zip _____

SERIAL #

Purchase Date _____ Telephone _____

Purchased From _____

"I certify that I have been properly instructed on operating this machine."



For additional information, please see us at
www.badboymowers.com

Bad Boy, Inc.
102 Industrial Drive
Batesville, Arkansas 72501
(870) 698-0090

Cut and Mail or Fill Out Online under 'Owners' at www.badboymowers.com

*Place Stamp
Here*

*POST OFFICE
WILL NOT DELIVER
WITHOUT POSTAGE*



BAD BOY MOWERS

102 Industrial Drive
Batesville, AR 72501