



Diesel AOS & Compact



ZERO-TURN MOWER OWNER'S, SERVICE & PARTS MANUAL

For additional information, please see us at
www.badboymowers.com

Bad Boy, Inc.
102 Industrial Drive
Batesville, Arkansas 72501
(870) 698-0090

TABLE OF CONTENTS

Basic Information.....	Section 1 (pages 4–5)
Bad Boy Safety Guidelines	Section 2 (pages 5–6)
Operation	Section 3 (pages 6–7)
Maintenance	Section 4 (page 7)
Storage and Transportation	Section 5 (page 8)
Troubleshooting and FAQ.....	Section 6 (pages 8–9)
Controls	Section 7 (page 9)
Moving Inoperable Mower	Section 8 (page 10)
Instrumentation	Section 9 (page 10)
Mower Blade Maintenance.....	Section 10 (page 11)
Greasing Bearings.....	Section 11 (pages 11)
How to choose the right blade	Page 12
Mowing Tips	Page 21

SERVICE SECTION BEGINS ON PAGE 13
PARTS SECTION BEGINS ON PAGE 22
LIMITED WARRANTY PAGE 50



This manual applies to the following equipment:

Bad Boy Diesel Series

Diesel Compact 6000 60" 28hp 3-Cylinder Diesel

Diesel 6000 60" 35hp 4-Cylinder Diesel

Diesel 7200 72" 35hp 4-Cylinder Diesel

COMMONLY USED ITEMS AND PART NUMBERS

72" Blade	Hi-Lift Fusion 038-7230-00	Gator Blade 038-5400-00	Wave Blade 038-7215-00
60" Blade	Hi-Lift Fusion 038-6060-00	Gator Blade 038-6003-00	Wave Blade 038-6015-00
Deck Belt	72" 041-2525-00	60" 041-0236-000	
Pump Belt	041-8411-00		
CATERPILLAR Oil Filter	CAT 28hp 063-2010-00		
Air Filter	CAT 28hp Inner 063-2060-00	CAT 28hp Outer 063-2050-00	
CATERPILLAR Oil Filter	CAT 35hp 063-2010-00		
Air Filter	CAT 35hp Inner 063-2060-00	CAT 28hp Outer 063-2050-00	
Motor Oil	10w30 (4 quarts)		
Hydro Oil	20w50 (8 quarts)		

SECTION 1: BASIC INFORMATION

Congratulations on the purchase of your new Bad Boy Mower! The purpose of this manual is to assist operators in maintaining and operating their machine. The information and instructions in this manual can help you attain years of performance from your new Bad Boy. Also, check out our website to learn more about the Bad Boy family.

- 1.1 All Bad Boy engines use 10W30 engine oil. Conventional or Synthetic may be used.
- 1.2 All Bad Boy hydraulic systems use 20W50 engine oil. Conventional or Synthetic may be used.
- 1.3 All Bad Boy Mowers use hi-temp multi-purpose grease. NLGI No. 2 for the grease fittings.
- 1.4 Diesel models have 12 psi in both front and rear tires.

Warranty Registration

The Warranty Registration form must be completed and signed to validate your warranty. As the new equipment owner, you are expected to see that the form is completed and forwarded to Bad Boy, Inc., at time of delivery. Warranty is non transferable.

Model/Serial Number

Your Diesel model serial numbers are found on the SIN plate underneath seat. The serial numbers are necessary on the warranty registration form. Also, these numbers can assist you in the ordering of new parts when replacements become necessary.

Parts/Service

Only Bad Boy replacement parts are to be used on your mower.

Replacement parts are available through your local Bad Boy Mower Dealer. Remember to always provide the following information when ordering parts:

1. Correct part number
2. Correct serial number

All warranty repair and service must be handled through your authorized Bad Boy Mowers dealer.

To locate the nearest dealer, go to our website and click on Locate a Dealer.



SECTION 2: MOWER SAFETY GUIDELINES

Never allow untrained people to operate this machine. It is the owner's responsibility to get training and see to it that anyone who has permission to use your machine receives the proper training.

Do not mow around people. The factory discharge chute is designed to deflect debris downward, but it could be possible for debris to be thrown in a way that can cause damage to people or property.

Seek additional training when possible to learn more about safety techniques and practices.

SAFETY PRECAUTIONS

- 2.2 Always remain seated while operating machine.
- 2.3 Always maintain a safe distance from people and pets while mowing.
- 2.4 Always disengage blades, place steering controls in neutral, engage parking brake, and remove ignition key when leaving operators seat.
- 2.5 Always operate machine in daylight or with adequate working lights.
- 2.6 Be alert of surroundings. Watch for rocks, stumps, and mounds or depressions while mowing.
- 2.7 Always wear eye protection while mowing and servicing.
- 2.8 Always wear ear protection, such as earplugs, while mowing.
- 2.9 If you strike something with the mower turn the blades and mower off, engage the parking brake, and inspect the machine for damage before resuming.
- 2.10 Be aware of low hanging limbs or objects that could potentially be hazardous while mowing.
- 2.11 Never operate a poorly maintained machine.
- 2.12 Never carry passengers.
- 2.13 Always buckle seat belt, if provided one.
- 2.14 Never attempt high speed maneuvering, especially around people or property.
- 2.15 Never put hands or feet under the machine while ignition is on.
- 2.16 Never refuel machine when engine is running.
- 2.17 Never leave key in ignition, especially around children.
- 2.18 Never run engine in enclosed area.
- 2.19 Do not touch hot parts of machine.
- 2.20 Do not remove deck wheels.
- 2.21 Conditions that can affect traction resulting in the loss of control of machine: Wet terrain, Hills or extreme angles, Depressions in the ground, Mounds of dirt, Extremely dry grass, Soil type (gravel, sand, clay), Tire pressure
- 2.22 Be aware of what is located at the bottom of slopes. For example, Rocks, Water, Cliffs, Roads and Highways

2.23 Safety warning decals are located on the mower and should always be observed and followed.

- 2.24 Never operate the mower with the discharge chute open.
- 2.25 Prevent Fires—Remove grass and debris from engine compartment and muffler area, before and after operating machine, especially after mowing or mulching in dry conditions.
- 2.26 Do not store machine near open flame or source of ignition, such as a water heater or furnace.
- 2.27 Do not attempt to mount a tire without the proper equipment and experience to perform the job.
- 2.28 Always maintain the correct tire pressure. Do not inflate the tires above the recommended pressure. Never weld or heat a wheel and tire assembly. The heat can cause an increase in air pressure resulting in a tire explosion. Welding can structurally weaken or deform the wheel.
- 2.29 Never operate machine in a closed area where dangerous carbon monoxide fumes can collect.
- 2.30 Let engine cool before storing!!!
- 2.31 Hydraulic hoses and lines can fail due to physical damage, kinks, age, and exposure. Check hoses and lines regularly. Replace damaged hoses and lines.
- 2.32 Park machine on level ground. Never allow untrained personnel to service machine. Understand service procedure before doing work.

SECTION 3: MOWER OPERATION

Never operate the machine with faulty equipment. Always be alert of sudden changes in landscape, as the mower will react differently on slopes or embankments than it will on flat surfaces. Never operate the mower with the discharge chute open. Do not cross terrain, other than grass, with blades turning. This could cause damage to property or bystanders.

- 3.1 Place parking brake in up position
- 3.2 Drive arms must be in the “open” position. While sitting on the machine, each arm is positioned away from the operator, to the right and left. Drive arms will lock into place and must be in this position to start machine.
- 3.3 Put PTO switch in the OFF position.
- 3.4 If your machine has been equipped with a ROPS (Roll Over Protection System) then you must fasten seatbelt.
- 3.5 If machine has not been started recently, engage the choke.
- 3.6 Make sure nothing is under or around machine.
- 3.7 Place key in ignition and turn.
- 3.8 Once machine is started, disengage the choke.



- 3.9 Increase RPM by sliding the throttle to fast position, toward the rabbit.
- 3.10 Owners must become familiar with the controls before operating a zero-turn radius vehicle.
- 3.11 Start slowly and build your skill level. Have ample practice before using the machine at full capabilities.
- 3.12 Be comfortable with machine before engaging blades. Know what each component controls before using machine.
- 3.13 Your mower will perform differently on an incline /decline. Be cautious, slow down, and do not make any sudden jerking movements with control arms. The machine could lose traction on a decline or tip backwards on an incline.
- 3.14 Once you become comfortable with your Bad Boy Mower you will notice your overall mowing time will decrease.

Avoid operating your mower on side hills of over 5 degrees, inclines of over 10 degrees, and declines of over 15 degrees.

SECTION 4: MOWER MAINTENANCE

*****Check each and provide maintenance when needed.***

DAILY

- 4.1 Check Engine Oil
- 4.2 Check Engine Air Filter
- 4.3 Tire Pressure
- 4.4 Inspect Blades

Within FIRST five hours of usage, change engine oil and filter

EVERY 30 HOURS OF USAGE

- 4.5 Grease Machine

EVERY 50 HOURS OF USAGE

- 4.6 Change Engine Oil and Filters

Check filters once a year if under 50 hours

Check air and fuel filters more often in dry, dusty conditions

Within FIRST 50 hours of usage, change hydraulic oil and filters

EVERY 250 HOURS OF USAGE

- 4.7 Change Hydraulic Fluid and Filters
- 4.8 Refer to manufacturer manual for specific information on maintenance schedules.

SECTION 5: MOWER STORAGE & TRANSPORTATION

- 5.1 Keep machine from collecting debris by storing in a covered area while not in use.
- 5.2 Fuel can harm your machine if left for more than 30 days without changing, especially if the fuel contains ethanol. Never use fuel with more than 10% ethanol by volume. E-15 is not permitted.
- 5.3 Disconnect the negative battery cable when machine will be stored for more than 30 days.
- 5.4 Always secure machine properly when transporting machine.
- 5.5 Do not load machine on trailer with blades engaged.
- 5.6 Do not use ramps to load the machine.
- 5.7 Make sure Parking Brake is in “up” position.
- 5.8 In wet conditions tires may spin while loading / unloading. If necessary, wait for dry conditions before loading / unloading.
- 5.9 Make sure mode of transportation is suitable to bear the weight of mower.
- 5.10 Deck height should be set at maximum before attempting to load.
- 5.11 Secure mower with at least two straps capable of securing weight of mower.

SECTION 6: TROUBLESHOOTING

- 6.1 **Q: *How do I prevent an uneven cutting pattern and increase the quality of cut?***
- 6.1 **A:** Check tire pressure, check blade sharpness (replace blades or sharpen at least once per year or when needed), make sure blades are tightened properly, check spring and belt tension, check the underside of the deck to ensure the mower deck is free of grass build-up and debris, make sure your machine is at full throttle, and vary your mowing pattern each time you cut your grass.
- 6.2 **Q: *What should I do if my mower won't start?***
- 6.2 **A:** Check battery charge and connection (grounds), check your fuel (make sure fuel is less than 30 days old and contains no water), make sure your spark plug is in good condition and spark plug wire is attached, and make sure air filter is clean (a dirty filter makes it more difficult for the engine to draw air). Check for broken wires or bad connections.
- 6.3 **Q: *What should I do if the blades won't engage?***
- 6.3 **A:** Make sure the safety switch is plugged in on the bottom of seat. Check the underside of the PTO engager to ensure the plug is secure at switch.
- 6.4 **Q: *What type of fuel is recommended for my mower?***
- 6.4 **A:** We recommend that you use a name brand diesel fuel to ensure quality.



- 6.5 **Q: Do you offer touch-up paint for your mowers?**
6.5 **A:** Touch-up paint is available. Contact your local dealer for more information.
- 6.6 **Q: How durable is the electric deck lift?**
6.6 **A:** The actuator which controls the deck height is designed for moving loads of up to 1000 pounds and has a static holding capability which exceeds 3,000 pounds. Our 1/4" deck weighs approximately 250 pounds which is only 25% of working capability.

SECTION 7: CONTROLS

- 7.1 **Ignition Switch**—Bad Boy Mowers have a three position ignition switch: off, run, and start. With key inserted, rotate it clockwise to START position and release key when engine starts, and switch will automatically return to the RUN position.
- 7.2 **Throttle Control**—A cable is connected to the engine throttle for controlling engine speed. Move lever forward to increase engine rpm, move lever backward to decrease engine rpm.
- 7.3 **Choke Control**—A cable is linked to manually operate the engine choke. When the lever is in the down position, the choke is in the off (run) position. When the lever is pulled up, the choke is in the on (start) position. Do not operate the machine in the on (start) position. The choke lever is behind the throttle control.
- 7.4 **Control Levers**—These levers control the mower's speed, direction, and neutral lock. These levers are used to steer, accelerate, decelerate and change direction. (Drive Arms)
- 7.5 **Blade Engage Switch**—This switch engages the blades. Pull the switch up to engage the blades and push the switch down to disengage the blades.
- 7.6 **Deck Lift Control**—The deck lift switch is used to raise and lower the deck. Pull the switch backwards to raise the deck and push the switch forward to lower the deck.

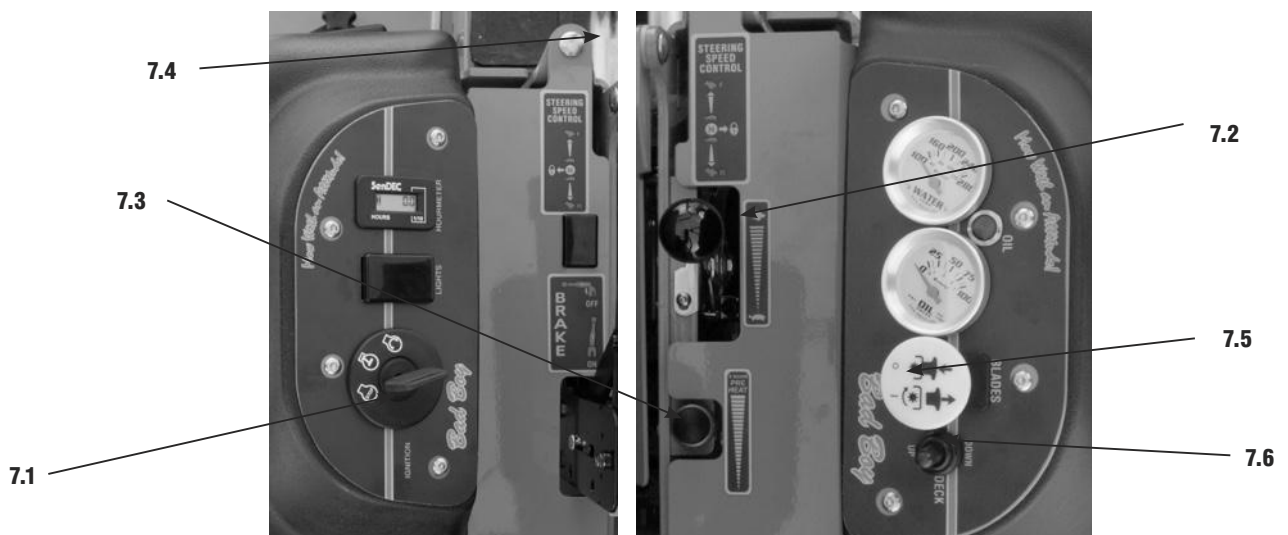

SECTION 8: MOVING INOPERABLE MOWER

- 8.1 Do not tow machine. Use a winch to load on a trailer for transporting.
- 8.2 **ATTENTION:** RETURN BYPASS VALVES TO OPERATING POSITION BEFORE RUNNING MOWER FOLLOWING REPAIRS.
- 8.3 Diesel Models are equipped with two neutral engage/disengage arms, located at the rear of the mower protruding from the frame and under the muffler. By pulling the arms out the mower can be put in a neutral position. Return the arms to the “forward position for normal operation.
- 8.4 Your Bad Boy Mower Weighs: **Diesel SERIES:** **1607—1935 lbs**
**** Weights fluctuate with the addition of accessories.*
- 8.5 As you can see by the weights of the machines, you shouldn't ever try to push or pull a Bad Boy Mower by hand. This could cause serious bodily injury.
- 8.6 Hopefully, you'll never need to use this section of the manual. However, if you do, use extreme caution when moving machine!

SECTION 9: INSTRUMENTATION

- 9.1 **Electronic Hour Meter**—Registers Hour increments up to 9,999.9 total hours. This meter records the cumulative time the engine is running.



SECTION 10: MOWER BLADE MAINTENANCE

- 10.1 Check mower blades after each use. This is essential for maintaining well-groomed turf. Keep the blades sharp. If a dull blade is used for cutting, the grass will tear rather than cut. This could damage the grass leaving a brown frayed top on the grass within a few hours. A dull blade will also require more power from the engine.
- 10.2 NEVER attempt to straighten a bent blade by heating. NEVER attempt to weld a cracked blade. The blades can break and cause serious injury or death.
- 10.3 NEVER work with blades while engine is running or deck clutch is engaged.
- 10.4 ALWAYS place deck clutch in DISENGAGE position while performing maintenance.
- 10.5 Use blocks when you MUST work under mower.
- 10.6 ALWAYS wear thick gloves when handling blades.
- 10.7 ALWAYS check for blade damage if mower strikes rock, branch, or other objects that could potentially damage the blade. **(REMEMBER: NEVER CHECK BLADE WHILE ENGINE IS ON! NEVER CHECK BLADES WHILE BLADES ARE ENGAGED!)**

SECTION 11: GREASING THE BEARINGS

- 11.1 Park the machine on a level surface and disengage the blade control switch.
- 11.2 Move the motion control levers outward to the neutral position, engage parking brake, stop the engine, remove the key, and wait for all moving parts to stop before leaving the operating position.
- 11.3 Grease Type: NLGI grade #2 multi-purpose gun grease. Grease the front cater pivots.
- 11.4 Clean the grease fittings with a cloth. Scrape any paint off the front of the fitting(s).
- 11.5 Connect a grease gun to each fitting. Pump grease in fittings until greases begins to seep out of the bearings. Wipe up excess grease.
- 11.6 Refer to service manual section for grease fitting locations.

HOW TO CHOOSE THE RIGHT BLADE

Essentially there are only TWO basic styles of mowing blades used or approved for use on our current products:

- 1) The standard style of mowing blade is essentially designed for cutting grass and effectively discharging the clippings out from the deck to fall onto the lawn or to be captured in a grass collection system. Standard blades are also referred to as “2-in-1” (discharging & bagging) or “high-lift” blades (because they are designed to create a higher-lifting airflow).
- 2) Mulching blades generally have a more curved style surface and frequently include extra cutting surfaces along the blade edges. These blades may also come in a “+” design (which is actually two individual blades arranged in a perpendicular fashion to enhance mulching). The “+” blades are usually found on older style mowers; newer ones utilize blades with more advanced mulching technology. Mulching blades may also be referred to as “3-in-1” (mulching, discharging & bagging) or “all-purpose” blades.

Bear in mind that the re-circulating airflow design of 3/1 blades makes them less efficient at discharging grass clippings than a standard 2/1 blade. As with most all-purpose tools, there is some give and take as opposed to using a tool designed for a more specific purpose.

If you're experiencing less-than-desired cutting or discharging performance with a 3/1 blade, you may want to check into using a 2/1 blade. Conversely, if you're using a 2/1 blade and want to mulch clippings, you should see about the availability of mulching blades or a mulching kit.*

The type of blade installed on a new mower is a decision the retailer makes for each model of mower, based on the expected needs of most customers. If you're unsure of which blade is on a particular model, inspect the blade. Blades have part numbers stamped into them. Then compare these part numbers with the unit's Operator's Manual or Parts List.

It is true there are many other styles of blades available. But since we don't manufacture or recommend using these other aftermarket styles, we will leave them out of this discussion. Should you want more information on special application or aftermarket blades, you should contact the companies that make these products. NOTE: Customers using non-OEM blades do so at their own risk. The use of unapproved (non-OEM) blades may void any or all of the mower and engine factory warranties.

* **MULCHING KITS** – These generally consist of mulching blades and a mulching plug (which closes off the discharge opening to keep the clippings contained under the deck for re-cutting) plus any necessary hardware for installation. Please check with your parts distributor regarding the contents of a particular mulching kit.



SERVICE SECTION

SECTION 1: HYDROSTATIC SYSTEM

To change hydro oil on Pup, Lightning, AOS, and Diesel models, remove oil return lines from top of hydro tank and place them in a disposable oil container. Start and run mower until oil level is reduced down to about 2" of oil remaining in the tank. Do not allow air to enter the oil lines in the bottom of the tank. Keep in mind that only about 75% of the hydro oil can be changed at a time. Use only 20w50 motor oil in the hydro system. (Conventional or synthetic oil may be used) Bad Boy recommends that the hydro oil and filters be changed within the first 50 hours of usage and every 500 hours thereafter or once a year. (Pup, Lightning, AOS, and Diesel Models)

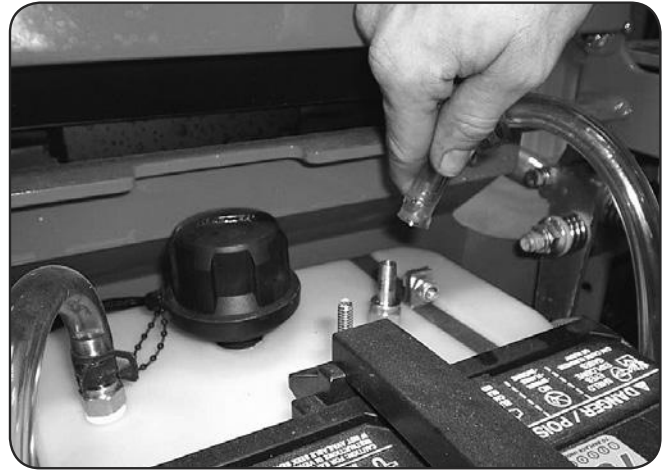

Change hydro oil filters by unscrewing them from the filter head. Fill new filters with 20w50 motor oil before installing. Use only Bad Boy replacement filters. Using any other filter will result in damage to the hydro system and void the warranty.



Once the system is refilled with oil, lift rear of mower until tires are off the ground. Start engine, release parking brake, stay clear of moving rear tires, loosen bypass bolt $\frac{1}{2}$ to $\frac{3}{4}$ turns, move drive arms forward and backward 4 to 6 times slowly. This will purge the air from the system. (the bypass bolt has a hole drilled through the side of the bolt head). This valve also serves as a neutral for moving the mower without the engine running.

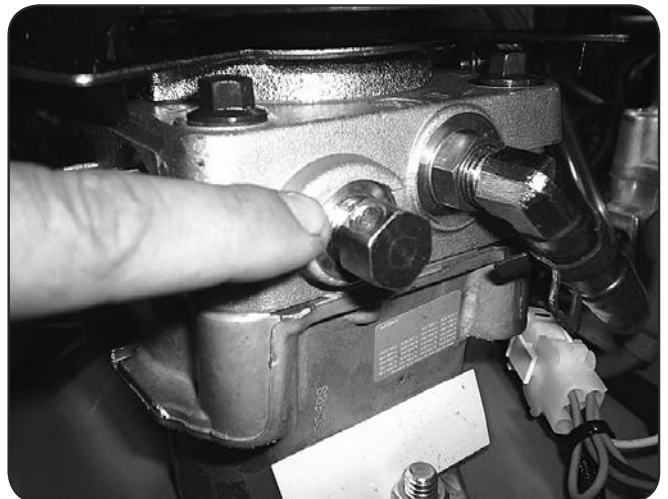

SECTION 2: DRIVE BELT

Shown above is a typical pump belt tensioner for Pup and Lightning models.

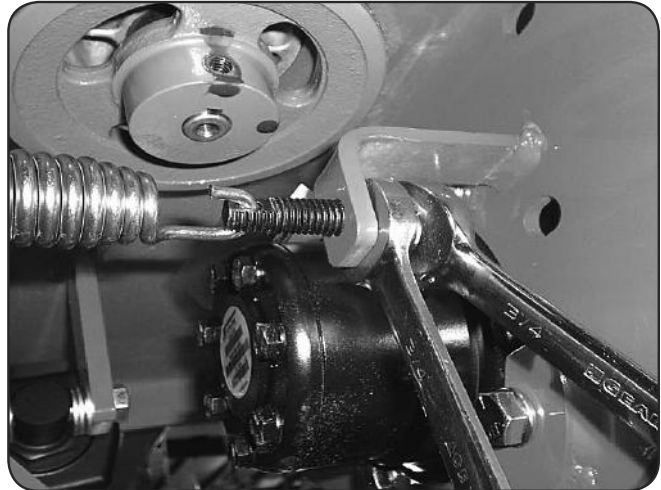

Factory setting is about .030" (about the thickness of a credit card) between coils as shown.

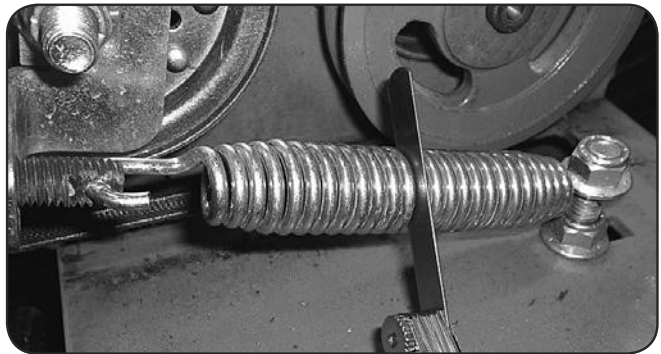

Shown to the right is a typical pump belt layout for most models.

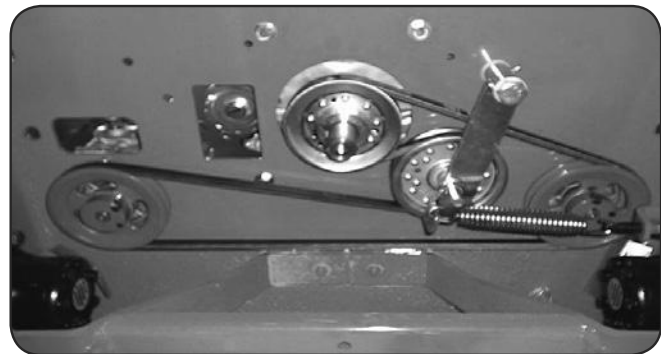

SECTION 3: ENGINE

When servicing the fuel system on the CAT Diesel, it is necessary to purge the air from the system by loosening the 9/16" bolt on top of the fuel filter and pumping the fuel bulb (located underneath the radiator) until air bubbles are no longer visible.

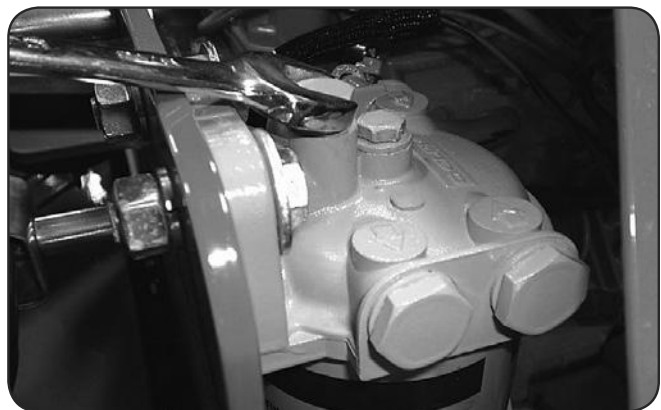



Most models have a drain hose installed on the engine, for easier oil changes. All gas engines used by Bad Boy use 10w30 and have an oil capacity of 2 quarts. Bad Boy recommends that the oil and filter be changed every 50 hours of usage.

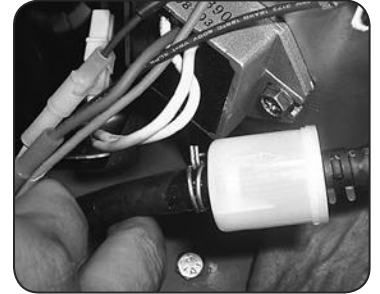

The fuel filter is located in the fuel line about 12" from the carburetor on the side of the engine. Note the direction of flow on the side of the filter. Replace once a year.

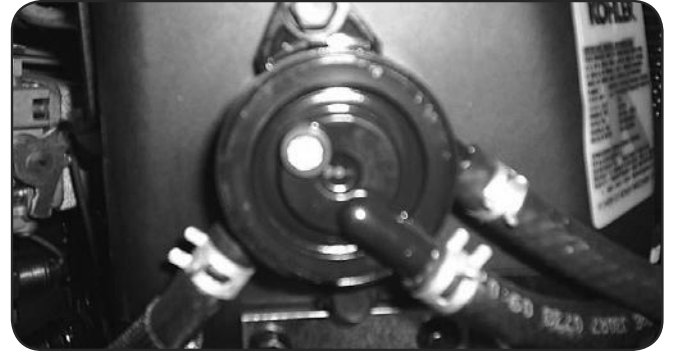

Most all models have a vacuum operated fuel pump bolted to the side or top of the engine. The pump has a "fuel in", a "fuel out", and a vacuum line coming from the engine block. Fuel flow can be checked here if the pump is suspected to be defective.



Remove and inspect air cleaner weekly. (More often in dusty conditions). Do not blow filter out with air pressure, this will cause the filter to be filled with tiny holes that will allow dirt to enter. Instead, tap filter on side to remove any debris. Replace at least once a year, more often in dusty conditions.

Torque the clutch bolt to 50 ft. Lbs. on all models. Retorque at every oil change. (All Models)

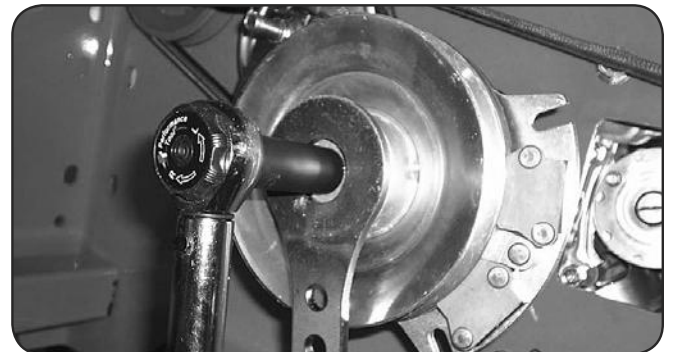

Keep radiator screen clean and free of debris on liquid cooled models. Check screen hourly during dry conditions. Slide radiator screen up to remove.

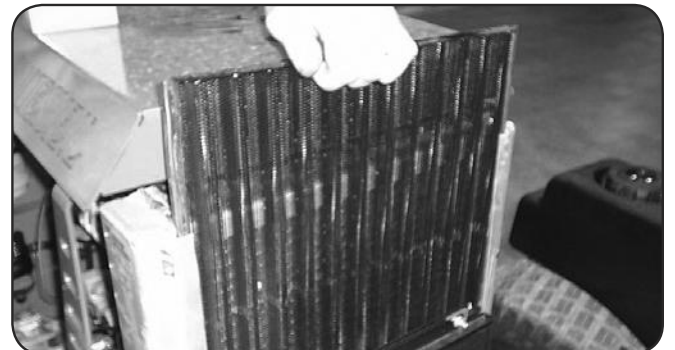

SECTION 4: ELECTRICAL SYSTEM

On most larger commercial engines (27 hp and up), the 25 amp main fuse is located about 3" from the starter on the engine. (shown in first image on right). On smaller commercial and light duty commercial mowers, the 25 amp main fuse is located just behind the battery connected to the starter solenoid. (Shown in second image on right).

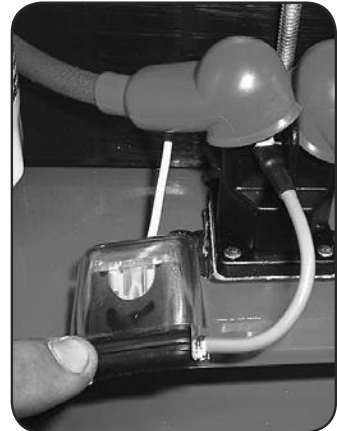
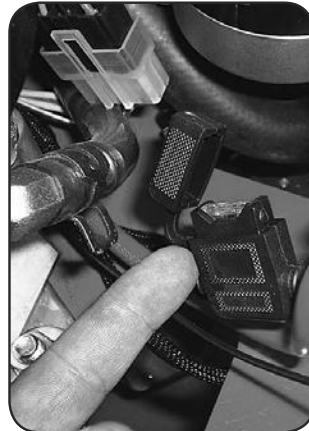

Always check the condition of the wiring harness ground cable. The ground is located just inside of the right side fuel tank on most models. Ensure that the ground is connected, clean, and tight. On some models, this wire may be connected to the negative side of the battery.

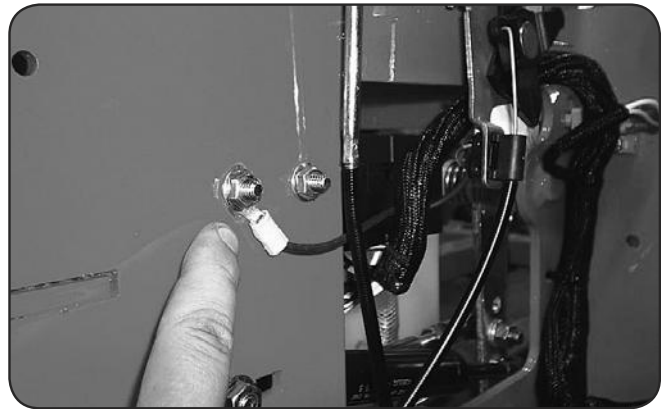

Check the condition and connection of the relays located under the seat. Ensure that they are clean and connected. Make sure that wire terminal ends have not been pushed out of the relay block.

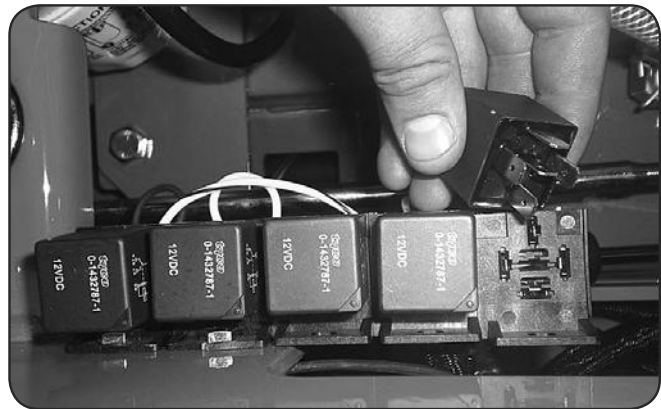

On most models, the red wire coming out of the engine is the charging wire from the alternator. Check for 13.6—14.2 volts DC at this wire with engine at full throttle.



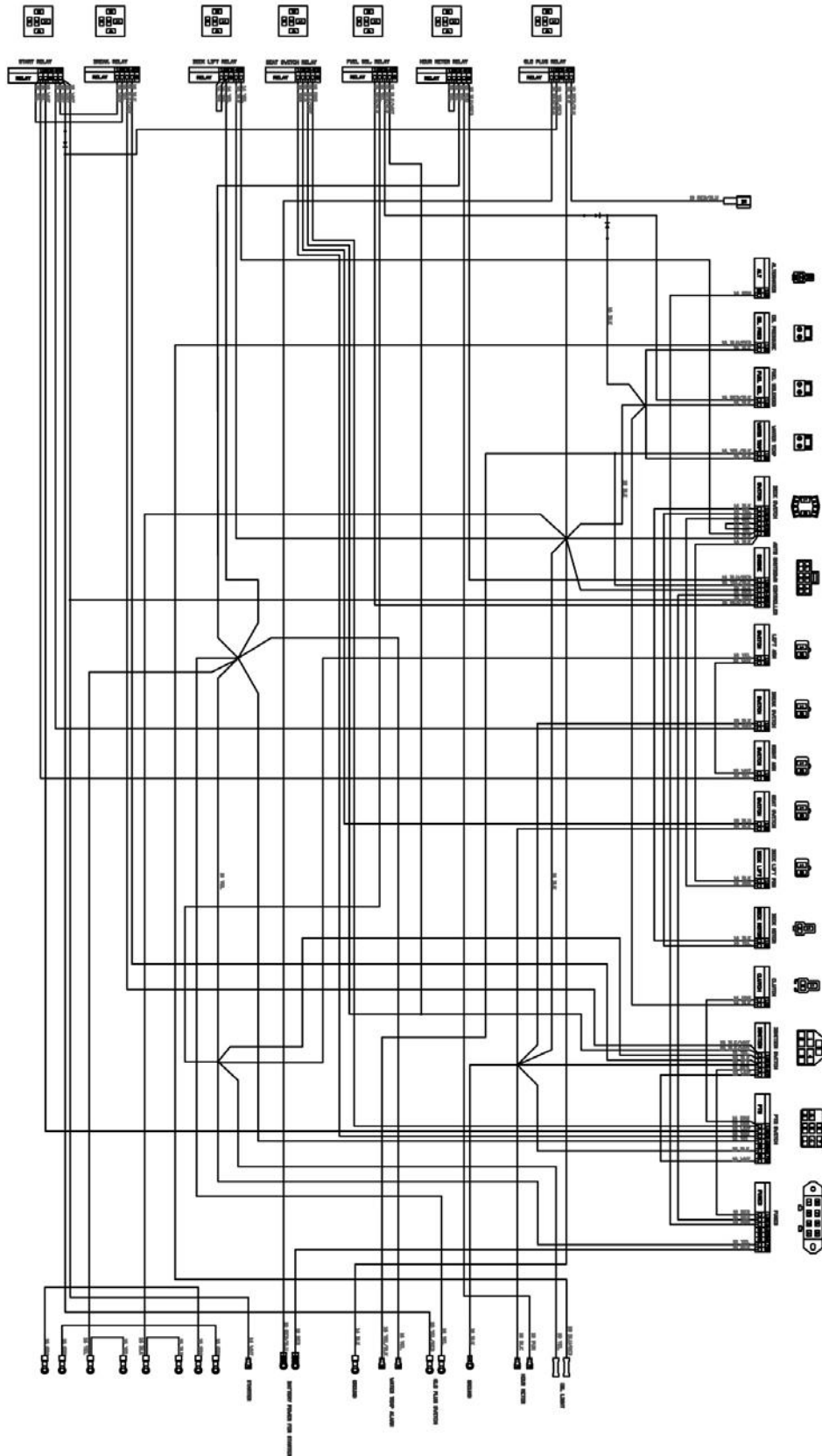

THESE WIRING DIAGRAMS ARE THE PROPERTY OF ELECTREX, INC. AND ARE NOT TO BE REPRODUCED OR TRANSMITTED IN ANY FORM OR BY ANY MEANS, ELECTRONIC OR MECHANICAL, INCLUDING PHOTOCOPYING, RECORDING, OR BY ANY INFORMATION STORAGE AND RETRIEVAL SYSTEM. ELECTREX, INC. IS NOT RESPONSIBLE FOR ANY DAMAGE TO PROPERTY OR PERSONS ARISING FROM THE USE OF THESE WIRING DIAGRAMS.

ELECTREX, INC.
1000 W. 10TH AVENUE
DENVER, CO 80202
TEL: 303.733.1111
FAX: 303.733.1112
WWW.ELECTREX.COM

TECHNICAL SERVICE
FOR INVESTIGATIONS
AND REPAIRS
CALL 1-800-555-1111
OR 303-733-1111
TOLL FREE
IN COLORADO
303-733-1111

TECHNICAL SERVICE
FOR INVESTIGATIONS
AND REPAIRS
CALL 1-800-555-1111
OR 303-733-1111
TOLL FREE
IN COLORADO
303-733-1111

TECHNICAL SERVICE
FOR INVESTIGATIONS
AND REPAIRS
CALL 1-800-555-1111
OR 303-733-1111
TOLL FREE
IN COLORADO
303-733-1111

SECTION 5: FRAME

For non-suspension models, torque front fork castle nut to 40 ft.lbs. Be sure to spin the fork while torquing the nut to ensure that no bearing damage is done.

Be sure to reinstall the cotter pin into the castle nut. Always try to go tighter on the nut to find a castellation for the pin to fit in. Never back the bearing tension off after torquing the nut, this will “spring” the bearing cage.

Torque rear wheel lugs to 65-75 ft.lbs.
Re-torque at every oil change.

There is one grease fitting in each front wheel and one in each front caster bearing housing. Grease at every engine oil change.

There is one grease fitting on each of the actuator bar pillow blocks located under the fuel tanks. Grease twice a season.

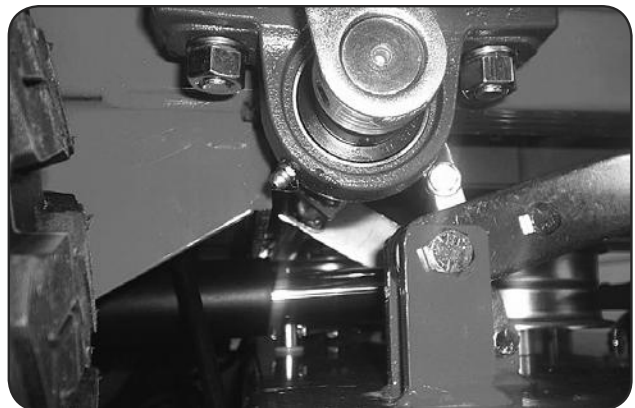



The pump belt tensioner is located under the engine and has a grease fitting at its pivot point. Grease at every engine oil change.



The deck belt tensioner is located at the rear of the deck and has a grease fitting on its pivot point. Grease at every engine oil change.

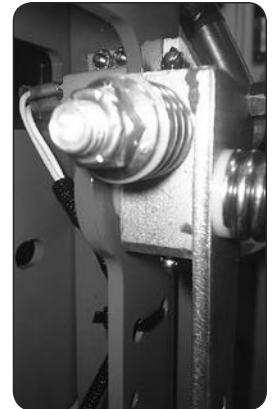

The control arm blocks have grease fittings located on the top and bottom of each block. Grease one time a year.

SECTION 6: CUTTING DECK

To remove the deck belt, lift up on the belt while rotating the pulley to roll the belt up and off of the pulley. (be sure not to get your fingers between belt and pulley).



To check the level of the deck, start on a flat surface and set the air pressure in all four tires. Raise the deck up, and measure all four corners of the deck to see if it is level from left to right and front to back. All decks should be level from left to right and have a 1/8" pitch down in the front.

If deck adjustments are necessary, start with the chain length adjusters. These adjusters affect the overall height of the deck and the level from left to right.

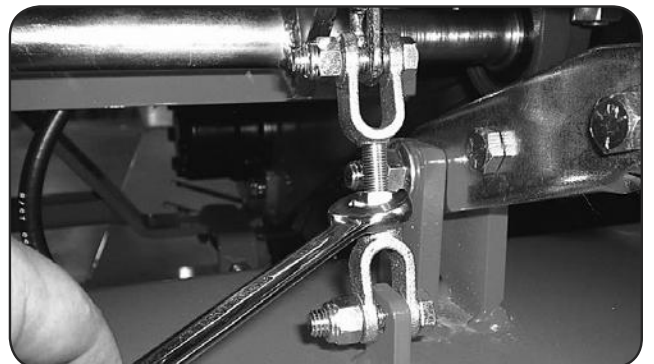

The large turn buckles on the front of the deck only affect the pitch of the deck or the level from front to back.



The deck spring tension is critical. If the tension is too much, it will cause the spring to break. If too loose, the belt can jump off or slip on the pulleys and cause a cut quality issue. With the deck up, the spring coil gap should be about .025" - .030" (about the thickness of a credit card). Spring tension adjustments can be made by sliding the bolt shown above forward or backward in the slot of the deck.



The condition of the blades can drastically affect the cut quality of the mower deck. Replace as necessary. These blades were used considerably too long. Resharpenering is recommended by professionals only to determine when the blade needs to be replaced and because of the need for rebalancing.



To change blades, it may be easier to use a piece of wood to keep the blade from turning so that the bolt can be loosened. Re-torque the blade bolts to 90-110 .lbs.

The blade spindles contain a sealed ball bearing in the top and bottom of the spindle. The bearings are replaceable for a more cost effective repair.

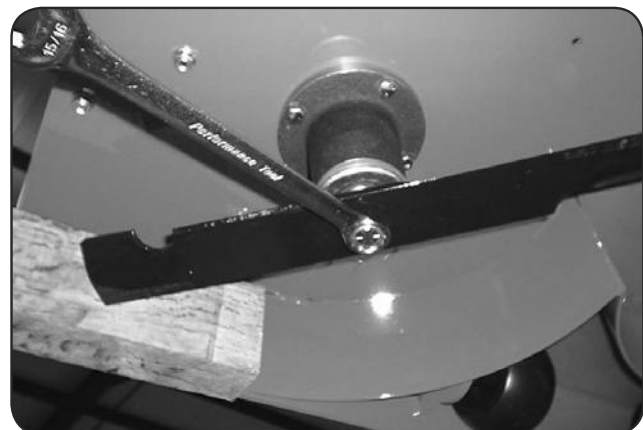



MOWING TIPS:

- Mow header strips at the ends of the lawn and around flower beds first. Make them wide enough that you can turn the mower around in the already mown section. Then mow back and forth between these header strips overlapping each lap by about 1/8 the width of the mower's deck.
- Don't cut your grass too short, particular for cool season grasses. Higher heights usually provide for a deeper root system, looks better, and is less likely to have weeds invading, particularly crabgrass.
- Don't remove any more than one third of the grass leaf at any one cutting. If circumstances arise that a lawn gets too tall and you just have to lop off a bunch to get caught up, bite the bullet and break it down into several mowings to get caught up with 3 or so days between cuttings.
- **NEVER SCALP YOUR LAWN.** Scalping severely damages the root system to such a degree that it may die.
- Avoid mowing when the grass is wet or when it's dark
- Avoid throwing grass clippings into the street and driveway where they can be washed into the sewer system. After mowing, clean up driveway and walkways.
- When mowing remove only a third with each cutting (except for the first mowing of the season when it's ok to remove more). You can safely leave clippings that will quickly decompose and add nutrients back into the soil. Contrary to popular opinion, grass clippings do not add to thatch buildup. Grass blades are made up of about 75% water.
- Mow your lawn in a different direction with each mowing, especially with lawns of shorter grass types. Altering the direction ensures a more even cut since grass blades will grow more erect and less likely to develop into a set pattern.
- Keep your mower's blade sharp, which means having it sharpened several times during the mowing season. Keep several blades around so you'll always have a sharp one on hand. Sharp blades cut the grass cleanly and help mulch clippings into small pieces which break down quickly.
- Don't forget to change your mower's oil at least once during the mowing season. For brand new mowers, change the oil after about 5 hours of operation during the initial break-in period.
- At the end of the mowing season use a fuel stabilizer in the remaining gasoline
- In the spring, don't use that old gas unless you properly used a fuel stabilizer, it can cause a number of problems. Better to use fresh gasoline to begin the new mowing season.
- **Leaf blade A** demonstrates what a leaf blade should look like after mowing with a sharp blade.
- **Leaf blade B** demonstrates a leaf blade that was injured by a dull mower blade.
- **Leaf blade C** was cut by the mower but indicates that the mower blade is not sharp enough. The shredded white tissue protruding from the leaf blades C and D is the vascular tissue of the plant.
- **Leaf blade D** has been mown for quite some time with a dull mower blade.

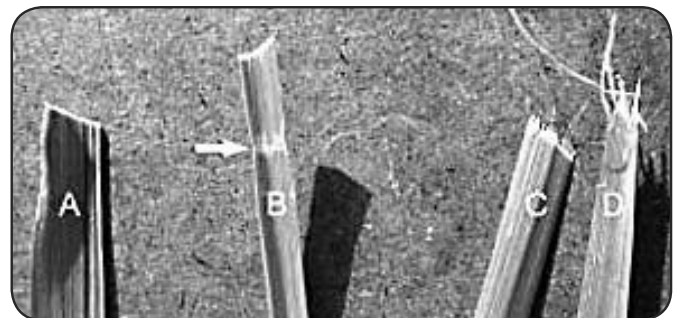

To bag or mulch?

Grass clippings do not contribute to thatch buildup or increase the chances of disease. If you mow your lawn at the right height, without removing any more than 1/3 of it's total height, clippings will quickly breakdown without a trace. These clippings contribute additional nitrogen and other nutrients to the soil and supply it with additional organic materials. Clippings from a 1000 sq. ft. lawn can add as much as 1 - 2 pounds of nitrogen back into the soil.

If you have a compost pile, then you may want to bag your clippings occasionally to add much needed green-matter to the compost pile. Make sure it is mixed thoroughly with brown matter to avoid a strong ammonia odor. **DO NOT COMPOST CLIPPINGS** after applying any weed control or weed-feed type product. Before adding clippings to the compost pile wait at least 3 mowings after these products have been applied.

PARTS SECTION

Floor Board

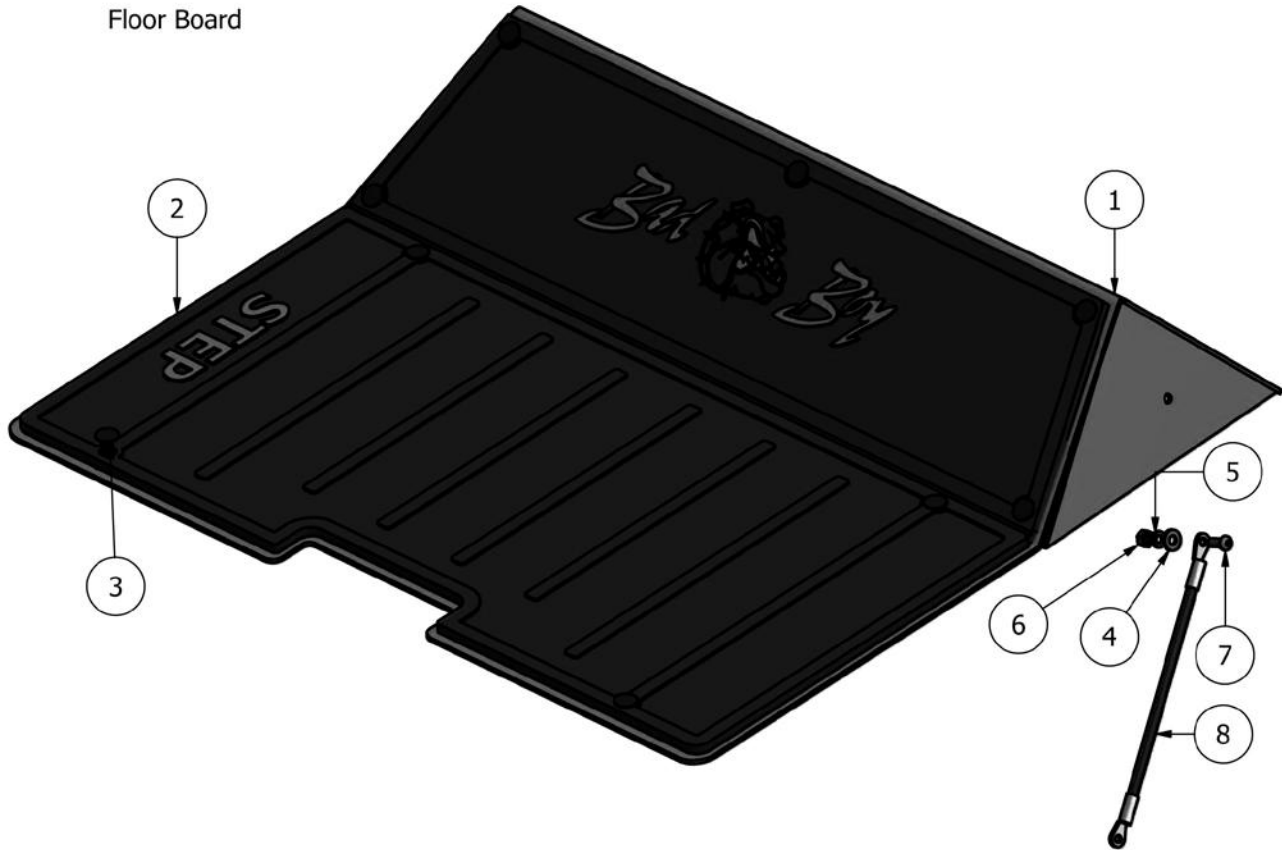

Parts List			
ITEM	QTY	PART NUMBER	DESCRIPTION
1	1	079-6000-00	Floor Panel
2	1	081-2007-00	Floor Mat
3	9	040-6080-00	Ratchet Fastener
4	1	019-7040-00	1/4" Flat Washer
5	1	019-4008-00	1/4" Lock Washer
6	1	013-8039-00	1/4" Hex Nut
7	1	018-8064-00	1/4" x 5/8" Buttonhead Bolt
8	1	064-2006-00	Floor Panel Cable

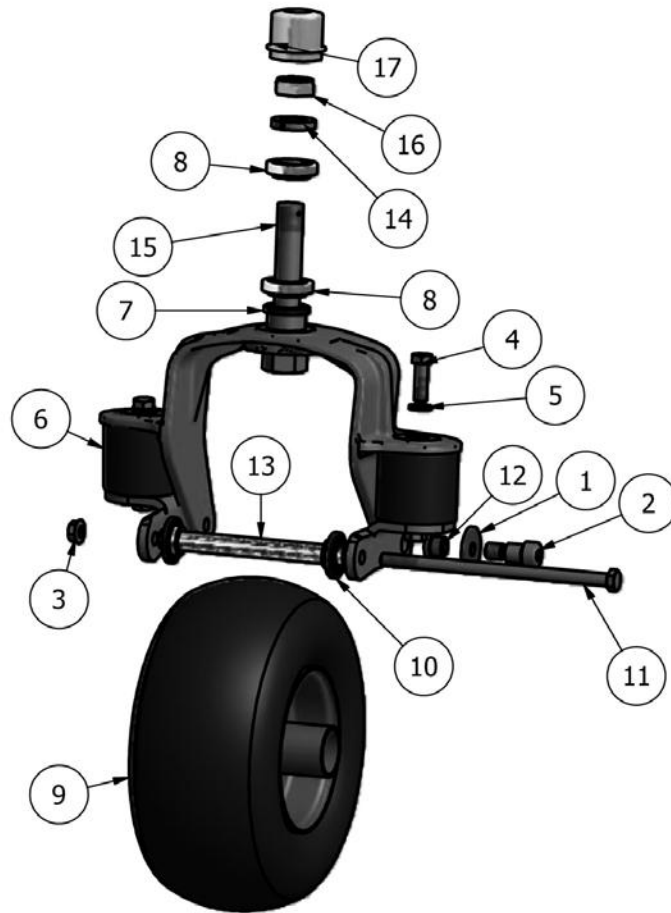

Parts List			
ITEM	QTY	PART NUMBER	DESCRIPTION
1	2	019-5038-00	5/8" Flat Washer
2	2	018-3001-00	5/8" x 5/8" Shoulder Bolt
3	1	013-8050-00	Hex Flange Nut
4	4	018-5600-00	1/2" x 1 1/2" Hex Bolt
5	4	019-5007-00	1/2" Lock Washer
6	2	032-9002-00	Rubber Isolator
7	1	012-7003-00	Seal
8	2	010-7001-00	Bearing
9	1	022-1050-00	13" x 6.50 - 6 No-Flat Tire and Wheel
10	1	022-7010-00	Large Bore Bearing
11	1	018-3002-00	1/2" x 10" Bolt
12	1	032-5052-00	5/8" Shoulder Bushing
13	1	025-5202-00	7" x 1/2" ID Tire Spacer
14	2	019-3000-00	1" Lock Washer
15	1	037-0010-00	Spindle Shaft
16	1	013-9004-00	1" Nylock 1/2 Nut
17	1	014-7005-00	Dust Cover

Adjustable Drive Arm

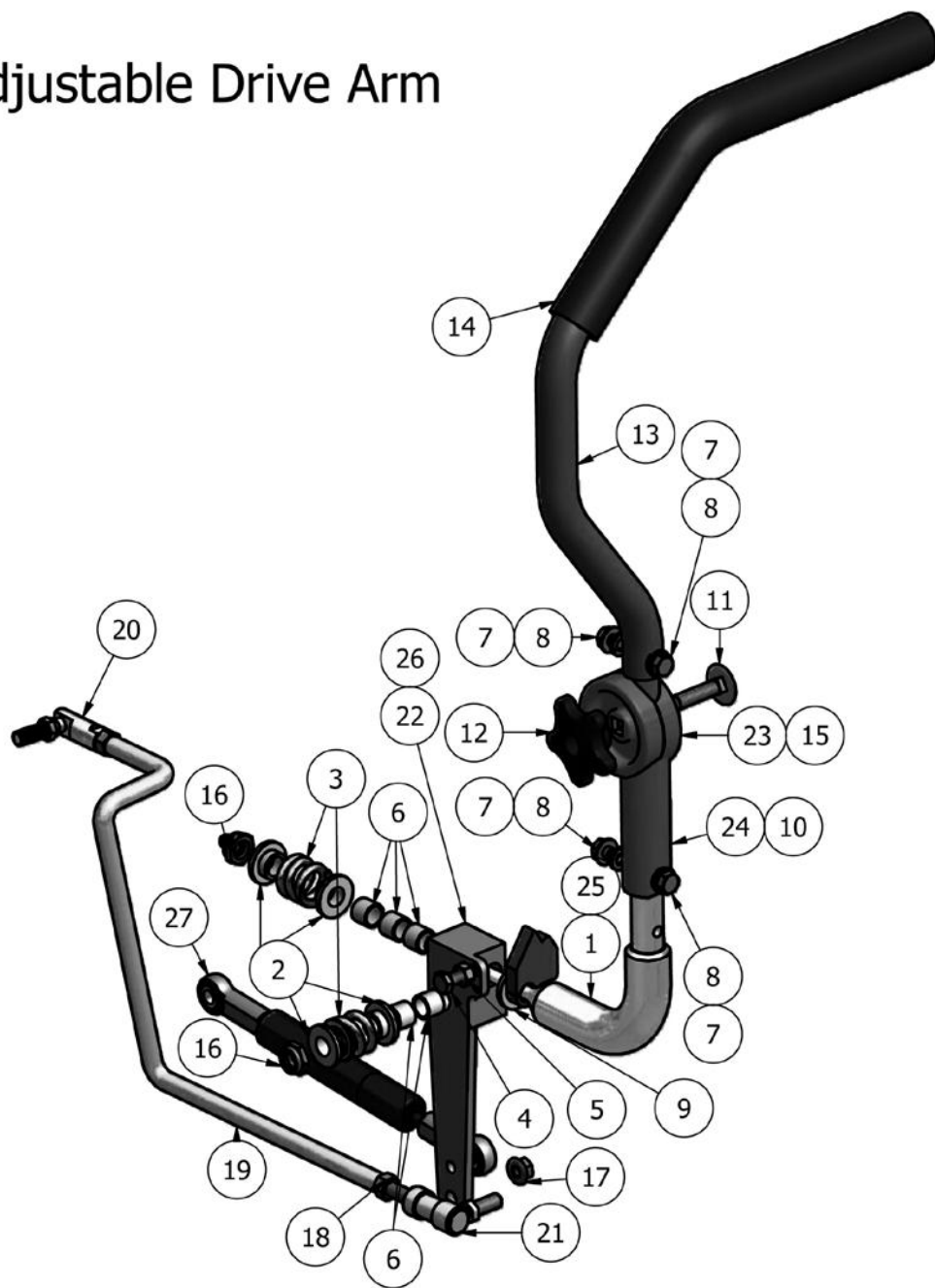



Parts List			
ITEM	QTY	PART NUMBER	DESCRIPTION
1	1	031-9025-00	Steering Arm Base-Right
2	4	019-8027-00	.515 ID Nylon Shoulder Washer
3	2	034-8025-00	Drive Lever Spring
4	1	018-8063-00	5/16" x 3/4" Hex Bolt
5	1	013-8043-00	5/16" Nut
6	5	032-8024-00	.507 ID Nylon Bushing
7	4	019-8051-00	5/16" Lock Washer
8	4	018-2007-00	5/16" x 1/2" Flange Bolt
9	1	019-6017-00	.635 ID Plastic Washer
10	1	031-9017-00	Upper Adjuster for Steering Arm
11	1	018-5043-00	3/8" x 1-1/4" Carriage Bolt
12	1	045-5000-00	Black Knob for Adjustable Steering Arm
13	1	031-9010-00	Upper Steering Arm Tubing-Adjustable
14	1	069-4010-00	Black Steering Grips
15	1	031-9015-00	Lower Adjuster for Steering Arm
16	2	013-6037-00	1/2" Nylock Nut
17	1	013-9002-00	5/16" Flange Nut
18	2	013-6051-00	3/8" Fine Threaded Jam Nut
19	2	035-6050-00	Push Rod for Diesel Left & Right
20	1	099-6046-00	3/8-24 Ball joint (female/male)
21	1	099-2009-00	3/8-24 Quick Release Ball Joint
22	1	027-8819-00	Drive Arm Lever Housing (Left)
23	1	031-9015-00	Lower Adjuster for Steering Arm Right
24	1	031-9016-00	Upper Adjuster for Steering Arm Right
25	1	031-9020-00	Steering Arm Base-Left
26	1	027-8820-00	Drive Arm Lever Housing (Right)

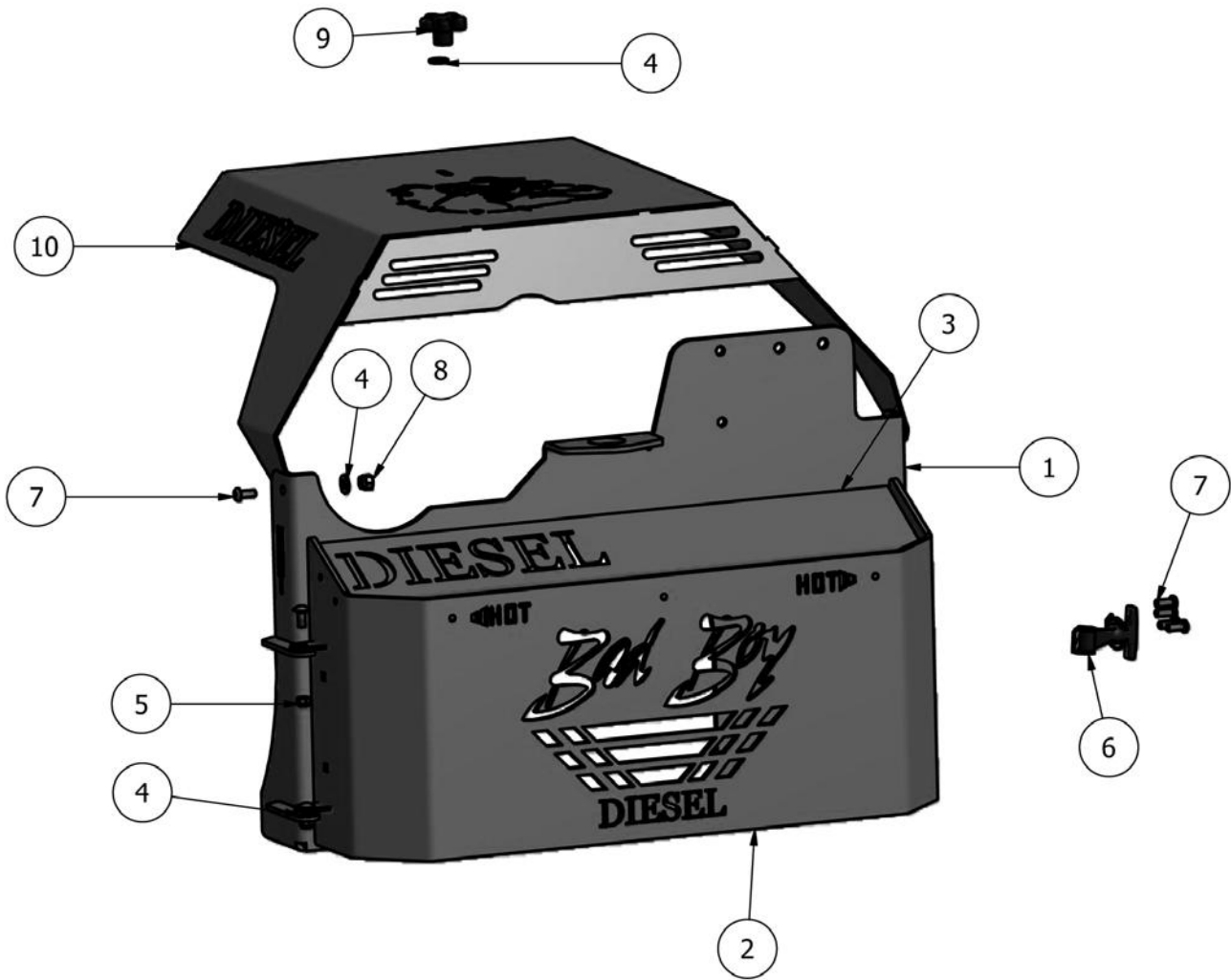

Parts List			
ITEM	QTY	PART NUMBER	DESCRIPTION
1	1	026-8030-00	Pump Plate Diesel
2	1	014-5920-00	Back Pump Cover
3	1	014-5921-00	Top Back Cover
4	4	019-6042-00	.360 ID Plastic Washer
5	2	013-8047-00	5/16" Nylock Nut
6	1	052-2005-00	Metal Pump Cover Latch
7	4	018-5007-00	5/16" x 3/4" Button Head Bolt
8	4	013-5041-00	3/8 Nylock Nut
9	1	045-6043-00	5/16" Knob
10	1	059-8010-00	35 HP Hood

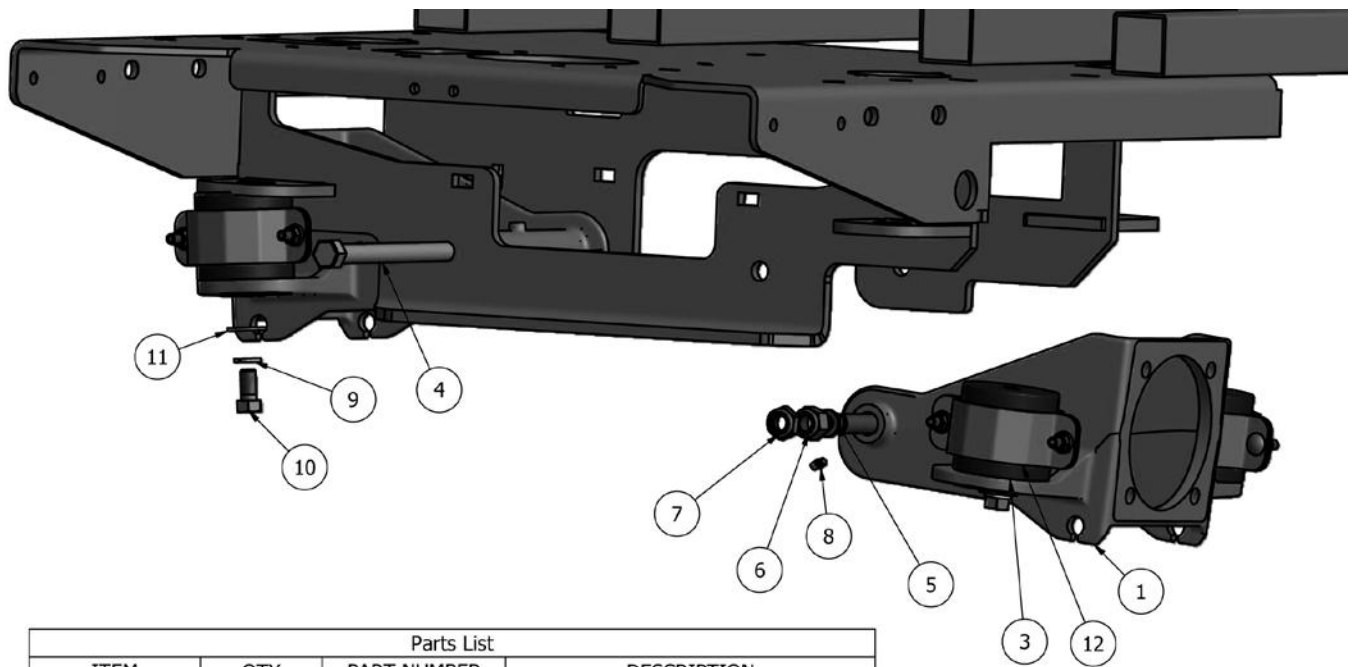

Parts List			
ITEM	QTY	PART NUMBER	DESCRIPTION
1	2	070-8000-00	60" Inner Suspension Cage
3	2	032-9000-00	Vibration Mount-Green Dot
4	2	018-2051-00	5/8" x 10" Hex Bolt
5	4	032-5051-00	Shoulder Spacer
6	2	013-5020-00	5/8" Nut
7	2	013-5301-00	5/8" Nylock 1/2" Jam Nut
8	2	024-6034-00	Grease Fitting
9	4	019-5007-00	1/2" Lock Washer
10	4	018-6019-00	1/2" 1 1/2" hex Bolt
11	4	019-5702-00	1/2" flat Washer
12	4	072-1000-98	Isolator band Clamp Assembly

Diesel Tanks

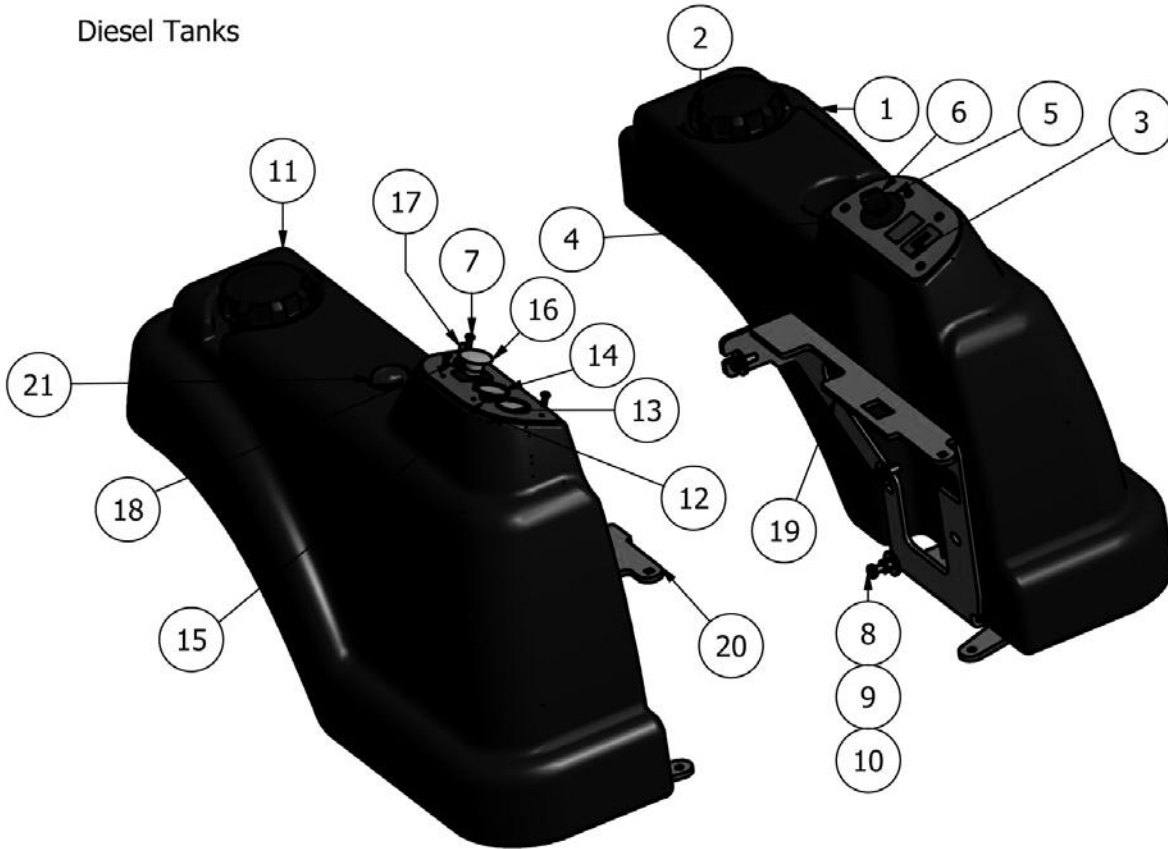

Parts List

ITEM	QTY	PART NUMBER	DESCRIPTION
1	1	067-3000-00	Left Fuel Tank
2	2	066-8090-00	Diesel Fuel Cap
3	1	083-4014-00	Hourmeter-Diesel
4	1	079-3402-00	Control Panel (Left)
5	1	077-8076-00	Ignition Switch
6	1	042-9000-00	Ignition Key
7	8	018-2010-00	10-32x 3/8" Button Socket
8	10	018-5015-00	5/16" x 1" Hex Bolt
9	10	019-8051-00	5/16" Lock Washer
10	10	019-8044-00	5/16" Flat Washer
11	1	067-3001-00	Right Fuel Tank
12	1	079-3403-00	Diesel Control Panel (Right)
13	1	086-5001-00	Oil Guage With Sender
14	1	086-5000-00	Temperature Guage With Sender
15	1	089-1000-00	Oil Light
16	1	056-8058-00	PTO Engager
17	1	078-8077-00	Deck Lift Joystick
18	1	014-8077-00	Joystick Cover
19	1	031-2007-00	Tank Support-Left
20	1	031-2006-00	Tank Support-Right
21	1	067-4025-00	Fuel Gauge & Grommet

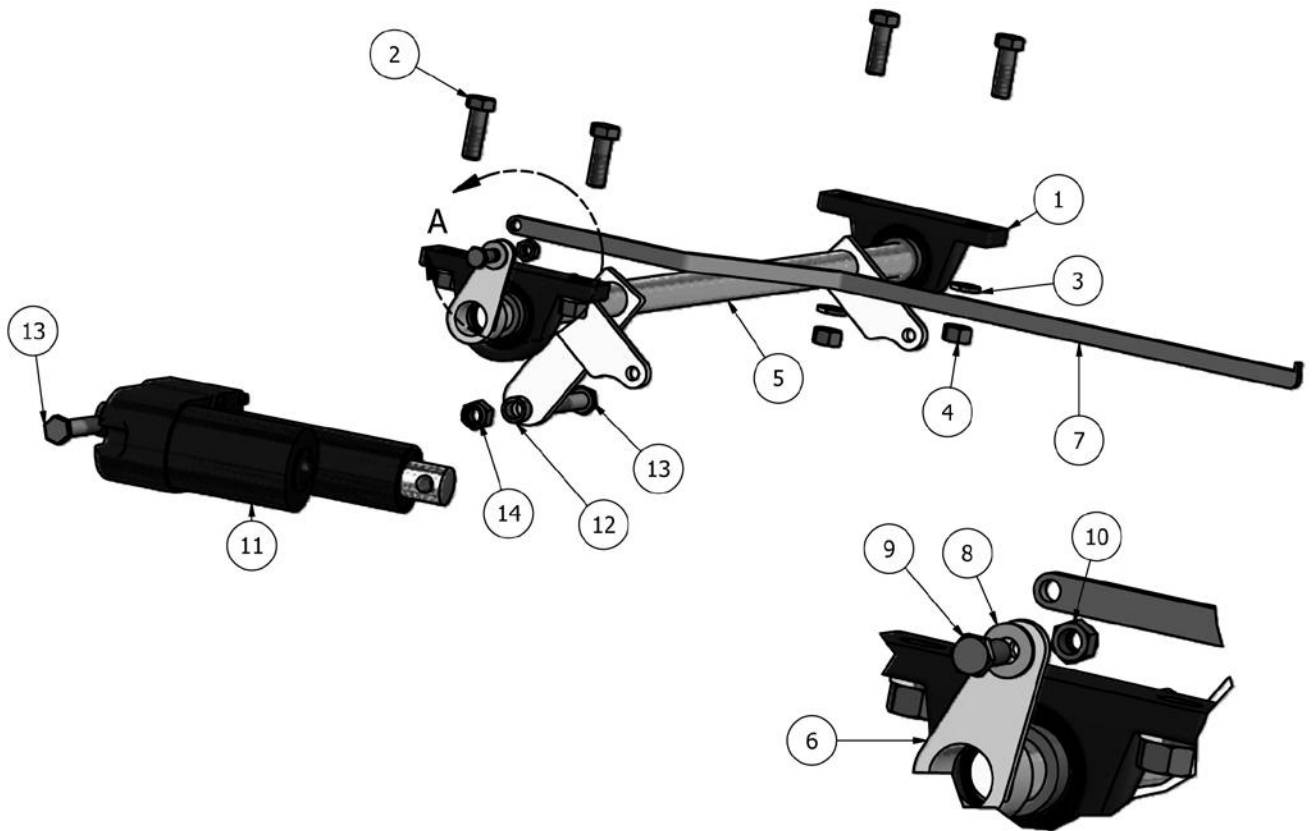

DETAIL A

Parts List			
ITEM	QTY	PART NUMBER	DESCRIPTION
1	2	017-7008-00	Pillow Block 2Bolt Sealmaster
2	4	018-5600-00	1/2" x 1 1/2" Hex Bolt
3	4	019-5007-00	1/2" Lock Washer
4	4	013-7018-00	1/2" Hex Nut
5	1	028-7930-00	Actuator Bar Diesel
6	1	031-7000-00	Height Indicator Lever
7	1	028-2501-00	Height Indicator
8	1	019-6042-00	.360 ID Plastic Washer
9	1	018-6049-00	3/8" x 1" Hex Bolt
10	1	013-5041-00	3/8 Nylock Nut
11	1	035-7033-00	Actuator
12	2	025-7036-00	1/2 x 1/2 Spacer
13	2	018-7016-00	1/2" x 3" Hex Bolt
14	2	013-6037-00	1/2" Nylock Nut

Wheel Motor/Tire and Wheel Assembly

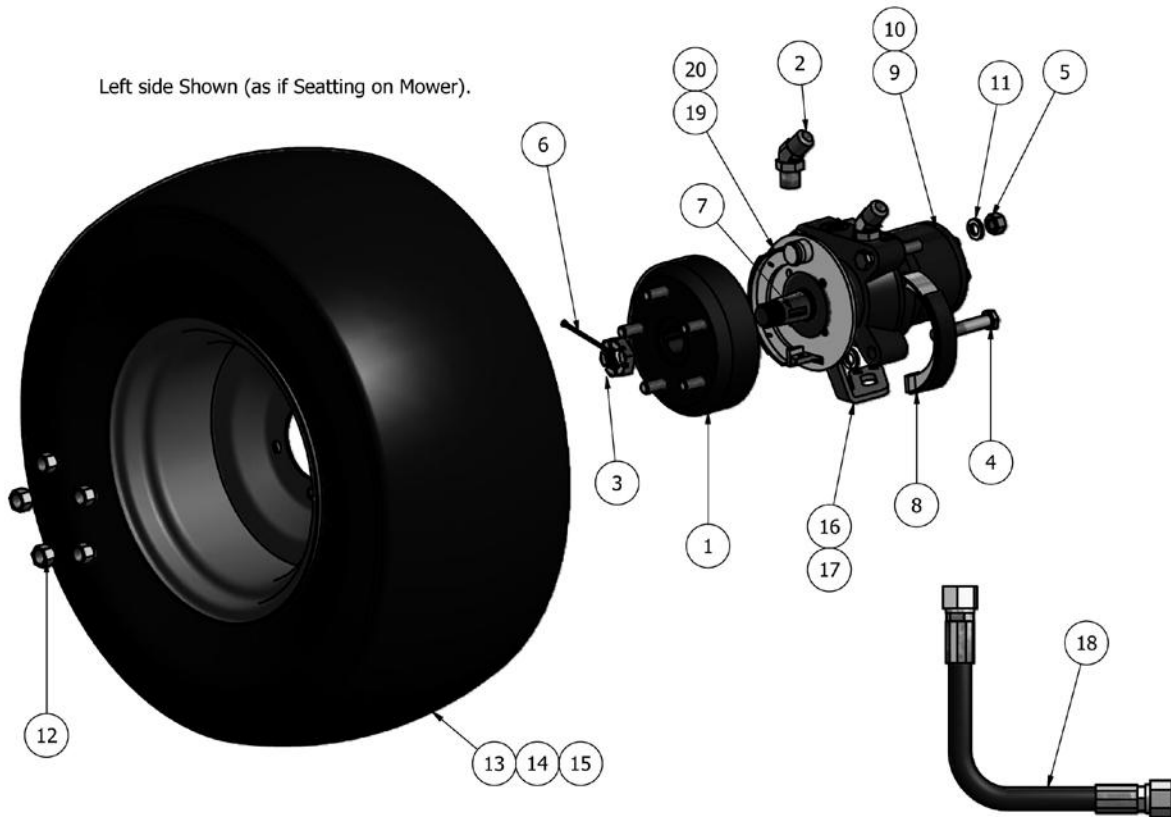

Parts List			
ITEM	QTY	PART NUMBER	DESCRIPTION
1	1	092-2075-00	Brake Drum
2	2	024-2050-00	Hydraulic Fitting
3	1	013-9004-00	1/2" Castle Nut
4	4	018-7016-00	1/2" - 13 x 3" GRS Hex Bolt Zinc
5	4	013-7018-00	1/2" Hex Nut
6	1	020-7022-00	1/8"x2 1/4" Cotter Pin
7	1	042-7041-00	Woodruff Key
8	2	092-6050-00	Brake Shoe
9	1	015-4600-00	Wheel Motor 18cc Right Parker
10	1	015-4601-00	Wheel Motor 18cc Left Parker
11	4	019-5007-00	1/2" Lock Washer
12	5	013-3000-00	Lug Nut
13	1	022-7034-00	12" Rim
14	1	022-7032-00	26" x 12-12 Tire -60" & 72" Cut
15	1	022-7031-00	26" Tire and Wheel Assembly
16	1	031-0011-00	Brake Lever (wheel motor) Left
17	1	031-0012-00	Brake Lever (wheel motor) Right
18	2	051-6085-00	26" Hydraulic Hose (Compact Diesel)
19	1	092-2000-00	Left Brake Assembly
20	1	092-2050-00	Right Brake Assembly

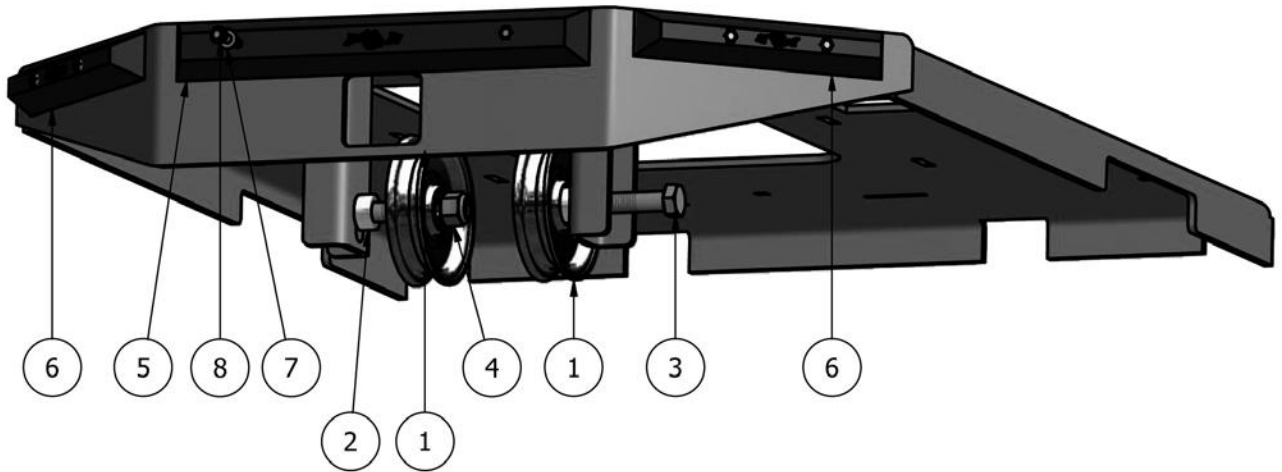

Parts List			
ITEM	QTY	PART NUMBER	DESCRIPTION
1	2	033-7025-00	5" V Idler Pulley
2	2	025-7020-00	5/8" x 1/2" Collar Spacer
3	2	018-6059-00	5/8" x 2 1/2" Bolt
4	2	013-7021-00	5/8" Nylock Nut
5	1	029-7037-00	14" Bumper
6	2	029-7038-00	8" Bumper
7	6	019-7040-00	1/4" Flat Washer
8	6	030-7039-00	1/4" x 1 1/2" Self Tapping Screw

Diesel Seat Frame

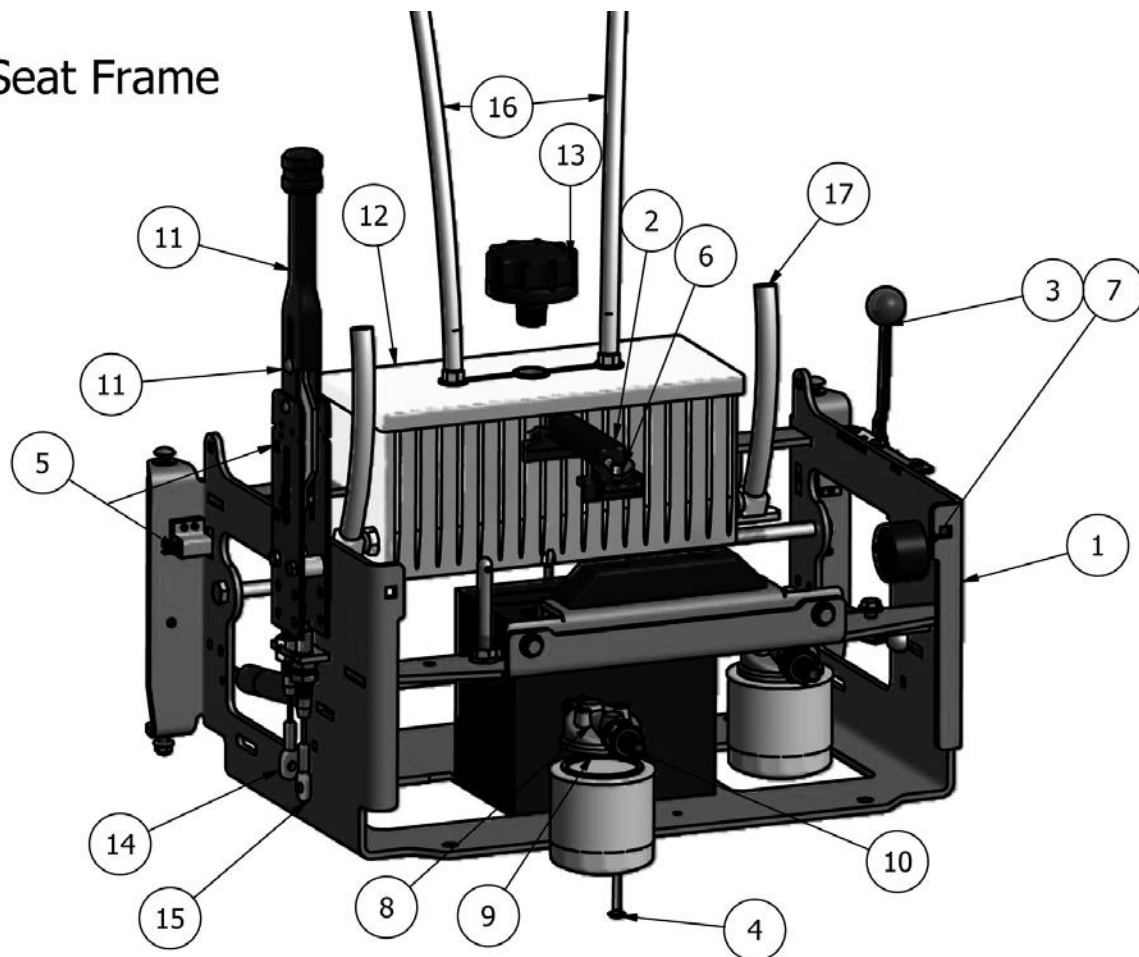

Parts List

ITEM	QTY	PART NUMBER	DESCRIPTION
1	1	080-6000-00	Seat Frame
2	1	043-8929-00	Battery Hold Down
3	1	055-8018-00	Throttle Lever Assembly
4	2	018-8051-00	9" Stove Bolt
5	2	077-8073-00	Switch
6	2	013-8051-00	1/4" Wing Nut
7	1	021-8059-00	buzzer
8	2	062-8013-00	Filter Head
9	2	063-8014-00	Hydraulic Filter
10	4	024-5050-00	Filter Head Fitting
11	1	069-8054-00	Hand Brake Assembly
12	1	067-2010-00	Aluminum Hydraulic Tank
13	1	066-8048-00	Hydraulic Tank Cap
14	1	064-8055-00	Brake Cable
15	1	064-8056-00	Long Brake Cable
16	2	051-8063-00	3/8" x 32" Clear Hose
17	2	051-8064-00	1/2" x 9 1/4" Braided Hose

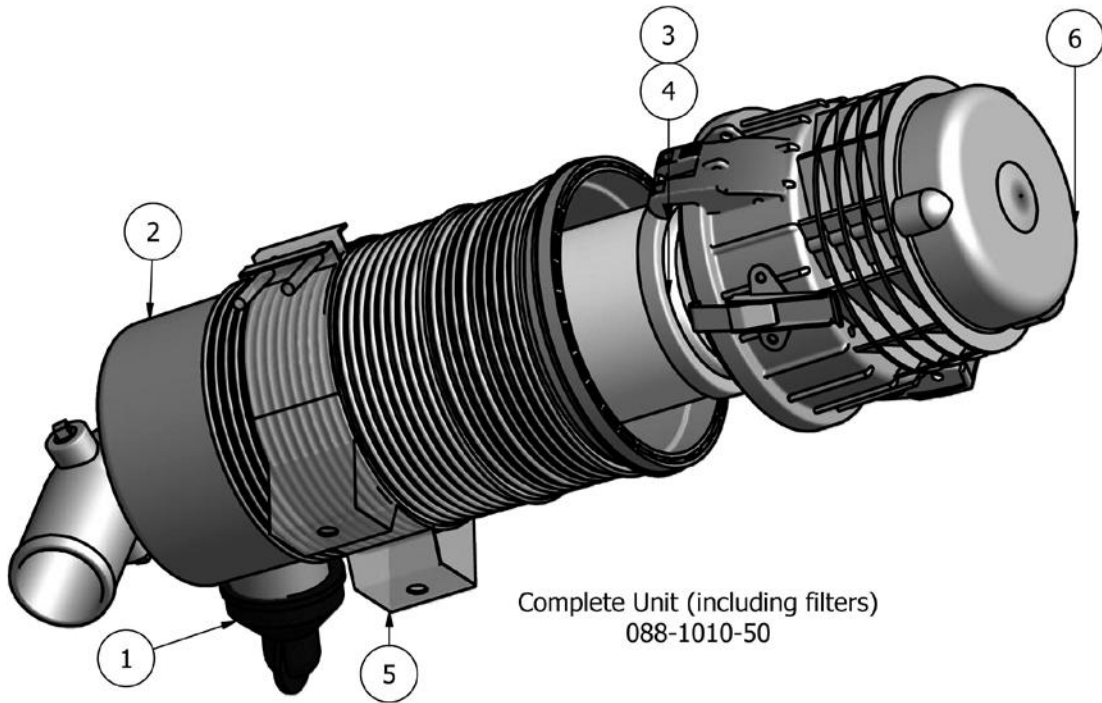

Complete Unit (including filters)
088-1010-50

Parts List			
ITEM	QTY	PART NUMBER	DESCRIPTION
1	1	088-1020-00	Debris Plug
2	1	088-1018-00	Canister Body
3	4	063-2060-00	Inner Filter
4	4	063-2050-00	Outer Filter
5	3	088-1019-00	Mounting Bracket
6	1	088-1017-00	Filter Cap
7	1	088-1010-50	Complete Unit

Diesel Pump Plate

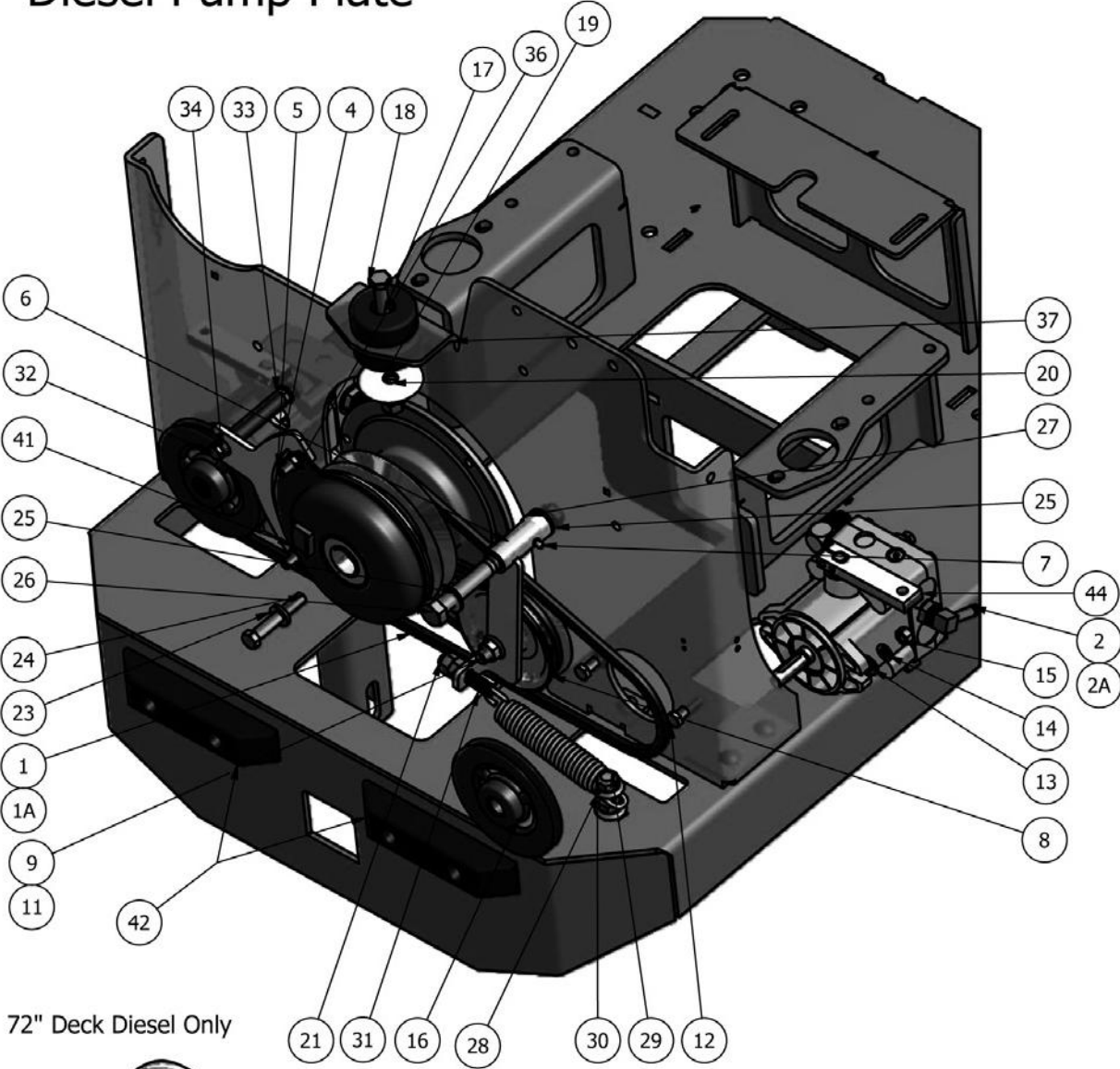

72" Deck Diesel Only

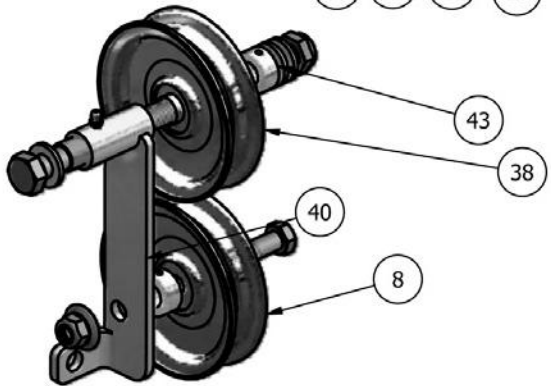



Diesel Pump Plate			
ITEM	QTY	PART NUMBER	DESCRIPTION
1	1	041-8411-00	Pump Belt 72" Deck
1A	1	041-5048-00	Pump Belt 60" Deck
2	1	050-5308-00	Hydraulic Pump Left
2A	1	050-5407-00	Hydraulic Pump Right
3	1	070-5040-00	Diesel Clutch
4	1	057-5910-10	Diesel PTO Engager Holder
5	8	018-5043-00	3/8" x 1 1/4" Carriage Bolt
6	1	039-5950-00	Pump Idler Bracket (60 Only)
7	1	024-6034-00	1/4" Drive-in Grease Fitting
8	1	033-6001-00	4 3/4" Idler Pulley
9	1	018-5049-00	1/2" x 2" Hex Bolt
10	2	032-6033-00	5/8" x 1 1/8" Brass Bushing
11	1	013-5300-00	1/2" Flange Nut
12	4	018-6012-00	3/8" x 1 1/4" Hex Bolt
13	4	019-5029-00	3/8" Flat Washer
14	4	019-5037-00	3/8" Lock Washer
15	4	013-6014-00	3/8" Hex Nut
16	2	033-5011-00	5" Pump Pulley
17	1	032-4000-00	Rubber Isolator
18	1	018-7016-00	1/2" x 3" Bolt
19	1	019-2040-00	1/2" Flat Washer
20	1	019-5007-00	1/2" Lock Washer
21	3	013-7018-00	1/2" Hex Nut
22	1	013-5301-00	5/8" Nylock (1/2 Jam)
23	1	019-8053-00	7/16" Lock Washer
24	1	018-5401-00	7/16" x 2 3/4" Fine Thread Bolt
25	2	019-6017-00	.635 ID Plastic Washer
26	1	018-5312-00	5/8" x 4 1/2" Hex Bolt
27	1	025-7036-00	1/2" Collar Spacer
28	1	034-5039-00	6" Pump Idler Spring
29	1	018-1050-00	1/2" x 2" Carriage Bolt
30	2	013-8050-00	1/2" Nylon Flange Nut-Orange
31	1	018-2004-00	1/2" x 2 1/2" All Thd Stud
32	1	018-2005-00	3/8" x 4 1/2" Bolt
33	2	013-5201-00	3/8" Flange Nut
34	1	051-8067-00	Rubber Spacer
36	2	013-5202-00	3/8" Nylock Flange Nut
37	1	026-8030-00	Pump Plate Diesel
38	1	033-4050-00	5" Idler Pulley
39	1	018-6016-00	5/8" x 5 1/2" Hex Bolt
40	1	039-5945-00	Diesel Pump Idler (72 Only)
41	1	070-2000-00	Clutch Pigtail
42	2	029-7038-00	8" Rubber Bumper
43	1	025-7020-00	5/8" Set Collar
44	2	031-5923-00	Pump Arm

Compact Diesel Pump Plate

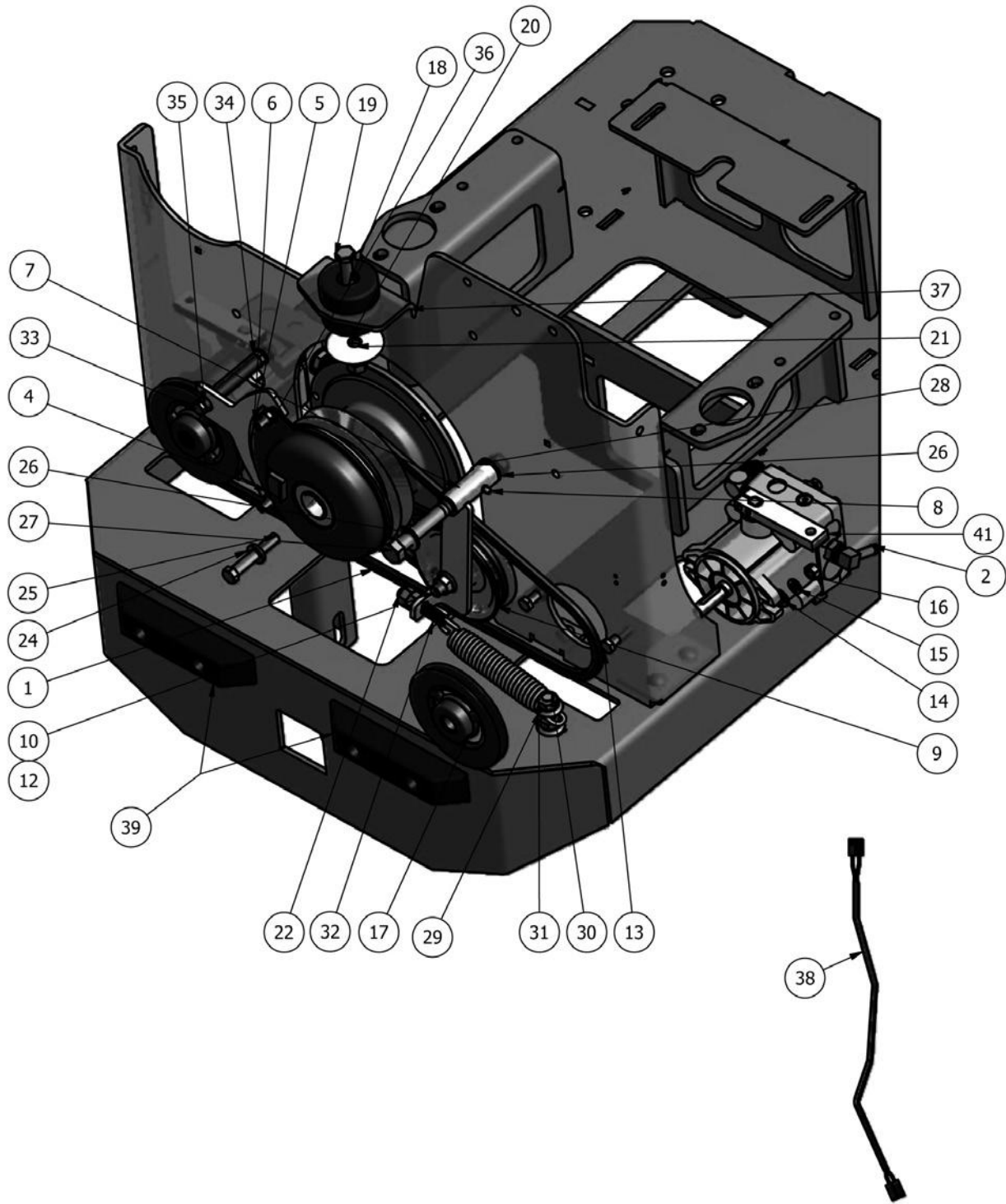



Compact Diesel Pump Plate			
ITEM	QTY	PART NUMBER	DESCRIPTION
1	1	041-5048-00	Pump Belt
2	1	050-5500-00	Hydraulic Pump with Fan and Cover Left
3	1	050-5501-00	Hydraulic Pump with Fan and Cover Right
4	1	070-5040-00	Diesel Clutch
5	1	057-5910-10	Diesel PTO Engager Holder
6	8	018-5043-00	3/8" x 1 1/4" Carriage Bolt
7	1	039-5950-00	Pump Idler Bracket (60 Only)
8	1	024-6034-00	1/4" Drive-in Grease Fitting
9	1	033-6001-00	4 3/4" Idler Pulley
10	1	018-5049-00	1/2" x 2" Hex Bolt
11	2	032-6033-00	5/8" x 1 1/8" Brass Bushing
12	1	013-5300-00	1/2" Flange Nut
13	4	018-6012-00	3/8" x 1 1/4" Hex Bolt
14	4	019-5029-00	3/8" Flat Washer
15	4	019-5037-00	3/8" Lock Washer
16	4	013-6014-00	3/8" Hex Nut
17	2	033-5011-00	5" Pump Pulley
18	1	032-4000-00	Rubber Isolator
19	1	018-7016-00	1/2" x 3" Bolt
20	1	019-2040-00	1/2" Flat Washer
21	1	019-5007-00	1/2" Lock Washer
22	3	013-7018-00	1/2" Hex Nut
23	1	013-5301-00	5/8" Nylock (1/2 Jam)
24	1	019-8053-00	7/16" Lock Washer
25	1	018-5401-00	7/16" x 2 3/4" Fine Thread Bolt
26	2	019-6017-00	.635 ID Plastic Washer
27	1	018-5312-00	5/8" x 4 1/2" Hex Bolt
28	1	025-7036-00	1/2" Collar Spacer
29	1	034-5039-00	6" Pump Idler Spring
30	1	018-1050-00	1/2" x 2" Carriage Bolt
31	2	013-8050-00	1/2" Nylon Flange Nut-Orange
32	1	018-2004-00	1/2" x 2 1/2" All Thd Stud
33	1	018-2005-00	3/8" x 4 1/2" Bolt
34	2	013-5201-00	3/8" Flange Nut
35	1	051-8067-00	Rubber Spacer
36	2	013-5202-00	3/8" Nylock Flange Nut
37	1	026-8030-00	Pump Plate Diesel
38	1	070-2000-00	Clutch Pigtail
39	2	029-7038-00	8" Rubber Bumper
40	1	025-7020-00	5/8" Set Collar
41	2	031-5923-00	Pump Arm

35hp 4-Cylinder

Diesel Engine

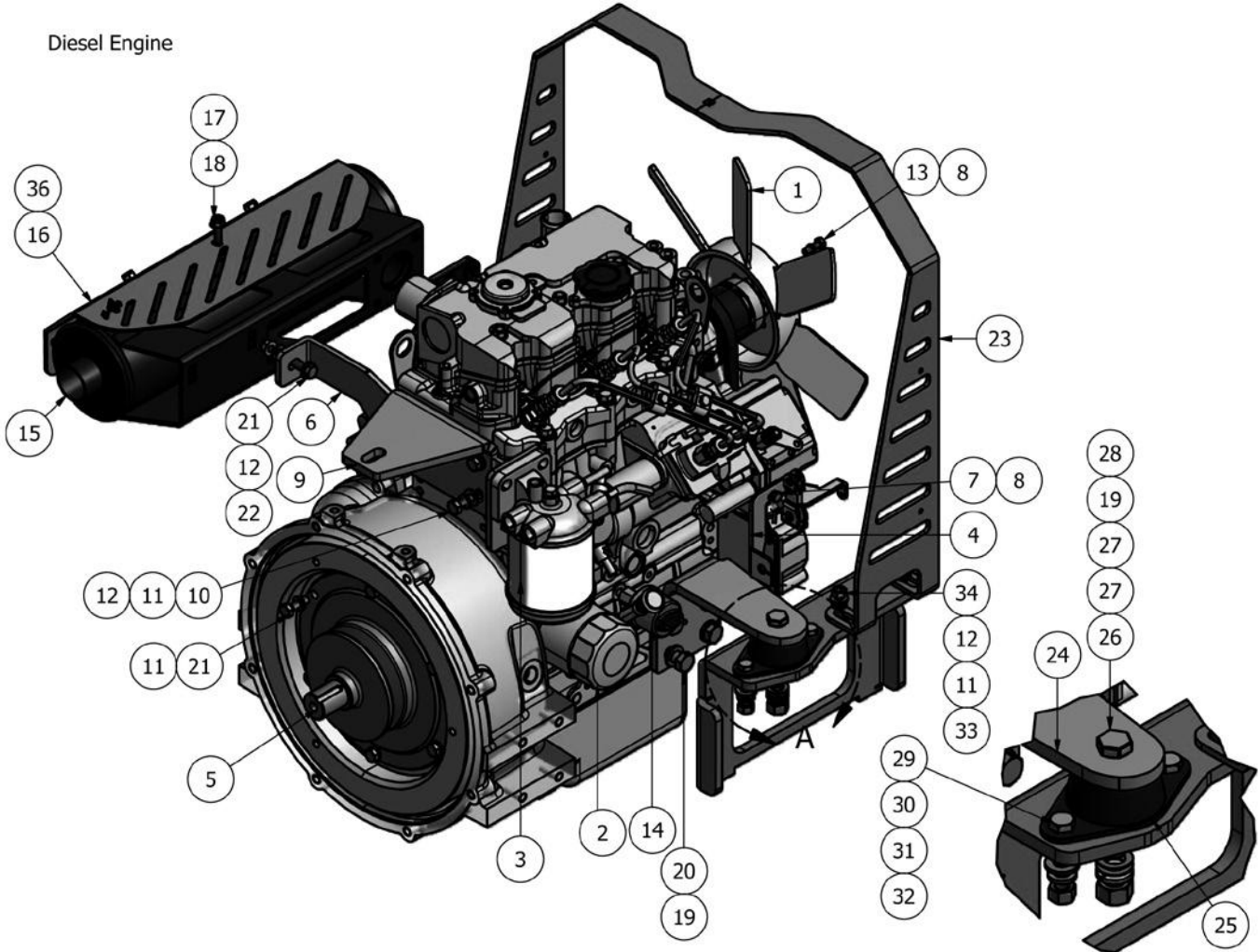

DETAIL A



Parts List			
ITEM	QTY	PART NUMBER	DESCRIPTION
1	1	015-6050-00	Diesel Fan
2	1	063-2010-00	Cat Oil Filter
3	1	063-2011-00	Fuel Filter
4	1	039-1010-00	Diesel Throttle Bracket (4 Tier)
5	1	017-3000-00	Stub Shaft
6	1	039-1020-00	Diesel Muffler Hanger Bracket
7	2	018-2002-00	6 mm x 10 mm Hex Bolt
8	6	019-4008-00	1/4" Lock Washer
9	1	201-8005-00	Rear Motor Mount for Diesel
10	2	018-2010-00	10-32 x 3/8 Button Head
11	14	019-8051-00	5/16" Lock Washer
12	10	019-8044-00	5/16" Flat Washer
13	4	018-2000-00	6mm x 20mm Bolt
14	1	086-5001-00	Oil Pressure Guage with Sender
15	1	015-0005-00	Diesel Muffler
16	1	043-1010-00	Diesel Muffler Guard (28hp)
17	3	030-8000-00	1/4" x 3/4" Set Screw
18	3	013-9001-00	1/4" Flange Nut
19	10	019-5007-00	1/2" Lock Washer
20	8	018-6022-00	12mm Bolt- Diesel
21	7	018-2007-00	5/16" x 1" Bolt
22	1	013-8049-00	5/16-18 Nylock Flange Nut
23	1	201-8001-00	Hood Holder Diesel
24	2	201-8008-00	Diesel Motor Side Support (Right)
25	2	032-4050-00	Rubber Isolator
26	2	018-7016-00	1/2" x 3" Hex Bolt
27	4	019-5010-00	1/2" Brass Washer
28	2	013-7018-00	1/2" Hex Nut
29	4	018-6049-00	3/8" x 1" Hex Bolt
30	4	019-5029-00	3/8" Flat Washer
31	4	019-5037-00	3/8" Lock Washer
32	4	013-6014-00	3/8" Hex Nut
33	4	018-5025-00	5/16" x 1 1/4" Hex Bolt
34	4	013-8043-00	5/16" Nut
35	1	201-8009-00	Diesel Motor Side Support (Left)
36	1	043-1000-00	Diesel Muffler guard 35hp

28hp 3-Cylinder

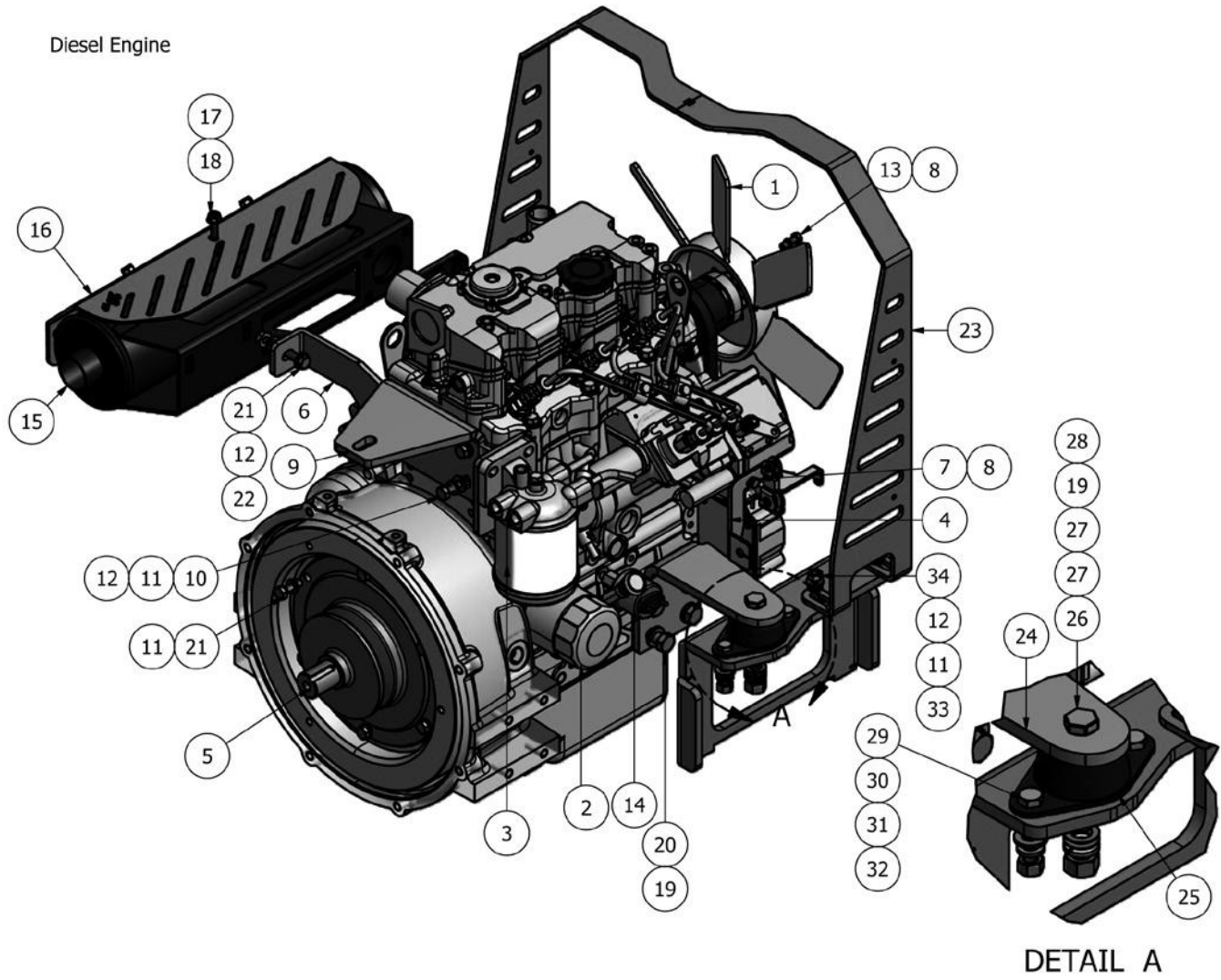



Parts List			
ITEM	QTY	PART NUMBER	DESCRIPTION
1	1	015-6050-00	Diesel Fan
2	1	063-2010-00	Cat Oil Filter
3	1	063-2011-00	Fuel Filter
4	1	039-1010-00	Diesel Throttle Bracket (4 Tier)
5	1	017-3000-00	Stub Shaft
6	1	039-1020-00	Diesel Muffler Hanger Bracket
7	2	018-2002-00	6 mm x 10 mm Hex Bolt
8	6	019-4008-00	1/4" Lock Washer
9	1	201-8005-00	Rear Motor Mount for Diesel
10	2	018-2010-00	10-32 x 3/8 Button Head
11	14	019-8051-00	5/16" Lock Washer
12	10	019-8044-00	5/16" Flat Washer
13	4	018-2000-00	6mm x 20mm Bolt
14	1	086-5001-00	Oil Pressure Guage with Sender
15	1	015-0005-00	Diesel Muffler
16	1	043-1010-00	Diesel Muffler Guard (28hp)
17	3	030-8000-00	1/4" x 3/4" Set Screw
18	3	013-9001-00	1/4" Flange Nut
19	10	019-5007-00	1/2" Lock Washer
20	8	018-6022-00	12mm Bolt- Diesel
21	7	018-2007-00	5/16" x 1" Bolt
22	1	013-8049-00	5/16-18 Nylock Flange Nut
23	1	201-8001-00	Hood Holder Diesel
24	2	201-8008-00	Diesel Motor Side Support (Right)
25	2	032-4050-00	Rubber Isolator
26	2	018-7016-00	1/2" x 3" Hex Bolt
27	4	019-5010-00	1/2" Brass Washer
28	2	013-7018-00	1/2" Hex Nut
29	4	018-6049-00	3/8" x 1" Hex Bolt
30	4	019-5029-00	3/8" Flat Washer
31	4	019-5037-00	3/8" Lock Washer
32	4	013-6014-00	3/8" Hex Nut
33	4	018-5025-00	5/16" x 1 1/4" Hex Bolt
34	4	013-8043-00	5/16" Nut
35	1	201-8009-00	Diesel Motor Side Support (Left)

Deck Spindle

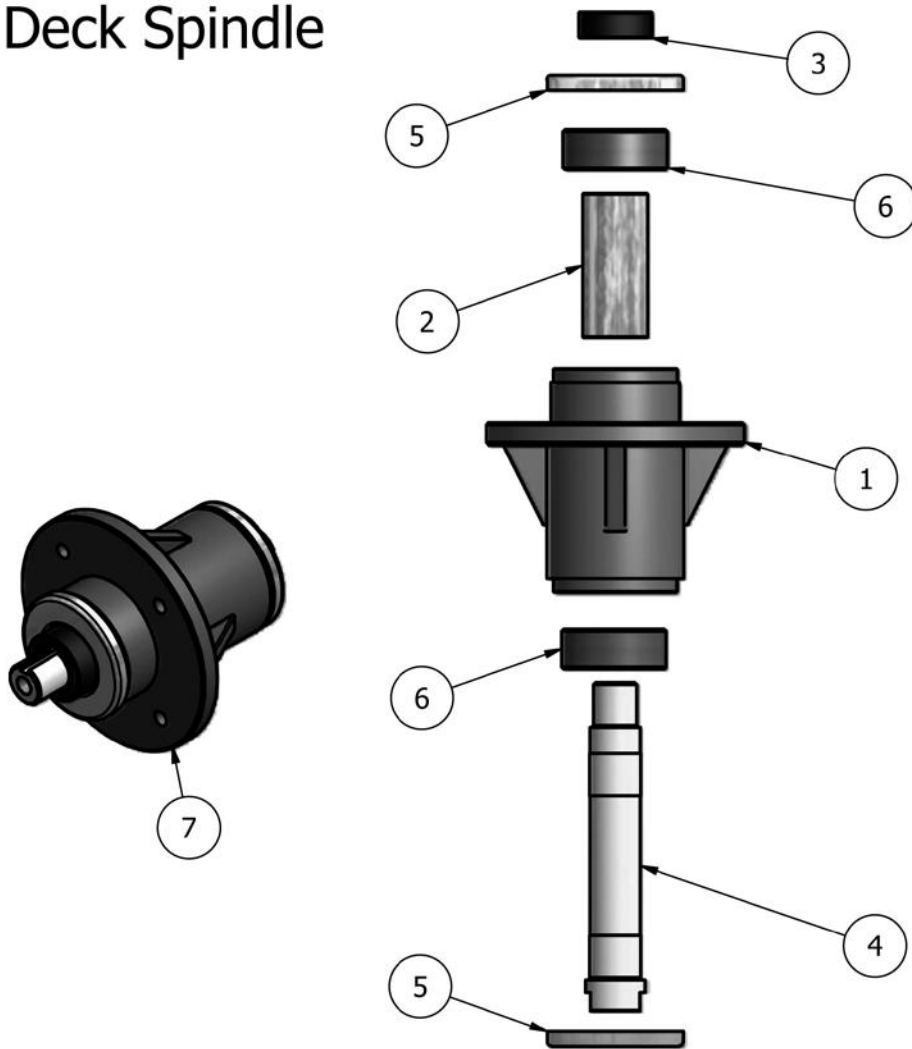

Parts List			
ITEM	QTY	PART NUMBER	DESCRIPTION
1	1	037-8005-00	Spindle Housing
2	1	037-8003-00	Spindle Spacer
3	1	037-9050-00	Spindle Collar
4	1	037-6019-00	Spindle Shaft
5	2	037-8002-00	Bearing Cover
6	2	037-8001-00	Bearing
7	1	037-8000-00	Complete Spindle Assembly



Diesel Hydraulic Cooler

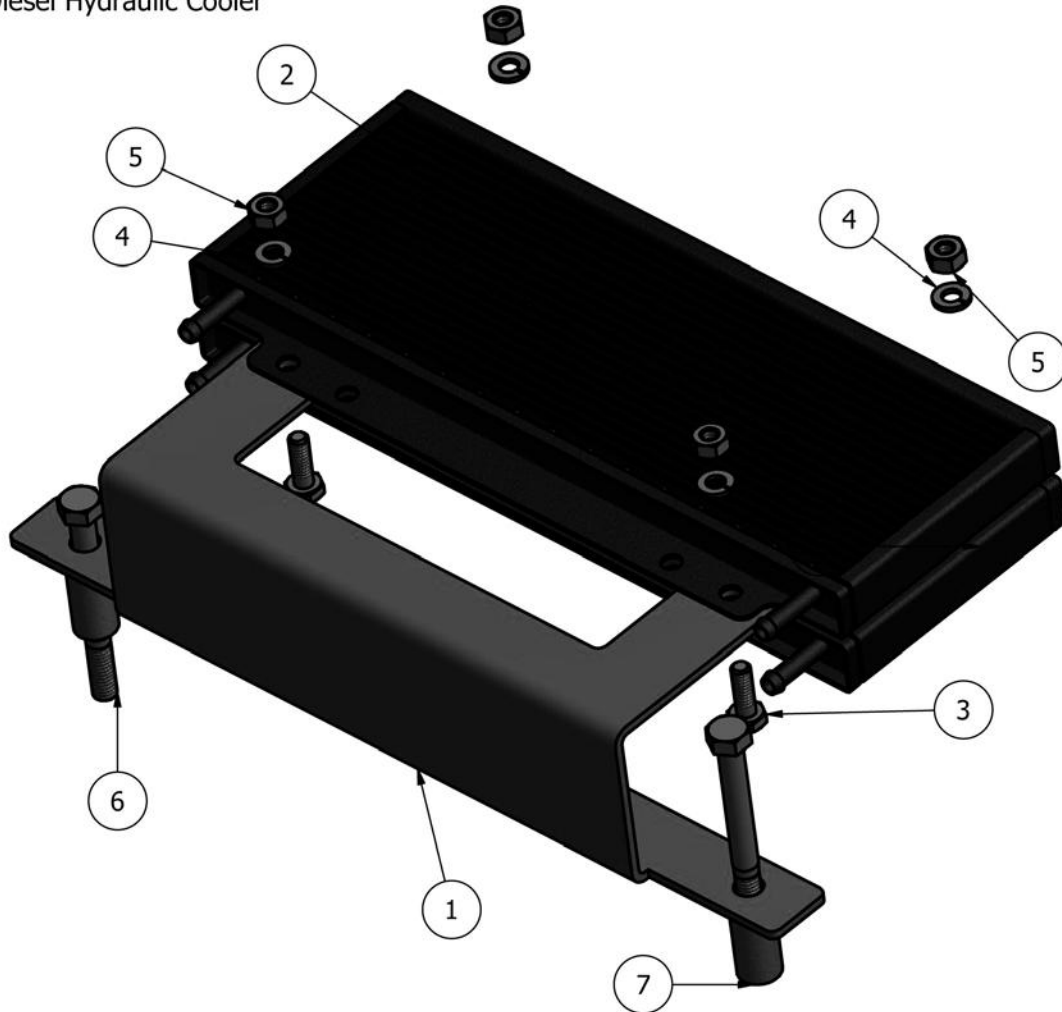

Parts List			
ITEM	QTY	PART NUMBER	DESCRIPTION
1	1	057-5950-00	Cooler Holder
2	2	061-8012-00	Hydraulic Cooler
3	4	018-8052-00	1/4" x 3/4" Hex Bolt
4	4	019-4008-00	1/4" Lock Washer
5	4	013-8039-00	1/4" Hex Nut
6	2	018-4701-00	5/16" x 3" Bolt (35hp)
7	2	025-8000-00	Cooler Holder Spacer (35hp)

Radiator

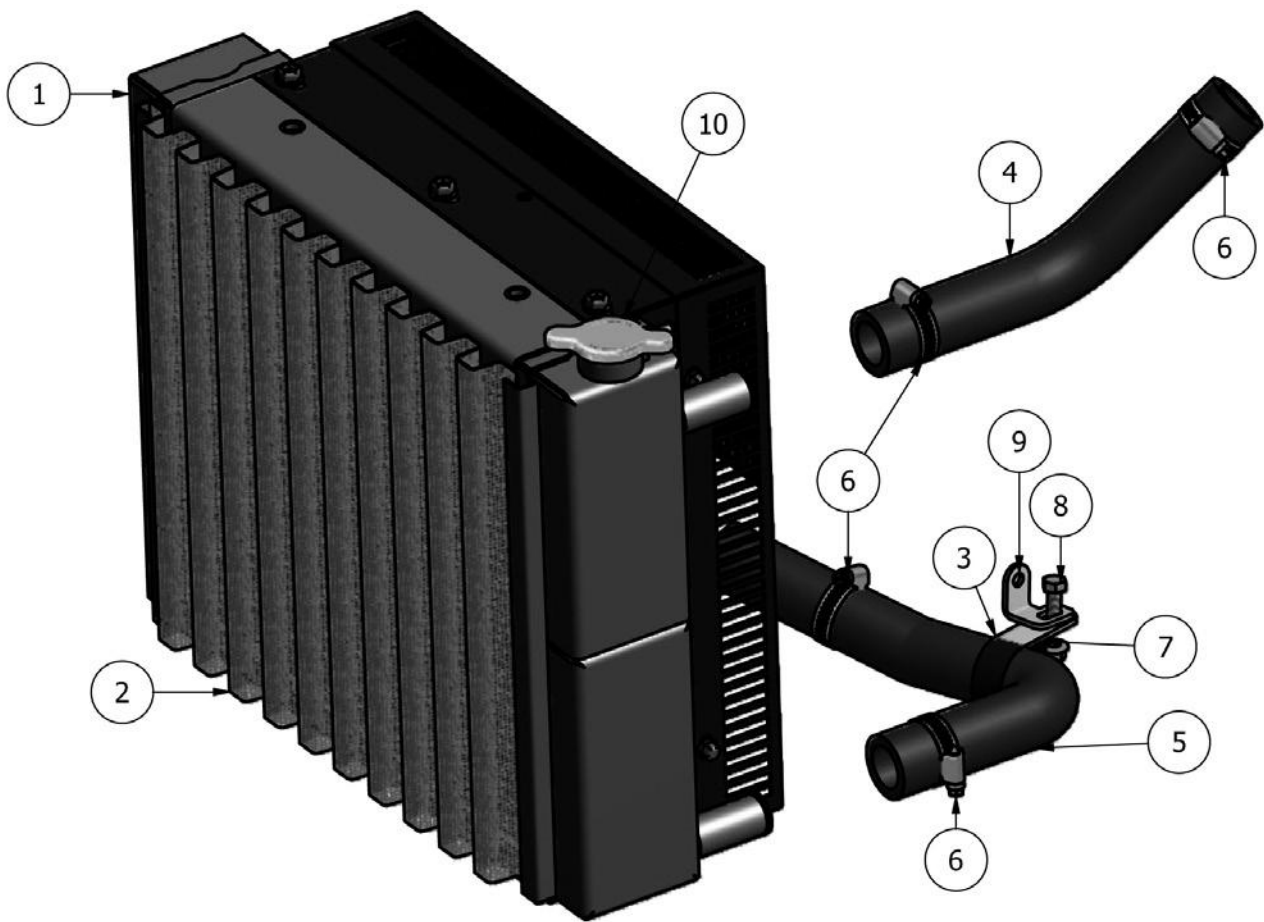



Parts List			
ITEM	QTY	PART NUMBER	DESCRIPTION
1	1	061-5000-00	Radiator- 28hp & 35hp Diesel Models
2	1	094-5088-00	Radiator Screen-Diesel
3	1	072-8090-00	Diesel Clamp 1 3/4" Vinyl
4	1	051-3000-00	Top Radiator Hose for Diesel
5	1	051-3001-00	Bottom Radiator Hose for Diesel
6	4	072-2003-00	1 1/8" Hose Clamp
7	1	013-9002-00	5/16" Flange Nut
8	1	018-6083-00	5/16" x 3/4" Hex Bolt
9	1	039-1015-00	Diesel Radiator Hose Clamp Bracket
10	1	015-0104-00	Diesel Radiator Cap

60" Deck

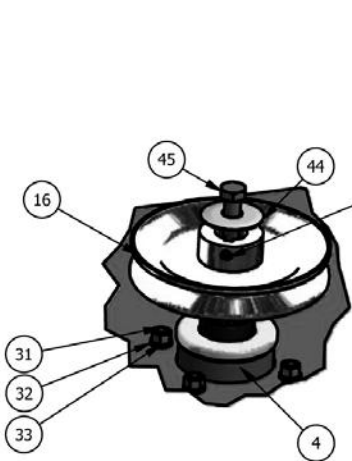
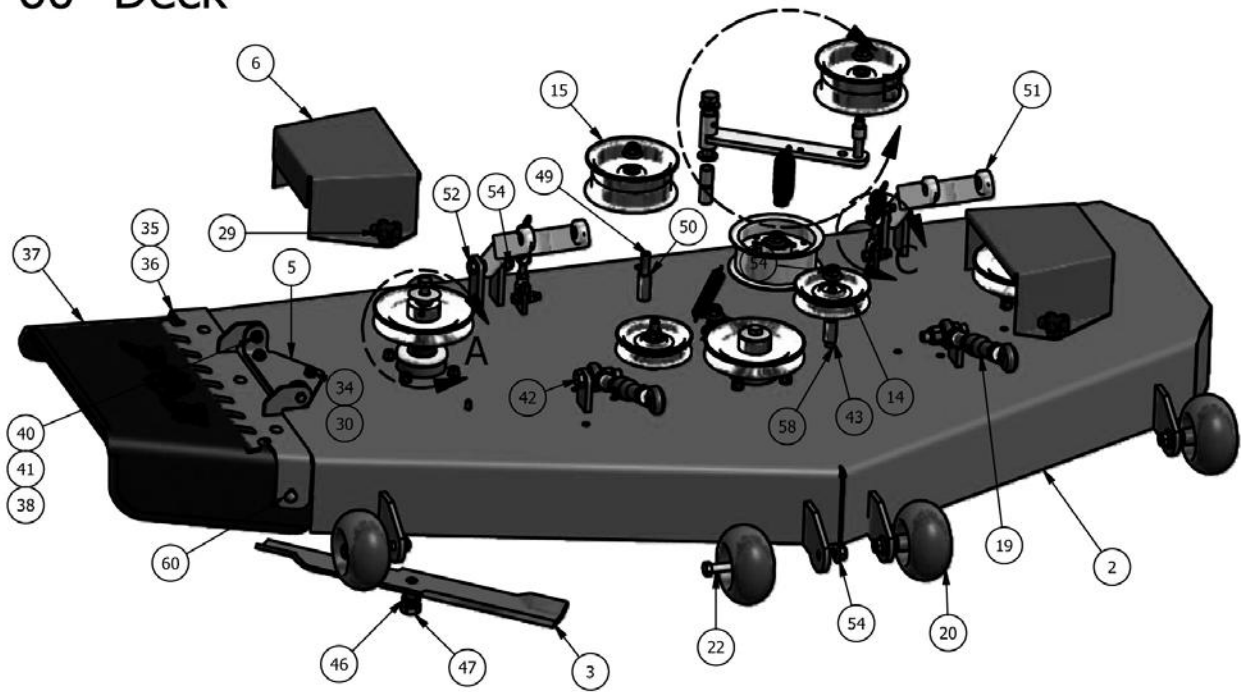

DETAIL A

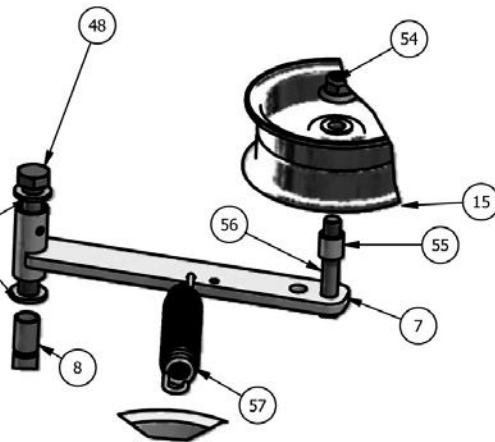

DETAIL B

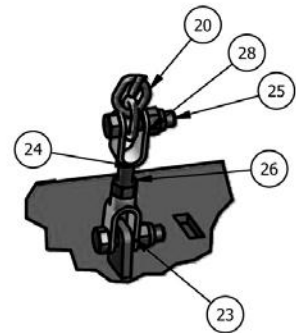

DETAIL C

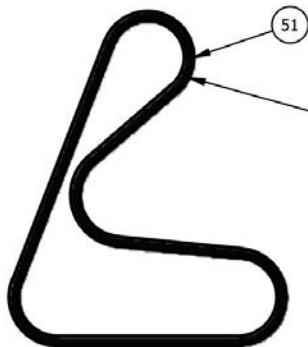

60" Deck Belt

041-2375-00 35 HP Diedel (60"Deck)



60" Deck Parts List			
ITEM	QTY	PART NUMBER	DESCRIPTION
1	1	060-5403-98	60" Deck Complete Assembly with Spindles
2	1	060-5403-00	60" Deck Shell Only
3	3	038-6060-00	60 Inch Fusion Blade
4	3	037-8000-00	Double Bearing Spindle Assembly
5	1	206-6017-00	Discharge Chute Hanger
6	2	014-6010-00	Plastic Pulley Cover
7	1	039-6945-00	Deck Idler
8	2	032-6033-00	5/8 x 1 1/8" Brass Bushing
9	1	018-7016-00	1/2" x 3" Hex Bolt
11	1	025-5025-00	1" Collar Spacer
12	1	013-8050-00	1/2-13 Nylon Flange Nut-Orange
14	2	033-6001-00	4 3/4" Idler Pulley
15	2	033-5001-00	5 3/4" Deck Idler Pulley
16	3	033-6004-00	6 1/4" Drive Pulley
17	1	030-0050-00	5/16" Set Screw
18	2	019-6017-00	.635 ID Plastic Washer
19	2	048-6056-00	Turnbuckle (Top Link)
20	6	022-5234-00	Anti-Scalp Rollers
21	6	022-5234-98	Anti-Scalp Rollers Complete Assembly
22	6	018-5019-00	1/2" x 4" Bolt (Grade 8)
23	2	046-6044-00	Female Yoke
24	2	046-6048-00	Male Yoke
25	4	018-6012-00	3/8" x 1 1/2" Hex Bolt
26	2	013-6014-00	3/8" Hex Nut
27	2	047-6048-98	4" Chain Assembly Diesel
28	4	013-5041-00	3/8 Nylock Nut
29	4	045-6043-00	5/16" Knob
30	3	018-5250-00	3/8" x 3/4" Hex Bolt
31	12	018-5040-00	3/8" x 1 1/4" Hex Bolt
32	12	019-5037-00	3/8" Lock Washer
33	12	013-6014-00	3/8" Hex Nut
34	3	013-5201-00	3/8" Flange Nut
35	1	039-4863-00	60" Lower Hanger
36	1	039-4864-00	60" Discharge Chute Upper Hanger Plate
37	1	210-6005-00	Rubber Discharge Chute (Rubber Only)
38	2	019-6042-00	.360 ID Plastic Washer
39	1	210-6004-00	Complete Assembly Rubber Discharge Chute
40	2	018-5015-00	5/16" x 1" Hex Bolt
41	7	013-8049-00	5/16" Nylock Flange Nut
42	2	018-6059-00	5/8" x 2 1/2" Hex Bolt
43	2	025-5338-00	Pulley Spacer
44	3	019-6019-00	Cup Washer
45	3	018-5600-00	1/2" x 1 1/2" Hex Bolt
46	3	019-4807-00	5/8" Lock Washer
47	3	018-6020-00	5/8-18 x 1 1/2 GR 8 Hex Bolt
48	1	018-5311-00	5/8" x 4" Hex Bolt
49	1	018-6054-00	1/2-13 x 3 1/2 GR 5 Hex Bolt
50	1	025-5339-00	1 3/4" Pulley Spacer
51	2	031-6010-00	Deck Arm Assembly
52	2	018-6036-00	1/2" x 2 1/2" Hex Bolt
53	2	013-5300-00	1/2" Flange Nut
54	14	013-8050-00	1/2-13 Nylon Flange Nut-Orange
55	1	025-5203-00	3/4 OD x 1/2 ID x 3\4 Length
56	1	018-7016-00	1/2 x 3" Bolt
57	1	034-2009-00	Deck Idler Spring
58	2	018-2018-00	1/2 x 3 1/2 Flange Bolt Grade 8
51	1	041-2375-00	Deck Belt 60" Deck
60	5	018-4703-00	5/16" x 1 1/4" Carriage Bolt

72" Deck

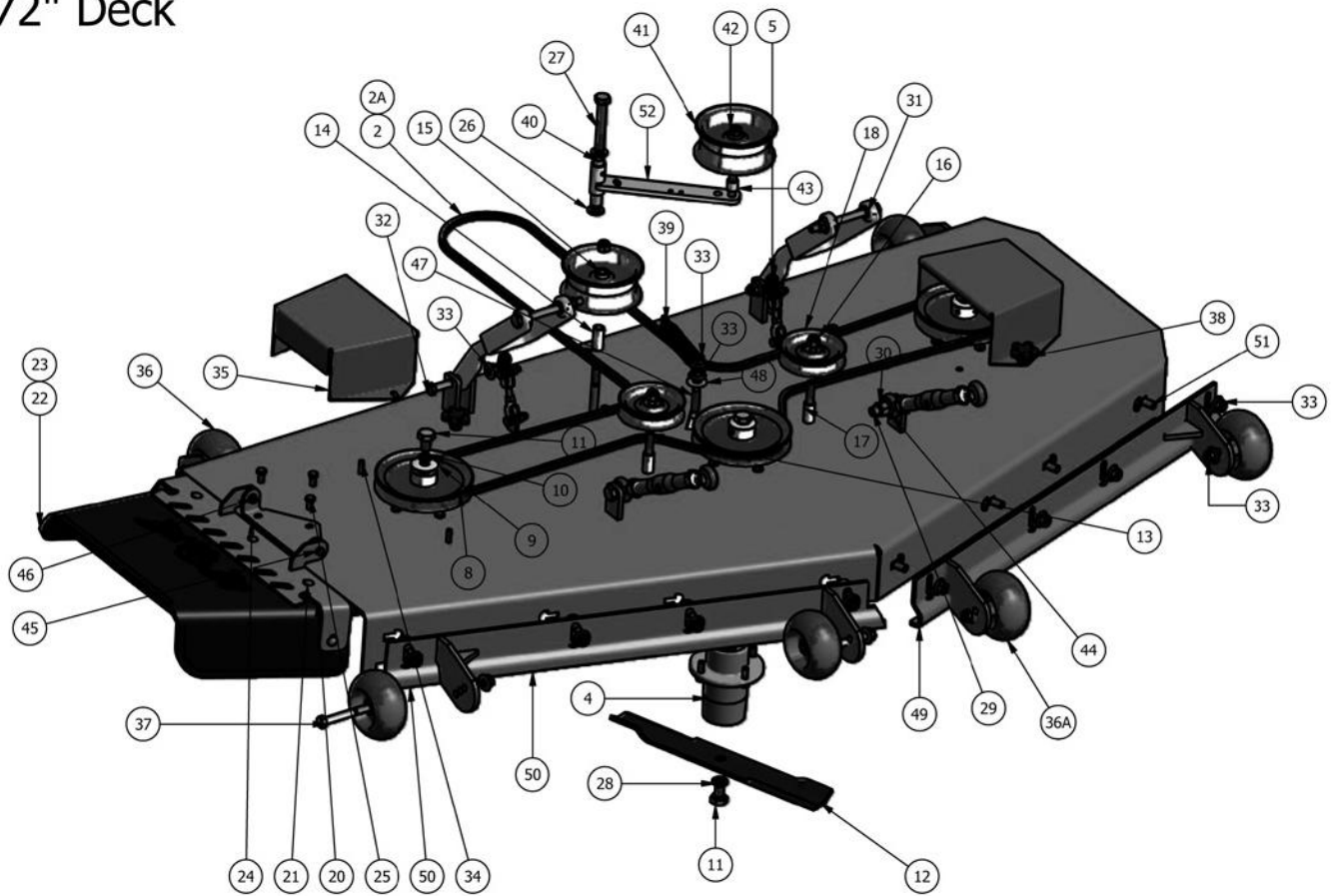



72" Deck			
ITEM	QTY	PART NUMBER	DESCRIPTION
1	1	060-7201-00	72" Deck Shell
1A	1	060-7201-98	Complete 72" Deck
2	1	041-2525-00	72" Deck Belt (Diesel)
3	2	046-6048-98	4 Link Chain Assembly
4	3	037-8000-00	Double Bearing Spindle
5	12	018-5040-00	3/8" x 1 1/4" Hex Bolt
6	12	019-5037-00	3/8" Lock Washer
7	12	013-6014-00	3/8-16 Hex Nuts Zinc
8	3	033-7203-00	7" Deck Pulley
9	3	019-6019-00	Cup Washer
9A	1	030-0050-00	5/16" Set Screw
10	3	019-5007-00	1/2" Lock Washer
11	6	018-6020-00	5/8" x 1 1/2" Hex Bolt Grade 8
12	3	038-7230-00	72" Fusion High Lift Blade
13	2	018-2018-00	1/2" x 3 1/2" Grade 8 Bolt
14	1	025-5339-00	1 3/4" Pulley Spacer
15	1	033-5001-00	5 3/4" Deck Idler Pulley
16	3	013-5051-00	1/2" Nylock Nut
17	2	025-5338-00	1 1/2" Diesel Pulley Spacer
18	2	033-6001-00	4 3/4" Idler Pulley
19	1	039-4863-00	72" Lower Hanger
20	1	039-4864-10	72" Discharge Chute Upper Hanger Plate
21	5	018-4703-00	5/16" x 1 1/4" Carriage Bolt
22	1	210-6005-00	Rubber Discharge Chute
23	1	210-6006-00	72" Complete Chute Assembly
24	1	206-6017-00	Discharge Chute Hanger (deck mounted)
25	3	018-5250-00	3/8" x 3/4" Hex Bolt
26	2	019-6017-00	.635 ID Plastic Washer
27	1	018-5311-00	5/8" x 4" Hex Bolt
28	3	019-4807-00	5/8" Lock Washer
29	2	018-6059-00	5/8" x 2 1/2" Hex Bolt
30	2	013-7021-00	5/8 Std NC Nylock Nut
31	2	031-6010-00	Deck Arm Assembly
32	2	018-6036-00	1/2" x 2 1/2" Hex Bolt
33	2	013-8050-00	1/2 Nylon Flange Nut-Orange
34	4	018-2006-00	5/16" x 1 1/4" Hex Bolt
35	2	014-7204-00	72" Pulley Cover
36	6	022-5234-00	Anti-Scalp Rollers
36A	1	0225234-98	Complete Roller Assembly
37	7	018-5019-00	1/2" x 4" Bolt (Grade 8)
38	4	045-6043-00	5/16" Knob
39	1	034-2009-00	Deck Idler Spring
40	2	032-6033-00	5/8 x 1 1/8 Brass Bushing
41	1	033-5001-00	5 3/4" Deck Idler Pulley
42	1	013-8050-00	1/2-13 Nylon Flange Nut-Orange
43	1	025-5203-00	3/4 OD x 1/2 ID x 3\4 Length
44	2	048-6056-00	Turnbuckle (Top Link)
45	2	018-5015-00	5/16" x 1" Hex Bolt
46	7	013-8049-00	5/16" Nylock Flange Nut
47	1	018-1050-00	1/2 x 2" Carriage Bolt
48	1	019-2040-00	1/2" Flat Washer
49	1	060-7210-00	72" Deck Adjustable Front (Left)
50	1	060-7211-00	72" Deck Adjustable Front (Right)
51	8	018-3003-00	1/2" x 1 1/4" Carriage Bolt
52	1	039-6945-00	Deck Idler

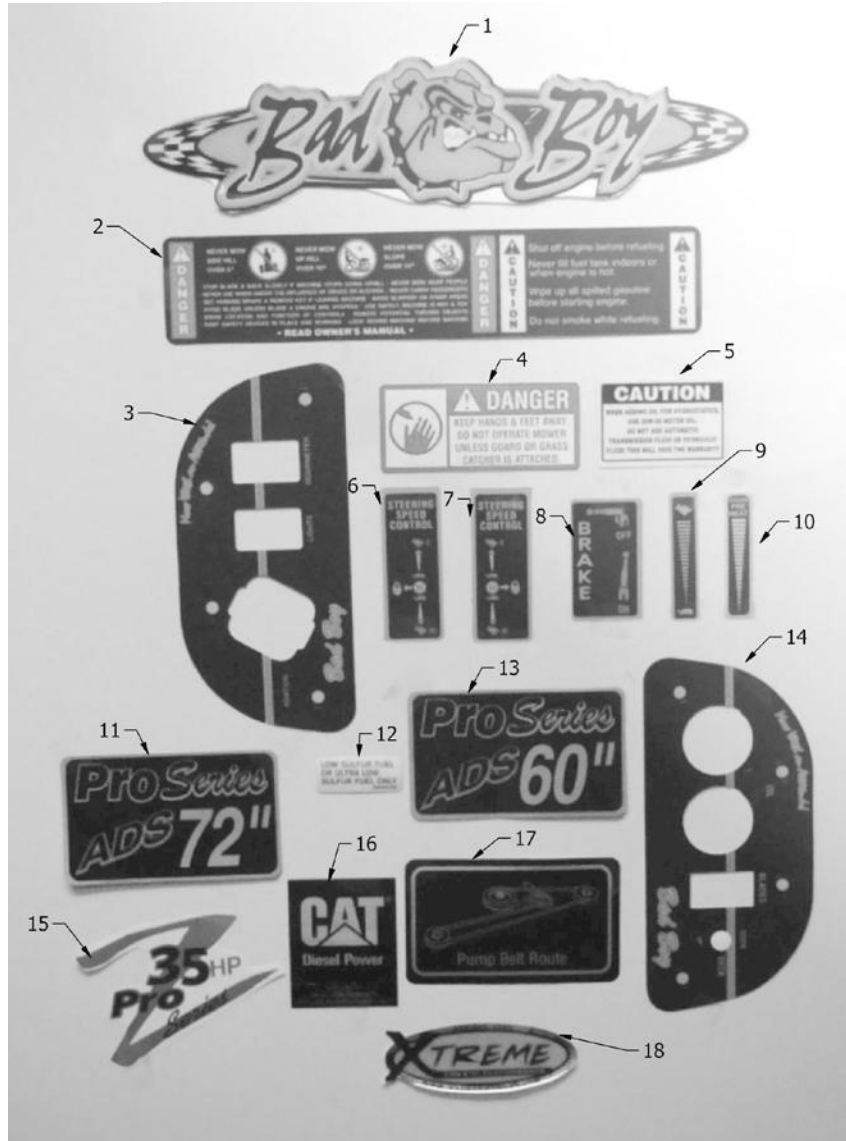

Parts List			
ITEM	QTY	PART NUMBER	DESCRIPTION
1	1	091-4000-00	Domed Label
2	1	091-3300-00	Lexan Caution Decal
3	1	091-5505-00	Instrument Panel Decal Right
4	1	091-3012-00	Danger Decal
5	1	091-3300-00	Lexan Caution Decal
6	1	091-3304-00	Lexan Right Steering Speed Control Decal
7	1	091-3307-00	Lexan Left Steering Speed Control Decal
8	1	091-3302-00	Lexan Brake Decal
9	1	091-3301-00	Lexan Throttle Decal
10	1	091-5500-00	Preheat Decal for Diesel
11	1	091-3019-00	72 deck Decal ADS
12	1	091-2050-00	Low Sulfur
13	1	091-3018-00	60 Deck Decal
14	1	091-5506-00	Instrument Panel deck Left
15	1	091-5403-00	35hp Z-Pro Decal
16	1	091-5402-00	Cat Power
17	1	091-3017-00	Pump Belt Route
18	1	091-2000-00	X-Treme Decal

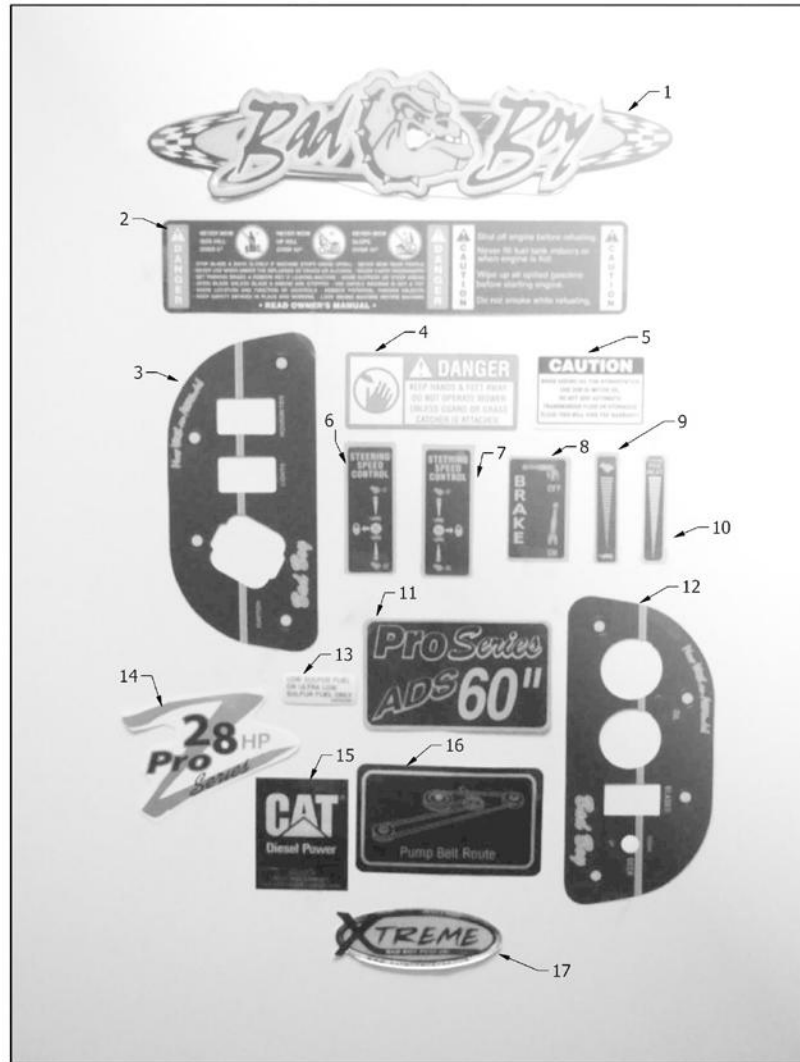

Parts List			
ITEM	QTY	PART NUMBER	DESCRIPTION
1	1	091-4000-00	Domed Label
2	1	091-3300-00	Lexan Caution Decal
3	1	091-5505-00	Diesel Instrument Panel Decal Right
4	1	091-3012-00	Danger Decal
5	1	091-3300-00	Lexan Caution Decal
6	1	091-3304-00	Lexan Right Steering Speed Control Decal
7	1	091-3307-00	Lexan Left Steering Speed Control Decal
8	1	091-3302-00	Lexan Brake Decal
9	1	091-3301-00	Lexan Throttle Decal
10	1	091-5500-00	Preheat Decal for Diesel
11	1	091-3018-00	60 Deck Decal ADS
12	1	091-5506-00	Diesel Instrument Panel Decal- Left
13	1	091-2050-00	Low Sulfur Decal
14	1	091-6000-00	Z28 Mini Decal - Hood - Diesel Models
15	1	091-5402-00	Cat Power
16	1	091-3017-00	Pump Belt Route
17	1	091-2000-00	x-Treme Diesel decal



NOTES: _____

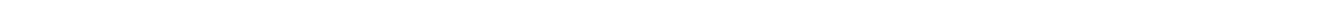
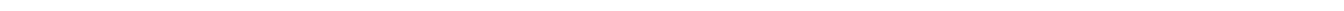
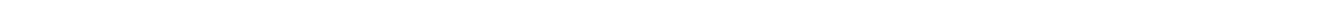



NOTES: _____

2011 LIMITED WARRANTY

FOR

BAD BOY COMMERCIAL MOWER

(AOS, CZT, DIESEL, LIGHTNING, OUTLAW, and PUP SERIES)

1. WHAT THIS WARRANTY COVERS, AND FOR HOW LONG:

Bad Boy, Inc. will, at its option, repair or replace, without charge, any part covered by the warranty which is found to be defective in material and/or workmanship within one (1) year* after date of sale to the original retail purchaser unless the product is used for rental purposes, in which case this warranty is limited to ninety (90) days.

The hydrostatic drive components, deck spindle assemblies, and the PTO clutch will be warranted for two full years from the date of sale to the original retail purchaser against defects in materials and workmanship. Labor required to repair or replace components of the hydrostatic drive system, deck spindle assemblies, or the PTO clutch will be covered by Bad Boy, Inc. for the first year, and at the unit owner's expense during the second year from the original purchase date.

The leading edge of the deck shell will be warranted for the entire lifetime of the machine to the original purchaser against defects in materials and workmanship. Labor required to repair or replace the leading edge of the deck shell will be covered by Bad Boy, Inc for the first year and at the unit owner's expense during the balance of the lifetime of the machine.

The Bad Boy ZT Series, featuring the Integrated Zero Turn Transaxle, used commercially will carry the shorter of a one year or 200 hour warranty, parts only. Labor on a Bad Boy ZT Series machine used commercially will not be covered by Bad Boy Inc, and will be the unit owner's responsibility.

Belts are warranted for a period of ninety (90) days against materials or workmanship defects.

At Bad Boy, Inc.'s request, customer will make the defective part available for inspection by Bad Boy, Inc. and/or return the defective part to Bad Boy, Inc., transportation charges prepaid.

Labor required to repair or replace warranted components will be covered for 1 year from the original purchase date, regardless of how much longer the part may be warranted.

2. WHAT THIS WARRANTY DOES NOT COVER:

A. This warranty does not cover defects caused by depreciation or damage caused by normal wear, accidents, improper maintenance, improper use or abuse of the product, alterations, or failure to follow the instruction contained in the Owner's Manual for operation and maintenance.

B. The customer shall pay any charges for making service calls and/or for transporting the mower to and from the place where the inspection and/or warranty work is performed.

Bad Boy Inc will not be responsible for the pickup and delivery of a machine for warranty purposes.

C. Engines are warranted separately by their respective manufacturer. The available warranties covering this item are furnished with each mower. Bad Boy, Inc. does not assume any warranty obligation, liability or modification for this item, which is covered exclusively by the stated warranty of the respective manufacturers.

D. Tires, blades, deck anti-scalping wheels and hoses are considered to be consumable wear items and are therefore not warranted.

E. Batteries are warranted for six months (free replacement) from the retail purchase date against materials or workmanship defects. The battery warranty must be obtained through the battery manufacturer.

3. HOW TO OBTAIN SERVICE UNDER THIS WARRANTY:

A. Warranty service can be arranged by contacting the dealer where you purchased the mower or by contacting Bad Boy, Inc. Proof of the date of purchase may be required to verify warranty coverage.

B. Warranty claims will not be reviewed or paid unless the warranty registration card is received by Bad Boy, Inc. within 30 days of the retail purchase date.

4. WARRANTY LIMITATION:

A. THERE IS NO OTHER EXPRESS WARRANTY. ANY WARRANTY THAT MAY BE IMPLIED FROM THIS PURCHASE INCLUDING MERCHANTABILITY AND FITNESS FOR A PARTICULAR PURPOSE IS HEREBY LIMITED TO THE DURATION OF THIS WARRANTY AND TO THE EXTENT PERMITTED BY LAW ANY AND ALL IMPLIED WARRANTIES ARE EXCLUDED. Some states do not allow limitations on how long an implied warranty lasts, so the above limitations may not apply to you.

B. BAD BOY, INC. WILL NOT BE LIABLE FOR ANY INCIDENTAL, CONSEQUENTIAL, OR SPECIAL DAMAGES AND/OR EXPENSES IN CONNECTION WITH THE PURCHASE OR USE OF THE MOWER. Some states do not allow the exclusion or limitation of incidental or consequential damages, so the above limitation(s) or exclusion(s) may not apply to you.

C. Only the warranty expressed in this limited warranty shall apply and no dealer, distributor, or individual is authorized to amend, modify, or extend this warranty in any way. Accordingly, additional statements such as dealer advertising or presentations, whether oral or written, do not constitute warranties by Bad boy, Inc., and should not be relied on.

D. This warranty extends only to turf equipment operated under normal conditions and properly serviced and maintained. The warranty expressly does not cover (i) any defects, damage or deterioration due to normal use, wear and tear, or exposure; (ii) normal maintenance services such as oil change, cleaning, lubrication, adjustment; (iii) replacement of services, items, such as oil, lubricants, spark plugs, belts, rubber hoses or other items subject to normal service replacement; (iv) damage or defects arising out of or relating to misuse, neglect, alteration, negligence or accident; (v) repair or replacement arising from operation of or use of the turf equipment which is not in accordance with operating instructions as specified in the operator's manual or other operational instructions provided by Bad Boy Inc.; (vi) repair or replacement arising as a result of any operation from turf equipment that has been altered or modified so as to, indetermination of Bad Boy, Inc., adversely affect the operation, performance or durability of the equipment or that has altered, modified or affected the turf equipment so as to change the intended use of the product; (vii) repair or replacement necessitated by use of parts, accessories or supplies, including gasoline, oil or lubricants, incompatible with the turf equipment or other than as recommended in the operator's manual or other operational instructions provided by Bad Boy, Inc.; (viii) repairs or replacements resulting from parts or accessories which have adversely affected the operation, performance or durability of the turf equipment; or (ix) damage or defects due to or arising out of repair of turf equipment by person or persons other than an authorized Bad Boy, Inc., service dealer or the installation of parts other than genuine Bad Boy, Inc., recommended parts.

As a condition to this warranty, customer shall have read the operator's manual and shall have returned to Bad Boy, Inc., within the prescribed time, the enclosed warranty registration card.

E. This warranty gives you specific legal rights, and you may also have other rights, which vary from state to state.



Bad Boy, Inc.
102 Industrial Drive
Batesville, AR 72501
1.866.622.3269
www.badboymowers.com

Technical Support:

Brad Covington brad.covington@badboymowers.com
Bill Hurst bill@badboymowers.com
Taylor Prince taylor.prince@badboymowers.com
James Russell james.russell@badboymowers.com

Warranty:

Dustin Tissiere dustin@badboymowers.com
Bill Hurst bill@badboymowers.com

Parts:

Brad Foree brad@badboymowers.com
Robert Patterson robert.patterson@badboymowers.com



For additional information, please see us at

www.badboymowers.com

Bad Boy, Inc.

102 Industrial Drive

Batesville, Arkansas 72501

(870) 698-0090