



COMPACT DIESEL MODEL MOWER OWNER'S & PARTS MANUAL

2010 Edition

For additional information, please see us at

www.badboymowers.com

Bad Boy, Inc.

102 Industrial Drive

Batesville, Arkansas 72501

(870) 698-0090



TABLE OF CONTENTS

Basic Information..... Section 1 (pages 3, 4)

Bad Boy Safety Guidelines Section 2 (pages 5, 6)

Operation Section 3 (pages 6, 7)

Maintenance Section 4 (page 7)

Storage and Transportation Section 5 (page 8)

Adjustments..... Section 6 (pages 8, 9)

Troubleshooting and FAQ.....Section 7 (pages 9, 10)

Controls Section 8 (pages 10, 11)

Moving Inoperable Mower Section 9 (page 12)

InstrumentationSection 10 (page 13)

Blade Maintenance and Cutting Tips.....Section 11 (page 14)

Greasing Bearings..... Section 12 (pages 14, 15)

PARTS MANUAL BEGINS ON PAGE 16



This manual applies to the following equipment:

Bad Boy Compact Diesel Series
6000 Compact 28 hp Caterpillar Diesel

**ALL INFORMATION IN THIS MANUAL
MAY NOT APPLY TO YOUR MOWER!**



SECTION 1: BASIC INFORMATION

Congratulations on the purchase of your new Bad Boy Mower! The purpose of this manual is to assist operators in maintaining and operating their machine. The information and instructions in this manual can help you attain years of performance from your new Bad Boy. Also, check out our website to learn more about the Bad Boy family.

- 1.1 All Bad Boy engines use 10W30 engine oil.
- 1.2 All Bad Boy hydraulic systems use 20W50 engine oil.
- 1.3 All Bad Boy Mowers use hi-temp multi-purpose grease. NLGI No. 2 for the grease fittings.
- 1.4 ZT models have 12 psi in both front and rear tires.
- 1.5 Pups, AOS, and Diesel models have 12 psi in front tires and 10 psi rear tires.
- 1.6 Most Briggs, Kohler, Kawasaki, and Vanguard engines hold one (1) quart of motor oil.
- 1.7 3 Cylinder Caterpillar engines hold four (4) quarts of motor oil and 4 Cylinder Caterpillar Engines Hold five (5) quarts.

Warranty Registration

The Warranty Registration form must be completed and signed to validate your warranty. As the new equipment owner, you are expected to see that the form is completed and forwarded to Bad Boy, Inc., at time of delivery.

Model/Serial Number

Lightning, Pup, AOS, Diesel model serial numbers are found on the SIN plate, located underneath the floor panel. ZT model serial numbers are found on the SIN plate underneath seat. The serial numbers are necessary on the warranty registration form. Also, these numbers can assist you in the ordering of new parts when replacements become necessary.

Parts/Service

Only Bad Boy replacement parts are to be used on your mower.

Replacement parts are available through your local Bad Boy Mower Dealer. Remember to always provide the following information when ordering parts:

1. Correct part number
2. Correct serial number

All warranty repair and service must be handled through your authorized Bad Boy Mowers dealer. To locate the nearest dealer, go to our website and click on Locate a Dealer.



SECTION 2: MOWER OPERATION

Never allow untrained people to operate this machine. It is the owner's responsibility to get training and see to it that anyone who has permission to use your machine receives the proper training.

Do not mow around people. The factory discharge chute is designed to deflect debris downward, but it could be possible for debris to be thrown in a way that can cause damage to people or property.

Seek additional training when possible to learn more about safety techniques and practices.

SAFETY PRECAUTIONS

- 2.2 Always remain seated while operating machine.
- 2.3 Always maintain a safe distance from people and pets while mowing.
- 2.4 Always disengage blades, place steering controls in neutral, engage parking brake, and remove ignition key when leaving operators seat.
- 2.5 Always operate machine in daylight or with adequate working lights.
- 2.6 Be alert of surroundings. Watch for rocks, stumps, and mounds or depressions while mowing.
- 2.7 Always wear eye protection while mowing and servicing.
- 2.8 Always wear ear protection, such as earplugs, while mowing.
- 2.9 If you strike something with the mower turn the blades and mower off, engage the parking brake, and inspect the machine for damage before resuming.
- 2.10 Be aware of low hanging limbs or objects that could potentially be hazardous while mowing.
- 2.11 Never operate a poorly maintained machine.
- 2.12 Never carry passengers.
- 2.13 Always buckle seat belt, if provided one.
- 2.14 Never attempt high speed maneuvering, especially around people or property.
- 2.15 Never put hands or feet under the machine while ignition is on.
- 2.16 Never refuel machine when engine is running.
- 2.17 Never leave key in ignition, especially around children.
- 2.18 Never run engine in enclosed area.
- 2.19 Do not touch hot parts of machine.
- 2.20 Do not remove deck wheels.
- 2.21 Conditions that can affect traction resulting in the loss of control of machine: Wet terrain, Hills or extreme angles, Depressions in the ground, Mounds of dirt, Extremely dry grass, Soil type (gravel, sand, clay), Tire pressure
- 2.22 Be aware of what is located at the bottom of slopes. For example, Rocks, Water, Cliffs, Roads and Highways



2.23 Safety warning decals are located on the mower and should always be observed and followed.

- 2.24 Never operate the mower with the discharge chute open.
- 2.25 Prevent Fires—Remove grass and debris from engine compartment and muffler area, before and after operating machine, especially after mowing or mulching in dry conditions.
- 2.26 Do not store machine near open flame or source of ignition, such as a water heater or furnace.
- 2.27 Do not attempt to mount a tire without the proper equipment and experience to perform the job.
- 2.28 Always maintain the correct tire pressure. Do not inflate the tires above the recommended pressure. Never weld or heat a wheel and tire assembly. The heat can cause an increase in air pressure resulting in a tire explosion. Welding can structurally weaken or deform the wheel.
- 2.29 Never operate machine in a closed area where dangerous carbon monoxide fumes can collect.
- 2.30 Let engine cool before storing!!!
- 2.31 Hydraulic hoses and lines can fail due to physical damage, kinks, age, and exposure. Check hoses and lines regularly. Replace damaged hoses and lines.
- 2.32 Park machine on level ground. Never allow untrained personnel to service machine. Understand service procedure before doing work.

SECTION 3: MOWER OPERATION

Never operate the machine with faulty equipment. Always be alert of sudden changes in landscape, as the mower will react differently on slopes or embankments than it will on flat surfaces. Never operate the mower with the discharge chute open. Do not cross terrain, other than grass, with blades turning. This could cause damage to property or bystanders.

- 3.1 Place parking brake in up position
- 3.2 Drive arms must be in the “open” position. While sitting on the machine, each arm is positioned away from the operator, to the right and left. Drive arms will lock into place and must be in this position to start machine.
- 3.3 Put PTO switch in the OFF position.
- 3.4 If your machine has been equipped with a ROPS (Roll Over Protection System) then you must fasten seatbelt.
- 3.5 If machine has not been started recently, engage the choke.
- 3.6 Make sure nothing is under or around machine.
- 3.7 Place key in ignition and turn.
- 3.8 Once machine is started, disengage the choke.



-
- 3.9 Increase RPM by sliding the throttle to fast position, toward the rabbit.
 - 3.10 Owners must become familiar with the controls before operating a zero-turn radius vehicle.
 - 3.11 Start slowly and build your skill level. Have ample practice before using the machine at full capabilities.
 - 3.12 Be comfortable with machine before engaging blades. Know what each component controls before using machine.
 - 3.13 Your mower will perform differently on an incline /decline. Be cautious, slow down, and do not make any sudden jerking movements with control arms. The machine could lose traction on a decline or tip backwards on an incline.
 - 3.14 Once you become comfortable with your Bad Boy Mower you will notice your overall mowing time will decrease.

SECTION 4: MOWER MAINTENANCE

***Check each and provide maintenance when needed.*

DAILY

- 4.1 Check Engine Oil
- 4.2 Check Engine Air Filter
- 4.3 Tire Pressure
- 4.4 Radiator Screen (Screen should be cleaned frequently during heavy use)
- 4.5 Radiator Anti-Freeze
- 4.6 Inspect Blades

EVERY 30 HOURS OF USAGE

- 4.7 Grease Machine

EVERY 100 HOURS OF USAGE

- 4.8 Check All Filters

Check filters once a year if under 100 hours

Check air and fuel filters more often in dry, dusty conditions

EVERY 100 HOURS OF USAGE

- 4.9 Change Hydraulic Fluid
- 4.10 Refer to manufacturer manual for specific information on maintenance schedules.



SECTION 5: MOWER STORAGE

- 5.1 Keep machine from collecting debris by storing in a covered area while not in use.
- 5.2 Fuel can harm your machine if left for more than 30 days without changing.
- 5.3 Disconnect the negative battery cable when machine will be stored for more than 30 days.
- 5.4 Always secure machine properly when transporting machine.
- 5.5 Do not load machine on trailer with blades engaged.
- 5.6 Do not use ramps to load the machine.
- 5.7 Make sure Parking Brake is in “up” position.
- 5.8 In wet conditions tires may spin while loading / unloading. If necessary, wait for dry conditions before loading / unloading.
- 5.9 Make sure mode of transportation is suitable to bear the weight of mower.
- 5.10 Deck height should be set at maximum before attempting to load.
- 5.11 Secure mower with at least two straps capable of securing weight of mower.

SECTION 6: MAINTAINING YOUR MOWER

DECK LEVELING

- 6.1 Put mower on flat, level surface
- 6.2 Check tire air pressure
- 6.3 Put deck on highest setting
- 6.4 Measure all four corners of the deck. Deck level should be the same from front left to right.
- 6.5 Set front corners to 1/8” lower than rear corners. (This is the distance from the bottom of mower deck to the ground).
- 6.6 Use the deck hanger chains to raise or lower entire deck.
- 6.7 Use turnbuckles for raising and lowering the front of the deck.

BRAKE ADJUSTMENT

- 6.8 Locate set screw on top of brake handle knob
- 6.9 Turn knob on top of brake lever clockwise to loosen brake cable.
- 6.10 DO NOT OVER ADJUST – CABLE BREAKAGE MAY OCCUR.

DRIVE ARM ADJUSTMENT

- 6.11 Due to the sensitive nature of drive arm adjustments visit an Authorized Bad Boy Dealer and they'll be happy to help you with this.



STANDARD HYDRAULIC/ OIL/FILTER SERVICING PROCEDURE

- 6.12 On all Bad Boy ZT Models, the hydraulic oil filters need to be initially changed when the mower has reached 50 hours of usage. Each subsequent changing of the hydraulic oil and filters needs to occur every 250 hours or once a year. The required hydraulic oil is 20W50 motor oil. On all Bad Boy commercial models, the hydraulic oil and filters need to be initially changed when mower has reached 50 hours of usage. Each subsequent changing of the hydraulic oil and filters needs to occur 500 hours or once a year. The required hydraulic oil is 20W50 motor oil.

SECTION 7: TROUBLESHOOTING

7.1 **Q:** *How do I sharpen my blades?*

7.1 **A:** We recommend that sharpening be done by an authorized Bad Boy dealer.

7.2 **Q:** *How should I prepare my Bad Boy Mower for the off season?*

7.2 **A:** When preparing for any down period of 90 days or more, the most important thing is proper fuel preparation. Use a fuel stabilizer in your final tank of fuel or run dry. Choke and repeatedly crank engine until it will not start. This will decrease the potential for varnish or gum deposits forming in your system. Also, make sure your machine has plenty of antifreeze. You can get an antifreeze tester at your local hardware store to ensure your machine is ready for winter.

7.3 **Q:** *How do I prevent an uneven cutting pattern and increase the quality of cut?*

7.3 **A:** Check tire pressure, check blade sharpness (replace blades or sharpen at least once per year or when needed), make sure blades are tightened properly, check spring and belt tension, check the underside of the deck to ensure the mower deck is free of grass build-up and debris, make sure your machine is at full throttle, and vary your mowing pattern each time you cut your grass.

7.4 **Q:** *What should I do if my mower won't start?*

7.4 **A:** Check battery charge and connection (grounds), check your fuel (make sure fuel is less than 30 days old and contains no water), make sure your spark plug is in good condition and spark plug wire is attached, and make sure air filter is clean (a dirty filter makes it more difficult for the engine to draw air). Check for broken wires or bad connections.

7.5 **Q:** *What should I do if the blades won't engage?*

7.5 **A:** Make sure the safety switch is plugged in on the bottom of seat. Check the underside of the PTO engager to ensure the plug is secure at switch.

7.6 **Q:** *What should I do if mower arms are in neutral position and mower still creeps?*

7.6 **A:** Contact authorized Bad Boy Mower Dealer.



7.7 **Q: What is the difference between a liquid-cooled engine and an air cooled-engine?**

7.7 **A:** A liquid-cooled engine gives you a constant operating temperature which will increase fuel economy, decrease oil breakdown, and may last up to 50% longer. In addition, a cooler engine also means a cooler operator because the cooling fan draws hot air through the radiator, past the engine and away from the operator. An air-cooled engine is much simpler with fewer working parts which means a lower purchase price and less maintenance

7.8 **Q: What type of fuel is recommended for my mower?**

7.8 **A:** We recommend that you use a name brand fuel to ensure quality. Use fuel with an octane rating near 87. Higher octane fuels offer no benefit.

7.9 **Q: Does the Bad Boy warranty cover multiple owners?**

7.9 **A:** The warranty applies only the original registered owner and is non-transferable.

7.10 **Q: Do you offer touch-up paint for your mowers?**

7.10 **A:** Touch-up paint is available. Contact your local dealer for more information.

7.11 **Q: On average, how long should a Bad Boy mower last?**

7.11 **A:** Maintenance, mowing conditions, temperature, and hours of operations play a huge role in the life of a mower. However, Bad Boy Mowers are without a doubt the strongest, most durable zero-turn mower available. With proper care, your Bad Boy will deliver many years of reliability, productivity, and comfort.

7.12 **Q: How durable is the electric deck lift?**

7.12 **A:** The actuator which controls the deck height is designed for moving loads of up to 1000 pounds and has a static holding capability which exceeds 3,000 pounds. Our 1/4" deck weighs approximately 250 pounds which is only 25% of working capability.

SECTION 8: CONTROLS

8.1 **Ignition Switch**—Bad Boy Mowers have a three position ignition switch: off, run, and start. With key inserted, rotate it clockwise to START position and release key when engine starts, and switch will automatically return to the RUN position.

8.2 **Throttle Control**—A cable is connected to the engine throttle for controlling engine speed. Move lever forward to increase engine rpm, move lever backward to decrease engine rpm.



- 8.3 **Choke Control**—A cable is linked to manually operate the engine choke. When the lever is in the down position, the choke is in the off (run) position. When the lever is pulled up, the choke is in the on (start) position. Do not operate the machine in the on (start) position. The choke lever is behind the throttle control.
- 8.4 **Control Levers**—These levers control the mower's speed, direction, and neutral lock. These levers are used to steer, accelerate, decelerate and change direction. (Drive Arms)
- 8.5 **Blade Engage Switch**—This switch engages the blades. Pull the switch up to engage the blades and push the switch down to disengage the blades.
- 8.6 **Deck Lift Control**—The deck lift switch is used to raise and lower the deck. Pull the switch backwards to raise the deck and push the switch forward to lower the deck.

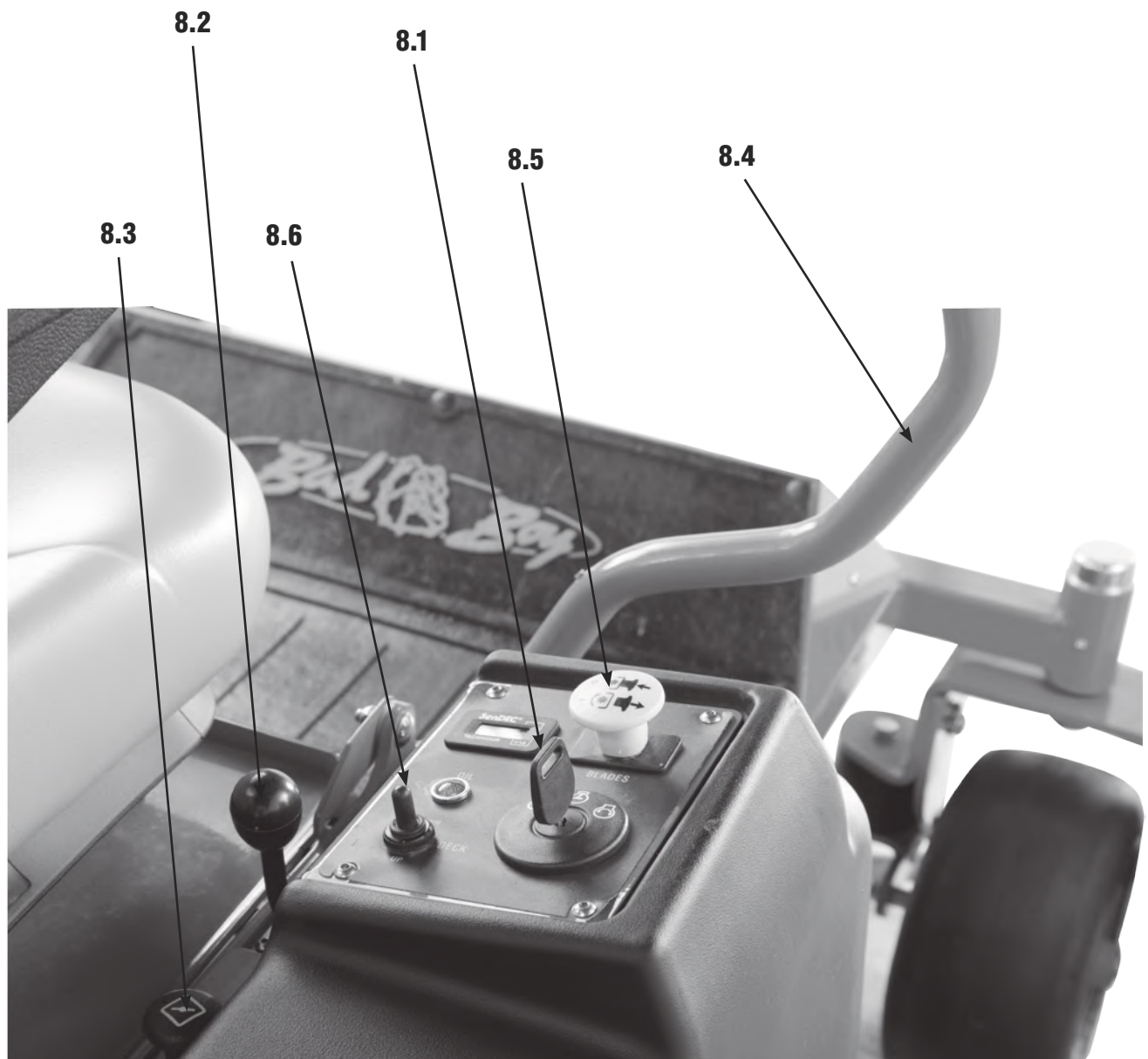



SECTION 9: MOVING INOPERABLE MOWER

- 9.1 If it is necessary to move mower when the engine is inoperable, the hydraulic drive pumps are equipped with bypass valves. Before moving the mower, turn the bypass valves counter-clockwise one-half to one revolution. The valve stems on each pump are located near the top and are identified as a hex stud.
- 9.2 Do not tow machine. Move it by hand or use a winch to load on a trailer for transporting.
- 9.3 **ATTENTION:** RETURN BYPASS VALVES TO OPERATING POSITION BEFORE RUNNING MOWER FOLLOWING REPAIRS.
- 9.4 ZT Models are equipped with two neutral engage/disengage arms, located at the rear of the mower protruding from the frame and under the muffler. By pulling the arms out the mower can be put in a neutral position. Return the arms to the “forward position for normal operation.
- 9.5 Your Bad Boy Mower Weighs:
- | | |
|------------------------------------|------------------------|
| ZT SERIES: | 900—950 lbs |
| PUP & LIGHTNING SERIES: | 1,050—1,300 lbs |
| AOS SERIES: | 1,275—1,350 lbs |
| DIESEL SERIES: | 1,525—1,600 lbs |
- *** Weights fluctuate with the addition of accessories.*
- 9.6 As you can see by the weights of the machines, you shouldn't ever try to push or pull a Bad Boy Mower by hand. This could cause serious bodily injury.
- 9.7 Hopefully, you'll never need to use this section of the manual. However, if you do, use extreme caution when moving machine!



SECTION 10: INSTRUMENTATION

- 10.1 **Electronic Hour Meter**—Registers Hour increments up to 9,999.9 total hours. This meter records the cumulative time the engine is running.
- 10.2 **Oil Pressure Light**—This light comes on upon placing the ignition switch in the RUN position and stays lit until the engine is running and a safe oil pressure is built up. If the light comes on during operation, shut the engine off immediately and locate the problem or contact authorized Bad Boy Mower dealer.
- 10.3 **High Temperature Buzzer**—Liquid-Cooled models are equipped with a buzzer that will sound in the event of high water temperature.

IF THIS HAPPENS SHUT ENGINE OFF IMMEDIATELY! Allow engine to cool. Check for obstructions in or around radiator or contact your local Bad Boy Mower Authorized Dealer.

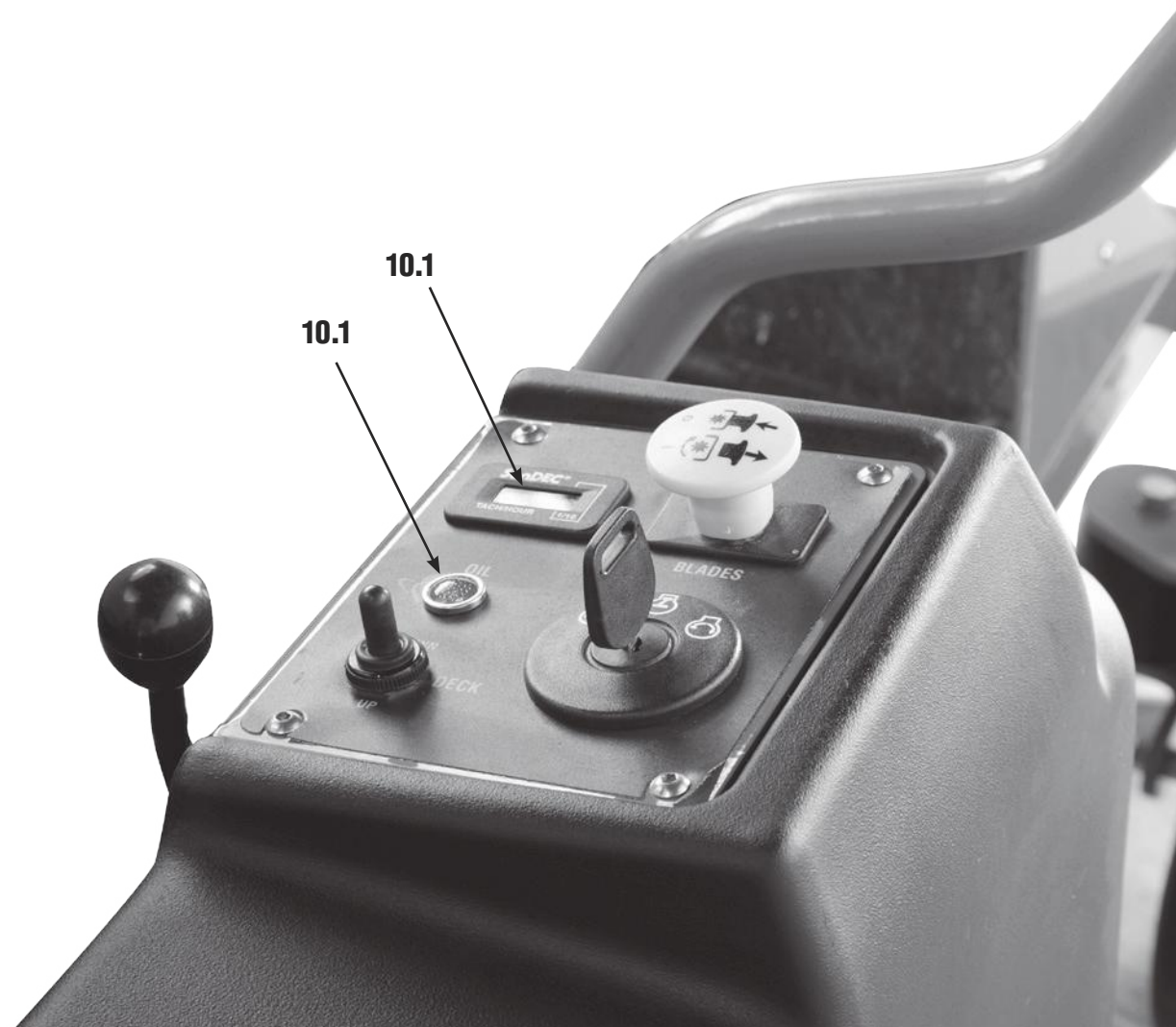



SECTION 11: MOWER BLADE MAINTENANCE

- 11.1 Check mower blades after each use. This is essential for maintaining well-groomed turf. Keep the blades sharp. If a dull blade is used for cutting, the grass will tear rather than cut. This could damage the grass leaving a brown frayed top on the grass within a few hours. A dull blade will also require more power from the engine.
- 11.2 NEVER attempt to straighten a bent blade by heating. NEVER attempt to weld a cracked blade. The blades can break and cause serious injury or death.
- 11.3 NEVER work with blades while engine is running or deck clutch is engaged.
- 11.4 ALWAYS place deck clutch in DISENGAGE position while performing maintenance.
- 11.5 Use blocks when you MUST work under mower.
- 11.6 ALWAYS wear thick gloves when handling blades.
- 11.7 ALWAYS check for blade damage if mower strikes rock, branch, or other objects that could potentially damage the blade. **(REMEMBER: NEVER CHECK BLADE WHILE ENGINE IS ON! NEVER CHECK BLADES WHILE BLADES ARE ENGAGED!)**
- 11.8 Cut 1/3 of the height GRASS BLADE. Cutting more than that is not recommended unless grass is sparse, or it is late fall when grass grows slowly.
- 11.9 Alternate mowing direction to keep grass standing straight. This also helps disperse clippings which enhance decomposition and fertilization.
- 11.10 Mow in intervals. Usually, you should mow every four days. However, grass grows at different rates at different times of the year. Maintain the same cutting height and mow often in early spring. As grass growth slows in the summer, mow less frequently.
- 11.11 Mowing too fast will tend to leave grass stems standing, if this occurs, slow down you mowing speed. (Oftentimes, leaving streaks depends on the composition of the grass being cut, the sharpness of mower blades, and the moisture of the grass).

SECTION 12: GREASING THE BEARINGS

- 12.1 Park the machine on a level surface and disengage the blade control switch.
- 12.2 Move the motion control levers outward to the neutral position, engage parking brake, stop the engine, remove the key, and wait for all moving parts to stop before leaving the operating position.
- 12.3 Grease Type: NLGI grade #2 multi-purpose gun grease. Grease the front cater pivots.
- 12.4 Clean the grease fittings with a cloth. Scrape any paint off the front of the fitting(s).
- 12.5 Connect a grease gun to each fitting. Pump grease in fittings until greases begins to seep out of the bearings. Wipe up excess grease.
- 12.6 Total Number of fittings for most models is 14.



- | | | |
|-------------------|---------------------|----------------|
| (2) Front Tires | (2) Actuator Blocks | (2) Pivot Arms |
| (2) Front Forks | (1) Pump idler | |
| (4) Steering Arms | (1) Deck Idler | |

If you purchased a ZT Series Mower, your fuel tanks will not Swing-Away like the illustration shown on this page. The Swing Away feature is only available on the Pup, Lighting, AOS, and AOS Diesel Series

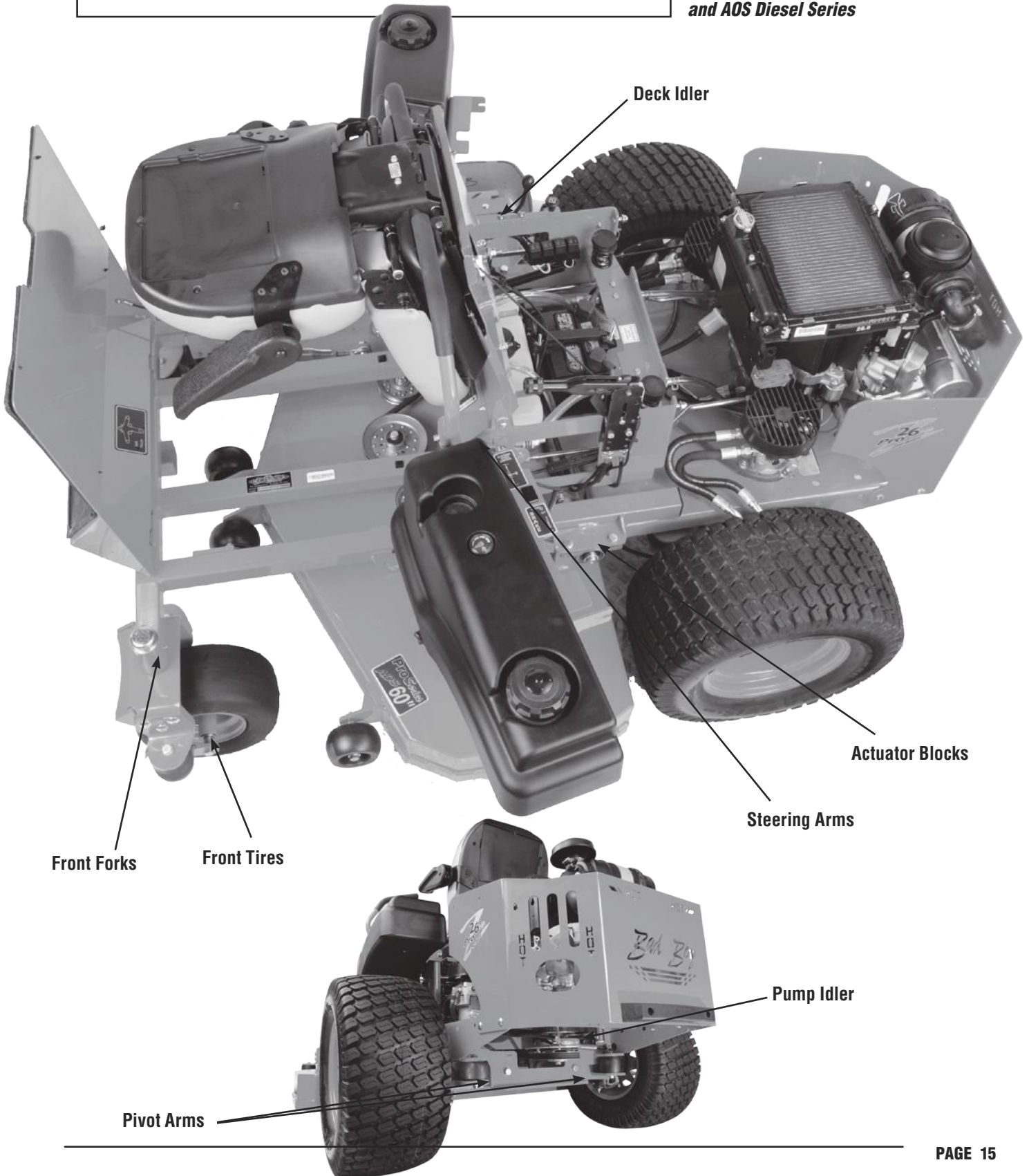



PARTS MANUAL FOR YOUR

**Compact Diesel
Model
Zero Turn Mower**



Diesel Actuator Bar

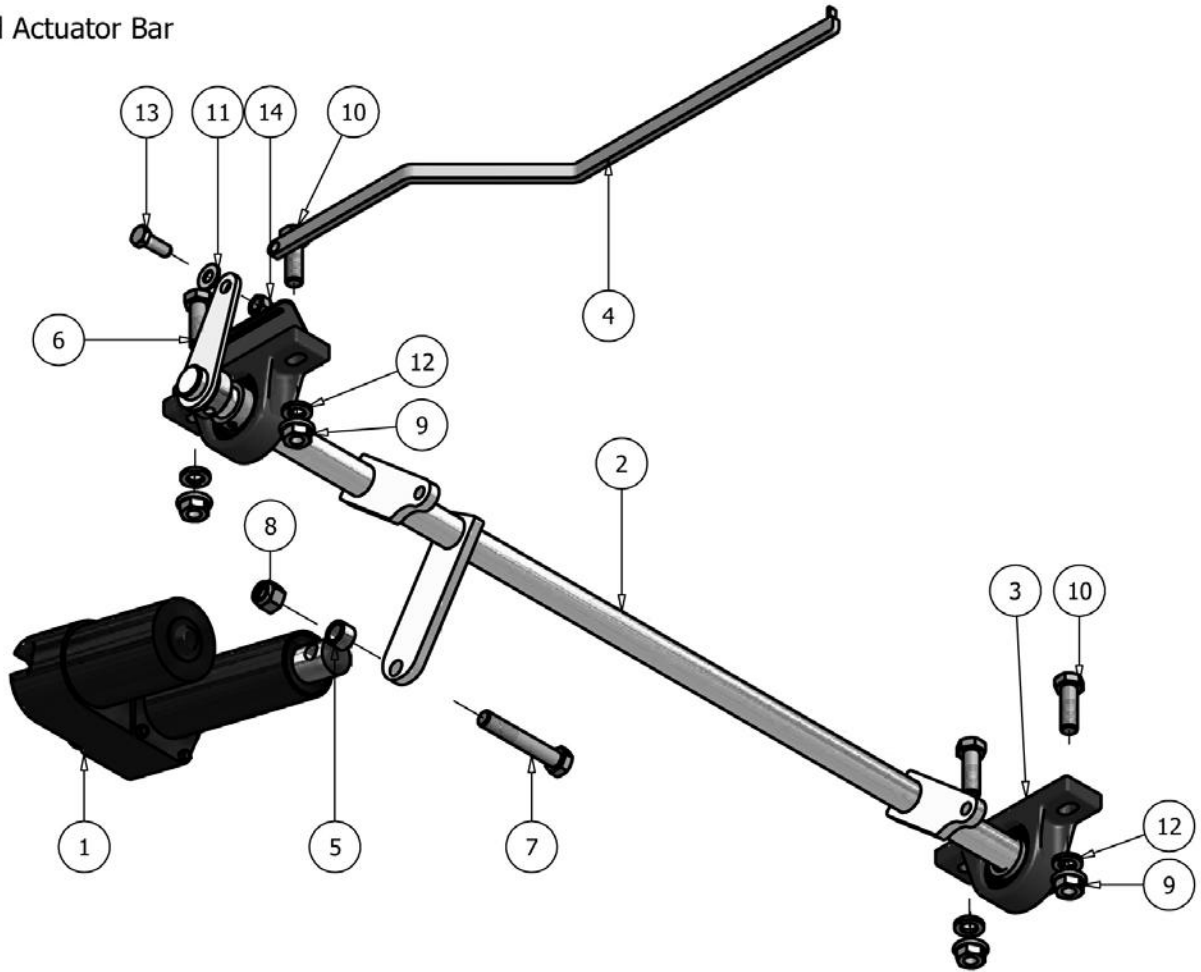

Actuator Bar			
ITEM	QTY	PART NUMBER	DESCRIPTION
1	1	035-7033-00	Actuator
2	1	028-7930-00	Actuator Bar
3	2	017-7008-00	1" Pillow Block
4	1	028-5203-00	Height Indicator
5	2	019-5702-00	1/2" Washer
6	1	031-7000-00	2006 Height Indicator Lever
7	2	018-6036-00	1/2" x 2 1/2" Hex Bolt
8	2	013-6037-00	1/2" Nylock Nut
9	4	013-5300-00	1/2" Flange Nut
10	4	018-5600-00	1/2" x 1 1/2" Hex Bolt
11	1	019-6042-00	.360 ID Plastic Washer
12	4	019-5007-00	1/2" Lock Washer
13	1	018-6049-00	3/8" x 1" Hex Bolt
14	1	013-5041-00	3/8 Nylock Nut

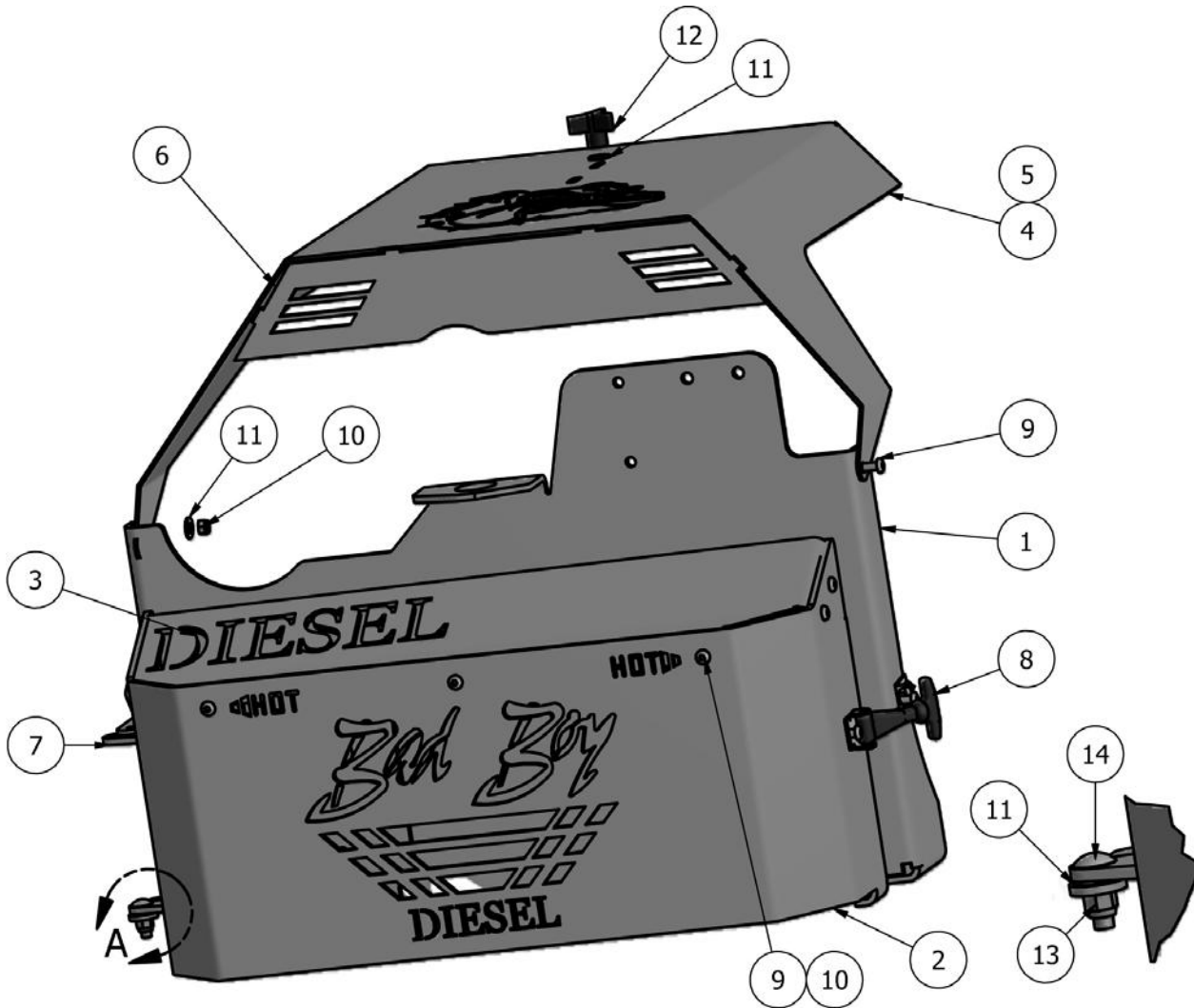

DETAIL A
SCALE 1 / 3

Parts List			
ITEM	QTY	PART NUMBER	DESCRIPTION
1	1	026-8030-00	Pump Plate
2	1	014-5920-00	Back Pump Cover
3	1	059-8000-00	Top Back Cover
4	1	059-8010-00	35 HP Hood
5	1	059-8020-00	28 HP Hood
6	1	059-8011-00	Back Cover For Hood
7	1	039-0070-00	Pump Cover Hinge
8	1	052-5020-00	Pump Cover Latch
9	9	018-5007-00	5/16" x 3/4" Bolt
10	9	013-8047-00	5/16" Nylock Nut
11	5	019-6042-00	.360 ID Plastic Washer
12	1	045-6043-00	5/16" Knob
13	2	013-8047-00	5/16" Nylock Nut
14	2	018-8065-00	5/16" x 3/4" Carriage Bolt



Compact Diesel Pump Plate

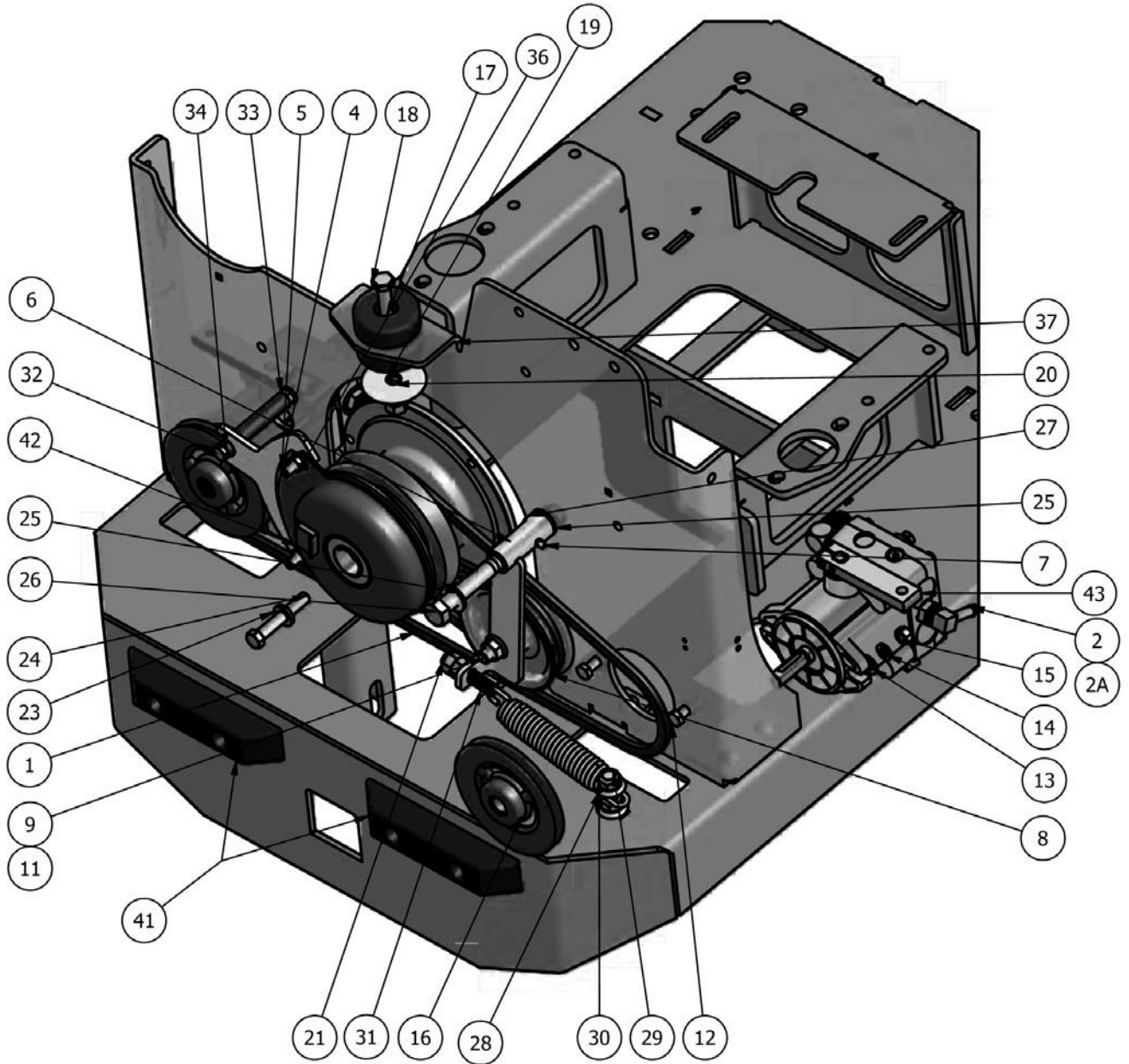



Compact Diesel Pump Plate			
ITEM	QTY	PART NUMBER	DESCRIPTION
1	1	041-8411-00 (72 Deck)	Pump Belt
1A	1	041-5048-00 (60 Deck)	Pump Belt
2	1	050-5500-00	Hydraulic Pump with Fan and Cover Left
2A	1	050-5501-00	Hydraulic Pump with Fan and Cover Right
3	1	070-5040-00	Diesel Clutch
4	1	057-5910-10	Diesel PTO Engager Holder
5	8	018-5043-00	3/8" x 1 1/4" Carriage Bolt
6	1	039-5944-00	Pump Idler Bracket (60 Only)
7	1	024-6034-00	1/4" Drive-in Grease Fitting
8	1	033-6001-00	4 3/4" Idler Pulley
9	1	018-5049-00	1/2" x 2" Hex Bolt
10	2	032-6033-00	5/8" x 1 1/8" Brass Bushing
11	1	013-5300-00	1/2" Flange Nut
12	4	018-6012-00	3/8" x 1 1/4" Hex Bolt
13	4	019-5029-00	3/8" Flat Washer
14	4	019-5037-00	3/8" Lock Washer
15	4	013-6014-00	3/8" Hex Nut
16	2	033-5011-00	5" Pump Pulley
17	1	032-4000-00	Rubber Isolator
18	1	018-7016-00	1/2" x 3" Bolt
19	1	019-2040-00	1/2" Flat Washer
20	1	019-5007-00	1/2" Lock Washer
21	3	013-7018-00	1/2" Hex Nut
22	1	013-5301-00	5/8" Nylock (1/2 Jam)
23	1	019-8053-00	7/16" Lock Washer
24	1	018-5401-00	7/16" x 2 3/4" Fine Thread Bolt
25	2	019-6017-00	.635 ID Plastic Washer
26	1	018-5312-00	5/8" x 4 1/2" Hex Bolt
27	1	025-7036-00	1/2" Collar Spacer
28	1	034-5039-00	6" Pump Idler Spring
29	1	018-1050-00	1/2" x 2" Carriage Bolt
30	2	013-8050-00	1/2" Nylon Flange Nut-Orange
31	1	018-2004-00	1/2" x 2 1/2" All Thd Stud
32	1	018-2005-00	3/8" x 4 1/2" Bolt
33	2	013-5201-00	3/8" Flange Nut
34	1	051-8067-00	Rubber Spacer
35	1	017-3000-00	Stub Shaft
36	2	013-5202-00	3/8" Nylock Flange Nut
37	1	026-8030-00	Pump Plate Diesel
38	1	033-4050-00	5" Idler Pulley
39	1	018-6016-00	5/8" x 5 1/2" Hex Bolt
40	1	070-2000-00	Clutch Pigtail
41	2	029-7038-00	8" Rubber Bumper
42	1	025-7020-00	5/8" Set Collar
43	2	031-5923-00	Pump Arm



Wheel Motor/Tire and Wheel Assembly

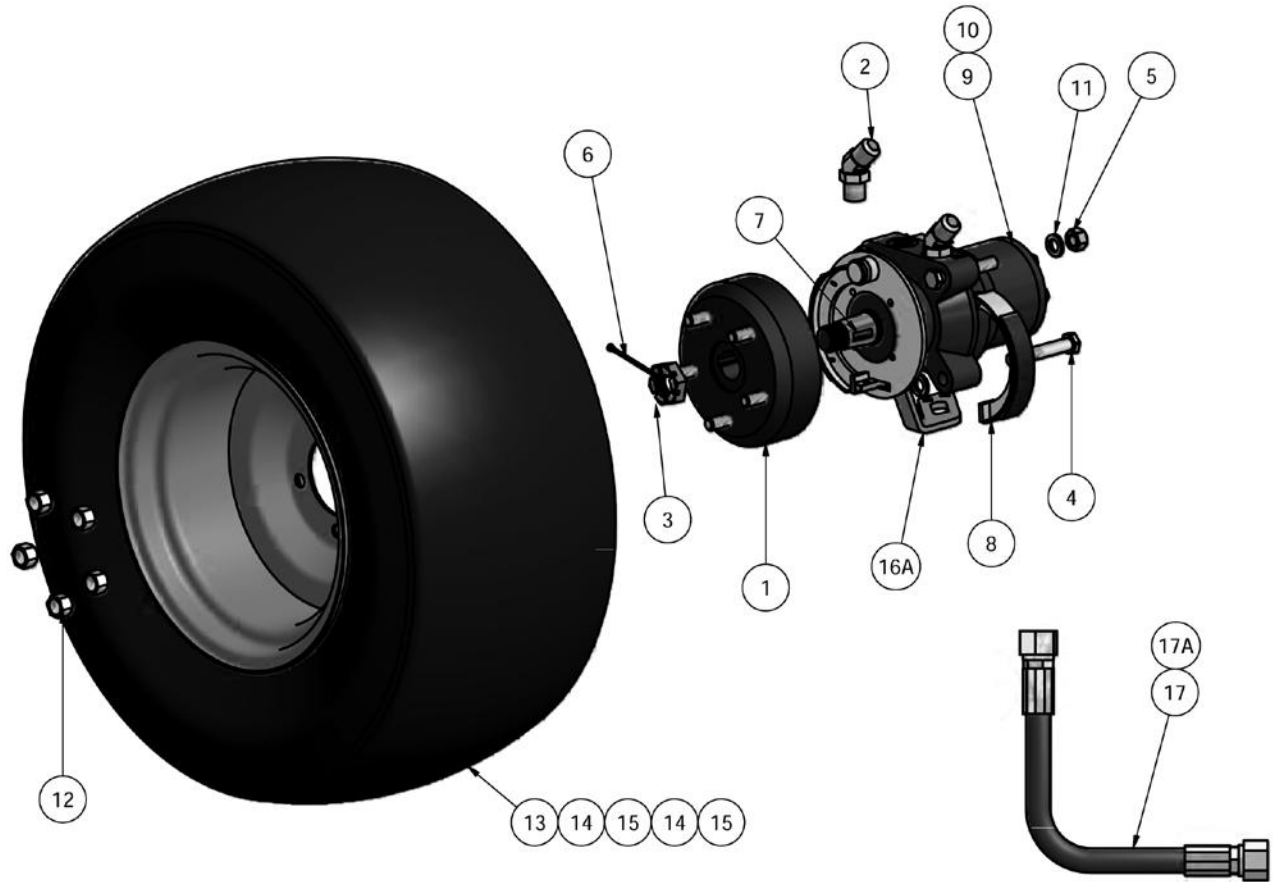

Parts List			
ITEM	QTY	PART NUMBER	DESCRIPTION
1	1	092-6000-00	Brake Drum
2	2	024-2050-00	Hydraulic Fitting
3	1	013-7050-00	Castle Nut
4	4	018-7016-00	1/2" - 13 x 3" GRS Hex Bolt Zinc
5	4	013-7018-00	1/2" Hex Nut
6	1	020-7022-00	1/8"x2 1/4" Cotter Pin
7	1	042-7041-00	Woodruff Key
8	2	092-6050-00	Brake Shoe
9	1	015-5006-98	Wheel Motor and Drum Brake Combo-18E Right
10	1	015-5007-98	Wheel Motor and Drum Brake Combo-18E Left
11	4	019-5007-00	1/2" Lock Washer
12	5	013-3000-00	Lug Nut
13	1	022-7034-00	12" Rim
14	1	022-5349-00	24" x 12-12 Tire (Compact Diesel)
15	1	022-5450-00	24" Tire and Wheel Assembly
16	1	031-0011-00	Brake Lever (wheel motor) Left
16A	1	031-0012-00	Brake Lever (wheel motor) Right (Shown)
17	2	051-6075-00	Hydraulic Hose
17A	2	051-6085-00	26" Hydraulic Hose (Compact Diesel)



Floor Board

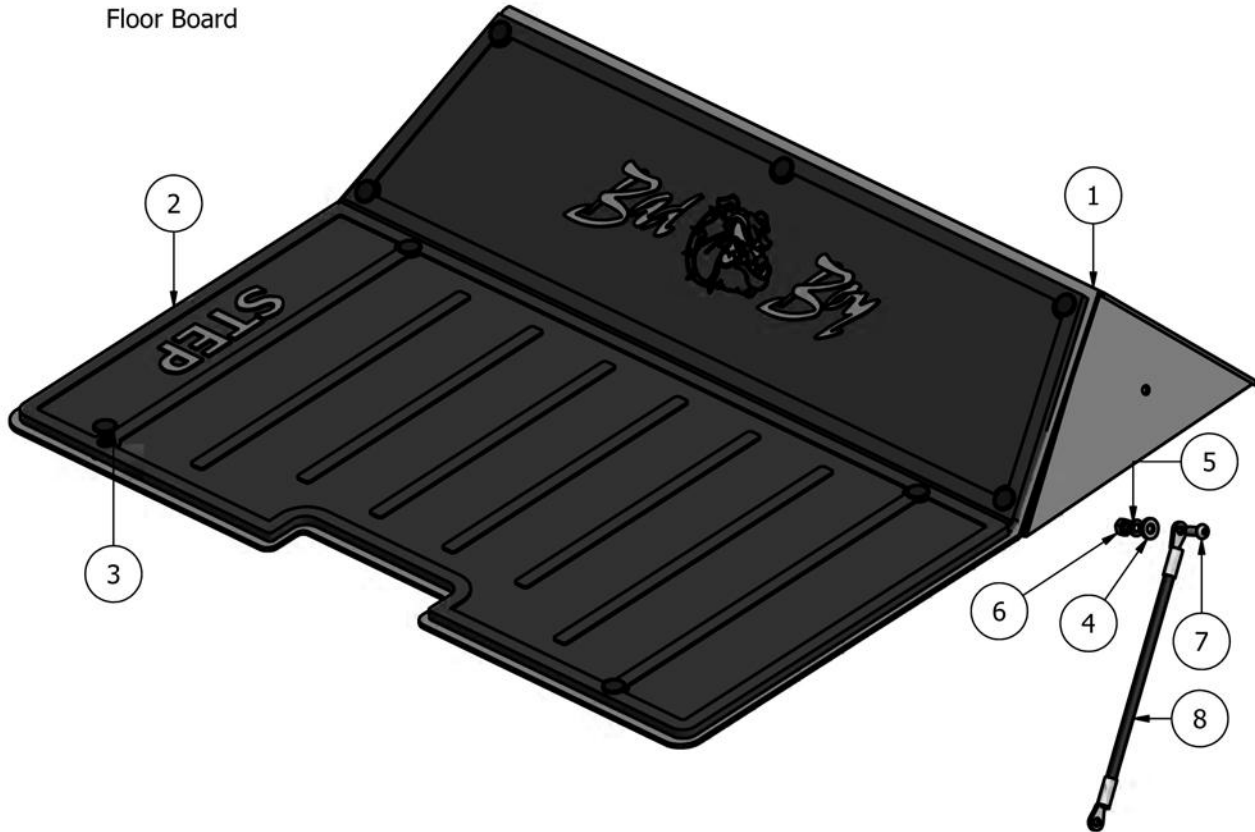

Parts List			
ITEM	QTY	PART NUMBER	DESCRIPTION
1	1	079-6000-00	Floor Panel
2	1	081-2007-00	Floor Mat
3	9	040-6080-00	Ratchet Fastener
4	1	019-7040-00	1/4" Flat Washer
5	1	019-4008-00	1/4" Lock Washer
6	1	013-8039-00	1/4" Hex Nut
7	1	018-8064-00	1/4" x 5/8" Buttonhead Bolt
8	1	064-2005-00	Floor Panel Cable



Compact Diesel Seat Frame

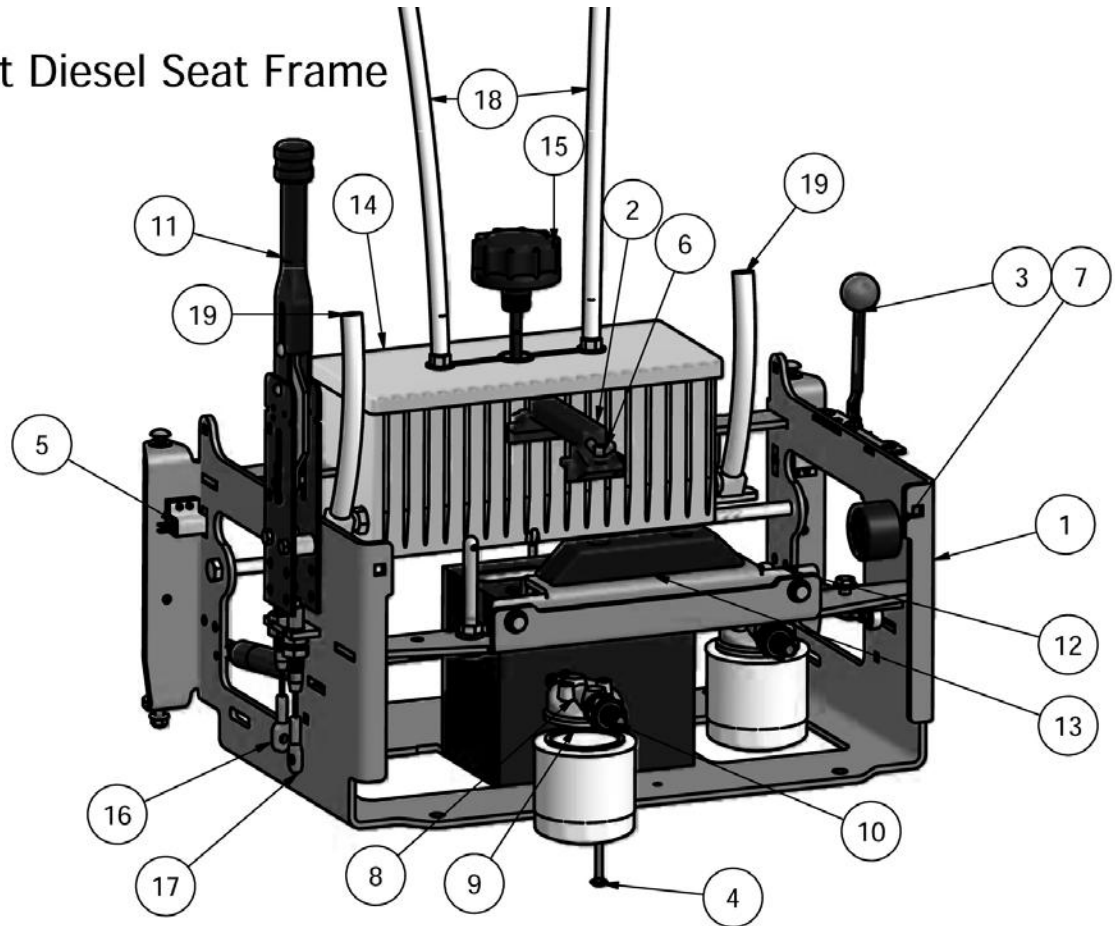

Parts List

ITEM	QTY	PART NUMBER	DESCRIPTION
1	1	080-6050-00	Seat Frame
2	1	043-8929-98	Battery Hold Down
3	1	055-8017-00	Throttle Lever Assembly
4	2	018-8051-00	9" Stove Bolt
5	2	077-8073-00	Safety Switch
6	2	013-8051-00	1/4" Wing Nut
7	1	029-8059-00	buzzer
8	2	062-8013-00	Filter Head
9	2	063-8014-00	Hydraulic Filter
10	4	024-5203-00	Filter Head Fitting
11	1	069-8054-00	Hand Brake Assembly
12	1	039-3005-00	Compact Diesel Seat Bumper Bracket
13	1	029-7038-00	8" Rubber Bumper
14	1	067-2010-00	Aluminum Hydraulic Tank
15	1	066-8050-00	Hydraulic Tank Cap
16	1	064-8055-00	Short Brake Cable
17	1	064-8056-00	Long Brake Cable
18	2	051-8063-00	3/8" x 32" Clear Hose
19	2	051-8064-00	1/2" x 9 1/4" Braided Hose



Adjustable Drive Arm

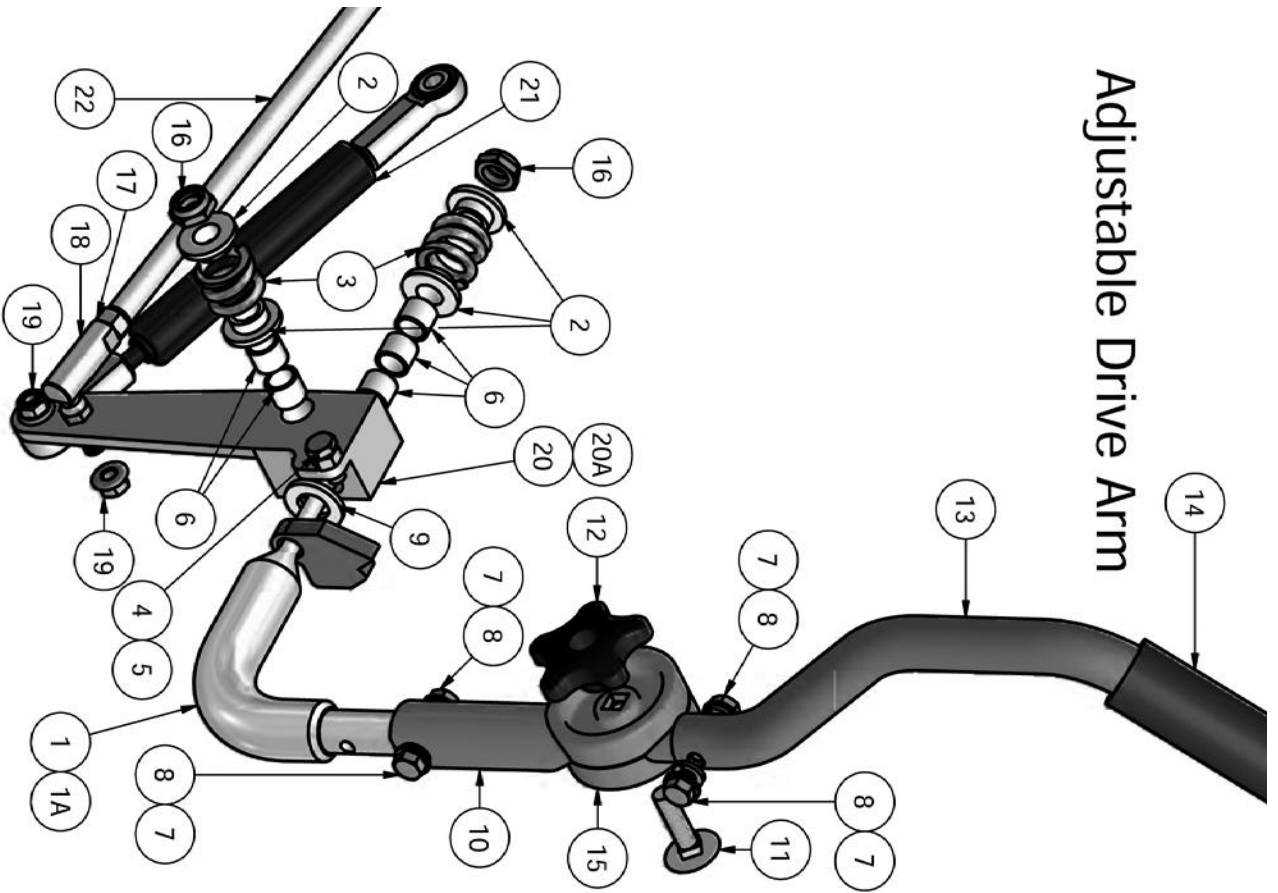

Parts List

ITEM	QTY	PART NUMBER	DESCRIPTION
1	1	031-9025-00	Steering Arm Base-Right
1A	1	031-9020-00	Steering Arm Base-Left
2	4	019-8027-00	.515 ID Nylon Shoulder Washer
3	2	034-8025-00	Drive Lever Spring
4	1	018-8063-00	5/16" x 3/4" Hex Bolt
5	1	013-8043-00	5/16" Nut
6	5	032-8024-00	.507 ID Nylon Bushing
7	4	019-8051-00	5/16" Lock Washer
8	4	018-2007-00	5/16" x 1/2" Flange Bolt
9	1	019-6017-00	.635 ID Plastic Washer
10	1	031-9016-00	Upper Adjuster for Steering Arm
11	1	018-5043-00	3/8" x 1-1/4" Carriage Bolt
12	1	045-5000-00	Black Knob for Adjustable Steering Arm
13	1	031-9010-00	Upper Steering Arm Tubing-Adjustable
14	1	069-4010-00	Rubber Grip
15	1	031-9015-00	Lower Adjuster for Steering Arm
16	2	018-4010-00	1/2" Nylon Nut (1/2 Jam)
17	2	013-6051-00	3/8" Fine Threaded Jam Nut
18	2	099-6046-00	3/8-24 Ball joint (female/male)
19	2	013-9002-00	5/16" Flange Nut
20	1	027-8820-00	Drive Arm Lever Housing (Right)
20A	1	027-8819-00	Drive Arm Lever Housing (Left)
21	1	087-8080-00	Damper
22	1	035-6060-00	Push Rod for Compact Diesel



Front Cast Suspension

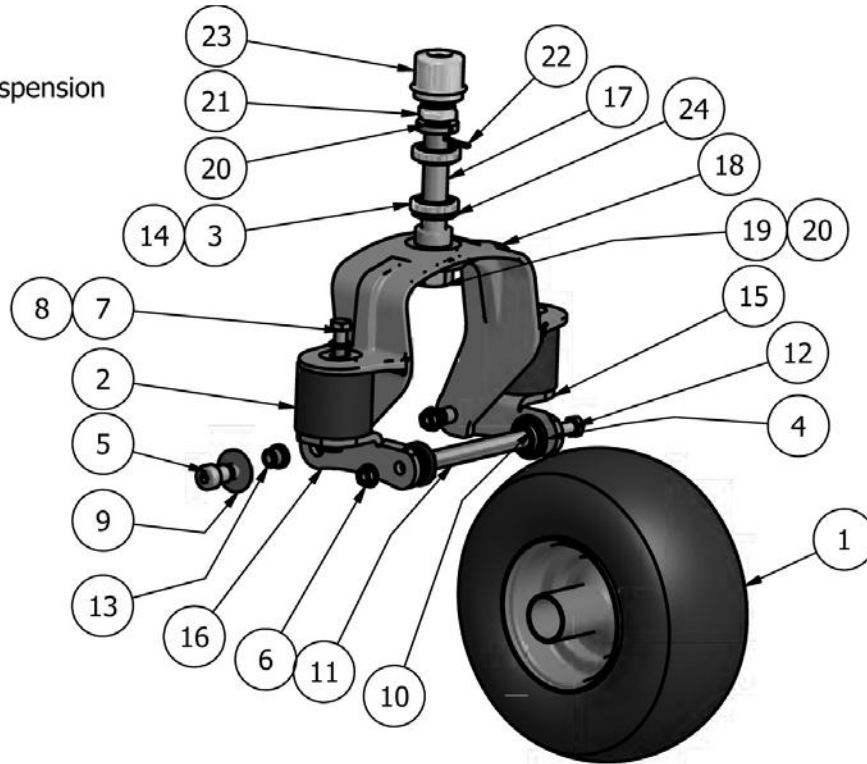

Parts List			
ITEM	QTY	PART NUMBER	DESCRIPTION
1	1	022-3060-00	13" x 6.50 - 6 Tire and Wheel
1a	1	022-3070-00	13" x 6.50 - 6 NO-Flat Tire and Wheel (Diesel Only)
2	2	032-9002-00	Rubber Isolator
3	2	010-7001-00	Caster Bearing
4	2	022-7010-00	Large Bore Bearing
5	2	018-3001-00	5/8" x 5/8" Shoulder Bolt
6	3	013-8050-00	1/2" Nylock Nut
7	4	018-5006-00	1/2" x 1 1/2" Hex Bolt
8	4	019-5007-00	1/2" Lock Washer
9	2	019-5038-00	5/8" Flat Washer
10	2	025-5203-00	3/4" OD x 1/2" ID x 3/4"
11	1	025-5202-00	7" x 1/2" ID Tire Spacer
12	1	018-3002-00	1/2" x 10" Bolt
13	2	032-5052-00	5/8" Shoulder Bushing
14	2	011-7002-00	Race
15	1	023-0013-00	Suspension Fork-Bottom Right
16	1	023-0012-00	Suspension Fork-Bottom Left
17	1	037-0010-00	Spindle Shaft
18	1	023-7915-98	Suspension Fork Assembly
19	1	013-6016-00	1" Hex Nut
20	2	019-3000-00	1" Lock Washer
21	1	013-9004-00	1" Fine Thread Nylock Half Nut
22	1	020-3000-00	Cotter Pin
23	1	014-7005-00	Dust Cover
24	1	012-7003-00	Seal



Suspension

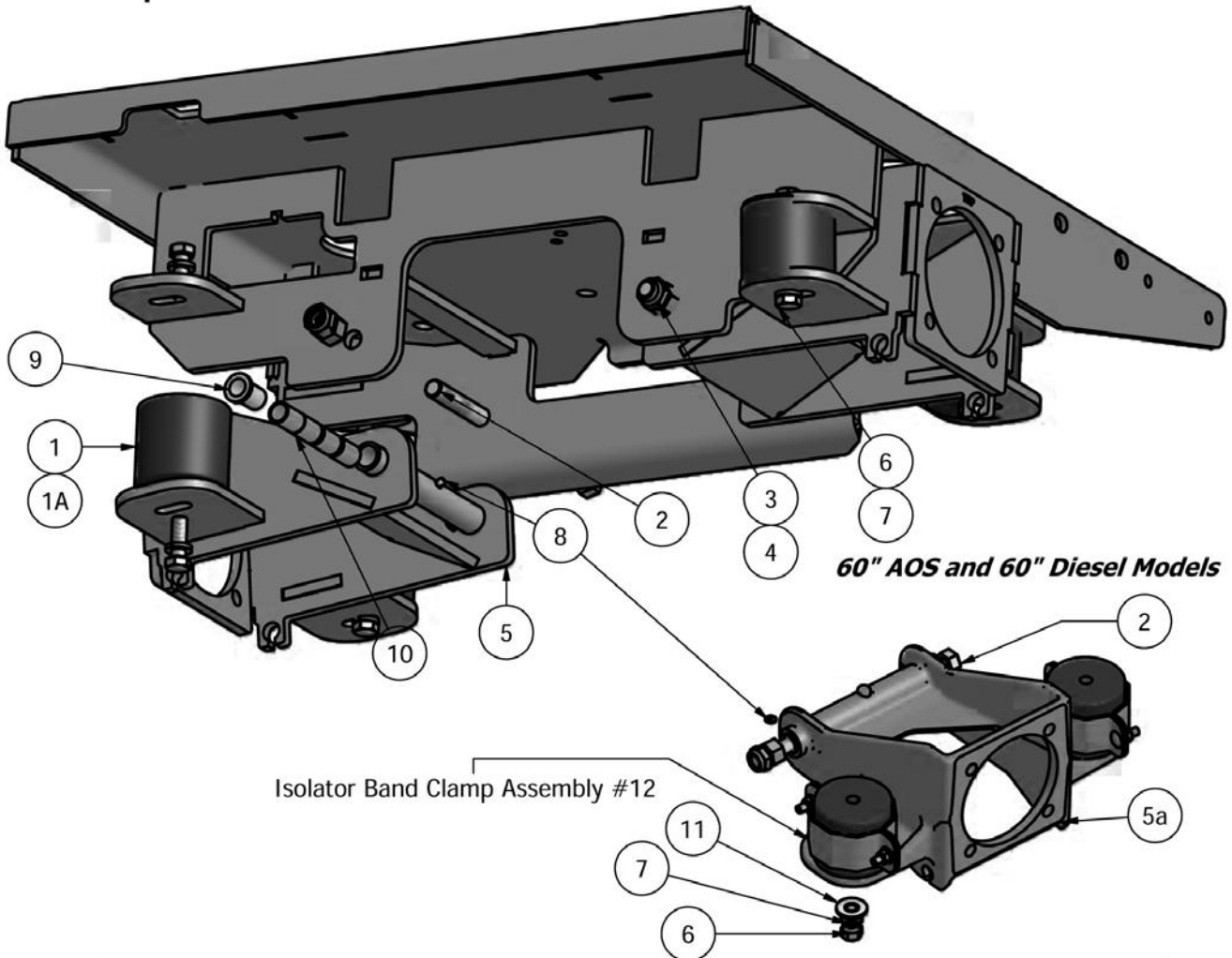

Isolator Band Clamp Assembly #12

Parts List			
ITEM	QTY	PART NUMBER	DESCRIPTION
1	4	032-9000-00	Vibration Mount-Green Dot (60" Only)
1A	4	032-8999-00	Vibration Mount-Blue Dot (72" AOS and All Diesel)
2	2	018-2051-00	5/8"x10" Hex Bolt (Grade8)
3	2	013-5301-00	5/8" Nylock (1/2 Jam)
4	2	013-5020-00	5/8" Nut
5	2	070-8001-00	72" Inner Suspension Cage
5A	2	070-8000-00	60" Inner Suspension Cage
6	8	018-5600-00	1/2" x 1 1/2" Hex Bolt
7	8	019-5007-00	1/2" Lock Washer
8	2	024-6034-00	Grease Fitting
9	4	032-5051-00	Shoulder Spacer
10	8	032-6033-00	3/4" Brass Bushing
11	8	019-5702-00	1/2" Flat Washer Gr 8
12	4	072-1000-98	Isolator Band Clamp (35HP Diesel Only)



Diesel Tanks

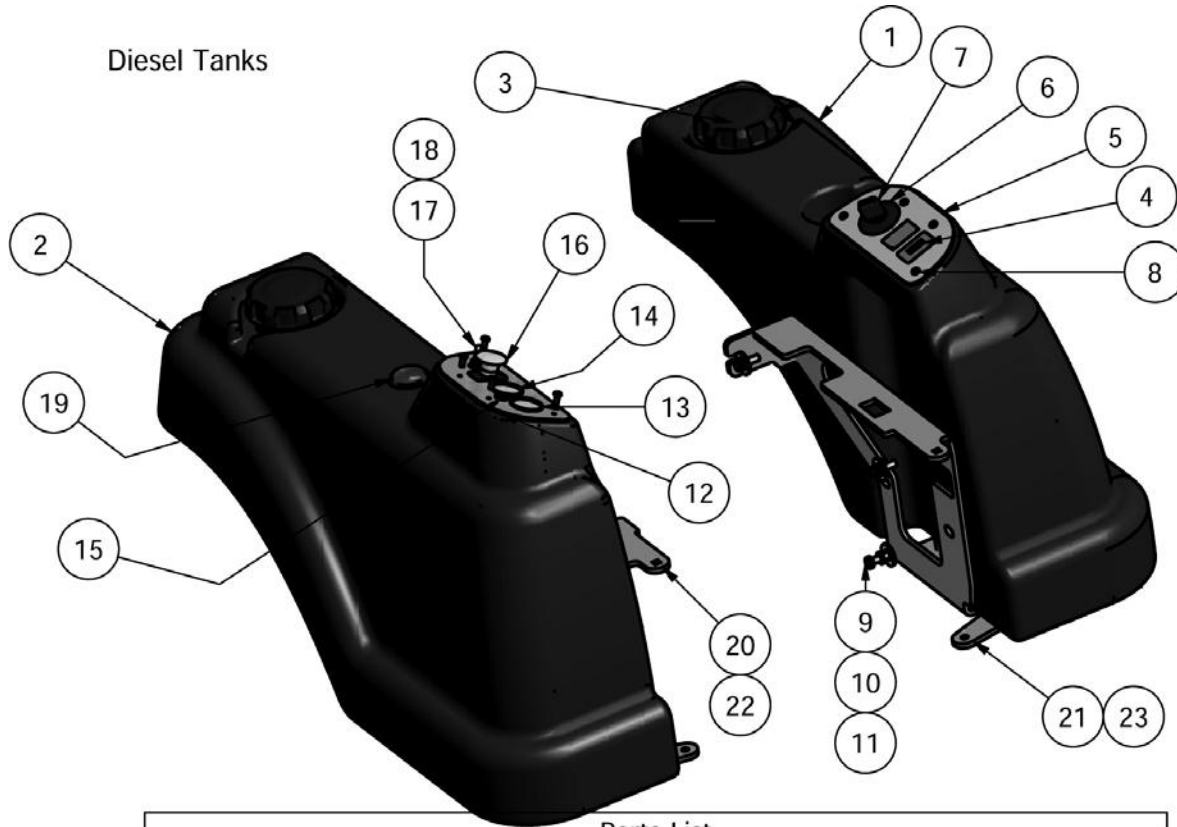

Parts List

ITEM	QTY	PART NUMBER	DESCRIPTION
1	1	067-3000-00	Left Fuel Tank
2	1	067-3001-00	Right Fuel Tank
3	2	066-8090-00	Diesel Fuel Cap
4	1	083-4014-00	Hourmeter-Diesel
5	1	079-3402-00	Control Panel (Left)
6	1	077-8076-00	Ignition Switch
7	1	042-9000-00	Ignition Key
8	8	018-5301-00	10mm x 32 x 1" Bolt
9	10	018-5015-00	5/16" x 1" Hex Bolt
10	10	019-8051-00	5/16" Lock Washer
11	10	019-8044-00	5/16" Flat Washer
12	1	079-3403-00	Diesel Control Panel (Right)
13	1	086-5001-00	Oil Gauge with Sender
14	1	086-5000-00	Temperature Gauge with Sender
15	1	089-1000-00	Oil Light
16	1	056-8058-00	PTO Engager
17	1	078-8077-00	Deck Lift Joystick
18	1	014-8077-00	Joystick Cover
19	1	067-4025-00	Fuel Gauge and Grommet
20	1	031-2007-00	Tank Support-Left (60")
21	1	031-2006-00	Tank Support-Right (60")
22	1	031-2010-00	Tank Support-Left (72")
23	1	031-2011-00	Tank Support-Right (72")



Deck Spindle

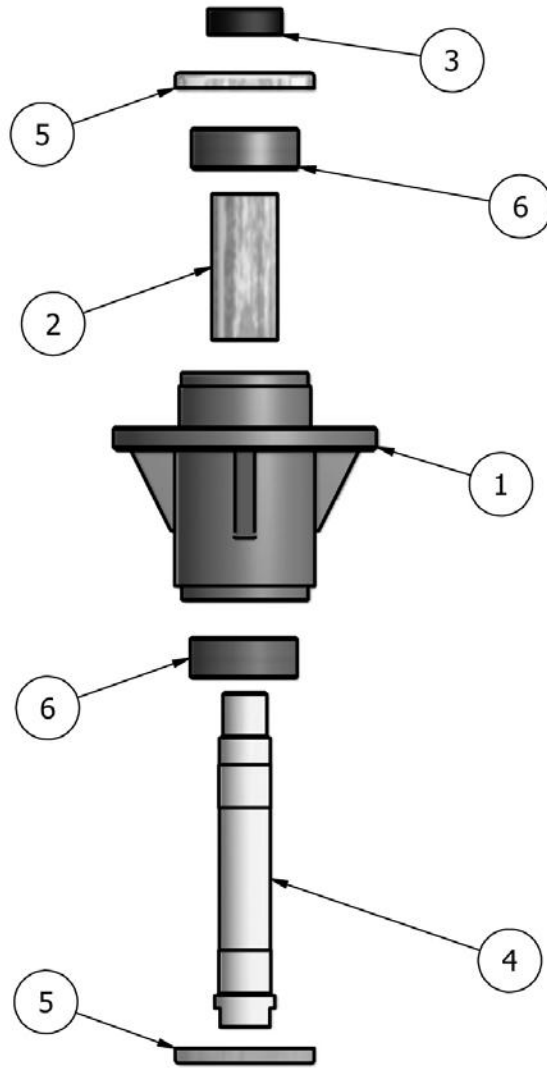

Parts List			
ITEM	QTY	PART NUMBER	DESCRIPTION
1	1	037-8005-00	Spindle Housing
2	1	037-8003-00	Spindle Spacer
3	1	037-9050-00	Spindle Collar
4	1	037-6019-00	Spindle Shaft
5	2	037-8002-00	Bearing Cover
6	2	037-8001-00	Bearing
7	3	037-8000-00	Complete Double Bearing Assembly



Diesel Engine

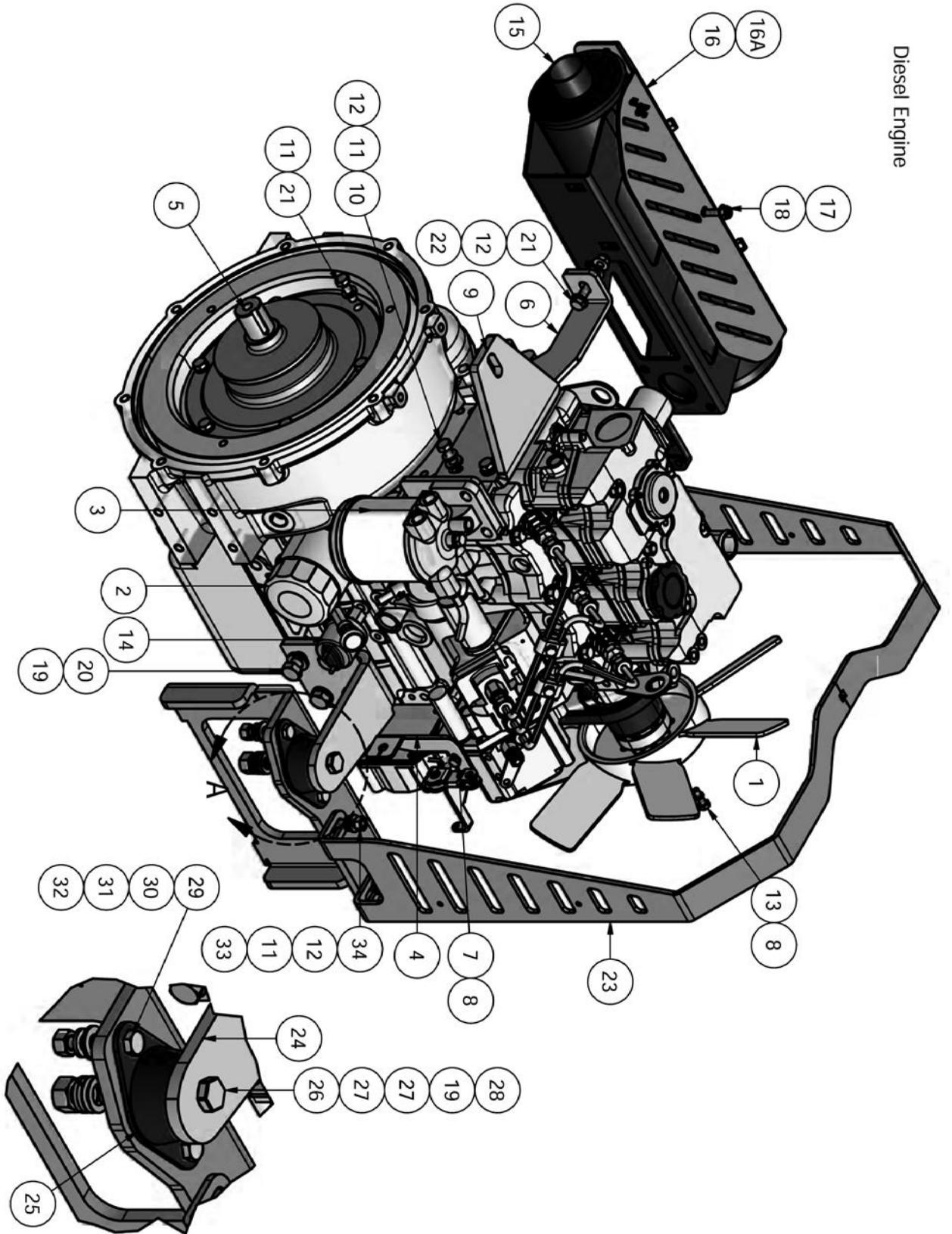

DETAIL A



Parts List			
ITEM	QTY	PART NUMBER	DESCRIPTION
1	1	015-6050-00	Diesel Fan
2	1	063-2010-00	Cat Oil Filter
3	1	063-2011-00	Fuel Filter
4	1	039-1010-00	Diesel Throttle Bracket (4 Tier)
5	1	017-3000-00	Stub Shaft
6	1	039-1020-00	Diesel Muffler Hanger Bracket
7	2	018-2002-00	6 mm x 10 mm Hex Bolt
8	6	019-4008-00	1/4" Lock Washer
9	1	201-8005-00	Rear Motor Mount for Diesel
10	2	018-2001-00	M8 x 1.25 x 25mm Hex Head Bolt
11	14	019-8051-00	5/16" Lock Washer
12	10	019-8044-00	5/16" Flat Washer
13	4	018-2000-00	6mm x 20mm Bolt
14	1	086-5001-00	Oil Pressure Guage with Sender
15	1	015-0005-00	Diesel Muffler
16	1	043-1010-00	Diesel Muffler Guard (28hp)
16A	1	043-1000-00	Diesel Muffler Guard (35hp)
17	3	030-8000-00	1/4" x 3/4" Set Screw
18	3	013-9001-00	1/4" Flange Nut
19	10	019-5007-00	1/2" Lock Washer
20	8	018-6022-00	12mm Bolt- Diesel
21	7	018-2007-00	5/16" x 1" Bolt
22	1	013-8049-00	5/16-18 Nylock Flange Nut
23	1	201-8001-00	Hood Holder Diesel
24	2	201-8008-00	Diesel Motor Side Support
25	2	032-4050-00	Rubber Isolator
26	2	018-7016-00	1/2" x 3" Hex Bolt
27	4	019-5010-00	1/2" Brass Washer
28	2	013-7018-00	1/2" Hex Nut
29	4	018-6049-00	3/8" x 1" Hex Bolt
30	4	019-5029-00	3/8" Flat Washer
31	4	019-5037-00	3/8" Lock Washer
32	4	013-6014-00	3/8" Hex Nut
33	4	018-5025-00	5/16" x 1 1/4" Hex Bolt
34	4	013-8043-00	5/16" Nut



Radiator

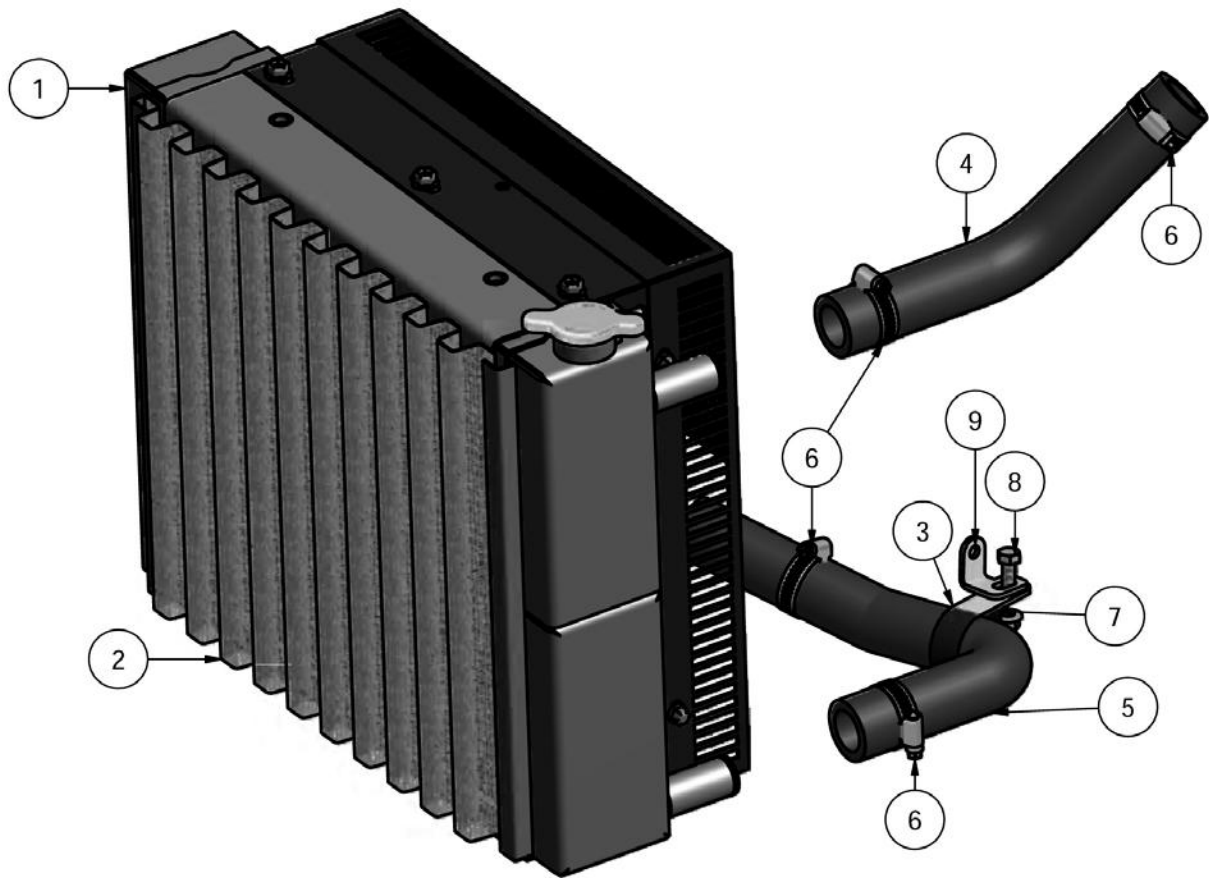

Parts List			
ITEM	QTY	PART NUMBER	DESCRIPTION
1	1	061-5000-00	Radiator- 28hp & 35hp Diesel Models
2	1	094-5088-00	Radiator Screen-Diesel
3	1	072-8090-00	Diesel Clamp 1 3/4" Vinyl
4	1	051-3000-00	Top Radiator Hose for Diesel
5	1	051-3001-00	Bottom Radiator Hose for Diesel
6	4	072-2003-00	1 1/8" Hose Clamp
7	1	013-9002-00	5/16" Flange Nut
8	1	018-6083-00	5/16" x 3/4" Hex Bolt
9	1	039-1015-00	Diesel Radiator Hose Clamp Bracket

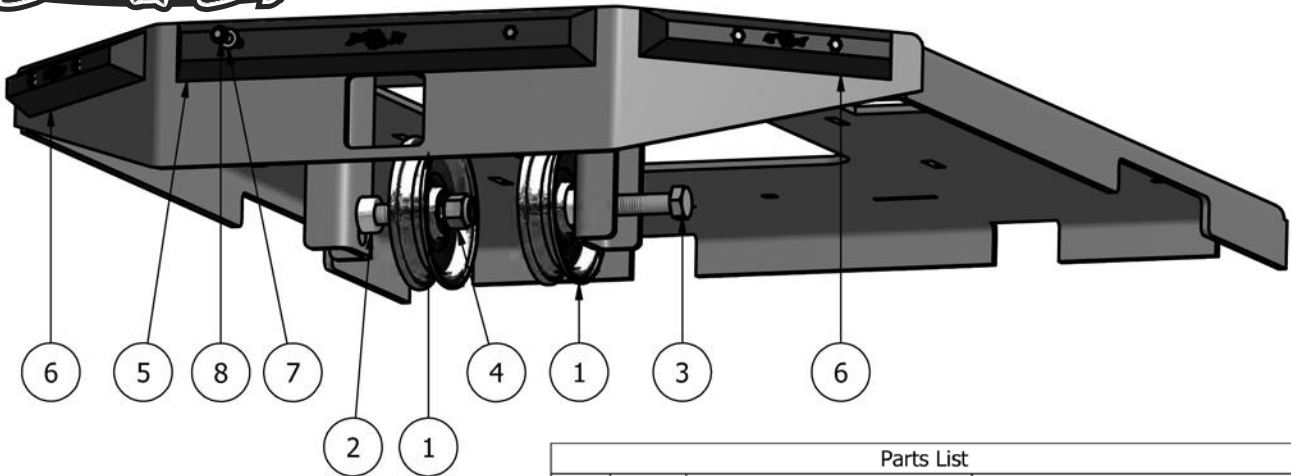

Parts List			
ITEM	QTY	PART NUMBER	DESCRIPTION
1	2	033-7025-00	5" V Idler Pulley
2	2	025-7020-00	5/8" x 1/2" Collar Spacer
3	2	018-6059-00	5/8" x 2 1/2" Bolt
4	2	013-7021-00	5/8" Nylock Nut
5	1	029-7037-00	14" Bumper
6	2	029-7038-00	8" Bumper
7	6	019-7040-00	1/4" Flat Washer
8	6	030-7039-00	1/4" x 1 1/2" Self Tapping Screw

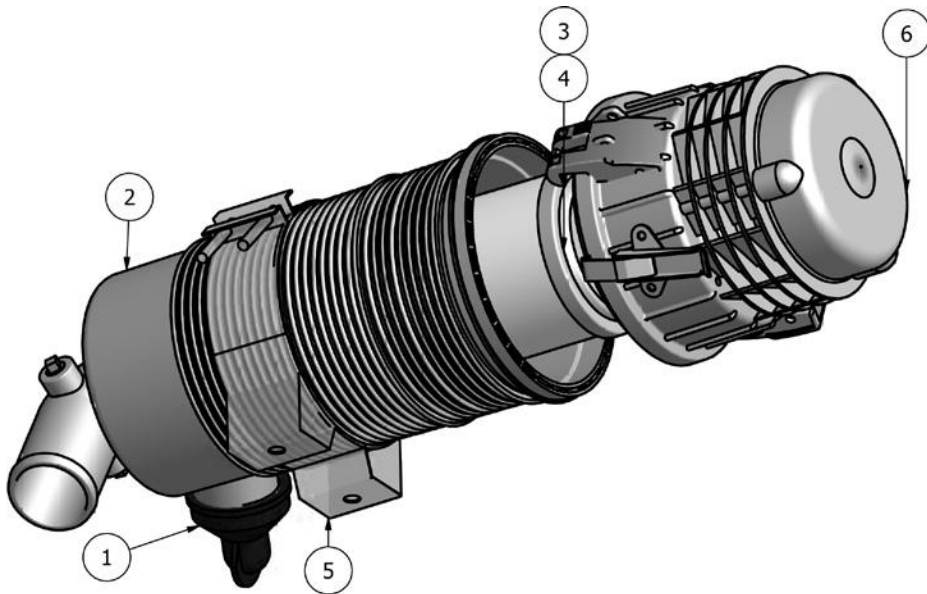

Parts List			
ITEM	QTY	PART NUMBER	DESCRIPTION
1	1	088-1020-00	Debris Plug
2	1	088-1018-00	Canister Body
3	4	063-2060-00	Inner Filter
4	4	063-2050-00	Outer Filter
5	3	088-1019-00	Mounting Bracket
6	1	088-1017-00	Filter Cap
7	1	088-1010-50	Complete Unit



60" Deck

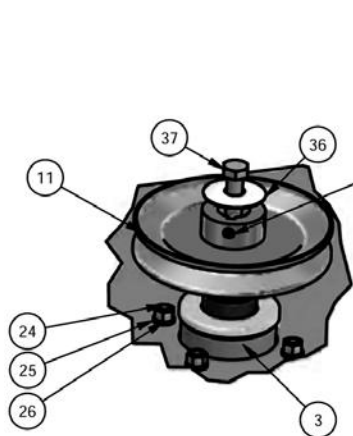
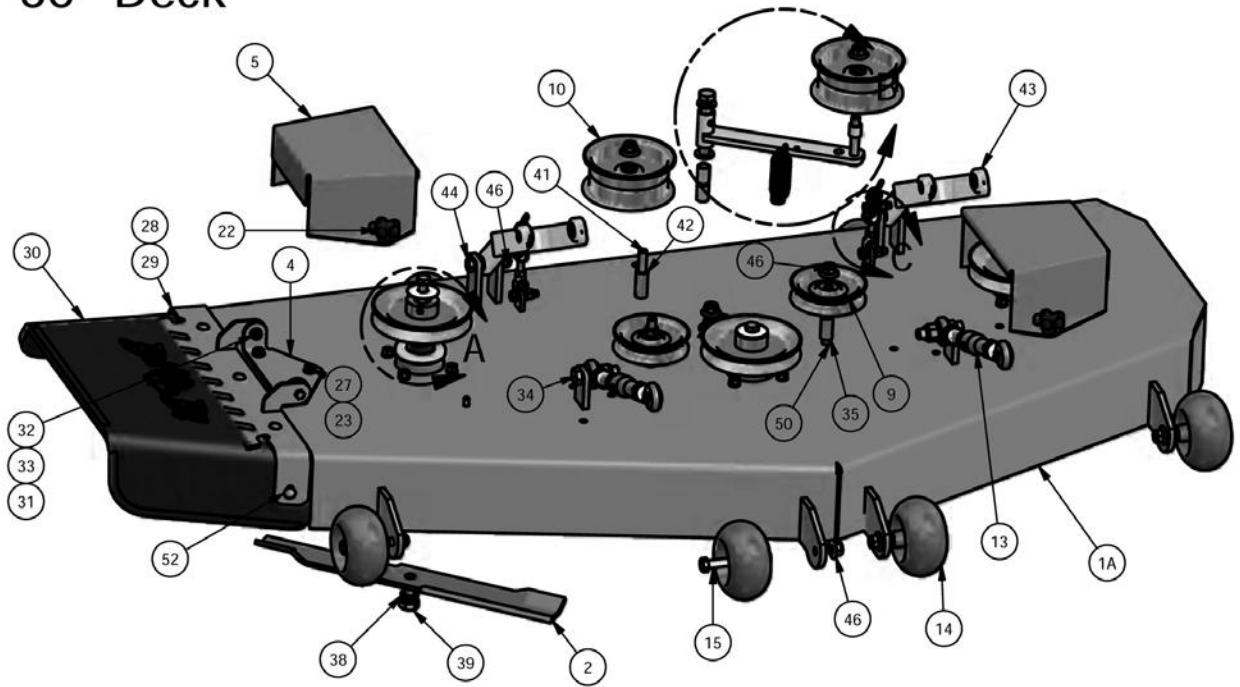

DETAIL A

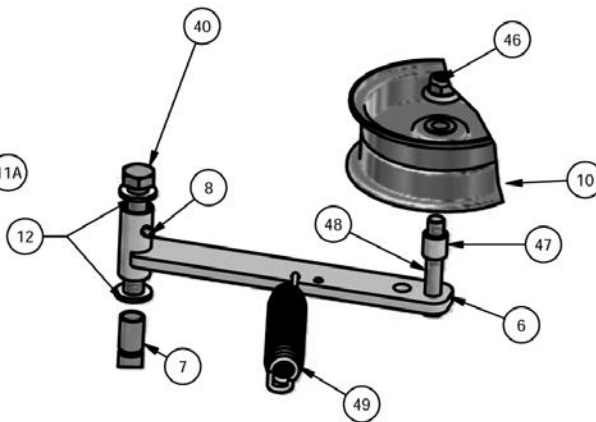

DETAIL B

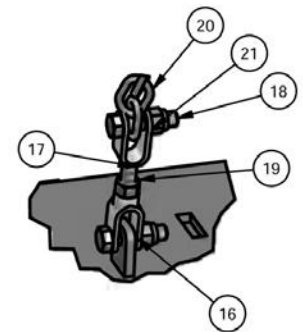

DETAIL C

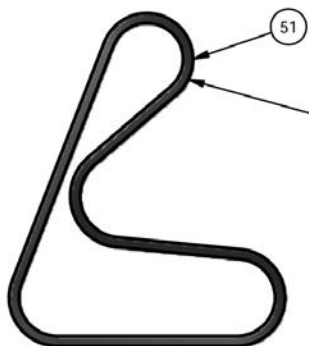

60" Deck Belt

041-1650-00 All Pup & Lightning

041-2375-00 35HP Diesel

041-0222-00 28HP Diesel

041-0219-00 27HP Kawasaki & 35HP Briggs AOS



60" Deck Parts List			
ITEM	QTY	PART NUMBER	DESCRIPTION
1	1	060-5403-98	60" Deck Complete Assembly with Spindles
1A	1	060-5403-00	60" Deck Shell Only
2	3	038-6060-00	60 Inch Fusion Blade
3	3	037-8000-00	Double Bearing Spindle Assembly
4	1	206-6017-00	Discharge Chute Hanger
5	2	014-6010-00	Plastic Pulley Cover
6	1	039-6945-00	Deck Idler 2009
7	2	032-6033-00	5/8 x 1 1/8" Brass Bushing
8	1	024-6034-00	1/4 Drive-in Grease Fitting
9	2	033-6001-00	4 3/4" Idler Pulley
10	2	033-5001-00	5 3/4" Deck Idler Pulley
11	3	033-6004-00	6 1/4" Drive Pulley
11A	1	030-0050-00	5/16" Set Screw
12	2	019-6017-00	.635 ID Plastic Washer
13	2	048-6056-00	Turnbuckle (Top Link)
14	6	022-5234-00	Anti-Scalp Rollers
14A	6	022-5234-98	Anti-Scalp Rollers Complete Assembly
15	6	018-5019-00	1/2" x 4" Bolt (Grade 8)
16	2	046-6044-00	Female Yoke
17	2	046-6048-00	Male Yoke
17A	2	046-6048-98	4" Yoke & Chain Complete Assembly
17B	2	046-6047-98	3" Yoke & Chain Complete Assembly
18	4	018-6012-00	3/8" x 1 1/2" Hex Bolt
19	2	013-6014-00	3/8" Hex Nut
20	2	047-6048-98	4" Chain Assembly Lightning, AOS & Diesel
21	4	013-5041-00	3/8 Nylock Nut
21A	2	047-6047-98	3" Chain Assembly PUP (Only)
22	4	045-6043-00	5/16" Knob
23	3	018-5250-00	3/8" x 3/4" Hex Bolt
24	12	018-5040-00	3/8" x 1 1/4" Hex Bolt
25	12	019-5037-00	3/8" Lock Washer
26	12	013-6014-00	3/8" Hex Nut
27	3	013-5201-00	3/8" Flange Nut
28	1	039-4863-00	60" Lower Hanger
29	1	039-4864-10	60" Discharge Chute Upper Hanger Plate
30	1	210-6005-00	Rubber Discharge Chute
31	2	019-6042-00	.360 ID Plastic Washer
31A	1	210-6004-00	Complete Assembly Rubber Discharge Chute
32	2	018-5015-00	5/16" x 1" Hex Bolt
33	7	013-8049-00	5/16" Nylock Flange Nut
34	2	018-6059-00	5/8" x 2 1/2" Hex Bolt
35	2	025-5338-00	Pup Pulley Spacer
36	3	019-6019-00	Cup Washer
37	3	018-5600-00	1/2" x 1 1/2" Hex Bolt
38	3	019-4807-00	5/8" Lock Washer
39	3	018-6020-00	5/8-18 x 1 1/2 GR 8 Hex Bolt
40	1	018-5311-00	5/8" x 4" Hex Bolt
41	1	018-6054-00	1/2-13 x 3 1/2 GR 5 Hex Bolt
42	1	025-5339-00	1 3/4" Pulley Spacer
43	2	031-6010-00	Deck Arm Assembly
44	2	018-6036-00	1/2" x 2 1/2" Hex Bolt
45	2	013-5300-00	1/2" Flange Nut
46	14	013-8050-00	1/2-13 Nylon Flange Nut-Orange
47	1	025-5203-00	3/4 OD x 1/2 ID x 3\4 Length
48	1	018-7016-00	1/2 x 3" Bolt
49	1	034-2009-00	Deck Idler Spring
50	2	018-2018-00	1/2 x 3 1/2 Flange Bolt Grade 8
51	1	041-1650-00	Deck Belt All Pup & Lightning
51A	1	041-2375-00	Deck Belt 35HP Diesel
51B	1	041-0222-00	Deck Belt 28HP Diesel
51C	1	041-0219-00	Deck Belt 27HP Kawasaki & 35HP Briggs AOS
52	5	018-4703-00	5/16" x 1 1/4" Carriage Bolt

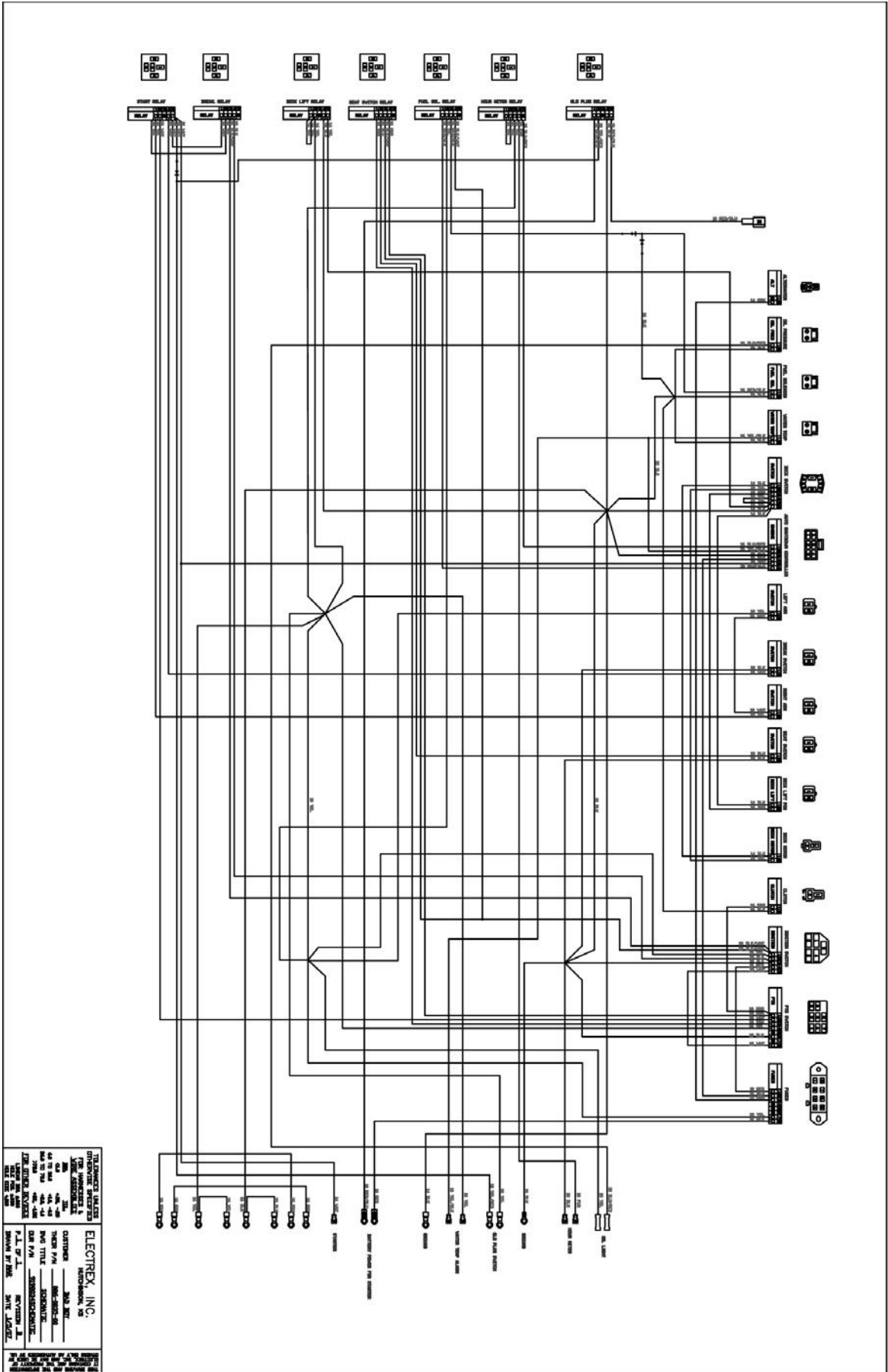

THE LARGEST SELECTION OF SERVICE PARTS		ELECTREX, INC.	
TYPE: _____		MIDDLETOWN, VA	
PART NO.: _____		CUSTOMER: _____	
DATE: _____		PHONE: _____	
QUANTITY: _____		FAX: _____	
NAME: _____		ELECTREX, INC.	
ADDRESS: _____		P.O. BOX 1	
CITY: _____		MIDDLETOWN, VA	
STATE: _____		22644	
COUNTRY: _____		USA	
TELEPHONE: _____		703/554-1111	
FAX: _____		703/554-1112	
E-MAIL: _____		ELECTREX@AOL.COM	
WEBSITE: _____		WWW.ELECTREX.COM	



Technical Support:

James Russell Extension 6638
Bill Hurst (bill@badboymowers.com)..... Extension 6617
Brad Covington..... Extension 6648

Warranty:

Dustin Tissiere (dustin@badboymowers.com) Extension 6613
Bill Hurst (bill@badboymowers.com)..... Extension 6617

Parts:

Brad Foree (brad@badboymowers.com) Extension 6637
Robert Patterson (robert.patterson@badboymowers.com)..... Extension 6649

For additional information, please see us at
www.badboymowers.com

Bad Boy, Inc.
102 Industrial Drive
Batesville, Arkansas 72501
(870) 698-0090