

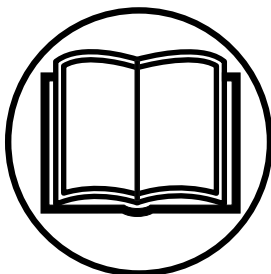

OPERATOR'S MANUAL

Bad Boy 21" Push Mower

Model:
BB21 Zone Start - Kawasaki

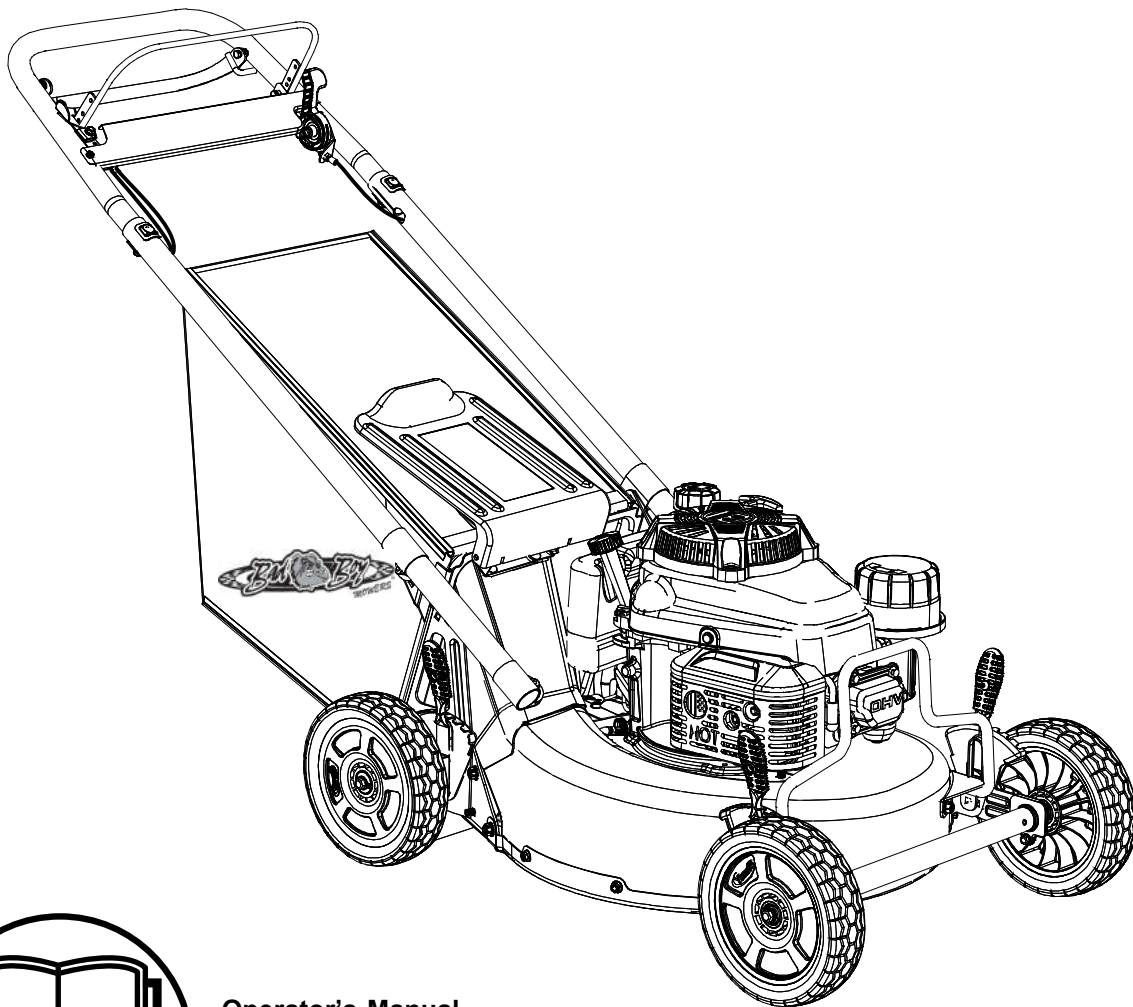

Operator's Manual

Read these instructions carefully and make sure you understand them before using the Bad Boy Push Mower.

INTRODUCTION



Careless or improper use of this Lawn Mower can cause serious or even fatal injury. Carefully read, understand and follow ALL instructions in this manual as well as the instructions in the included Owner's Manual for the engine before using the Bad Boy Push Mower.

Allow only competent adults to operate this lawn mower. It is the owner's responsibility to ensure that all operators of this mower have read and understand the content of this manual.

Common sense:

The focus of this manual is HOW to operate and service the equipment safely. It is not possible to cover every conceivable situation you can face when using this mower. Therefore use this product only in a manner described in this manual. **Operation or handling the machine in any other manner can lead to serious injury or death.** If a situation is not described in this manual it should be considered dangerous - and not be done.

If you are unfamiliar with this product make sure that you carefully understand how it functions and practice all operations and handling before putting the machine to use. Familiarize yourself in the presence of an experienced operator. Avoid all situations that are beyond your capability.

If you still feel uncertain about the operating procedures after reading these instructions DO NOT operate the machine until you have consulted an experienced operator.

If you have further questions you can contact - **Bad Boy Mowers**, by writing or calling, see information below. **Bad Boy Mowers**, will willingly be of service and provide you with advice as well as help you to use your product both efficiently and safely.

Bad Boy Inc
102 Industrial Dr
Batesville, AR 72501
USA

Toll Free no: (866)
Fax no: (870)

622-3269
698-2123

PERSONAL SAFETY EQUIPMENT

When working and operating garden equipment - approved personal safety items should be used:



Hearing
Protection



Eye
Protection



Protective
Gloves



Protective
Shoes



WARNING

CALIFORNIA Proposition 65 Warning

The engine exhaust from this product contains chemicals known to the State of California to cause cancer, birth defects or other reproductive harm.

NOTICE

The engine is not equipped with a spark arrester in the muffler. It is a violation of California Public Resource Code Section 4442 to use or operate the engine on any forest-covered, brush-covered, or grass-covered land. Other states or federal areas may have similar laws. Be aware of local laws and regulations.

SAFETY DEFINITIONS

In this manual a Safety Alert Symbol  followed by the signal words WARNING and CAUTION are used to identify safety information about hazards which can result in death, serious injury and/or property damage.

These signal words mean:

 **WARNING** indicates a hazard which, if not avoided, **could result in death or serious injury.**

 **CAUTION** indicates a hazard which, if not avoided, **might result in minor or moderate injury.**

NOTICE indicates a message not related to personal injury.

SAFETY HAZARDS

 WARNING
--

DO NOT MODIFY THE PRODUCT

Under no circumstances may the design of the machine be modified without the permission of the manufacturer. Always use genuine parts and accessories. Unauthorized modifications, parts and/or accessories can result in serious personal injury or the death of the operator or others. Your warranty may not cover damage or liability caused by the use of unauthorized accessories or replacement parts.



WARNING

ASPHYXIATION HAZARD

Running an engine in a confined or badly ventilated area can result in injury or death due to asphyxiation or carbon monoxide poisoning.



CAUTION

HEARING HAZARD

During the normal use of this machine, operator may be exposed to a noise level equal to or higher than 85 dB(A). Use hearing protection.

REGISTER THE PRODUCT

Please register your new Bad Boy Push Mower by mailing in a copy of this page together with a copy of your mower invoice/receipt.

Registration will allow us to contact you in case of any critical updates or recalls on this machine. Product registration has been found helpful in tracking stolen equipment.

Record the following information for your records:

PURCHASE DATE: _____

Dealership Purchase From: _____

MODEL No: _____

SERIAL No: _____

ENGINE MODEL: _____ ENGINE TYPE: _____ ENGINE SERIAL No: _____

The lawn mower model and serial number as well as the engine model number, engine type and serial number are critical in order to obtain the correct service parts. All engine parts are distributed through the Kawasaki engine dealer networks. Please refer to the engine Owner's Manual that was included with the mower.

Mail information:

Street Address: _____

Name: _____

City, State, Zip code: _____

Phone Number: _____

Email Address: _____

CONTENTS

Content	Page
Introduction, personal safety	2
General safety message.....	2-3
Registration of the product	3
Table of contents	4
Lawn mower safety.....	4-5
Decals and locations.....	6
What is what on the product.....	6
Assembly - setup	7-9
Recommended engine oil	8
Recommended fuels.....	10
Fuel and fuel safety warnings.....	10
Controls and operation	10-11
Maintenance	12-13
Maintenance schedule.....	12
Blade maintenance	13
Oil change.....	13
Warranty	15



WARNING

In order to prevent accidental starting when setting up, transporting, adjusting or making repairs, always disconnect spark plug wire and place wire where it can not come in contact with the plug.



WARNING

Always secure the mower when unattended. Never leave the mower in such way that an unauthorized person can operate or move the mower.

LAWN MOWER SAFETY

SAFETY PRACTICES FOR WALK-BEHIND MOWERS

This lawn mower is capable of amputating hands and feet and throwing objects. Failure to observe the following safety instructions could result in serious injury or death.

I. GENERAL OPERATION

1. Read, understand, and follow all instructions on the machine and in the manuals before starting.
2. Do not put hands or feet near or under the machine. Keep clear of the discharge opening at all times.
3. Only allow responsible adults, who are familiar with these instructions, to operate this machine.
4. Clear the area of objects such as rocks, wire, toys, etc., which could be thrown by the blade. Stay behind the handle when the engine is running.
5. Be sure the area is clear of other people before operating. Stop machine if anyone enters the area.
6. Do not operate machine barefooted or while wearing sandals. Always wear substantial footwear (protective shoes).
7. Do not pull machine backward unless absolutely necessary. Always look down and behind before and while moving backward.
8. Keep the operating area clear of bystanders. Stop the blade when crossing gravel surfaces.
9. Do not operate machine without the entire grass catcher, or mulch plug and discharge door, rear guards, or other safety protective devices in place and working.
10. Never leave a running machine unattended.
11. Stop the engine and wait until the blade comes to a complete stop before cleaning the machine, removing grass catcher, or unclogging the discharge chute.
12. Operate machine only in daylight or good artificial light.
13. Do not operate machine while under the influence of alcohol or drugs.
14. Never operate mower in wet grass. Always be sure of your footing - walk - never run.
15. Disengage the drive system, before starting the engine.
16. If the machine should start to vibrate abnormally, stop the engine and check for the cause immediately. Vibration is generally a warning of trouble.
17. Always wear approved personal safety equipment such as hearing protection, eye protection, and protective gloves when operating machine.
18. See manufacturer's instructions for proper operation and installation of accessories. Only use accessories approved by Bad Boy Mowers or the engine manufacturer.

LAWN MOWER SAFETY

II SLOPE OPERATION

Slopes are a major factor related to slip and fall accidents, which can result in severe injury. Operation on all slopes requires extra caution. If you feel uneasy on a slope, do not mow it.

1. Mow across the face of slopes; never up and down. Exercise extreme caution when changing direction on slopes.
2. Watch for holes, ruts, bumps, rocks, or other hidden objects. Uneven terrain could cause a slip and fall accident. Tall grass can hide obstacles.
3. Do not mow on wet grass or excessively steep slopes. Poor footing could cause a slip and fall accident.
4. Do not mow near drop-offs, ditches, or embankments. You could lose your footing or balance.

III. CHILDREN

Tragic accidents can occur if the operator is not alert to the presence of children. Children are often attracted to the machine and the mowing activity. Never assume that children will remain where you last saw them.

1. Keep children out of the mowing area and under the watchful care of a responsible adult other than the operator.
2. Be alert and turn mower off if a child enters the area.
3. Never allow children to operate the machine.
4. Use extra care when approaching blind corners, shrubs, trees, or other objects that may block your view of a child.

IV. SAFE HANDLING OF GASOLINE:

To avoid personal injury or property damage, use extreme care in handling gasoline. Gasoline is extremely flammable and the vapors are explosive.

1. Extinguish all cigarettes, cigars, pipes, and other sources of ignition.
2. Use only an approved gasoline container.
3. Never remove gas cap or add fuel with the engine running. Allow engine to cool before refueling.
4. Never refuel the machine indoors.
5. Never store the machine or fuel container where there is an open flame, spark, or pilot light such as on a water heater or on other appliances.
6. Never fill containers inside a vehicle or on a truck or trailer bed with a plastic liner. Always place containers on the ground away from your vehicle before filling.
7. Remove the mower from the truck or trailer and refuel it on the ground. If this is not possible, then refuel the mower with a portable container, rather than from a gasoline dispenser nozzle.

Continued,

8. Keep the nozzle in contact with the rim of the fuel tank or container opening at all times until fueling is complete. Do not use a nozzle lock-open device.
9. If fuel is spilled on clothing, change clothing immediately.
10. Never overfill fuel tank. Replace gas cap and tighten securely.

V. GENERAL SERVICE

1. Never operate the mower in a closed area.
2. Keep all nuts and bolts tight to be sure the mower is in safe working condition.
3. Never tamper with safety devices. Check their proper operation before each use of the mower.
4. Keep the mower free of grass, leaves, or other debris build-up. Clean up oil or fuel spillage and remove any fuel-soaked debris. Allow machine to cool before storing.
5. If you strike a foreign object, stop and inspect the mower. Repair, if necessary, before starting.
6. Never make any adjustments or repairs with the engine running. Disconnect the spark plug wire and ground against engine to prevent unintended starting.
7. Never attempt to make wheel height adjustments while the engine is running.
8. Check grass catcher components and the rear discharge door frequently and replace only with Bad Boy Mowers original parts when necessary.
9. Mower blades are sharp. Wrap the blade or wear gloves, and use extra caution when servicing them.
10. Do not change engine governor setting or over speed the engine.
11. Maintain or replace all safety and instruction labels.

CAUTION

Muffler and other engine parts become extremely hot during operation and remain hot after engine has stopped. To avoid severe burns on contact, stay away from these areas.



DECALS AND LOCATIONS

These labels warn you of potential hazards that can cause serious injury. Carefully read and understand them. If a label comes off or becomes hard to read, contact **Bad Boy Mowers** immediately for replacement.

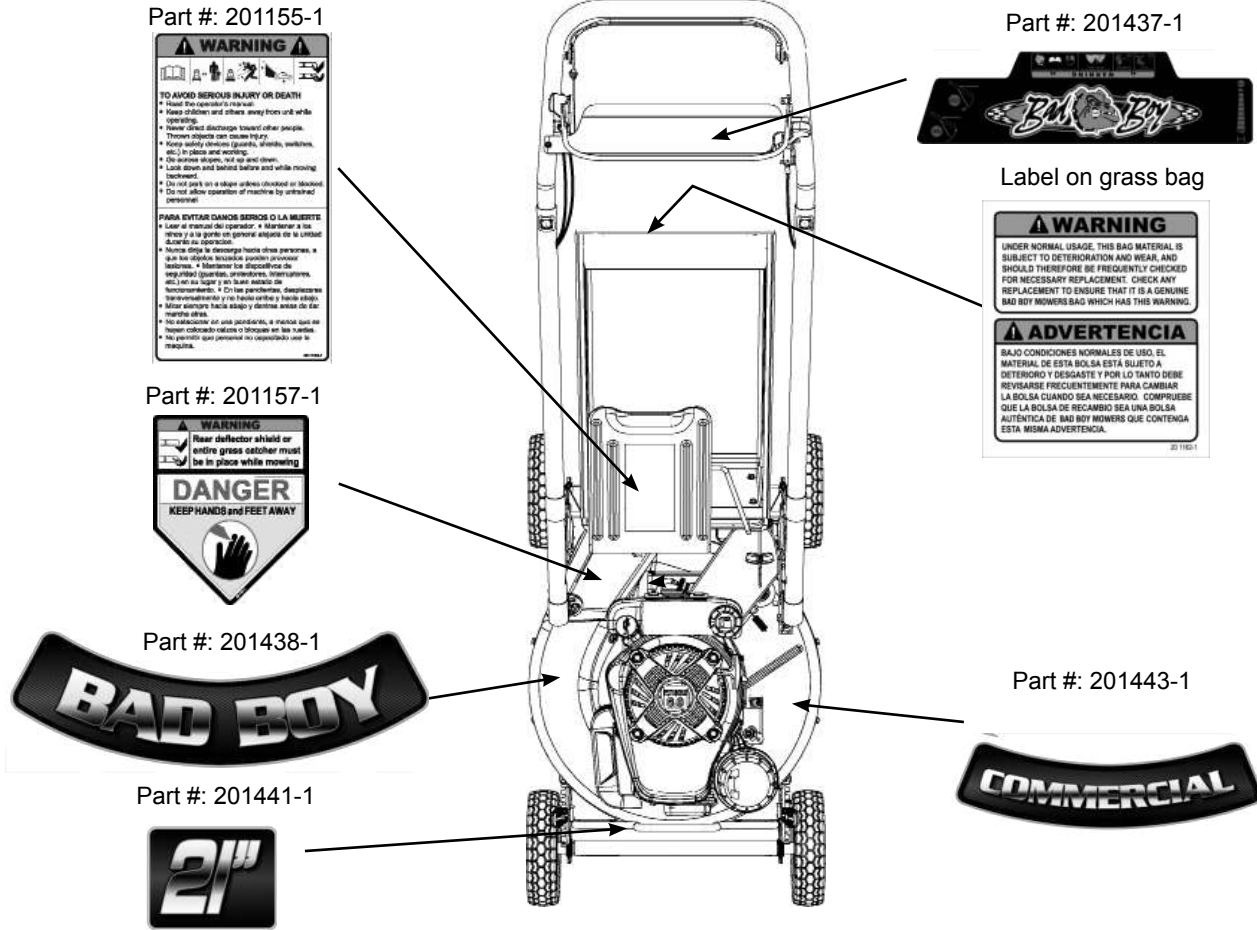

Part #: 201155-1



Part #: 201437-1



Label on grass bag



Part #: 201157-1



Part #: 201438-1



Part #: 201443-1



Part #: 201441-1



WHAT IS WHAT

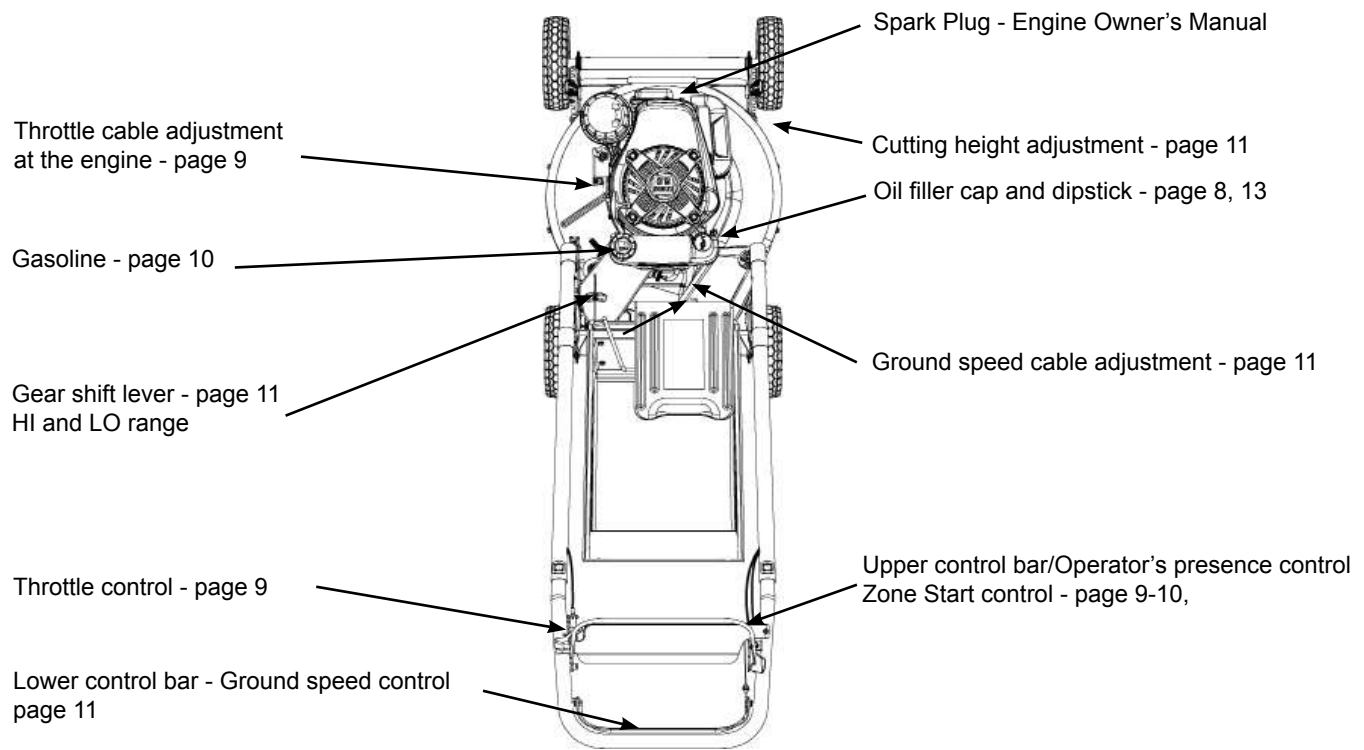

ASSEMBLY - SETUP

UNPACKING:

Carefully remove the mower from its packaging and check that you have all the following items:

Upper Handle complete
(2) Lower Handle tubes
Mower Bag and Mulch Plug (installed on the mower)
Engine Owner's Manual and Warranty Statement
BB21 Operator's Manual.

NOTICE:

If you are missing any of these items or if you are unsure of how to properly assemble this mower please contact **Bad Boy Mower** by phone: **(866) 622-3269**

Tools needed for assembly:
2 pcs 10mm wrenches
1 pcs 13mm wrench
1 pcs Needle nose pliers

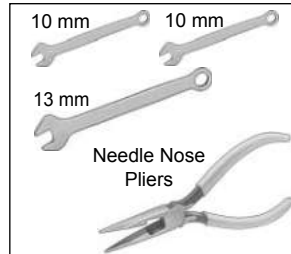

STEP 1

Install the black handle tubes to the mower with the M8 carriage bolts. Do not tighten the nuts. Please note that there are three holes for the upper clamp. We suggest to install the bolt in the center hole as a start.

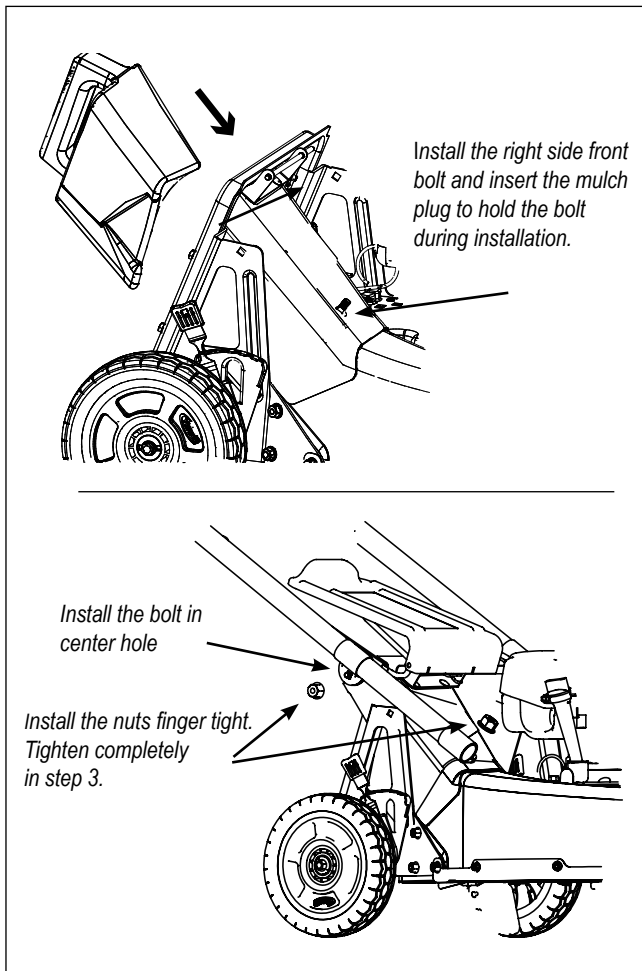

STEP 2

Slide the upper handle assembly into the two lower tubes. Insert the carriage bolt on the left side and use one square washer on each side of the handle tube (1).

Insert the eyelet screw on the right side (2). Use the eyelet to hold the starter rope and handle for convenient reach on the Zone Start model.

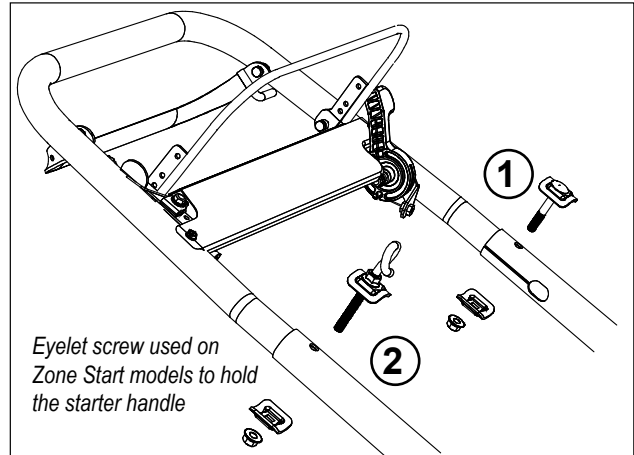

STEP 3

To simplify the alignment of the handle, install the grass catcher.

Tighten the bolts in the following order:

- 1 - Tighten the two bolts on the right side tube clamps.
- 2 - Align the left tube with the catcher (same as the right side) and tighten the two clamps.
- 3 - Tighten the upper bolts that attaches the handle assembly to the tubes.

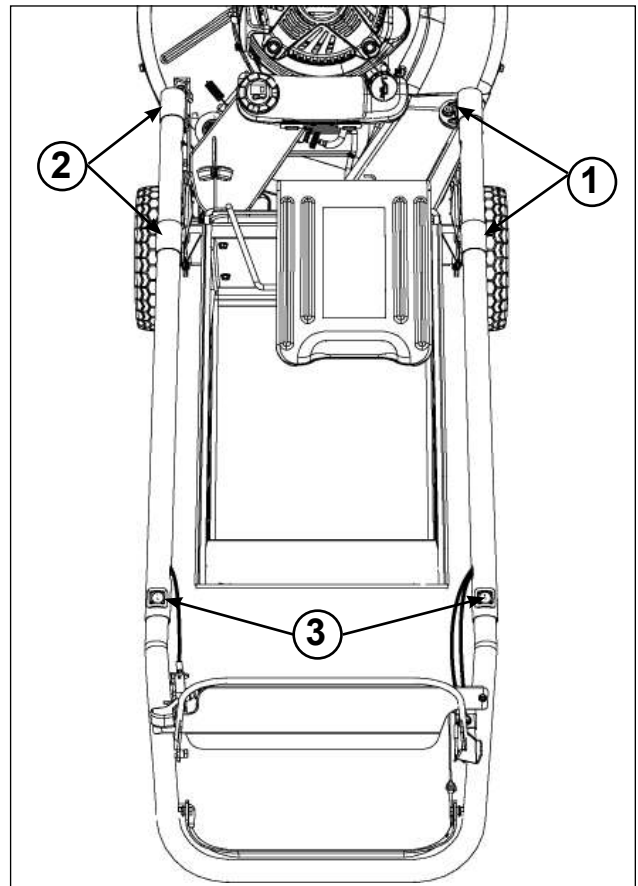

ASSEMBLY - SETUP

STEP 4

Insert the throttle cable inside the left handle tube. Install the cable into the throttle control. The cable has been adjusted at the factory (1) and the nut locked in place. However verify the proper throttle cable adjustment per the instructions of Kawasaki Engines. See "STEP 9".

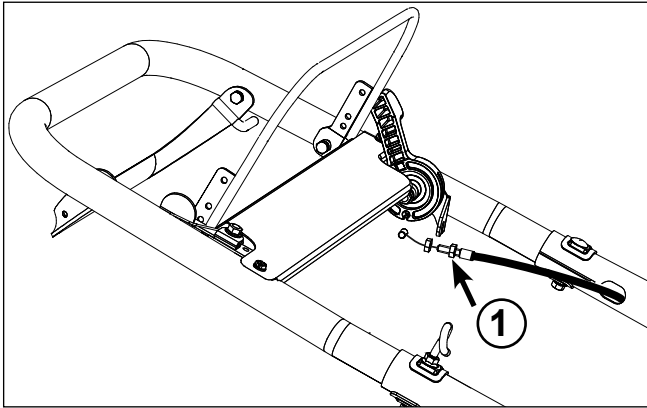

STEP 5

Install the engine control cable in the upper control bar (1). **Note that there are three holes for the control cable - install per the drawing for the proper mower model.** Pull on the cable sheath and insert into the upper hole (2).

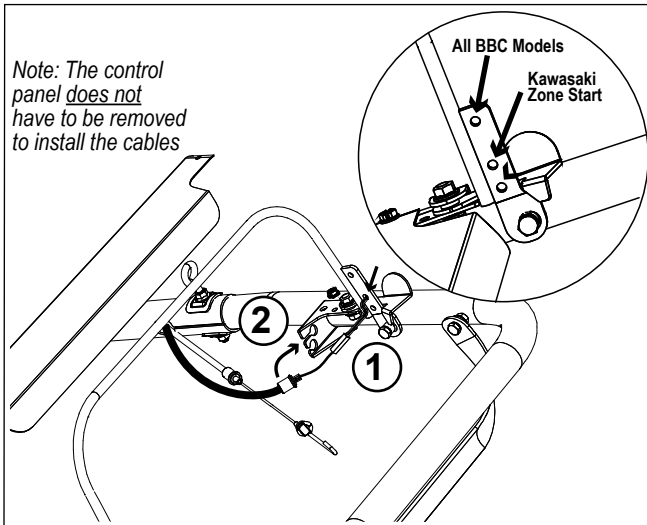

STEP 6

Install the drive cable into the lower control bar (1) and insert the cable sheath fitting into the lower hole of the handle bracket (2).

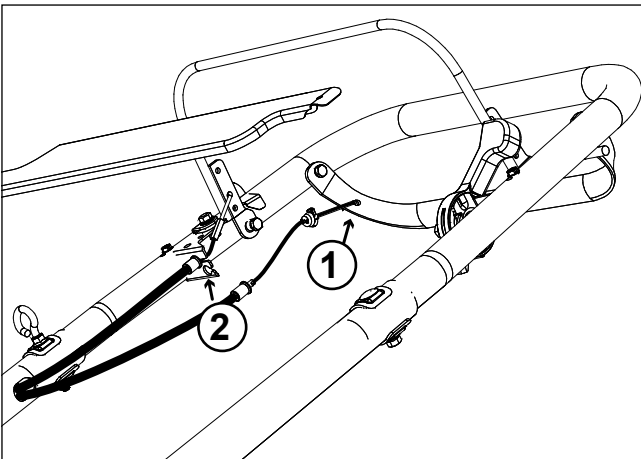

STEP 7 Kawasaki Engine

Fill a new engine with an SAE 10W-30 engine oil.

Fill; 22 Fl.Oz (0.7 Qt. - 0.65 Liters)

If the oil filter is changed the fill volume is;

29 Fl.Oz (0.9 Qt - 0.85 Liters)

Please read the Kawasaki engine Owner's Manual for full information.

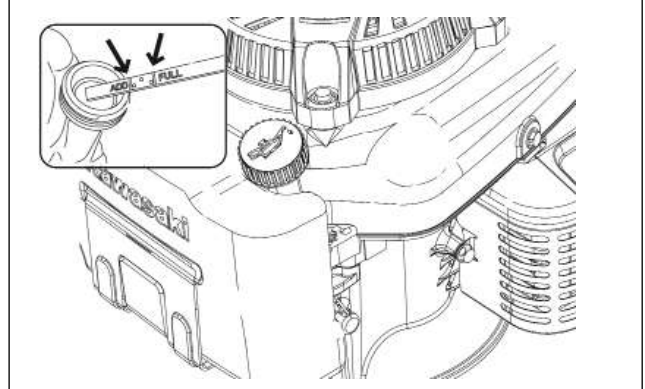

ASSEMBLY - SETUP - ENGINE CONTROLS

Follow these steps to verify proper setup of the mower equipped the KAWASAKI Zone Start engine.

STEP 8

We recommend verifying that proper cable movement is achieved at the engine when operating the upper control bar.

- Depress the upper control bar.
- When the upper control bar is depressed it will release the flywheel brake/stop switch at the engine.
- The cable length is verified at the factory however it is important to understand the function and how to check the adjustment.

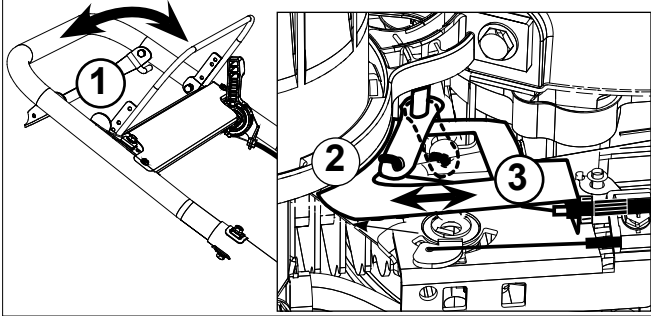

With the control bar in the released position (1) the arm on the engine at (2) should be able to move forward towards its limiter. This position of the arm ensures that the flywheel brake and stop switch stops the engine. When depressing the control bar the stroke of the arm (3) should be a minimum of 7/8" (22 mm) to properly release the engine brake and switch.

STEP 9

Verify that the throttle control is adjusted properly as follows:

- Move the throttle control to the **Choke** position.
- In the Choke position the arm attached to the throttle cable at the engine should bottom out at the arrow (1).
- If needed an adjustment can be made at the throttle control.

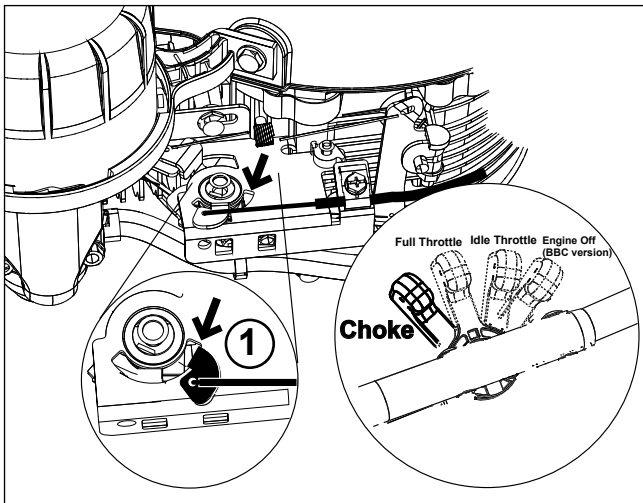

Following these steps for the throttle adjustment will ensure that the Kawasaki engine performs properly for this mower. The engine speed is adjusted to approximately 3200 RPM at the factory.

NOTICE:

The engine speed should preferably be checked and verified with a tachometer. Normal full throttle speed of the engine should be adjusted to 3200 RPM. An authorized Kawasaki Engine Dealer can verify and adjust the engine speed properly.

CONTROLS & OPERATION

STEP 10

Before filling the engine with gasoline - follow all instructions in this manual as well as all instructions provided in the Kawasaki Engine Owner's Manual.

Maximum fill volume:

Kawasaki: 1.9 Qt (1.8 Liter) - 87 octane or higher

The engine will not operate on gasoline marketed as E-85 (85% ethanol)

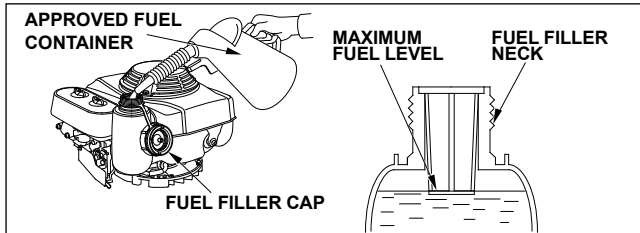

Before operating the mower for the first time, please review and understand the entire manual including all Warnings and Cautions.

Even if you have operated other mowers in the past please take time to become familiar with how this mower works and practice all operations to build up your skills.

BEFORE ANY OPERATION ALWAYS:

- Inspect the mower for any visible damage or broken parts
- Check the oil level in the engine on a daily basis
- Make sure that when you release the Upper Control Bar the engine should stop within three seconds. If the engine does not stop, contact a Bad Boy Mowers Authorized Service Dealer or contact Bad Boy Mower for advice.
- Never operate the mower with obvious damage or malfunction until the problems have been corrected.



WARNING

Never make adjustments or repairs with the engine running. Disconnect the spark plug wire, and keep the wire away from the plug to prevent accidental starting..

STATING THE ENGINE

1. To start a cold engine it is important to use the "Choke" position. To start a warm engine it is not necessary to use the choke.
2. Press down on the upper control bar to release the engine brake and kill switch. If the upper control bar is released during normal operation the engine should stop completely within three seconds.

For best performance use the "Full Throttle" position for all mowing. To verify that the engine is running at full throttle please follow the steps outlined under the setup instructions on pages 7 through 9. A Bad Boy Mowers Authorized Dealer can also verify the correct full throttle adjustment. The engine speed should be adjusted to 3200 rpm.



WARNING

Taking the following precautions will lessen the risk of injury and property damage.

Use extreme care in handling gasoline. Gasoline is extremely flammable and the vapors are explosive.

- Extinguish all cigarettes, cigars, pipes, and other sources of ignition.
- Use only approved gasoline containers.
- Never remove gas cap or add fuel with the engine running.
- Allow engine to cool a minimum of 3 minutes before refueling.
- Never fuel the machine indoors.
- Never store the machine or fuel container where there is an open flame, spark, or pilot light such as on a water heater or other appliances.
- Never fill containers inside a vehicle or on a truck or trailer bed with a plastic liner. Always place containers on the ground away from your vehicle when filling.
- Remove the mower from the truck or trailer and refuel it on the ground. If this is not possible, then refuel the equipment with a portable container, rather than from a gasoline dispenser nozzle.
- Keep the nozzle in contact with the rim of the fuel tank or container opening at all times until fueling is complete. Do not use a nozzle lock-open device.
- If fuel is spilled on clothing, change clothing immediately.
- Never overfill fuel tank. Always wipe off any spilled fuel or oil. Replace fuel cap and tighten.

Notice: The upper control bar is an "Operators Presence Control" on the Zone Start mowers. It has to be pushed down before starting the engine.

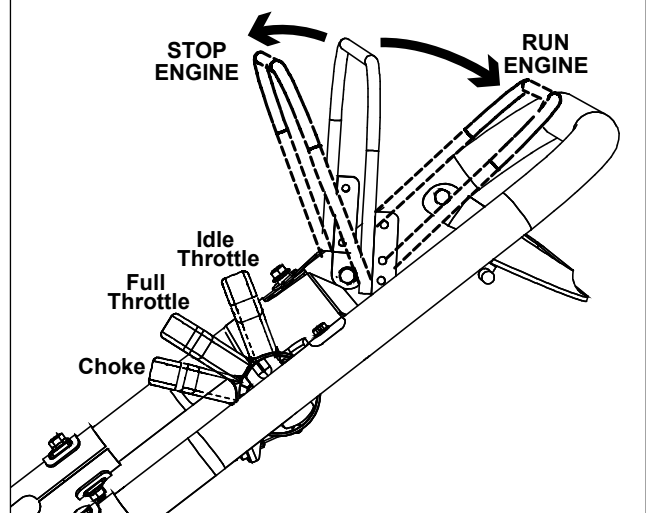

CONTROLS & OPERATION

DRIVE CONTROL

The drive system consists of a two speed transmission and an adjustable belt drive from the engine to the transmission.

The transmission speed can be set to **LO - N - HI**.

HI speed is approximately 4mph - a fast walking speed.

LO speed is approximately 3mph - an average walking speed.

The shifter arm is intentionally made flexible. When the arm is locked in the **LO** or the **HI** position the transmission will automatically mesh into the gears as soon as the drive is engaged by operating the lower control bar.

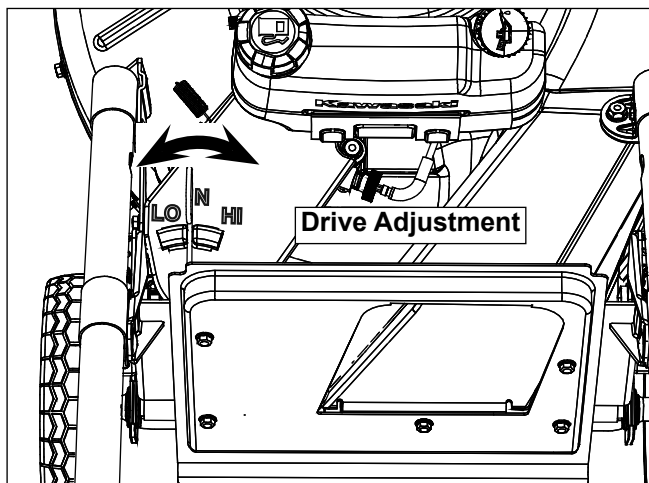

ENGAGING THE DRIVE

To engage and disengage the drive system pull up on the lower control bar (1). Typically the drive will engage when the lower control bar is approximately 1 to 1.5 inches from the handle (2).

Notice

Due to wear, the drive engagement position of the lower control bar can change. If the distance between the lower bar and the handle (2) is less than a 1/4 inch when the mower starts to drive make an adjustment on the red knob located below the engine fuel tank (3).

If needed turn the red knob 2 turns clockwise. Verify the drive position of the control bar by operating the mower. If needed repeat the adjustment.

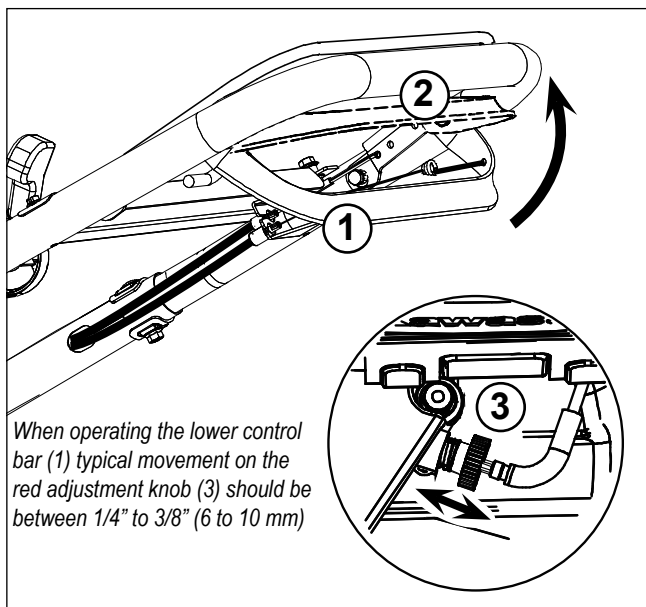

HEIGHT ADJUSTMENT

Each wheel can be adjusted individually to a specific cutting height from 1 inch to 4.5 inch. **Notice: It is only possible to move the adjustment on one side 2 - 3 steps each time.**

Moving the front wheel height adjusters forward raises the cutting height. Moving the rear wheel height adjusters towards the rear of the mower raises the rear cutting height.

Always adjust the height adjusters to the same position both in the front and the rear for best cutting results.

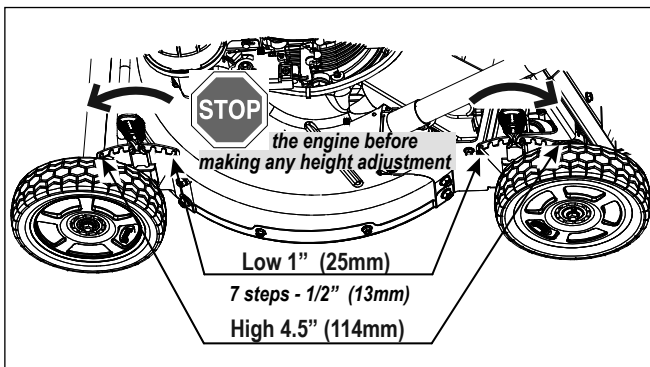

WARNING

Never readjust the cutting height while the engine is running. **STOP** the engine. Never lift the mower by placing your hand or fingers under the edge of the mower deck.

MODES OF OPERATION

This mower is approved to be used in two different operational modes:

1 With a grass catcher in place

An original equipment Bad Boy Mowers catcher has been tested to be used with this mower. It is important to always inspect the catcher for deterioration. If the material is ripped or worn the bag shall not be used.

2. With the mulch plug installed

If the mulch plug is installed ensure that the rear door can close completely.

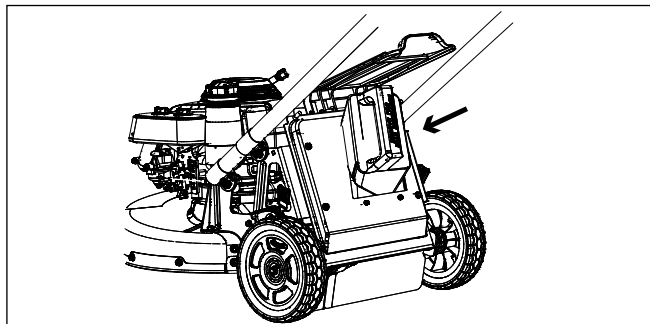

WARNING

Do not operate the lawn mower without the mulch plug or the Bad Boy Mower grass catcher in place. Never attempt to operate the mower with the rear door removed, damaged or propped open.

MAINTENANCE

Maintenance - Service Interval	Procedures
Before each use	Check the engine oil level. Check the operation and function of the Operators Presence Control bar. Inspect the mower blade for wear or damage. Inspect the cables for any wear or damage. Inspect the grass catcher for any damage. Check for any loose or missing screws or damaged parts. Clean under the lawn mower deck (after usage).
First 20 Hours or Within 4 weeks	Change the engine oil. Check the throttle cable adjustment - see Page 9.
Every 50 Hours or every 2 months	Lubricate the pivot arms on the control panel with oil. Check and Clean the engine air filter (see the engine Owner's Manual)
Every 100 Hours or every 4 months	Change the engine oil (more often in dusty conditions). Check the spark plug. Clean the engine with compressed air.
Every 200 Hours or every 8 months	Replace the paper air filter (more frequently in dusty conditions). Replace the spark plug. Adjust the valve clearance.

In addition to this schedule follow the Maintenance Schedule in the Kawasaki Owner's Manual. This maintenance schedule assumes daily use by a landscape company. One Month of use is assumed to be 15 to 20 days of operation.

NOTICE

Several of the operations described in this Maintenance section involves placing the mower on its right side.

To avoid spills of oil and gasoline always:

- Place the mower on a hard surface such as a concrete driveway or a garage floor.
- Never place the mower on its side when there is gasoline in the tank - do the service of the mower when you have run out of gasoline during normal operation.
- Always make sure that the Oil Filler Cap is tightened.

Any spillage of oil or gasoline can be extremely flammable and explosive and under certain conditions can cause serious personal injury and property damage.

CLEANING THE MOWER

We do not recommend using a garden hose to clean the mower. The buildup of moist grass, fertilizer and water can cause extreme corrosion damage to many parts of the mower and the engine.

Never use a Pressure Washer:

The use of a pressure washer can force water and moisture into ball bearings and engine parts and cause substantial damage.

- Clean the underside of the mower by scraping any build-up of grass and trash.
- Clean off the outside of the engine and the top of the mower with compressed air. Any accumulation of debris under the belt cover can typically also be removed with compressed air without removing the protective belt cover.

- Wash the Grass Bag with a garden hose frequently. The holes that allows the grass bag to breathe will eventually clog with dirt. A clogged bag will not collect the grass clippings effectively. Do not install and use a wet grass catcher. It will plug prematurely.

MAINTENANCE

BLADE MAINTENANCE

For best results, the mower blade must be kept sharp. Always replace a bent or damaged blade.

Removing the blade

1. Disconnect spark plug wire from spark plug and place wire where it cannot come in contact with plug.
 2. Turn lawn mower on its right side. (Make sure air filter and carburetor are up).
 3. Use a wood block between blade and mower deck to prevent blade from turning when removing blade bolts.
- NOTE:** Protect your hands with gloves and/or wrap the blade with a heavy cloth.
4. Remove blade bolts by turning counter-clockwise with a 11/16" (17mm) wrench or socket.

Installing the blade

1. Position the blade with the bent corner of the blade (sail) pointing towards the deck. Install the blade bolts.
- Important:** Blade bolts are heat treated. If the bolts are worn or damaged use only bolts available from Ybravo.com
 2. Use a block of wood between blade and mower deck and tighten the blade bolts. Always use a torque wrench. The recommended tightening torque is 30 to 35 ft. lbs. (40 to 45 Nm)



WARNING

Use only a replacement blade approved by Bad Boy Mowers. Using a blade not approved by Bad Boy Mowers is hazardous. It can damage your mower and cause serious personal injury.

A worn or damaged blade can break and parts of the blade could be thrown into the operators or bystanders area, resulting in serious personal injury or death.

Inspecting the blade

Carefully examine the blade for straightness, damage and abnormal wear. In some areas abrasive sand and dust can wear away the metal of the blade - see illustration.

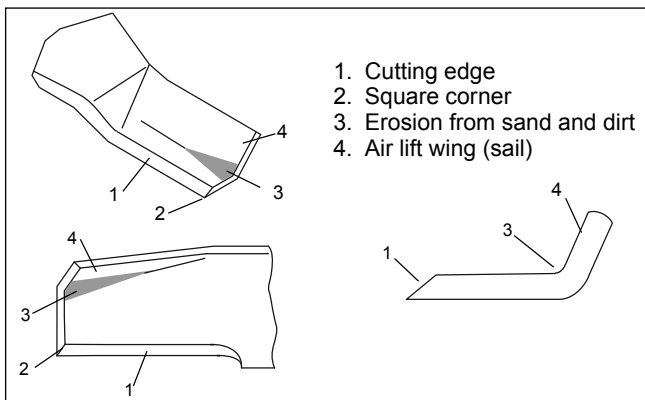

Sharpening the blade

File the top side of the blade (1) and maintain the original angle of the cutting edge. Maintain the radius where the cutting edge ends. Always remove the same amount of material from both ends of the blade. This ensures that the blade stays balanced.

If sharpening is done with a grinding stone the blade should always be balanced using a blade balancing device. A blade balance tool is available from Ybravo.com or most lawn and garden dealers, and hardware stores.

If the blade shows wear or cracking at the edge where the blade is bent up (3) it must immediately be replaced.

ENGINE OIL CHANGE

NOTICE: Before tipping lawn mower on its right side to drain oil, empty fuel tank by running engine until fuel tank is empty.

1. Disconnect spark plug wire from spark plug and place wire where it cannot come in contact with plug.
2. Remove oil filler cap/dipstick.
3. Tip lawn mower on its right side as shown and drain oil into a suitable container. Rock lawn mower back and forth to remove any oil trapped inside of engine.
4. Wipe off any spilled oil from lawn mower or side of engine.
5. Fill engine with oil. Slowly pour oil down the oil fill spout into the engine. Use an SAE 10W-30 oil (22 Fl.Oz - 0.65 Liter without oil filter, 29 Fl.Oz - 0.85 Liter with oil filter replacement). See engine Owner's Manual for complete information.
6. Wait one minute to allow oil to settle. Use the gauge on oil filler cap/dipstick for checking level. Insert dipstick into the tube and rest the oil fill cap on the tube. **DO NOT** thread the cap into the tube when taking the reading.
7. Continue adding small amounts of oil and rechecking the dipstick until it reads full. **DO NOT** overfill, or engine will smoke on startup.
8. Always be sure to retighten oil fill cap/dipstick before starting engine.
9. Reconnect spark plug wire to spark plug.

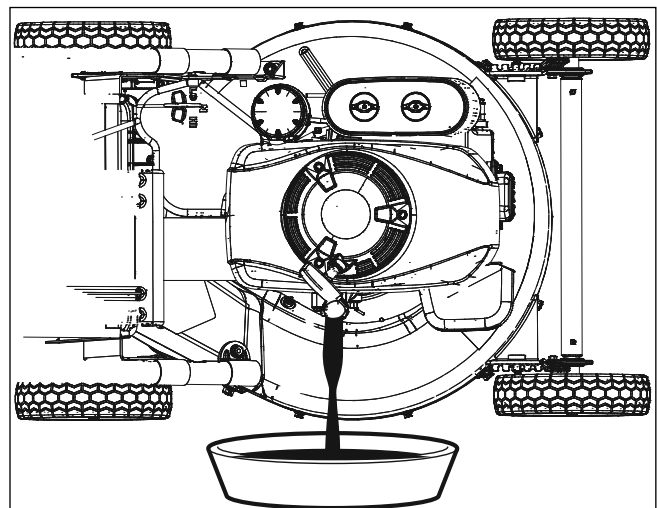



PRODUCT REGISTRATION & WARRANTY STATEMENT

All Bad Boy Push Mowers can be registered for warranty by mailing copy of the warranty registration in this manual with a copy of the sales invoice/receipt to: **Bad Boy Inc, Attention: Warranty Department, 102 Industrial Dr, Batesville, AR 72501.**

SECTION 1: LIMITED WARRANTY

Bad Boy Mowers Inc (BBM) warrants the original purchaser of a BBM branded push mowers product to which this warranty applies (the "Product") that the Product shall be free from defects in material and workmanship from the date of purchase for the period of the applicable "Warranty Schedule" of the Product as set forth below. Additional limitations are described in Section 2 through Section 6, inclusive.

Product Category	Standard Warranty	Rental Warranty
BB21 Zone Start Mower	1 Year	No Warranty
Replacement Parts (Excludes components which are part of engine systems manufactured by third party engine manufacturers for which the purchaser has received a separate warranty with product at time of purchase.)	60 Days	No Warranty

SECTION 2: BAD BOY MOWERS' OBLIGATIONS UNDER THE WARRANTY

BBM will repair or replace defective components without charge for parts or labor if a component fails because of a defect in material or workmanship during the warranty period.

SECTION 3: ITEMS NOT COVERED BY THIS WARRANTY

The following items are not covered by this warranty:

- 1) Normal customer maintenance items which become worn through normal regular use, including, but not limited to, belts, blades, blade adapters, cables, clutches, clutch drums, filters (fuel line, fuel filters, air filters, oil filters), lubricants, rewind springs, spark plugs, and starter ropes.
- 2) Natural discoloration of material due to ultraviolet light;
- 3) Engine and drive systems not manufactured by BBM; these items are covered by the respective manufacturer's warranty as provided in writing with the product information supplied at the time of purchase; all claims must be sent to the appropriate manufacturer.
- 4) Commercial mowing decks with sand abrasion damage.
- 5) Emission Control System components necessary to comply with CARB-TIER II and EPA regulations which are manufactured by third party engine manufacturer.

SECTION 4: EXCEPTIONS AND LIMITATIONS

This warranty shall be inapplicable to defects resulting from the following:

- 1) Accident, abuse, misuse, negligence and neglect, including stale fuel, dirt, abrasives, moisture, rust, corrosion, or any adverse reaction due to incorrect storage or use habits;
- 2) Failure to operate or maintain the unit in accordance with the Owner's/Operator's manual or instruction sheet furnished by BBM;
- 3) Alterations or modifications that change the intended use of the product or affects the product's performance, operation, safety, or durability, or causes the product to fail to comply with any applicable laws; or
- 4) Additional damage to parts or components due to continued use occurring after any of the above.

REPAIR OR REPLACEMENT AS PROVIDED UNDER THIS WARRANTY IS THE EXCLUSIVE REMEDY OF THE PURCHASER. BBM SHALL NOT BE LIABLE FOR ANY INCIDENTAL OR CONSEQUENTIAL DAMAGES FOR BREACH OF ANY EXPRESS OR IMPLIED WARRANTY ON THESE PRODUCTS EXCEPT TO THE EXTENT PROHIBITED BY APPLICABLE LAW. ANY IMPLIED WARRANTY OF MERCHANTABILITY OR FITNESS FOR A PARTICULAR PURPOSE ON THESE PRODUCTS IS LIMITED IN DURATION TO THE WARRANTY PERIOD AS DEFINED IN THE LIMITED WARRANTY STATEMENT. BBM RESERVES THE RIGHT TO CHANGE OR IMPROVE THE DESIGN OF THE PRODUCT WITHOUT NOTICE, AND DOES NOT ASSUME OBLIGATION TO UPDATE PREVIOUSLY MANUFACTURED PRODUCTS.

Some states do not allow the exclusion of incidental or consequential damages, or limitations on how long an implied warranty lasts, so the above limitations or exclusions may not apply to you. This warranty gives you specific legal rights, and you may also have other rights which vary by state.

SECTION 5: CUSTOMER RESPONSIBILITIES

The product must exhibit reasonable care, maintenance, operation, storage and general upkeep as written in the maintenance section of the Owner's/Operator's manual. Should an operational problem or failure occur, the product should not be used. Failure caused by continued use is not covered by warranty. Product should be delivered, at owners' expense, as is, to an authorized BBM Dealer for evaluation. Proof of purchase, as explained in section 6, rests solely with the customer.

SECTION 6: PROCEDURE TO OBTAIN WARRANTY CONSIDERATION

It is the Owner's and Dealer's responsibility to make certain that the Product Registration was completed and mailed to BBM. Product Registration should be completed within ten (10) days from the date of purchase in order to confirm the warranty and to facilitate post-sale service. Proof of purchase must be presented to the authorized BBM dealer in order to obtain warranty service. This proof must include date purchased, model number, serial number, and complete name and address of the selling dealer. To obtain the benefit of this warranty, the product believed to be defective must be delivered to an authorized BBM dealer in a timely manner, no later than thirty (30) days from date of the operational problem or failure. The product must be delivered at the owner's expense. Downtime, pick-up and delivery charges are not covered by this warranty. An authorized BBM dealer can be located by calling (866) 622-3269. Subject to change without notice.

